



**GROUSER[®]
PRODUCTS**

755 2nd Ave NW
West Fargo, ND 58078
701-282-7710 / 800-747-6182
www.grouser.com

FH Hard Track & EX Hard or Soft Track[®] Mounting Instructions



FH Hard Track



EX Hard Track



EX Soft Track

Date of Purchase

Machine

Track Model Number

Purchased from

Phone Number

FH & EX Combo Track Mounting Instructions

General Information

Read all instructions before beginning installation of tracks



CAUTION: To avoid injury, always raise skid steer boom arms , lower onto boom locks and set parking brake before mounting or dismounting tracks

- Follow precautions in skid steer operators manual when performing any work on skid steer.
- Always wear proper safety gear
- Stop engine when its operation is not necessary for track installation process.
- Any modification to the loader that may be necessary is the responsibility of the owner.

Note: For ease of installation, take one pad and use it to check for clearance before you begin mounting the tracks.

1 :CHECK TRACK PAD TO TIRE FIT

- The track pad should fit the tire with some side to side clearance.
 - A pad that squeezes the tire will cause premature side wall wear.
 - Tire pressure should be as recommended by the tire manufacturer. Not following this recommendation could result in premature tire failure.
 - Although tracks have been sized to standard Skid Steer tire sizes, it is possible for tires to vary up to 1" (25 mm) in diameter and width.
 - Tires can vary in width due to different width rims and tire profiles.
 - If the track squeezes the tire, contact Grouser Products.
- Tire Tread design is also important to track performance.
 - Tracks were designed to grip the tire by having the tire tread bars squeeze between the track traction bars. If a tire does not have an open bar design or is worn to the point that the tire face is essentially smooth, the tires will easily spin inside the tracks and not perform as designed.

Notes:

- Track can be taken apart and put together at any pad. All pads and links are the same.
- Air Boss, Aircraft, Solid Rubber, and Foam—Filled tires should not be used in combination with tracks. Failures associated with non-pneumatic tire and track combinations are not covered by warranty.
- Please read all instructions before beginning installation of tracks.
- Tracks were designed to run loose, not tight. Each set of tracks was assembled in the long position and therefore may need to be adjusted for your application

DETERMINING PROPER CLEARANCE BETWEEN TRACKS AND SKID STEER

- Check around skid steer frame and tires for adequate space for track installation. The skid steer will require approximately 1.5" (38 mm) of clearance around the face of the tire and about 2.5" (63.5 mm) at the side of the tire to be able to accommodate tracks.
- Tire clearances play a very important part in proper track installation. Even though tracks have been designed to take up as little room as possible, there will be skid steers that have interference areas such as fenders, gussets, boom arms, hoses, hubs, etc. Oversize diameter tires, narrow tires, and wide tires can also cause interference. It may be necessary to change tires to correct an interference problem.
- After the tracks have been installed, verify that you have a minimum 0.5" (13 mm) of clearance around the face of the track and 0.75" (19 mm) of clearance from the inside side plate of the track to the machine. (Side to side movement on the tire is acceptable as long as it does not allow tracks to come in contact with the skid steer frame or lift arms .)
- A full set of tracks is shipped in one roll and must first be split in the middle which are connected with wire.

Track Shipment Includes:

- (A) Track Includes Links, Bushings, Nuts And Bolts
- (B) Web Binder
- (C) Binder Brackets
- (D) Product Information and Instructions

If needed and ordered

- (E) Wheel Spacer Kit
- Boom Stop Kit (Not Shown)

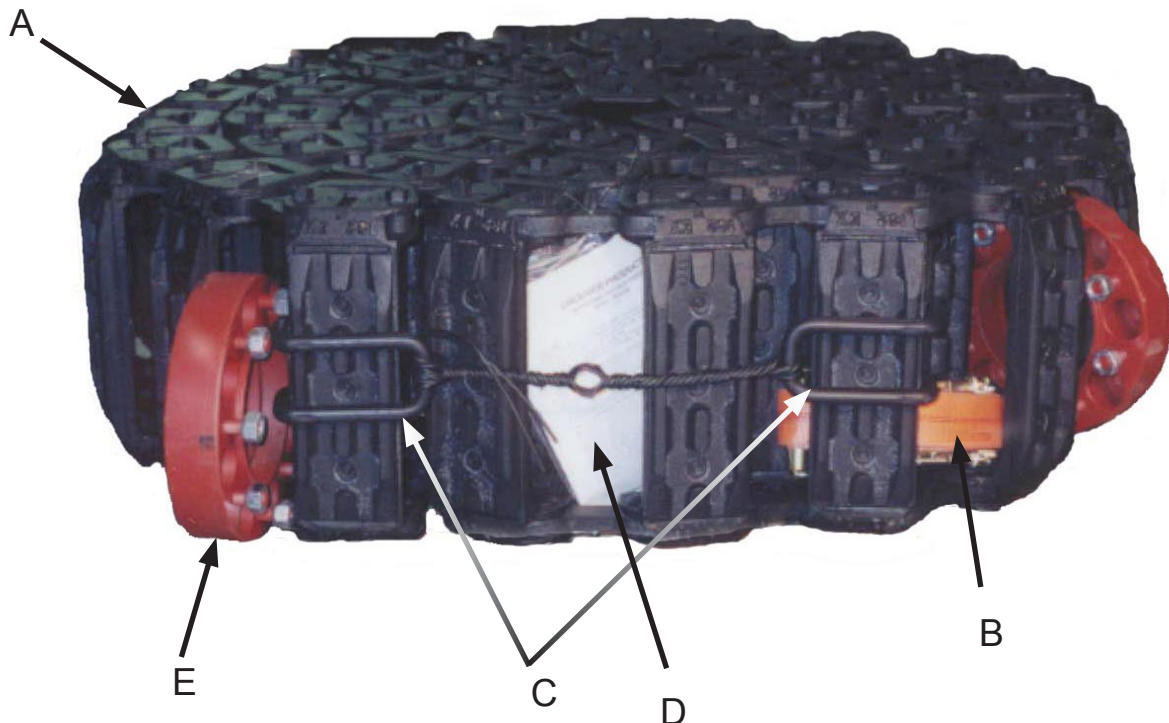

Installing Track With Operator Only



1: Position track face up on a level surface, roll first pad onto the adjacent pad. Drive skid steer up to track. Tie a rope around the center of first pad.



2: Center rope over front tire and pull rope towards back tire.



3: Tuck end of rope under rear tire.



4: Drive skid steer backwards to pull the track onto the front tire.



5: Continue to backup, the rope will carry the track from the front tire to the rear tire.



6: The track will roll around the rear tire and start towards the front.

Installing Track With Operator Only Continued



7: Stop the skid steer when the two ends of the track are at the front of the machine.



8: Tie the two ends of the track together with the rope.

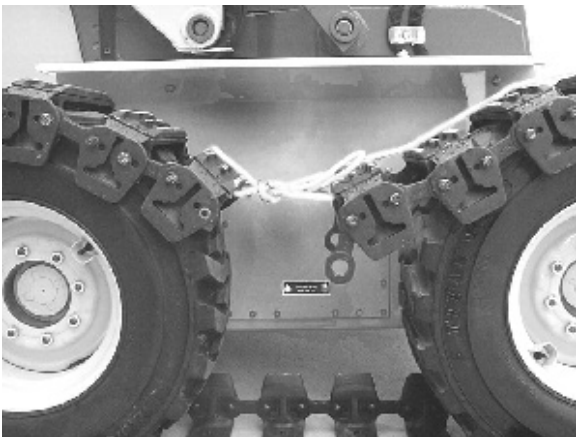

9: Drive the skid steer backwards to position both ends of the track between the tires of the skid steer.

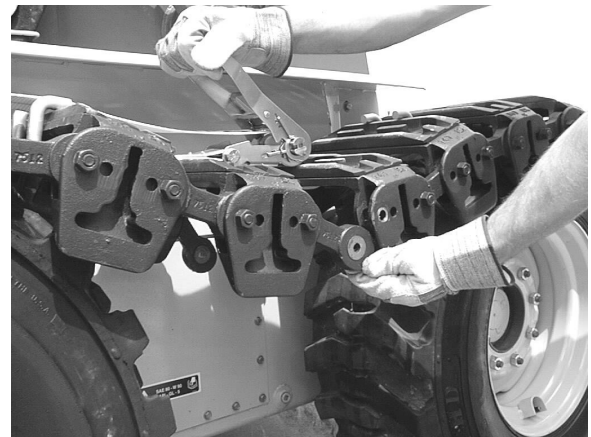

10: Untie the rope and continue with installing the binder bracket and ratchet strap.

To complete installation see page 7. For two man installation see page 6.

Installing Track With Operator And Helper



1: Lay track face down on a level surface. Drive skid steer forward onto track.



2: Drive until track is just past the rear tire



3: Have helper pickup pad section and hold it against rear tire, drive skid steer forward and the track will follow the tire around.



4: As the track comes between the tires, lift the pad section across to the front tire.



5: When both ends of the track are at the front of the machine hold pad section against front tire, back skid steer up and track will follow tire.



6: Stop skid steer when both ends of track are between tires and continue with installing the binder bracket and ratchet strap.

(Continue on page 7)

How To Install Binder Brackets & Ratchet Strap

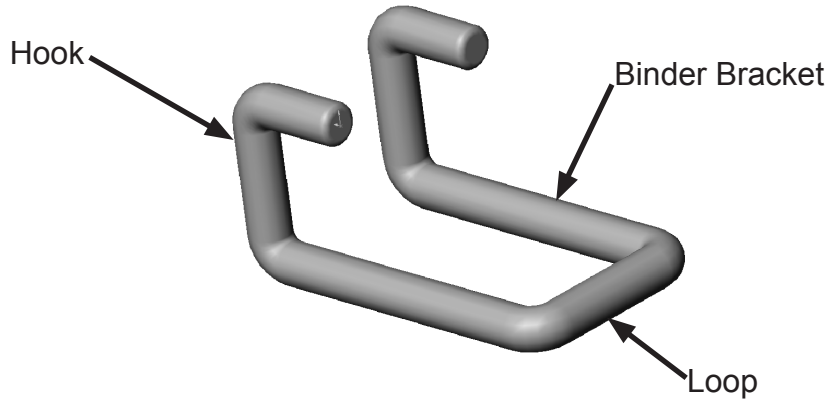

Binder bracket must be installed with loop side between track pad and tire.

Install binder brackets (2) on second pad from each end, center brackets between links.

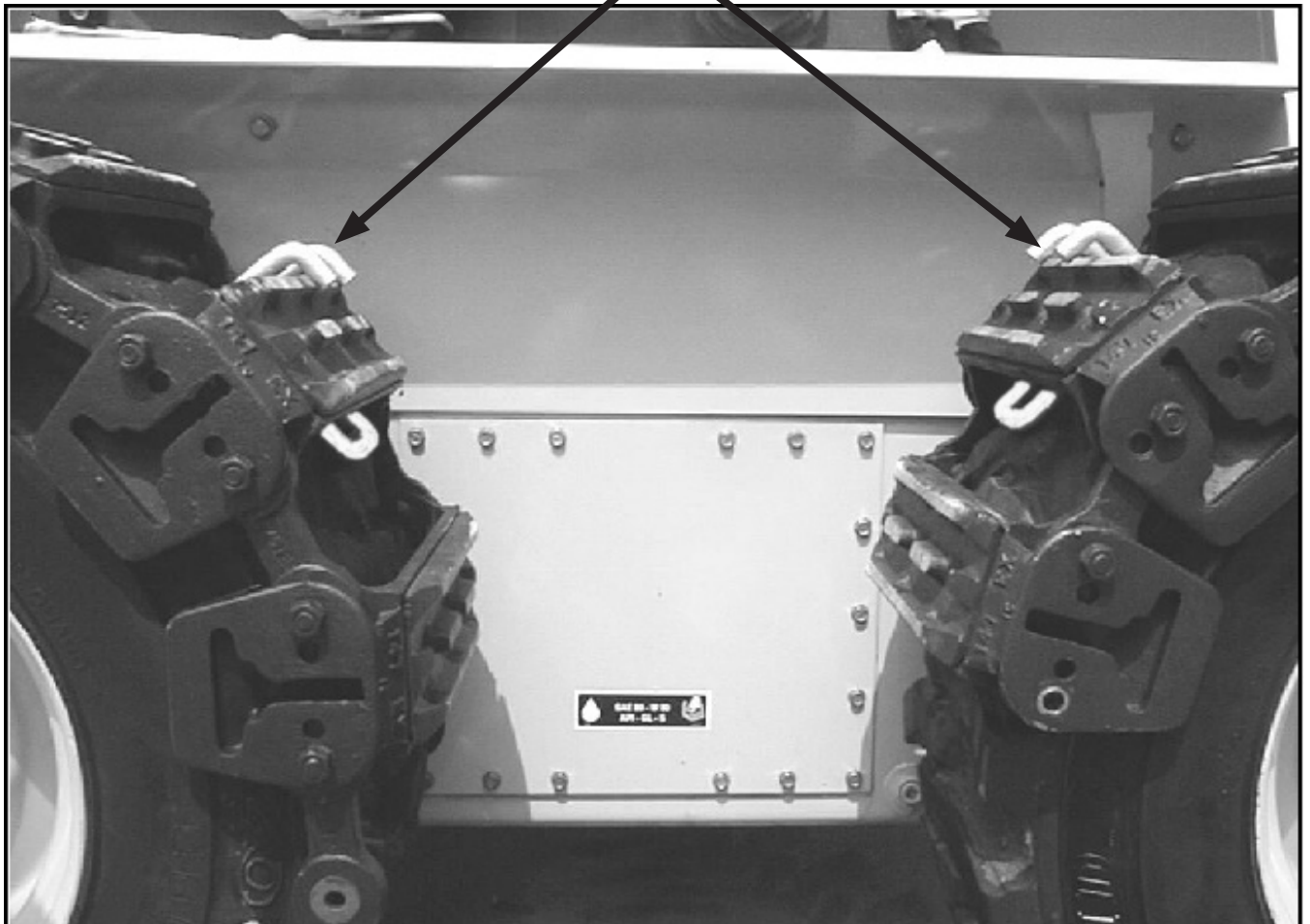

Installing Binder Bracket And Web Binder Continued

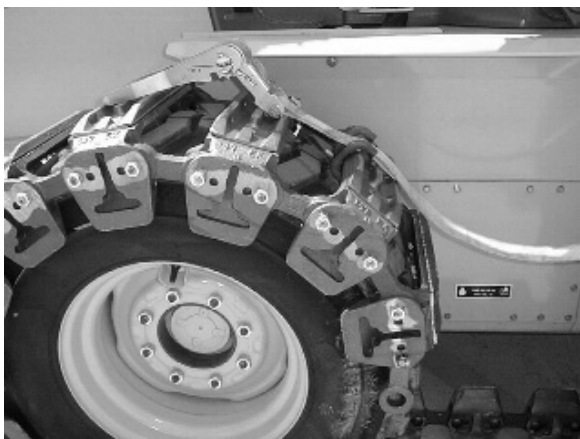

1: Stand facing skid steer. Place web binder on left hand track / tire as shown.



2: Thread strap through loop in binder bracket and under first pad from left end.



3: Pull strap across to right end of track, run strap under first pad of right end and through loop in binder bracket.

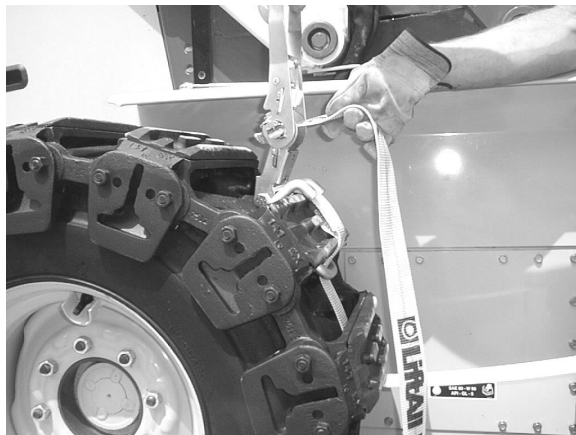

4: Slide end of strap through slot at center of ratchet assembly. Make sure there are not twists in strap.

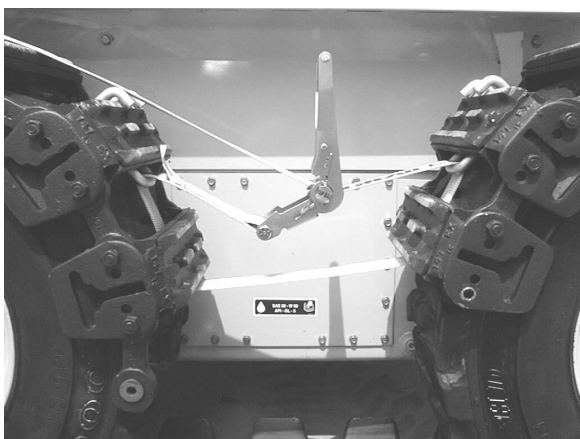

5: When strap is routed correctly it will look like this. Note that having the strap under the last pad on each end will assist in holding the pads up.

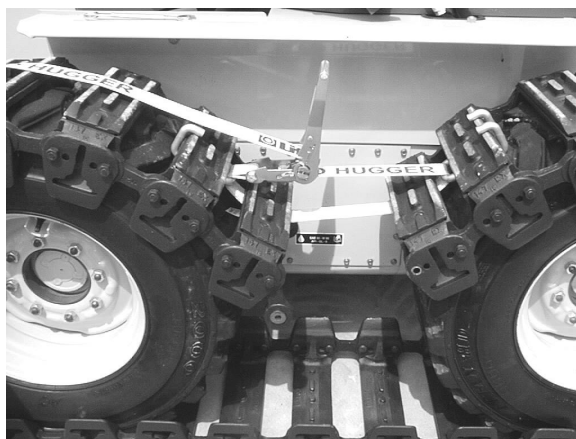

6: Slide strap assembly as far to the left as possible. With one hand pull out slack in strap while using other hand to ratchet the handle. Continue to ratchet slack is taken out of track.

Installing Binder Bracket And Web Binder Continued

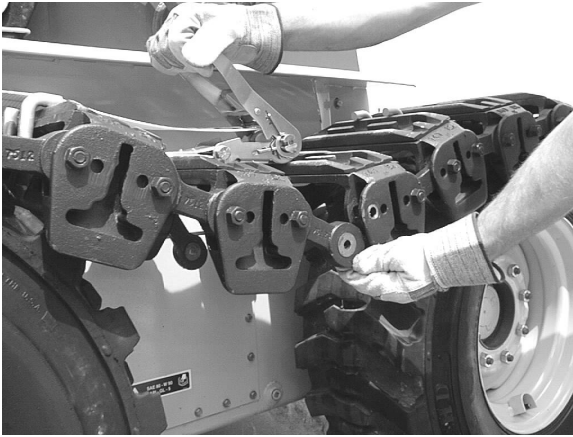

7: Continue to ratchet until the links will go into the slots on the adjoining pad. Make sure the bushings are installed in the links.

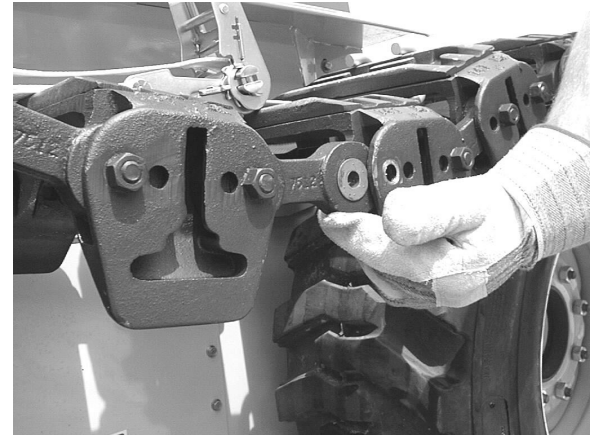

8: Both links need to be in the slots at the same time. Run ratchet handle until the bolt holes in the pad line up with the holes in the bushing.



9: The skid steer will have to be driven back and forth to ensure a majority of the slack is taken out. Be careful not to drive too far, as damage to web binder or skid steer might occur.

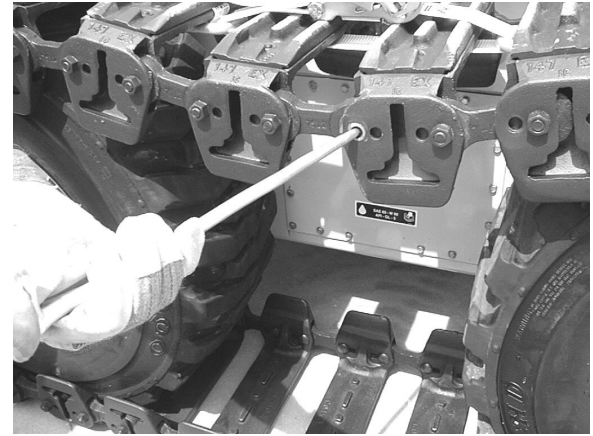

10: If the holes don't line up correctly a line-up punch can be used.

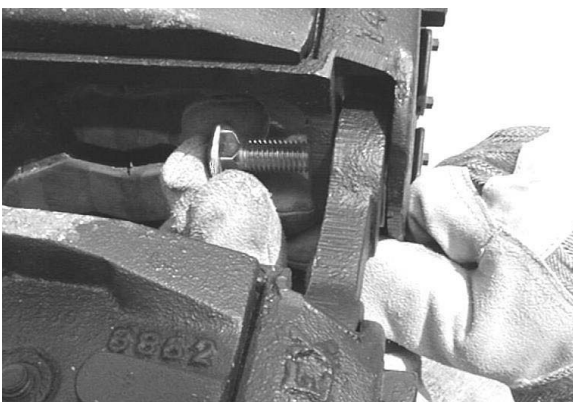

11: Insert bolts from inside of track. Put lock-nut on outside of track. Once both bolts are inserted, web binder and brackets may be removed.



12: To ease in tightening bolts, move machine so bolts are at an accessible area. Torque bolts to 100-105 Ft. Lbs. Repeat for other side of skid steer.



IMPORTANT: If track is adjusted too tightly, damage is likely to occur to the tracks and skid steer.

Pull the ends together and install the pair of bolts in the long or short hole spacing as needed.

(A) - Use for long spacing of tracks.

(B) - Use for short spacing of tracks.

(C) - Do not shorten pads on both ends of a link.

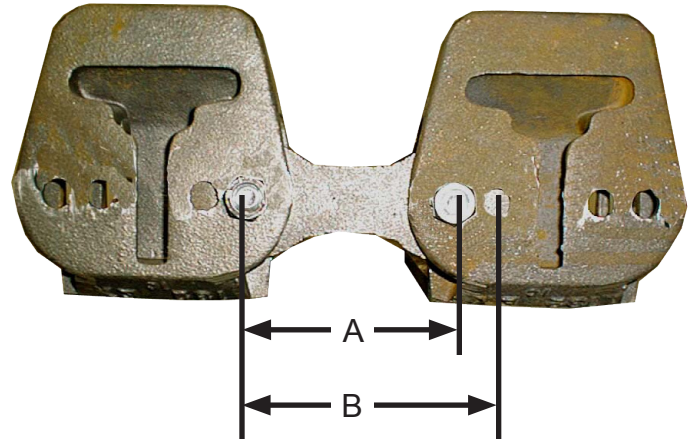

The proper track length is achieved when all the slack in the tracks is at the top and there is approximately 1" to 3" (25 mm to 76 mm) of sag between the straight edge (D) placed over the top of the tires, and the pad (E) pad that is centered between the tires. (Refer to Figure 9)

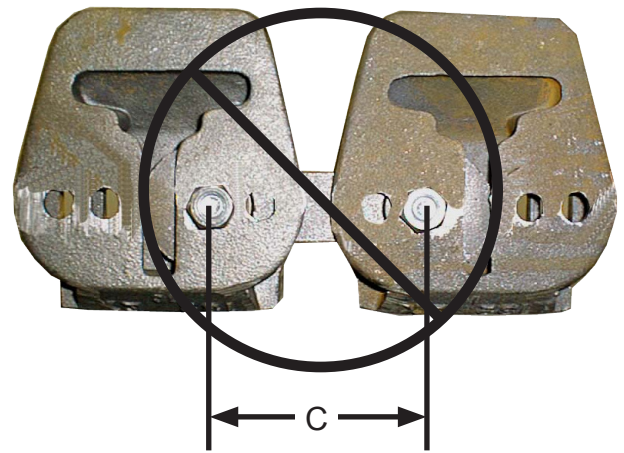

A quick and easy way to determine how much the track may have to be adjusted is to remove one pad section (which is equal to 7.125 inches) pull the end together with the binder. Measure the amount needed to connect the track and subtract the amount from 7.125 inches. Divide the difference by .81, or look up the answer in the chart below and the answer is the number of bolts you should move to the short holes.

Adjusting 9 bolts to the short position is equal to removing 1 pad section. If the track is still too long, use the binder to position the link bolts in the short holes until the proper track length is obtained.

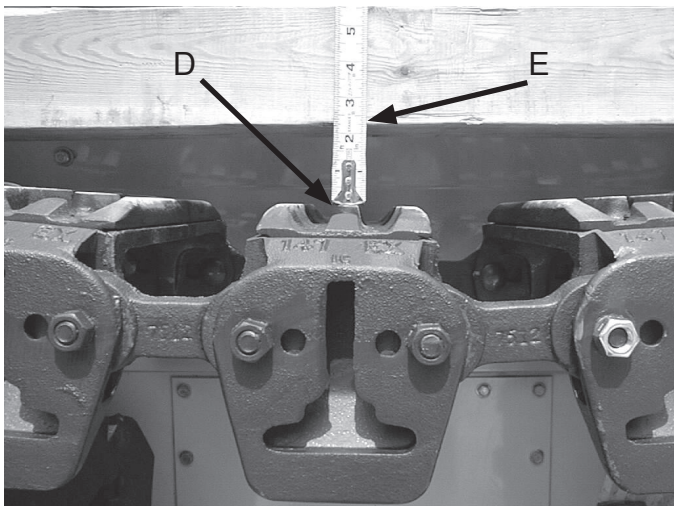

Note 1: If it appears that you will need to adjust more than a few pairs of bolts in order for the track to fit, it is easiest if you drive the skid steer off the track and adjust the track on the ground.

Note 2: Adjustment of track length may vary on each side of the skid steer due to variations in the tire diameters.

REMOVING TRACKS

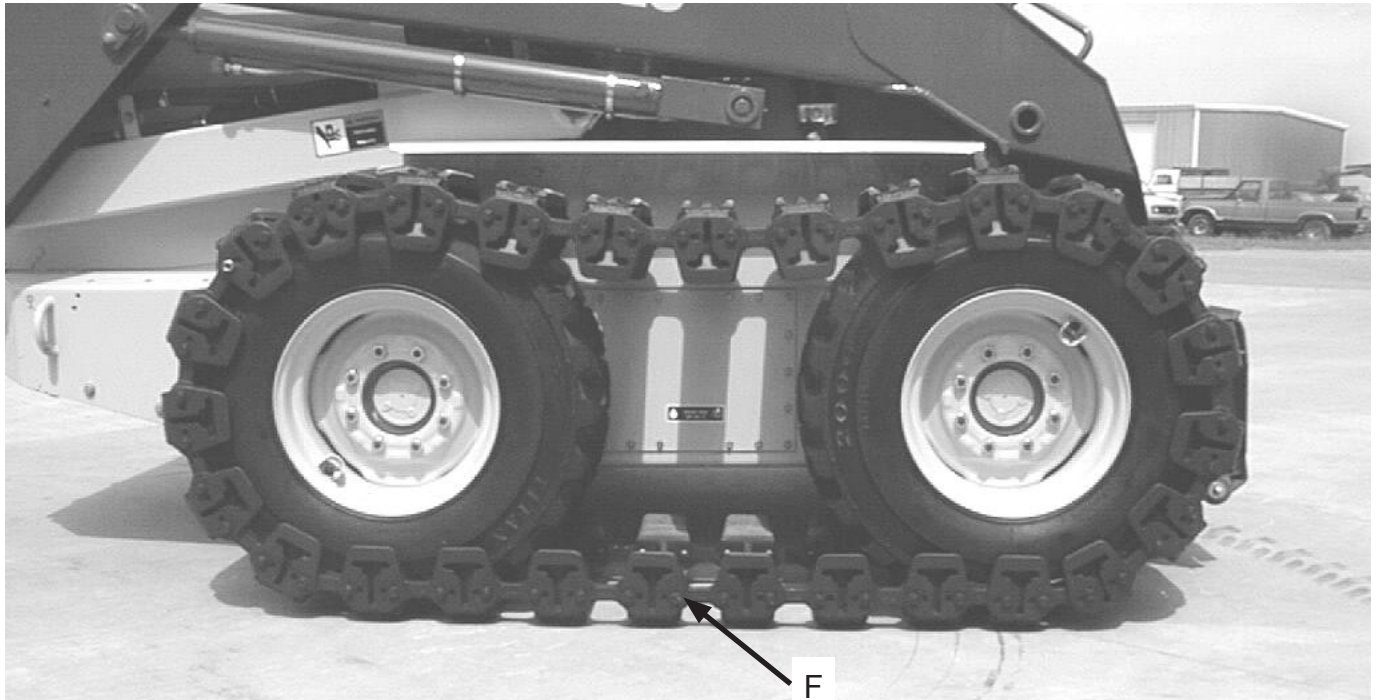

Tracks are easily removed by taking the bolts out from between the tires on the bottom of the track (F). Once the bolts are removed, simply drive out from the tracks. Install the removed bolts back into the last pad to avoid losing or damaging them.

Note 1: If tracks are going to be stored in the laid out position, move the skid steer to the storage area.

Note 2: If tracks are going to be rolled up and stored on a pallet, it is best to remove them on a hard surface. The easiest way to roll the tracks is to set them on edge.

Testing The Track

With both sides installed, drive the loader slowly in both directions to ensure that the track does not come in contact with any part of the loader. If there is contact, proper modifications must be made which is the responsibility of the owner. Test the loader until it can be driven at top speed in any condition without the tracks hitting. In the first few days of use check the track frequently to see that all bolts are staying tight and that no damage is being caused to the tires or machine. If you are in doubt about anything regarding the running or use of the track, please contact Grouser Products.



Remember



1. Proper tire air pressure is essential to track performance. Too low of tire air pressure will result in excessive tire side wall wear, or cause the bead of the tire to break.
2. Tracks that are too loose will result in excessive tire tread wear.
3. Excessive spinning of the tires inside the tracks can and will cause damage to the tires.
4. Foreign objects between the track and the tire will cause the track to become excessively tight which could lead to axle bearing failure.
5. When adjusting the tracks always re-torque bolts to 100-105 Ft. Lbs.
6. When replacing hard or soft shoes, torque 1/2" bolt to 80 Ft. Lbs.
7. Keeping the binder and brackets in the loader, in the event of a flat tire, will assure speedy track removal and reinstallation.
8. With proper maintenance and care your Grouser track system will provide you with countless hours of productive service.

FH Hard Track Parts List

Description	Model #	Total Quantity Needed Per Set Of Tracks									
		32	34	36	38	40	42	44	46	48	50
Pad	132FH	32	34	36	38	40	42	44	46	48	50
Pad	147FH	32	34	36	38	40	42	44	46	48	50
Nut, Hex 1/2"	8865	128	136	144	152	160	168	176	184	192	200
Bolt, Carriage	8866	128	136	144	152	160	168	176	184	192	200
Bushing	8864	128	136	144	152	160	168	176	184	192	200
Link	3959	64	68	72	76	80	84	88	92	96	100
Binder Brackets	4824	2	2	2	2	2	2	2	2	2	2
Web Binder	1586	1	1	1	1	1	1	1	1	1	1

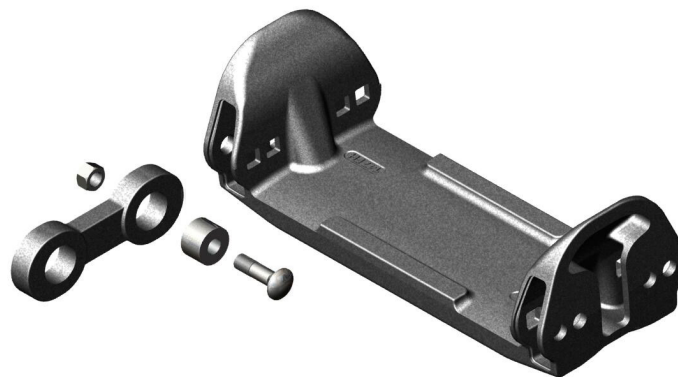

EX Hard and Soft Track Parts List

Description	Model #	Total Quantity Needed Per Set Of Tracks											
		32	34	36	38	40	42	44	46	48	50	52	54
Pad	132EX	32	34	36	38	40	42	44	46	48	50	52	54
Pad	147EX	32	34	36	38	40	42	44	46	48	50	52	54
Nut, Hex 1/2"	8865	128	136	144	152	160	168	176	184	192	200	208	216
Bolt, Carriage	8866	128	136	144	152	160	168	176	184	192	200	208	216
Bushing	8864	128	136	144	152	160	168	176	184	192	200	208	216
Link	7512	64	68	72	76	80	84	88	92	96	100	104	108
Traction Bar - 132EX	132LTB	32	34	36	38	40	42	44	46	48	50	52	54
Traction Bar - 147EX	147LTB	32	34	36	38	40	42	44	46	48	50	52	54
Hard Insert - 132EX	1883	32	34	36	38	40	42	44	46	48	50	52	54
Soft Insert - 132EX	7752	32	34	36	38	40	42	44	46	48	50	52	54
Hard Insert - 147EX	1884	32	34	36	38	40	42	44	46	48	50	52	54
Soft Insert - 147EX	8061	32	34	36	38	40	42	44	46	48	50	52	54
Binder Brackets	4824	2	2	2	2	2	2	2	2	2	2	2	2
Web Binder	1586	1	1	1	1	1	1	1	1	1	1	1	1

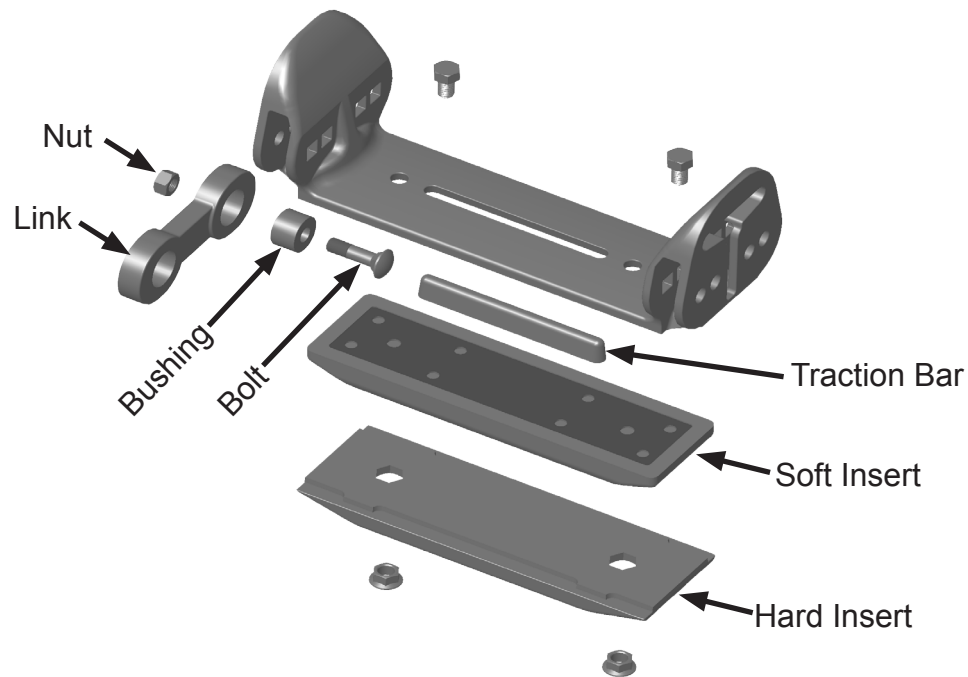

WARRANTY: Grouser Products, Inc. warrants its Tracks for two years against defective material or workmanship. The warranty is for repair or replacement of those parts that are defective. Any modification to the Track parts without proper authorization voids the warranty. Any product returned to Grouser Products for warranty inspection must be shipped prepaid and will be returned freight collect unless authorized otherwise. All costs for removal and installation are at customer's expense. Grouser Products Warranty does not cover damages to loader, loader tires or environment resulting from use. Tire sizes can and do vary in width and height, which can cause tire damage or a clearance problem. It is the responsibility of the customer to determine that final fit including clearances and safety shielding is correct. If you have any questions pertaining to this warranty please call Grouser Products at 800-747-6182. There is no other warranty.

Soft And Hard Shoe Installation Instructions

Caution:

Always use precaution when working around any equipment.

Always wear safety glasses.

Follow skid steer manufacture's safety guidelines when installing this product.

Read all instructions prior to performing installation.

Remove any foreign objects (mud, dirt, or rust) from the recessed shoe cavity on the cast pad to ensure a good, tight fit of the shoe.

Seat traction bar in slot of pad. When installing used traction bars, check for extensive wear and order new bars if needed.

a. For soft shoe, start two $\frac{1}{2}$ " x $\frac{3}{4}$ " bolts into tapped holes of soft shoe.

b. For hard shoe, start two $\frac{1}{2}$ " x 1" bolts through holes of hard shoe and into two $\frac{1}{2}$ "

flange nuts.

Torque all $\frac{1}{2}$ " bolts to 80 ft-lbs

After first 10 hours of operation, inspect and re-torque all bolts.

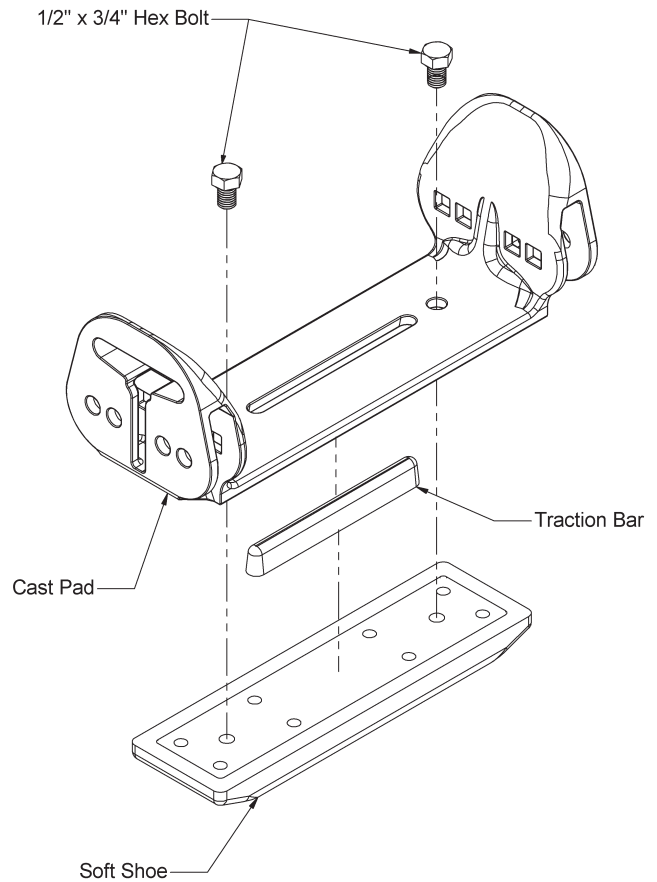
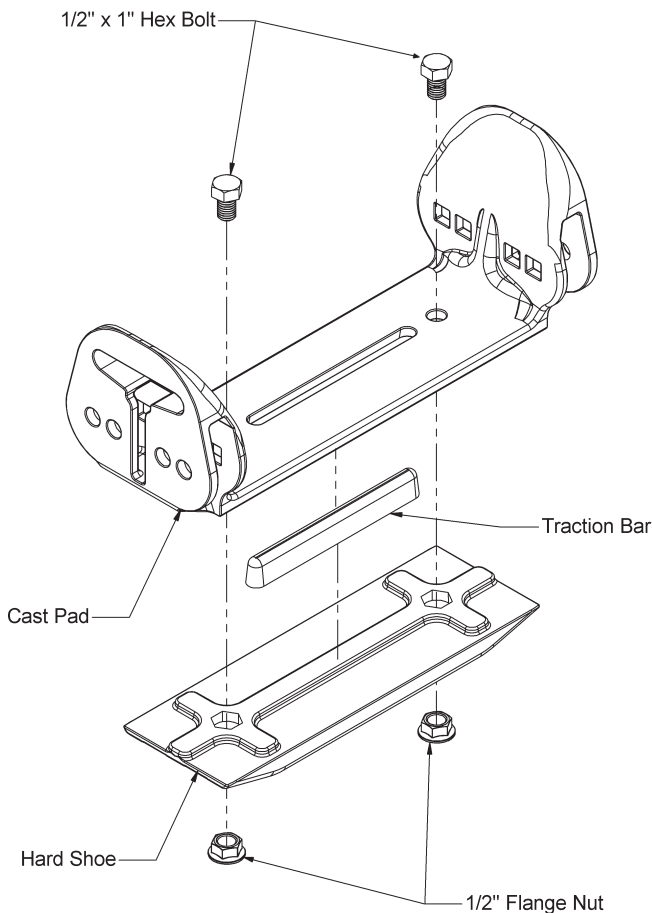

Installing Wheel Spacers (if required)

1. TURN THE WHEELS AROUND IF RIM HAS ADEQUATE OFFSET See Diagram (below)

Note: Bolt holes should be countersunk on both sides of the rim to reverse the wheels. If only one side is countersunk the rim can still be turned around if the contact to the axle is sufficient and the rim center hole sits on the axle pilot. The nuts should be turned around so the flat side will contact the rim. A flange nut or flat washer can be used if necessary.

Any questions on this method please call Grouser at 800-747-6182.

- Remove right front wheel and replace with left front wheel making sure the tread is still facing forward.
- Place right front wheel on left front of skid steer with tread facing forward.
- Repeat for rear tires.
- Torque wheel nuts to factory recommended specs.
- Check nuts frequently to ensure they remain tight.

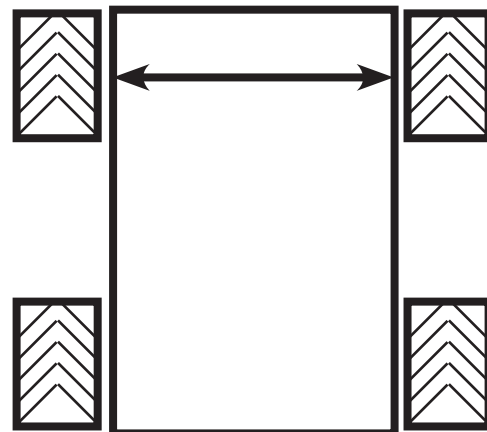

2. INSTALL WHEEL SPACERS: See Diagram (below)

- Remove loader wheel.
- Sand and clean the face of the axle flange and the rear of the spacer to bare metal.
- Bolt the spacer to the loader axle using the loader wheel nuts.
 - Torque wheel nuts to factory recommended specs. (See Loader Service manual)
 - Lock tight may be used to ensure these nuts stay tight.

Note: Once the wheel is mounted, the axle hub nuts are not accessible

- Clean mounting surface, then mount the rim on the spacer studs with provided spacer nuts.
- Install wheel nuts and spacer nuts in the manufacturers suggested start pattern.
- Torque spacer nuts to specifications shown in Table 1 or factory recommended specifications whichever is more.
- Check nuts frequently to ensure they remain tight.
- If your machine requires you to turn the wheels around and install wheel spacers, please see your Track installation manual for instructions for turning the wheels around.

Although Grouser has made recommendations on clearance requirements and suggested modifications, it is the sole responsibility of the owner to determine and correct any clearance problems that may exist. Grouser does not warrant or take responsibility for any damage that may incur from modifications made to the loader so "Over-the-tire" tracks can be used.

Table 1

Wheel Nut Torque Specification	
	FT/Lbs.
9/16"	120-140
5/8"	140-160
16mm - 1.5 Pitch	190
16mm - 2.0 Pitch	190

