



Fendt 900 Series 2

Undercarriage Installation Instructions

Caution:

- Always use precaution when working around any equipment.
- Always wear safety glasses.
- Follow tractor manufacturer's safety guidelines when installing this product.
 1. Read all instructions prior to installation.
 2. Position the undercarriage (U/C) under the tractor with the front ears towards the front of the tractor and center with the frame of the tractor.
 3. Support the front linkage frame and remove the pins that hold the frame to the tractor.
 4. Lift the front of the U/C.
 5. Once the ears are aligned with the ears on the tractor frame and the front linkage frame, insert a pin (PN: 43-13882) on each side.
 6. Once the pins are in place, insert a spacer (PN: 19-13515) in the open space between the legs of the pin heads. Insert a 3/4" bolt (PN: 16-20219) with a 3/4" flat washer (PN: 57-20747) through each spacer and the hole on the U/C. See attached diagram for any clarification.
 7. After the bolts are in, install a 3/4" nut (PN: 70-20607) on each bolt.
 8. Block the ends of the tank support.
 9. Remove the 16mm bolts from the tractor frame where the rear of the U/C will be installed.
- 10. Remove the small bolts that are in between the 16mm bolts.
- 11. Install the 1" nuts (PN: 70-20589) and the 1" bolts (PN: 16-20562) as shown in the attached drawing.
- 12. Tape the push plate to the undercarriage so the 1" bolts are touching the plate. See the attached drawing for the correction location.
- 13. Lift the rear end of the U/C.
- 14. Install 4 - 16mm bolts (PN: 16-16200100) and 4 - 5/8" flat washers (PN: 57-20816) in the holes of the rear plate on the U/C. Finger tighten only.
- 15. Tighten the 1" bolts to push the push plate up tight against the tractor casting. Torque the 1" bolts to 90-95 ft-lbs.
- 16. Tighten the nuts up tight against the back plate on the U/C. Use the nuts to lock the bolts in place.
- 17. Torque the 16mm bolts to 200 ft-lbs.
- 18. After the first 8 hours of use, re-torque all bolts.
- 19. Check all fasteners regularly to ensure proper operation of equipment.

THE INFORMATION CONTAINED IN THIS DRAWING IS THE SOLE PROPERTY OF GROUSER PRODUCTS INC ANY REPRODUCTION IN PART OR WHOLE WITHOUT THE WRITTEN PERMISSION OF GROUSER PRODUCTS INC IS PROHIBITED.

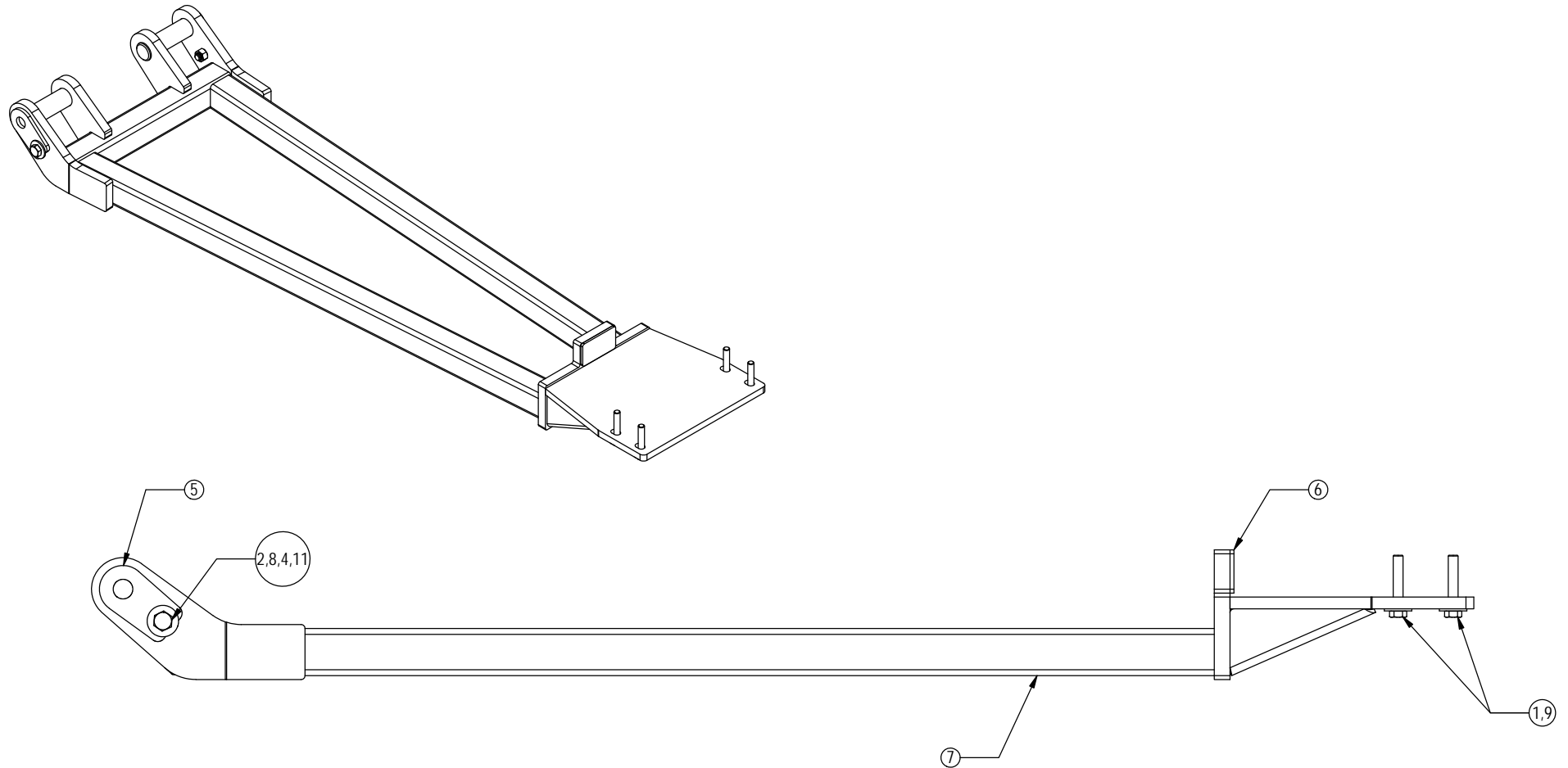

Item No.	Qty.	Part No.	Description
1	4	16-16200100	16mm x 2.00mm x 100mm Metric Hex Bolt Gr 10.9
2	2	16-20219	3/4" x 2-1/4" Hex Bolt Gr 5 NC
3	2	16-20562	1" x 3" Hex Bolt Gr 5 NC
4	2	19-13515	3/4" ID - Non Rotating Pin Spacer Bushing
5	2	43-13882	Fendt 900 (Series 2) Pin
6	1	44-13872	Fendt (Series 2) Push Plate
7	1	54-13880	Fendt 900 (Series 2) Undercarriage
8	2	57-20747	3/4" Flat Washer
9	4	57-20816	5/8" Flat Washer Grade 8 (USS)
10	2	70-20589	1" Hex Nut
11	2	70-20607	3/4" Hex Center Lock Nut



GROUSER PRODUCTS INC.

755 2nd Ave NW Phone 701.282.7710
 West Fargo, ND 58078 Fax 701.282.8131
 WWW.GROUSER.COM

TITLE: Fendt 900 (Series 2) UC

Date: 5/14/2009

DWG. NO.: 13880-A