



FH-400 Versatile 250-305 Ultrasteer Series

Undercarriage Installation Instructions

Caution:

- Always use precaution when working around any equipment.
- Always wear safety glasses.
- Follow tractor manufacturer's safety guidelines when installing this product.
 1. Read all instructions prior to installation.
 2. Remove weights and weight bracket from front of tractor if necessary.
 3. Use long 1" bolts in the axle where the weight bracket bolts were removed. Use the original washers and nuts if available. If not available, use 1" I.D. x 2.50" O.D. washers (PN: 57-8835) with 1" nut (PN: 70-20599) on the top bolts, and use 1" flat washers (PN: 57-20759) with the bottom bolts. Torque the 1" bolts to the tractor manufacturer's specifications.
 4. Position the undercarriage (U/C) in front of axle and center with the frame of the tractor.
 5. Loosely attach the left and right rails (PN: 44-14063-R,L) to the U/C with 3 - 1" x 2" bolts (PN: 16-20558), 6 - 1" heavy flat washers (PN: 57-20819), and 3 - 1" nuts (PN: 70-20599) on each side.
 6. Lift the U/C until the front holes on the tractor line up with the front holes on the U/C.
 7. Start 2 - 20mm x 70mm bolts (PN: 16-1876) with a 3/4" flat washer (PN: 57-20747) on each bolt through the top inside holes of the U/C into the front holes of the tractor. See attached diagram for any clarification.
 8. Start 4 - 20mm x 90mm bolts (PN: 16-1510) with a 3/4" flat washer (PN: 57-20747) on each bolt through the remaining holes of the U/C into the front holes of the tractor. Also use a 3/4" flat washer as a spacer between the undercarriage and tractor frame. See attached diagram for any clarification.
 9. Attach each side rail to the tractor frame with 4 - 3/4" x 3" bolts (PN: 16-20222), 4 - 3/4" flat washers (PN: 57-20747) on the outside, and 4 - 3/4" nuts (PN: 70-20607) in the top holes.
 10. Attach each side rail to the tractor frame with 4 - 3/4" x 6" bolts (PN: 16-20230), 8 - 3/4" flat washers (PN: 57-20747), and 4 - 3/4" nuts (PN: 70-20607) in the bottom holes.
 11. Once all bolts are installed, torque the front 20mm bolts to 432 ft-lbs., all 3/4" bolts to 257 ft-lbs., and all 1" bolts to 903 ft-lbs.
 12. Remove the 2 drawbar mount bolts that are located towards the front of the tractor
 13. Install a 3/4" x 2-1/2" bolt (PN: 16-20220) and 3/4" nut (PN: 70-20587) at the rear of the push pole. Turn the bolts in for installation. See attached diagram for any clarification.
 14. Lift the rear of the push pole up and attach to the drawbar mount with a 20mm x 120mm bolt (PN: 16-2489) and a 3/4" washer (PN: 57-20747) in both holes. Finger tighten only.
 15. Lift the front of the push pole up to the undercarriage and attach with 1" pin (PN: 43-1679), 2 - 1" flat washers (PN: 57-20749) and 2 - pin clips (PN: 43-7767).

16. Unscrew the 3/4" bolts at the rear of the push pole until they are tight against the drawbar mounting plate. Torque the bolts to 85-90 ft-lbs.
17. Torque the 20mm bolts at the rear of the undercarriage to 432 ft-lbs.
18. Tighten the nuts up tight against the push pole. Use the nuts to lock the bolts in place.
19. Start tractor and turn front tires from side to side and oscillate the axle, watching for interference between axle, tires and U/C. Adjust stops on tractor if necessary.
20. After first 8 hours of use, re-torque all bolts.
21. Check all fasteners regularly to ensure proper operation of equipment.

NOTE: After blade is installed, angle the blade to both sides and check for any interference with the tires. Adjust stops on tractor if necessary.

Hose Routing

NOTE: When routing hoses to the rear of the tractor always secure hoses and keep hoses away from moving parts



1. Run hoses through hose loops on undercarriage and push pole to the rear of the push pole.



2. Run hoses up next to the fuel tank and over the transmission.



3. Run hoses above the transmission and out behind the 3-point on the left side.



4. Run hoses up behind the valve and then back up over the valve from the right side between the cab and steel line. Plug hoses in. Verify that 3-point will not pinch any hoses.

THE INFORMATION CONTAINED IN THIS DRAWING IS THE SOLE PROPERTY OF GROUSER PRODUCTS INC ANY REPRODUCTION IN PART OR WHOLE WITHOUT THE WRITTEN PERMISSION OF GROUSER PRODUCTS INC IS PROHIBITED.

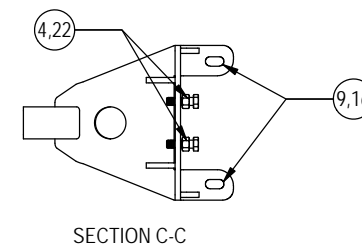
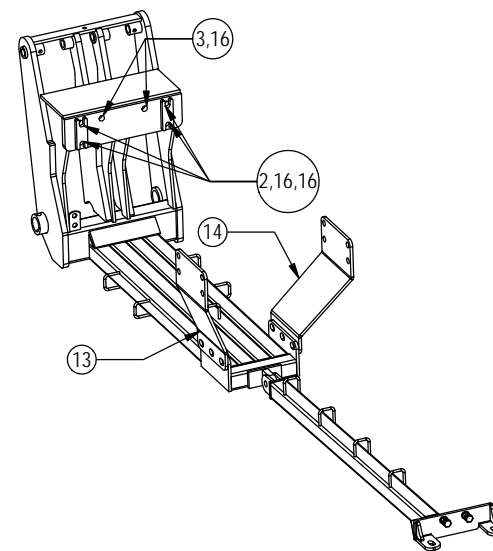
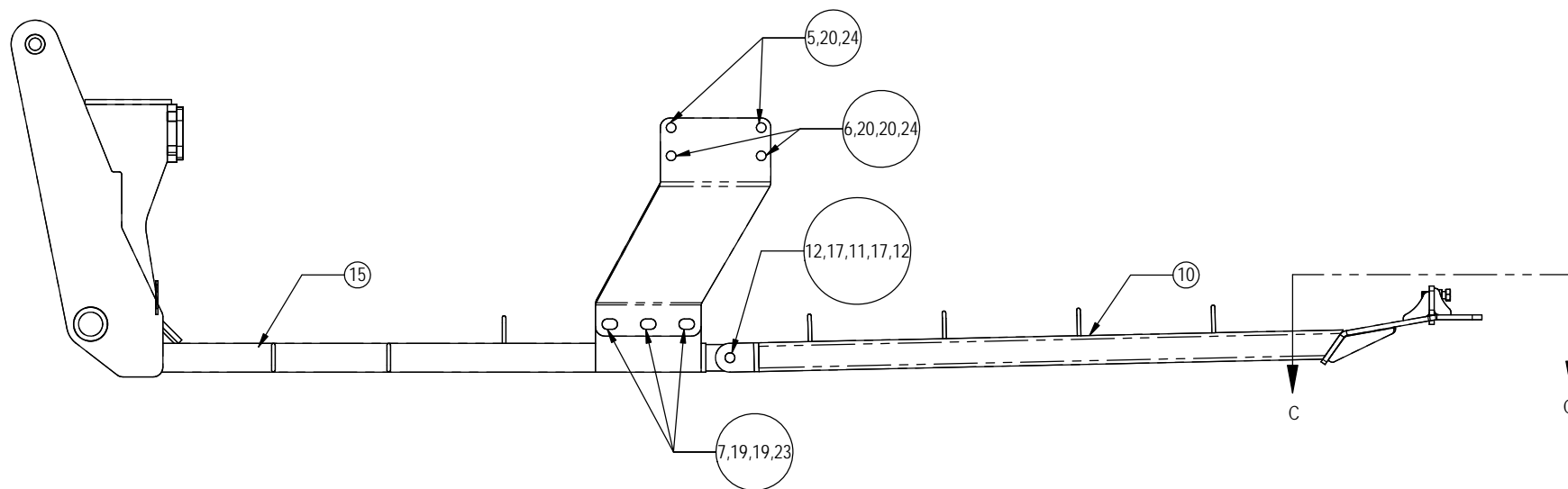

Item No.	Qty.	Part No.	Description
1	2	16-11127	1" x 13" Hex Bolt Gr 5 NC
2	4	16-1510	20mm x 2.5mm x 90mm Metric Hex Bolt Gr 10.9
3	2	16-1876	20mm x 2.5mm x 70mm Metric Hex Bolt Gr 10.9
4	2	16-20220	3/4" x 2-1/2" Hex Bolt Gr 5 NC
5	4	16-20222	3/4" x 3" Hex Bolt Gr 5 NC
6	4	16-20230	3/4" x 6" Hex Bolt Gr 5 NC
7	6	16-20558	1" x 2" Hex Bolt Gr 8 NC
8	2	16-3703	1" x 16" Hex Bolt Gr 8 NC
9	2	16-2489	20mm x 2.5mm x 120mm Metric Hex Bolt Gr 10.9
10	1	17-15610	Versatile Push Pole
11	1	43-16789	1" x 4" Pin with Holes
12	2	43-7767	Hitch Pin Clip
13	1	44-14063-L	Versatile Side Plate - Left
14	1	44-14063-R	Versatile Side Plate - Right
15	1	54-3345	Versatile Undercarriage
16	12	57-20747	3/4" Flat Washer
17	2	57-20749	1" Flat Washer
18	2	57-20759	1" SAE Hardened Flat Washer - 2" OD
19	12	57-20819	1" Heavy Duty Flat Washer Gr 8 (USS)
20	12	57-3680	2.00" O.D. x .75" I.D. x .375" Thick Washer
21	4	57-8835	2.50" O.D. x 1.05" I.D. x .50" Thick Washer
22	2	70-20587	3/4" Hex Nut
23	8	70-20599	1" Hex Nut
24	8	70-20607	3/4" Hex Center Lock Nut



GROUSER PRODUCTS INC.

755 2nd Ave NW Phone 701.282.7710
 West Fargo, ND 58078 Fax 701.282.8131
 WWW.GROUSER.COM

TITLE: FH-400 Versatile 250-305
 Ultrasteer UC - HD Drawbar Assy.

Date: 6/24/2013

DWG. NO.: 16882-a