



FH-440 Case Magnum T4A&B - Standard Axle w/ STD PST & CVT Series Undercarriage Installation Instructions

Caution:

- Always use precaution when working around any equipment.
 - Always wear safety glasses.
 - Follow tractor manufacturer's safety guidelines when installing this product.
1. Read all instructions prior to installation.
 2. Remove weights and weight bracket from front of tractor if necessary.
 3. Install 2 - 1" x 6" bolts (PN: 16-17271) and 2 - 1" nuts (PN: 70-20599) on the end of the undercarriage. Turn the 1" bolts in for installation. The bolts will be adjusted after the push pole is installed. See the attached diagram for proper installation of the bolts and nuts.
 4. Position the undercarriage (U/C) under the tractor and center with the frame of the tractor.
 5. Lift the U/C until the holes on the tractor line up with the holes on the U/C.
 6. At the front of the tractor, use 8 - 20mm x 70mm bolts (PN: 16-1876) with a 3/4" SAE flat washer (PN: 57-20757) on each bolt to attach the U/C to the front of the tractor. Tighten finger tight. See the attached diagram for any clarification.
 7. Use 7 - 20mm x 50mm bolts (PN: 16-1878) with a 3/4" flat washer (PN: 57-20747) on each bolt in the holes of the left rail (PN: 44-14933-L) to attach the left rail to the tractor frame.
 8. Use 7 - 20mm x 50mm bolts (PN: 16-1878) with a 3/4" flat washer (PN: 57-20747) on each bolt through the holes of the right rail to attach the right rail to the tractor frame.
 9. Attach the left and right rails to the rear of the undercarriage with 2 - 1" bolts (PN: 16-20560), 4 - 1" heavy duty flat washers (PN: 57-20819), and 2 - 1" nuts (PN: 70-20599) for each side.
 10. Once all bolts are installed, torque the front 20mm bolts to 432 ft-lbs.
 11. Torque the 20mm bolts on the side rails to 432 ft-lbs.
 12. Torque the 1" bolts attaching the side rails to the U/C to 903 ft-lbs.
 13. Position the push pole (PN: 17-14930) under the tractor. See the attached diagram for the correct orientation of the push pole.
 14. Slide the push pole onto the rod at the rear of the undercarriage.
 15. Lift the rear of the push pole up to the drawbar bracket.
 16. Screw in a 1" bolt on each side of the push pole all the way till they are tight and are resting on the top of the drawbar bracket.

- 17.** Push the push pole back tight against the drawbar bracket.
- 18.** Unscrew the two 1" x 6" bolts at the front of the push pole until they are tight against the push pole. Torque the 1" bolts to 90-95 ft-lbs.
- 19.** Tighten the nuts up tight against the push pole. Use the nuts to lock the bolts in place.
- 20.** After first 8 hours of use, re-torque all bolts.
- 21.** Check all fasteners regularly to ensure proper operation of equipment.

THE INFORMATION CONTAINED IN THIS DRAWING IS THE SOLE PROPERTY OF GROUSER PRODUCTS INC ANY REPRODUCTION IN PART OR WHOLE WITHOUT THE WRITTEN PERMISSION OF GROUSER PRODUCTS INC IS PROHIBITED.

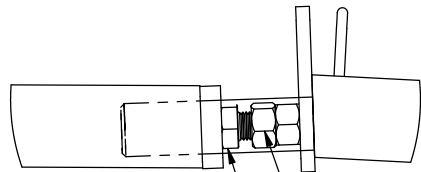

DETAIL A
SCALE 1:7

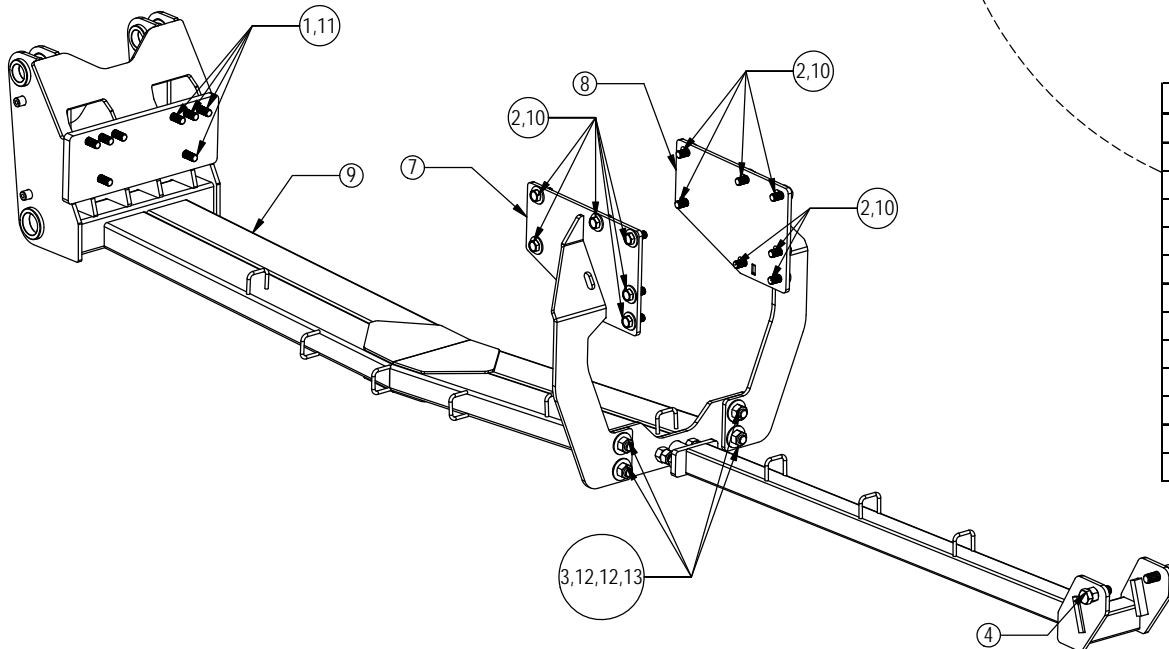
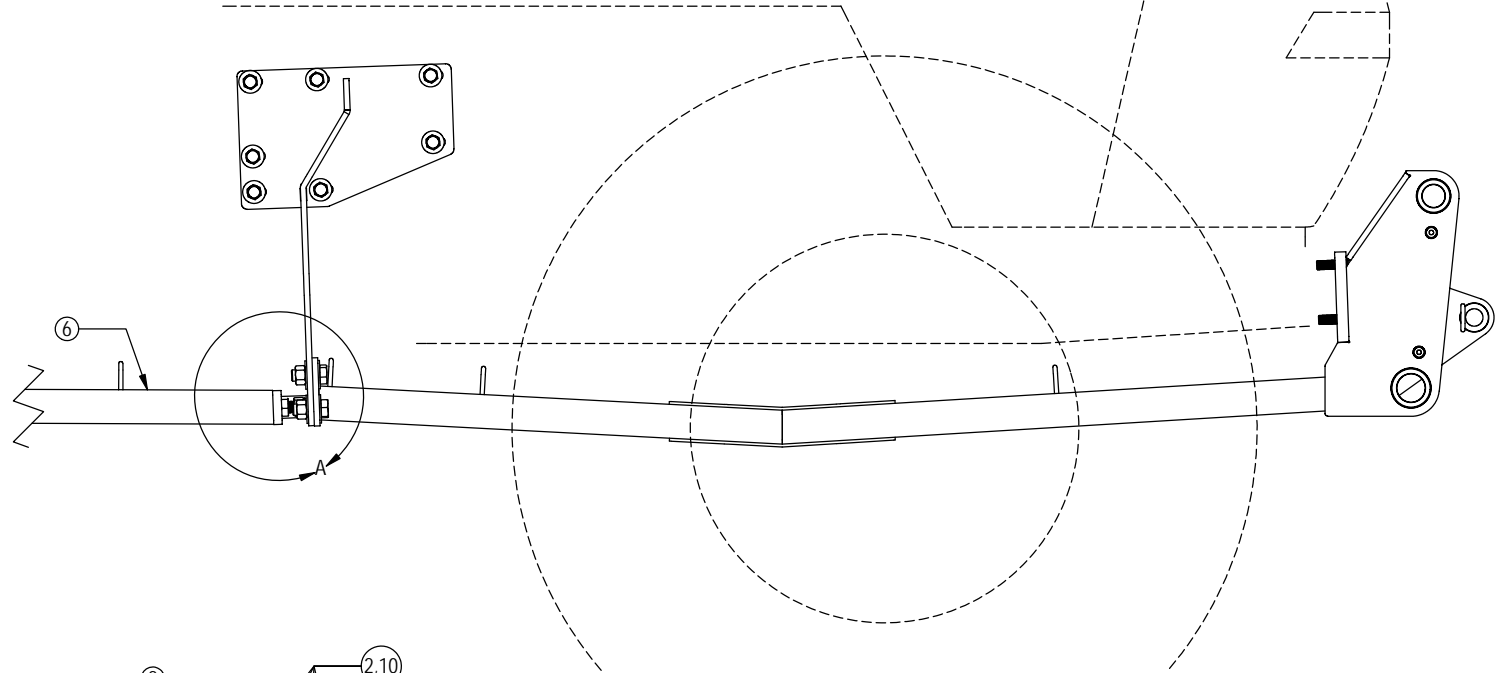
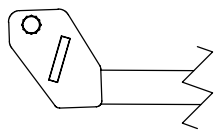

ITEM NO.	QTY.	PART NO.	DESCRIPTION
1	8	16-1876	20mm x 2.5mm x 70mm Metric Hex Bolt Gr 10.9
2	14	16-1878	20mm x 2.5mm x 50mm Metric Hex Bolt Gr 10.9
3	4	16-20560	1" x 2-1/2" Hex Bolt Gr 8 NC
4	2	16-20562	1" x 3" Hex Bolt Gr 8 NC
5	2	16-17271	1" x 6" Hex Bolt Gr 8 NC (Full Thread)
6	1	17-14930	Magnum T4A Push Pole
7	1	44-14933-L	Magnum T4A Side Plate,Left
8	1	44-14933-R	Magnum T4A Side Plate,Right
9	1	54-17595	Case Magnum T4A Undercarriage - Standard
10	14	57-20747	3/4" Flat Washer
11	8	57-20757	3/4" SAE Hardened Flat Washer - 1-1/2" OD
12	8	57-20819	1" Flat Washer Heavy Duty Gr 8 (USS)
13	6	70-20599	1" Hex Nut Gr 8 NC



GROUSER PRODUCTS INC.

755 2nd Ave NW Phone 701.282.7710
West Fargo, ND 58078 Fax 701.282.8131
WWW.GROUSER.COM

TITLE: Case Magnum T4A & T4B
Standard Axle

Date: 4/15/2014

DWG. NO.: 17595-A