



FH-400 CAT MT700E Series

Undercarriage Installation Instructions

Caution:

- Always use precaution when working around any equipment.
- Always wear safety glasses.
- Follow tractor manufacturer's safety guidelines when installing this product.
 1. Read all instructions prior to installation.
 2. Remove weights and weight bracket from front of tractor if necessary.
 3. Install 2 - 1" x 3-1/2" bolts (PN: 16-20564) and 2 - 1" nuts (PN: 70-20589) on the rear plate on the undercarriage. Tighten the bolt as far as it will go. See attached diagram for any clarification.
 4. Set the rear push plate (PN: 44-17688) over the rear tube and up against the bolts. This will be tightened up against the tractor frame in a later step.
 5. Position the undercarriage (U/C) under the tractor and center with the frame of the tractor.
 6. Lift the U/C until the holes on the tractor line up with the holes on the U/C.
 7. At the front of the tractor, start 8 - 20mm x 70mm bolts (PN: 16-1876) with a 3/4" heavy washer (PN: 57-3680) on each bolt in the holes. See attached diagram for any clarification.
 8. Start 8 - 20mm x 50mm bolts (PN: 16-1878) with a 3/4" heavy washer (PN: 57-3680) on each bolt in the holes of the first side plates and the tractor frame. Hand tighten until the washers are in contact with the U/C.
 9. Insert 8 - 7/8" x 2-1/2" bolts (PN: 16-20540) with a 7/8" heavy washer (PN: 57-3681) on each bolt through the holes of the second side plates and the tractor frame. Install a 7/8" heavy duty washer and hand tighten a 7/8" hex nut (PN: 70-20598) onto each bolt.
 10. Insert 8 - 7/8" x 3" bolts (PN: 16-20542) with a 7/8" heavy washer (PN: 57-3681) on each bolt through the holes of the third side plates and the tractor frame. Install a 7/8" heavy duty washer and hand tighten a 7/8" hex nut (PN: 70-20598) onto each bolt.
 11. Once all bolts are finger tight and the U/C lines up correctly with the tractor frame, torque all 7/8" bolts to 600 ft-lbs. and all 20mm bolts to 432 ft-lbs.
 12. Push the rear push plate up against the frame of the tractor. Unscrew the 1" x 3-1/2" bolts until they are tight against the rear push plate. Torque the 1" bolts to 90-95 ft-lbs.
 13. Tighten the nuts up tight against the push pole. Use the nuts to lock the bolts in place.
 14. Remove the 2 bolts from the pan underneath the tractor just behind where the undercarriage ends.
 15. Attach the rear bolt on plate (PN: 44-12655) to the undercarriage with 2 - 3/4" x 2" bolts (PN: 16-20218), 4 - 3/4" flat washers (PN: 57-20747), and 2 - 3/4" nuts (PN: 70-20607).
 16. Install 2 - 12mm x 35mm bolts (PN: 16-1217535) and 2 - 1/2" flat washers (PN: 57-20744) through the rear holes of the bolt on plate and of the holes that the bolts were removed from in Step #14. Torque the 3/4" bolts to 257 ft-lbs. and the 12mm bolts to 109 ft-lbs.
 17. After first 8 hours of use, re-torque all bolts.
 18. Check all fasteners regularly to ensure proper operation of equipment.

THE INFORMATION CONTAINED IN THIS DRAWING IS THE SOLE PROPERTY OF GROUSER PRODUCTS INC ANY REPRODUCTION IN PART OR WHOLE WITHOUT THE WRITTEN PERMISSION OF GROUSER PRODUCTS INC IS PROHIBITED.

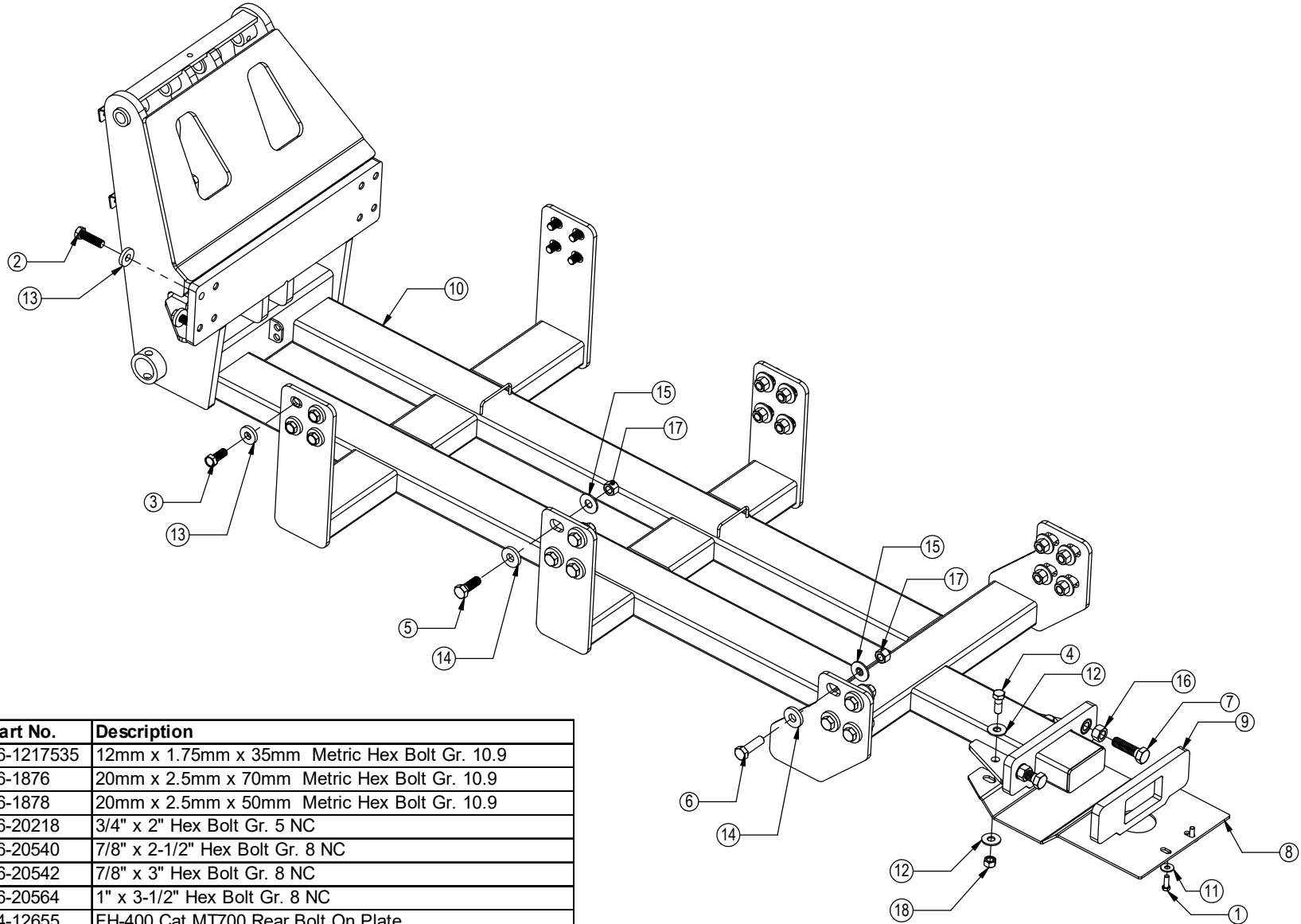

Item No.	Qty.	Part No.	Description
1	2	16-1217535	12mm x 1.75mm x 35mm Metric Hex Bolt Gr. 10.9
2	8	16-1876	20mm x 2.5mm x 70mm Metric Hex Bolt Gr. 10.9
3	8	16-1878	20mm x 2.5mm x 50mm Metric Hex Bolt Gr. 10.9
4	2	16-20218	3/4" x 2" Hex Bolt Gr. 5 NC
5	8	16-20540	7/8" x 2-1/2" Hex Bolt Gr. 8 NC
6	8	16-20542	7/8" x 3" Hex Bolt Gr. 8 NC
7	2	16-20564	1" x 3-1/2" Hex Bolt Gr. 8 NC
8	1	44-12655	FH-400 Cat MT700 Rear Bolt On Plate
9	1	44-17688	FH-400 Cat MT700 Plate, Rear Push
10	1	54-17670	FH-400 UC Challenger MT700E
11	2	57-20744	1/2" Flat Washer
12	4	57-20747	3/4" Flat Washer
13	16	57-3680	2.00" OD x .75" ID x .375" Heavy Washer CZ Plated
14	16	57-3681	2.25" OD x .875" ID x .375" Heavy Washer CZ Plated
15	16	57-20818	7/8" Flat Washer Heavy Duty Gr 8 (USS)
16	2	70-20589	1" Hex Nut Gr. 5 NC
17	16	70-20598	7/8" Hex Nut Gr. 8 NC
18	2	70-20607	3/4" Hex Center Lock Nut Gr 2 NC



GROUSER PRODUCTS INC.

755 2nd Ave NW Phone 701.282.7710
 West Fargo, ND 58078 Fax 701.282.8131
 WWW.GROUSER.COM

TITLE CAT MT 700E Mounting Inst.		DWG. NO. 17670-A
Date: 2/2/2015	Scale: 1:16	Sheet: 1