



# FH-440 New Holland T8 - T4A&B - Standard Axle w/ STD PST & CVT Series Undercarriage Installation Instructions

## Caution:

- Always use precaution when working around any equipment.
- Always wear safety glasses.
- Follow tractor manufacturer's safety guidelines when installing this product.
  1. Read all instructions prior to installation.
  2. Remove front 3-point or weights and weight bracket from front of tractor if necessary.
  3. Install 2 - 1" x 6" bolts (PN: 16-17271) and 2 - 1" nuts (PN: 70-20599) on the end of the undercarriage. Turn the 1" bolts in for installation. The bolts will be adjusted after the push pole is installed. See the attached diagram for proper installation of the bolts and nuts.
  4. Position the undercarriage (U/C) under the tractor and center with the frame of the tractor.
  5. Lift the U/C until the holes on the tractor line up with the holes on the U/C.
  6. At the front of the tractor, use 6 - 20mm x 70mm bolts (PN: 16-1876) with a 3/4" SAE flat washer (PN: 57-20757) on each bolt for the bottom 6 holes to attach the U/C to the front of the tractor. Tighten finger tight. See the attached diagram for any clarification.
  7. For the top 2 holes, use 2 - 24mm x 150mm bolts (PN: 16-1875), 4 - 1" SAE flat washer (PN: 57-20759) and 2 - 24mm nuts (PN: 70-20874). Tighten finger tight. See the attached diagram for any clarification.
  8. Modifications are needed to reattach the pads on the side of the tractor frame where the side rails are attached. Refer to the attached diagram for further information.
  9. Use 10 - 20mm x 70mm bolts (PN: 16-1876) with a 3/4" flat washer (PN: 57-20747) on each bolt in the holes of the left and right rail (PN: 44-14980-R,L) to attach the rails to the tractor frame.
  10. If there is a ground boss where the rails are attached to the tractor, use the 20mm x 120mm bolt (PN: 16-2489) with a 3/4" washer (PN: 57-20747) along with the ground boss instead of a 20mm x 70mm bolt.
  11. Attach the left and right rails to the rear of the undercarriage with 2 - 1" bolts (PN: 16-20560), 4 - 1" heavy duty flat washers (PN: 57-20819), and 2 - 1" nuts (PN: 70-20599) for each side.
  12. Once all bolts are installed, torque the front 20mm bolts to 432 ft-lbs., the 24mm bolts to 909 ft-lbs., the 20mm bolts on the side rails to 432 ft-lbs., and the 1" bolts attaching the side rails to the U/C to 903 ft-lbs.
  13. Position the push pole (PN: 17-14930) under the tractor. Slide the push pole onto the rod at the rear of the undercarriage. See the attached diagram for the correct orientation of the push pole.
  14. Lift the rear of the push pole up to the drawbar bracket. Screw in a 1" x 3" bolt (PN: 16-20562) on each side of the push pole all the way till they are tight and are resting on the top of the drawbar bracket.
  15. Push the push pole back tight against the drawbar bracket.
  16. Unscrew the two 1" x 6" bolts at the front of the push pole until they are tight against the push pole. Torque the 1" bolts to 90-95 ft-lbs.
  17. Tighten the nuts up tight against the push pole. Use the nuts to lock the bolts in place.
  18. After first 8 hours of use, re-torque all bolts.
  19. Check all fasteners regularly to ensure proper operation of equipment.

THE INFORMATION CONTAINED IN THIS DRAWING IS THE SOLE PROPERTY OF GROUSER PRODUCTS INC ANY REPRODUCTION IN PART OR WHOLE WITHOUT THE WRITTEN PERMISSION OF GROUSER PRODUCTS INC IS PROHIBITED.

Modifications are needed for the pad bolted to the side of the tractor frame. The rear holes on the pad need to be cut out as shown here. Measurements are supplied here as guidelines. You may have to cut more or a little less. You need to keep some material to fit between the spacers behind the supplied undercarriage side rails and the pad is still held on by one of the original bolts.

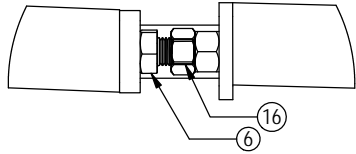

DETAIL A  
SCALE 1:7

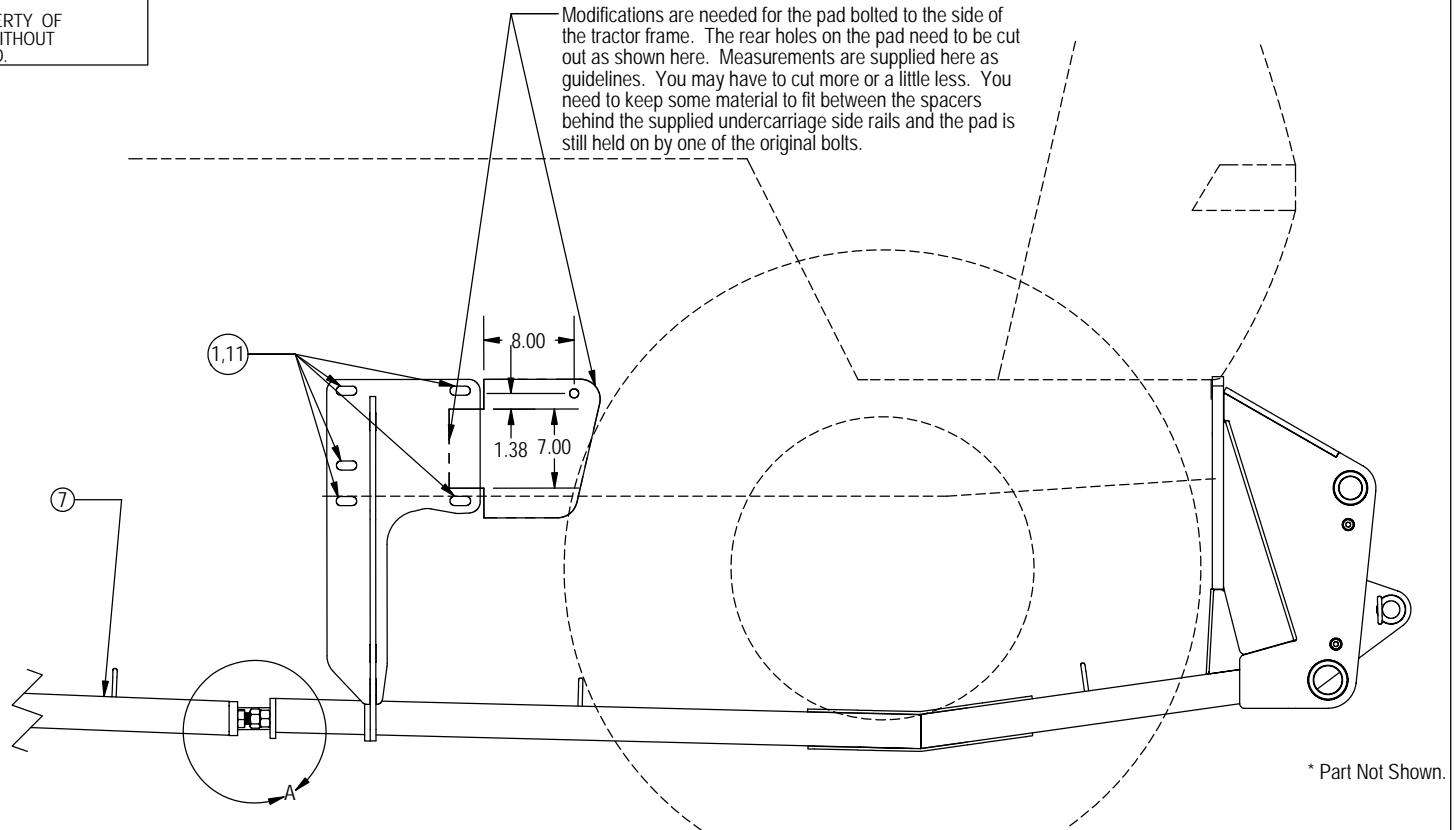

\* Part Not Shown.

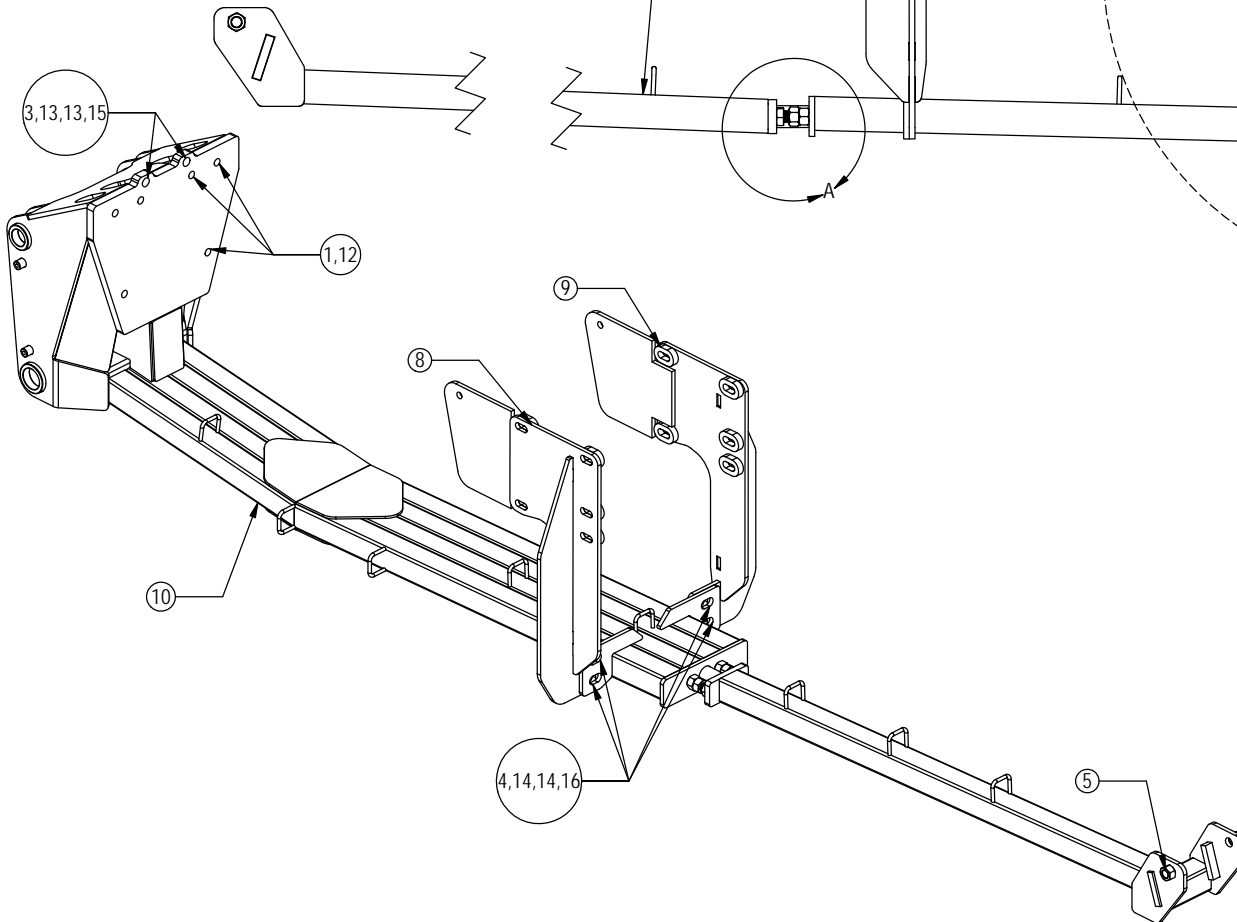

ITEM NO.	QTY.	PART NO.	DESCRIPTION
1	16	16-1876	20mm x 2.5mm x 70mm Metric Hex Bolt Gr 10.9
2*	1	16-2489	20mm x 2.5mm x 120mm Metric Hex Bolt Gr 10.9
3	2	16-1875	24mm x 3.0mm x 150mm Metric Hex Bolt Gr 10.9 ZC
4	4	16-20560	1" x 2-1/2" Hex Bolt Gr 8 NC
5	2	16-20562	1" x 3" Hex Bolt Gr 8 NC
6	2	16-17271	1" x 6" Hex Bolt Gr 8 NC (Full Thread)
7	1	17-14930	Magnum T4A/B & NH T8 Push Pole
8	1	44-14980-L	NH T8 Side Plate, Left
9	1	44-14980-R	NH T8 Side Plate, Right
10	1	54-17710	NH T8 Undercarriage - Standard Axle
11	10	57-20747	3/4" Flat Washer
12	6	57-20757	3/4" SAE Hardened Flat Washer - 1-1/2" OD
13	4	57-20759	1" SAE Hardened Flat Washer - 2" OD
14	8	57-20819	1" Flat Washer Heavy Duty Gr 8 (USS)
15	2	70-20874	24mm Hex Nut 3.0 Pitch CL8 ZC
16	6	70-20599	1" Hex Nut Gr 8 NC



**GROUSER PRODUCTS INC.**

755 2nd Ave NW Phone 701.282.7710  
West Fargo, ND 58078 Fax 701.282.8131  
WWW.GROUSER.COM

TITLE: FH-440 NH T8 T4A&B- Std Axle

Date: 4/16/2014

DWG. NO.: 17710-A