



New Holland T8 Front Support - T4A & B w/ HD PST & CVT - TerraGlide Series

Undercarriage Installation Instructions

Caution:

- Always use precaution when working around any equipment.
- Always wear safety glasses.
- Follow tractor manufacturer's safety guidelines when installing this product.
 1. Read all instructions prior to installation.
 2. Install 2 - 1" x 6" bolts (PN: 16-17271) and 2 - 1" nuts (PN: 70-20599) on the end of the front support. Turn the 1" bolts in for installation. The bolts will be adjusted after the push pole is installed. See the attached diagram for proper installation of the bolts and nuts.
 3. If the tractor has the saddle axle, go to Step #5.
 4. If the tractor has the scissor axle, remove the accumulator bracket that hangs down right behind the lift arms on the front 3-point and attach the new supplied brackets in it's place and reattach the accumulator to the new bracket. Attach the left and right brackets together with a 3/8" flange bolt (PN: 16-35C616) and nut (PN: 70-20622).
 5. Position the front support under the tractor and center with the frame of the tractor.
 6. Support the front linkage frame and remove the 2 pivot pins that hold the lift arms to the frame.
 7. Lift the front of the front support. Once the ears are aligned with the frame and the lift arms of the front 3-point, insert the front push pole pins (PN: 43-18015) on each side.
 8. Once the pins are in place, insert a spacer (PN: 19-13515) in the open space between the legs of each pin head. Insert a 3/4" bolt (PN: 16-20216) with a 3/4" flat washer (PN: 57-20747) through the spacer and the hole of the push pole. See attached diagram for clarification.
 9. Modifications are needed to reattach the pads on the side of the tractor frame where the side rails are attached. Refer to the attached diagram for further information.
 10. Use 10 - 20mm x 70mm bolts (PN: 16-1876) with a 3/4" flat washer (PN: 57-20747) on each bolt in the holes of the left and right rail (PN: 44-14980-R,L) to attach the rails to the tractor frame.
 11. If there is a ground boss where the rails are attached to the tractor, use the 20mm x 120mm bolt (PN: 16-2489) with a 3/4" washer (PN: 57-20747) along with the ground boss instead of a 20mm x 70mm bolt.
 12. Attach the left and right rails to the rear of the undercarriage with 2 - 1" bolts (PN: 16-20560), 4 - 1" heavy duty flat washers (PN: 57-20819), and 2 - 1" nuts (PN: 70-20599) for each side.
 13. Once all bolts are installed, torque the front 3/4" bolts to 257 ft-lbs., the 20mm bolts on the side rails to 432 ft-lbs., and the 1" bolts attaching the side rails to the U/C to 903 ft-lbs.
 14. Position the push pole (PN: 17-15875) under the tractor. See the attached diagram for the correct orientation of the push pole.
 15. Slide the push pole onto the rod at the rear of the undercarriage. Lift the rear of the push pole up to the drawbar bracket.
 16. Screw in a 1" x 3" bolt (PN: 16-20562) on each side of the push pole all the way till they are tight and are resting on the top of the drawbar bracket.
 17. Push the push pole back tight against the drawbar bracket.
 18. Unscrew the two 1"x6" bolts at the front of the push pole until they are tight against the push pole. Torque the 1" bolts to 90-95 ft-lbs.
 19. Tighten the nuts up tight against the push pole. Use the nuts to lock the bolts in place.
 20. After first 8 hours of use, re-torque all bolts.
 21. Check all fasteners regularly to ensure proper operation of equipment.

THE INFORMATION CONTAINED IN THIS DRAWING IS THE SOLE PROPERTY OF GROUSER PRODUCTS INC ANY REPRODUCTION IN PART OR WHOLE WITHOUT THE WRITTEN PERMISSION OF GROUSER PRODUCTS INC IS PROHIBITED.

Modifications are needed for the pad bolted to the side of the tractor frame. The rear holes on the pad need to be cut out as shown here. Measurements are supplied here as guidelines. You may have to cut more or a little less. You need to keep some material to fit between the spacers behind the supplied undercarriage side rails and the pad is still held on by one of the original bolts.

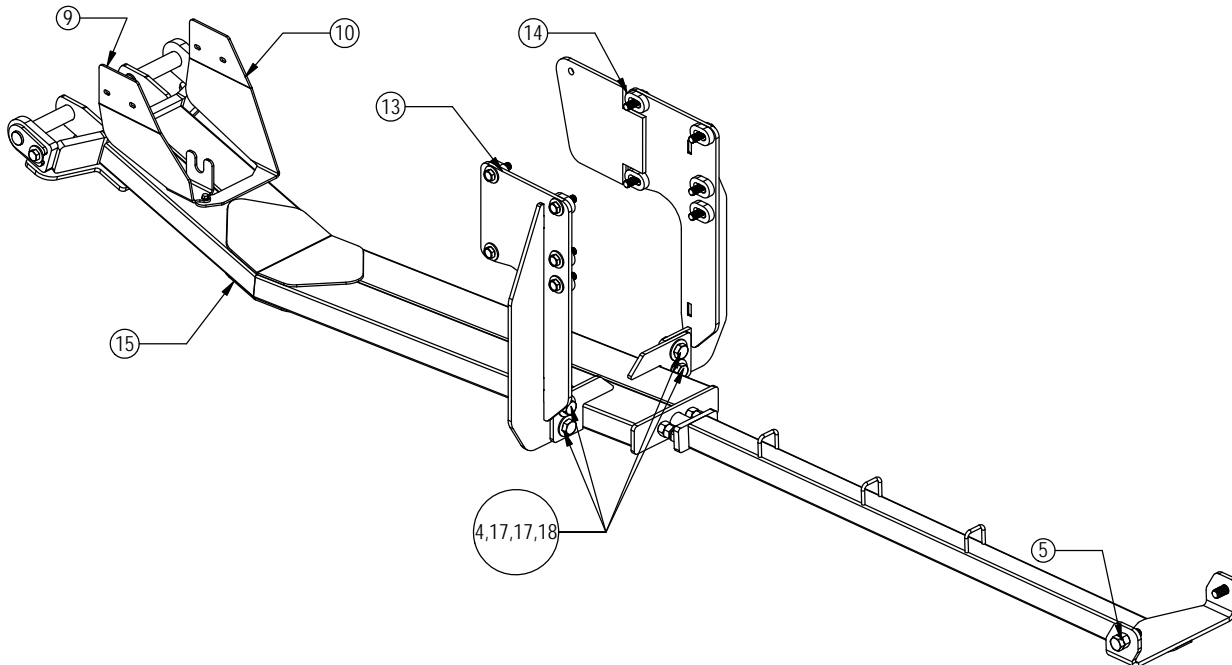
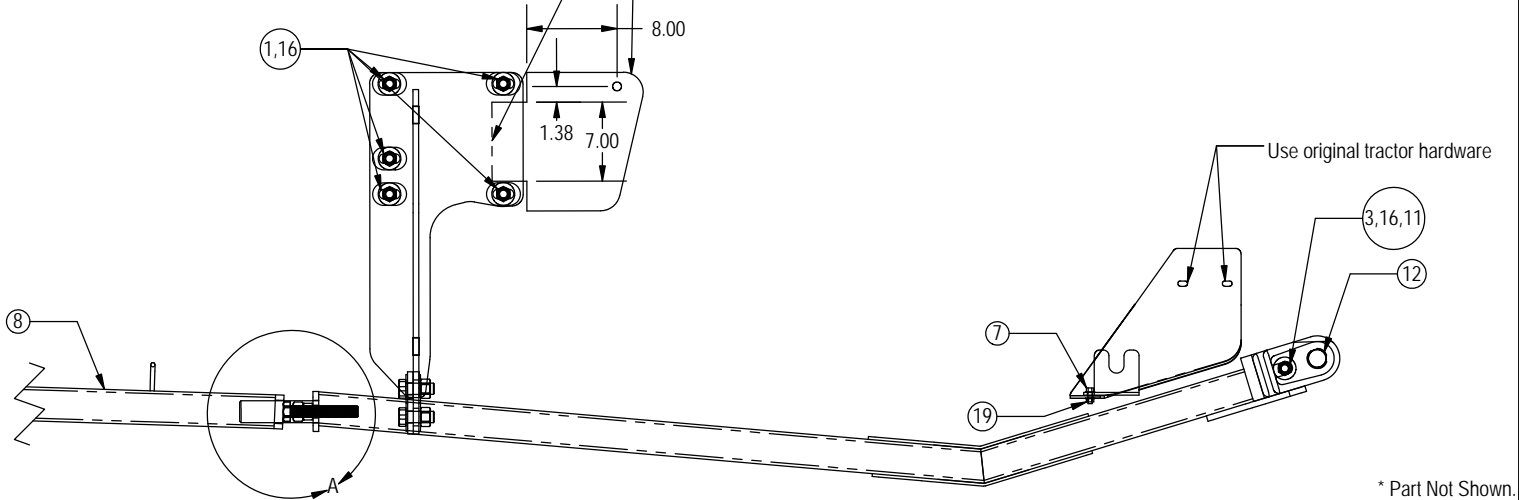
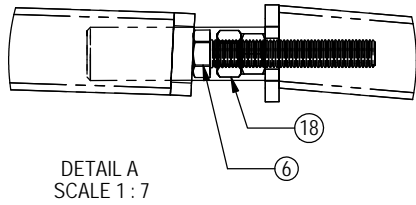

ITEM NO.	QTY.	PART NO.	DESCRIPTION
1	10	16-1876	20mm x 2.5mm x 70mm Metric Hex Bolt Gr 10.9
2*	1	16-2489	20mm x 2.5mm x 120mm Metric Hex Bolt Gr 10.9
3	2	16-20216	3/4" x 1-1/2" Hex Bolt Gr 5 NC
4	4	16-20560	1" x 2-1/2" Hex Bolt Gr 8 NC
5	2	16-20562	1" x 3" Hex Bolt Gr 8 NC
6	2	16-17271	1" x 6" Hex Bolt Gr 8 NC (Full Thread)
7	1	16-35C616	3/8" x 1" Flanged Bolt
8	1	17-15875	Magnum & NH T8 HD Push Pole
9	1	18-18017	Bracket for Accumulator - Left
10	1	18-18018	Bracket for Accumulator - Right
11	2	19-13515	3/4" ID Non Rotating Pin Spacer
12	2	43-18015	NH T8 Front Support Pin Weld
13	1	44-14980-L	NH T8 Side Plate, Left
14	1	44-14980-R	NH T8 Side Plate, Right
15	1	54-18005	NH T8 T4A&B Terraglide Axle Front Support
16	12	57-20747	3/4" Flat Washer
17	8	57-20819	1" Flat Washer Heavy Duty Gr 8 (USS)
18	6	70-20599	1" Hex Nut Gr 8 NC
19	1	70-20622	3/8" Flange Hex Nut



GROUSER PRODUCTS INC.

755 2nd Ave NW Phone 701.282.7710
 West Fargo, ND 58078 Fax 701.282.8131
 WWW.GROUSER.COM

TITLE: **NH T8 T4A&B HD**
Rear Axle - Terraglide Front Axle

Date: 6/5/2015

DWG. NO.: 18005-A



Torque Arm - Front Hitch

Installation Instructions

Caution:

- Always use precaution when working around any equipment.
- Always wear safety glasses.
- Follow tractor manufacturer's safety guidelines when installing this product.
- Read all instructions prior to installation.
 1. Set the front hitch arms to the fixed position. The front hitch arms cannot be in float with the torque arm installed.
 2. Position the torque arm between the front hitch arms. The longest edge of the plate should be closest to the tractor and the angled edge on the bottom. See the photo below for correct orientation.
 3. Support the torque arm and install a bolting plate with 4 - 3/4" x 3-1/2" bolts and 4 - 3/4" nuts on each side.
 4. Once the bolts are all installed, push the torque arm evenly towards the tractor. Keep the torque arm parallel to the front of the tractor.
 5. Torque the 3/4" bolts to 100 ft-lbs.
 6. After first 8 hours of use, re-torque all bolts.
 7. Check all fasteners regularly to ensure proper operation of equipment.

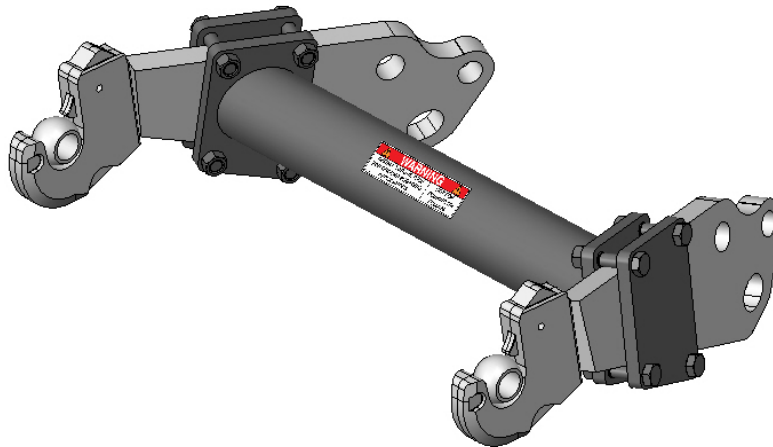

Note: The style of front hitch arms may vary slightly.



THE INFORMATION CONTAINED IN THIS DRAWING IS THE SOLE PROPERTY OF GROUSER PRODUCTS INC ANY REPRODUCTION IN PART OR WHOLE WITHOUT THE WRITTEN PERMISSION OF GROUSER PRODUCTS INC IS PROHIBITED.

ITEM NO.	QTY.	PART NO.	DESCRIPTION
1	1	11-19719	Torque Arm
2	8	16-20224	3/4" x 3-1/2" Gr.5 Hex Bolt NC
3	1	27-40405	Warning Decal - Torque Arm
4	2	44-19716	Plate
5	8	70-20607	3/4" Center Lock Hex Nut NC

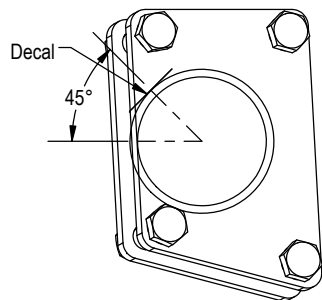
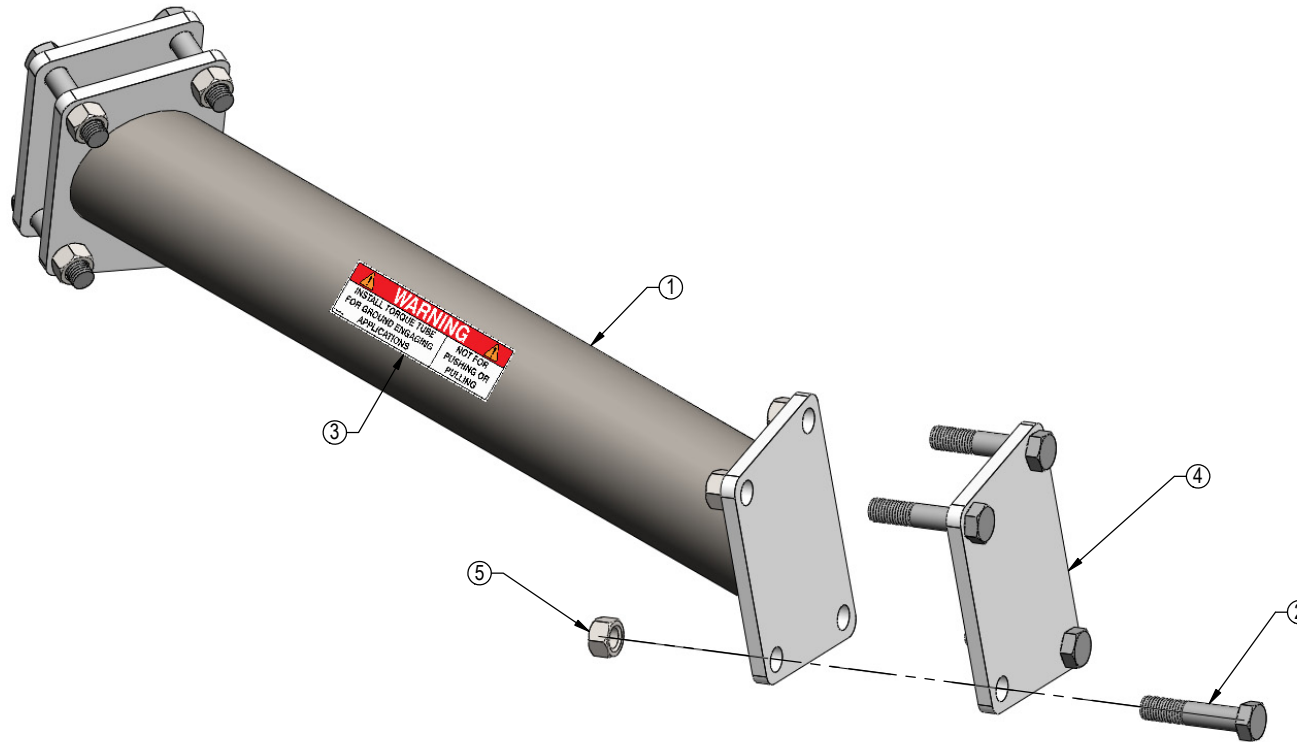

Placement of Warning Decal



GROUSER PRODUCTS INC.

755 2nd Ave NW Phone 701.282.7710
 West Fargo, ND 58078 Fax 701.282.8131
 WWW.GROUSER.COM

TITLE: Torque Arm for Front Hitches

Date: 2-16-2017

DWG. NO.: 19719-A