



FH-440 Case MX Magnum Tier 3 Standard Axle

Undercarriage Installation Instructions

Caution:

- Always use precaution when working around any equipment.
- Always wear safety glasses.
- Follow tractor manufacturer's safety guidelines when installing this product.
 1. Read all instructions prior to installation.
 2. Remove weights and weight bracket from front of tractor if necessary.
 3. Install 2 - 1" x 3" bolts (PN: 16-20562) and 2 - 1" nuts (PN: 70-20599) on the end of the undercarriage.
 4. Turn the 1" bolts in for installation. The bolts will be adjusted after the push pole is installed. See the attached diagram for proper installation of the bolts and nuts.
 5. Position the undercarriage (U/C) under the tractor and center with the frame of the tractor.
 6. Lift the U/C until the holes on the tractor line up with the holes on the U/C.
 7. At the front of the tractor, use 8 - 20mm x 70mm bolts (PN: 16-1876) with a 3/4" SAE flat washer (PN: 57-20757) on each bolt to attach the U/C to the front of the tractor. Tighten finger tight. See the attached diagram for any clarification.
 8. Use 2 - 20mm x 60mm bolts (PN: 16-2487) with a 3/4" flat washer (PN: 57-20747) on each bolt in the holes of the left side bracket (PN: 44-17625) to attach the left bracket to the tractor frame.
 9. Remove the ground boss from the right side of the tractor. The boss will be reinstalled in Step #11.
 10. Use 2 - 20mm x 60mm bolts (PN: 16-2487) with a 3/4" flat washer (PN: 57-20747) on each bolt in the top 2 holes of the right side bracket (PN: 44-17624) to attach the right bracket to the tractor frame.
 11. Use 1 - 20mm x 100mm bolt (PN: 16-1877) with the ground boss and a 3/4" flat washer (PN: 57-20747) through the bottom hole of the right side bracket to attach the right rail to the tractor frame. See the attached diagram for any clarification.
 12. Attach the left and right side brackets to the undercarriage with 2 - 1" bolts (PN: 16-20560), 4 - 1" heavy duty flat washers (PN: 57-20819), and 2 - 1" nuts (PN: 70-20599) for each side.
 13. Once all bolts are installed, torque the front 20mm bolts to 432 ft-lbs.
 14. Torque the 20mm bolts on the side rails to 432 ft-lbs.
 15. Torque the 1" bolts attaching the side brackets to the U/C to 903 ft-lbs.
 16. Remove and discard the front 2 bolts of the front drawbar pivot bracket.
 17. Position the push pole (PN: 17-17615) under the tractor. See the attached diagram for the correct orientation of the push pole

18. Slide the push pole onto the rod at the rear of the undercarriage.
19. Lift the rear of the push pole up to the drawbar bracket. Support the rear of the push pole with a floor jack or block.
20. Install the push pole hanger plate (PN: 44-17620) where you removed the bolts from the drawbar pivot bracket to hold up the rear of the push pole.
21. Place 2 - 3/4" SAE flat washers (PN: 57-20757) between the front drawbar pivot bracket and the push pole hanger plate. The hanger plate should be installed so the chamfered holes are facing down.
22. Use 2 - 20mm flat socket head cap screws (PN: 16-13405) to bolt the push pole hanger plate to the drawbar pivot bracket and the tractor rear axle housing.
23. Torque the 20mm flat socket head cap screws 577-607 N-m (425-447 ft-lbs.).
24. Push the push pole as far back as possible.
25. Unscrew the two 1" x 3" bolts at the front of the push pole until they are tight against the push pole. Torque the 1" bolts to 90-95 ft-lbs.
26. Tighten the nuts up tight against the push pole. Use the nuts to lock the bolts in place.
27. After first 8 hours of use, re-torque all bolts.
28. Check all fasteners regularly to ensure proper operation of equipment.

Warning: Fully oscillate the blade angle, tilt, steering, suspension and rear 3-point to check for adequate clearance. If necessary, add oscillation stops or purchase and install steering stops from your local dealership to avoid collision and subsequent damage.

The minimum clearance between any part on the blade and the front tires when the blade is fully angled, should be 3". If more clearance is necessary between the blade and the front tires, call Grouser Products.

THE INFORMATION CONTAINED IN THIS DRAWING IS THE SOLE PROPERTY OF GROUSER PRODUCTS INC ANY REPRODUCTION IN PART OR WHOLE WITHOUT THE WRITTEN PERMISSION OF GROUSER PRODUCTS INC IS PROHIBITED.

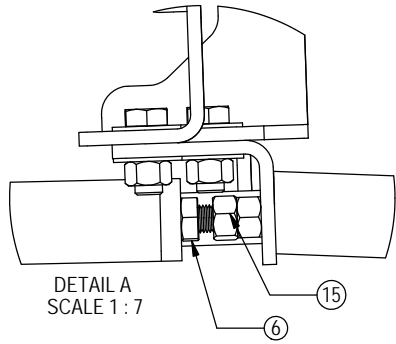

DETAIL A
SCALE 1:7

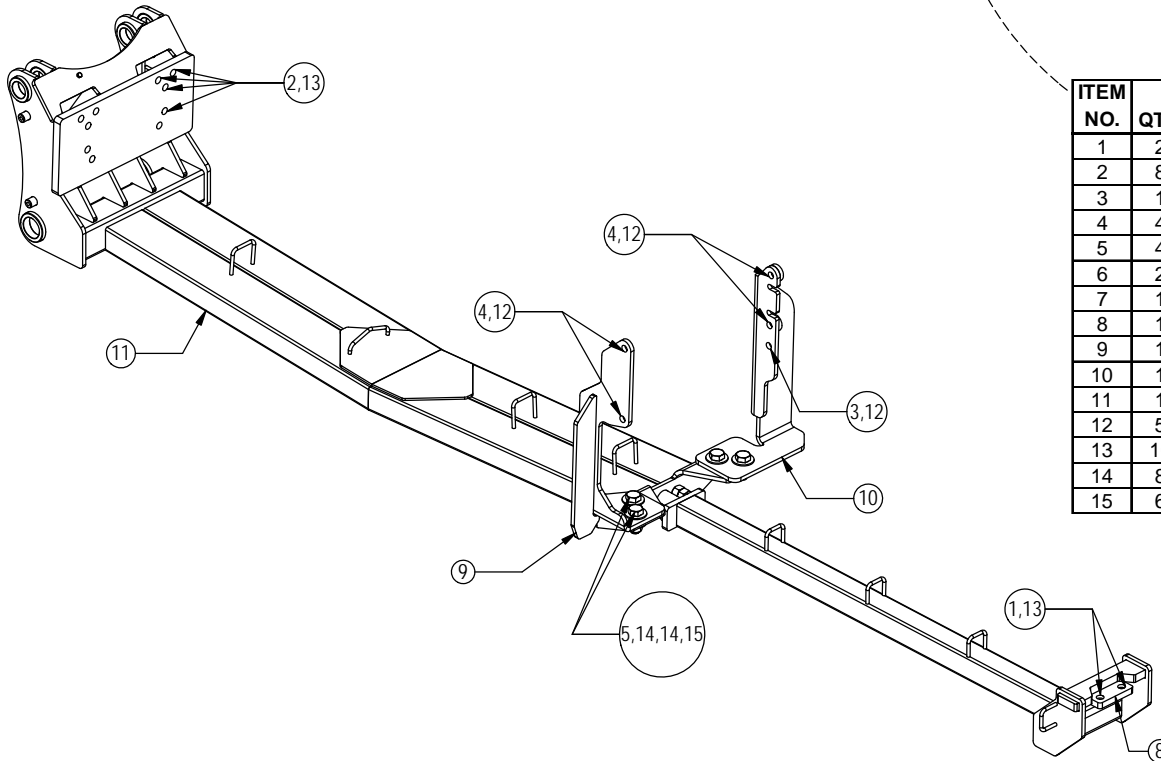
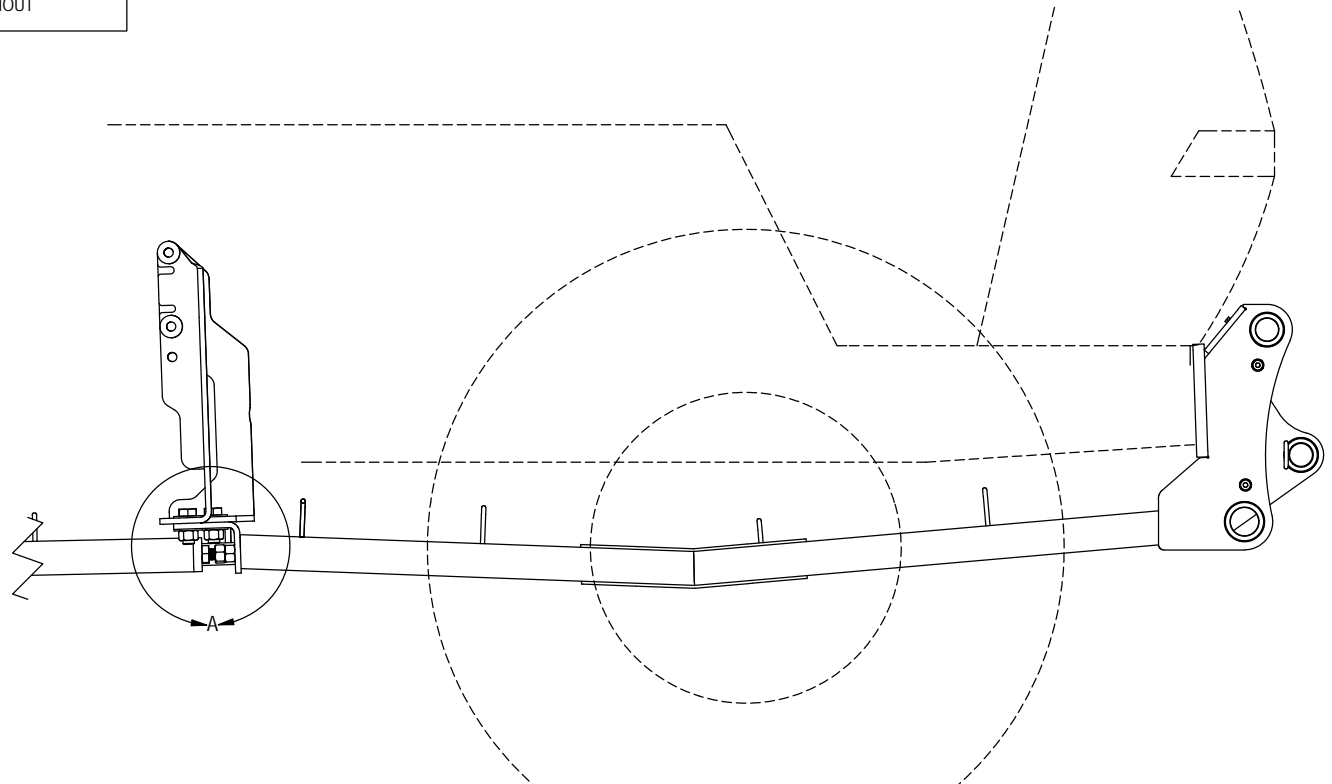
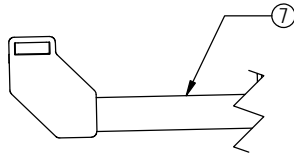

ITEM NO.	QTY.	PART NO.	DESCRIPTION
1	2	16-13405	20mm x 2.5 mm x 90mm (10.9) Flat Socket Head Cap Screw
2	8	16-1876	20mm x 2.5mm x 70mm Metric Hex Bolt Gr 10.9
3	1	16-1877	20mm x 2.5mm x 100mm Metric Hex Bolt Gr 10.9
4	4	16-2487	20mm x 2.5mm x 60mm Metric Hex Bolt Gr 10.9
5	4	16-20560	1" x 2-1/2" Hex Bolt Gr 8 NC
6	2	16-20562	1" x 3" Hex Bolt Gr 8 NC
7	1	17-17615	FH-440 Case Magnum T3 Lg Frame Push Pole
8	1	44-17620	FH-440 Case Magnum Push Pole Hanger Plate (Tier 3 Lg Frame)
9	1	44-17625	FH-440 Case Magnum Tier 3, Tier 4A/B Mid Frame Side Bracket, Left
10	1	44-17634	FH-440 Case Magnum Tier 3, Tier 4A/B Mid Frame Side Bracket, Right
11	1	54-18325	FH-440 Case Magnum Tier 3, Tier 4A/B Mid Frame Std. Axle UC
12	5	57-20747	3/4" Flat Washer
13	10	57-20757	3/4" SAE Hardened Flat Washer - 1-1/2" OD
14	8	57-20819	1" Flat Washer Heavy Duty Gr 8 (USS)
15	6	70-20599	1" Hex Nut Gr 8 NC



GROUSER PRODUCTS INC.

755 2nd Ave NW Phone 701.282.7710
West Fargo, ND 58078 Fax 701.282.8131
WWW.GROUSER.COM

TITLE: FH-440 Magnum T3 Std Axle

Date: 3/17/2015

DWG. NO.: 18840-A