



# Torque Arm - Front Hitch

## Installation Instructions

### Caution:

- Always use precaution when working around any equipment.
- Always wear safety glasses.
- Follow tractor manufacturer's safety guidelines when installing this product.
- Read all instructions prior to installation.
  1. Set the front hitch arms to the fixed position. The front hitch arms cannot be in float with the torque arm installed.
  2. Position the torque arm between the front hitch arms. The longest edge of the plate should be closest to the tractor and the angled edge on the bottom. See the photo below for correct orientation.
  3. Support the torque arm and install a bolting plate with 4 - 3/4" x 3-1/2" bolts and 4 - 3/4" nuts on each side.
  4. Once the bolts are all installed, push the torque arm evenly towards the tractor. Keep the torque arm parallel to the front of the tractor.
  5. Torque the 3/4" bolts to 100 ft-lbs.
  6. After first 8 hours of use, re-torque all bolts.
  7. Check all fasteners regularly to ensure proper operation of equipment.

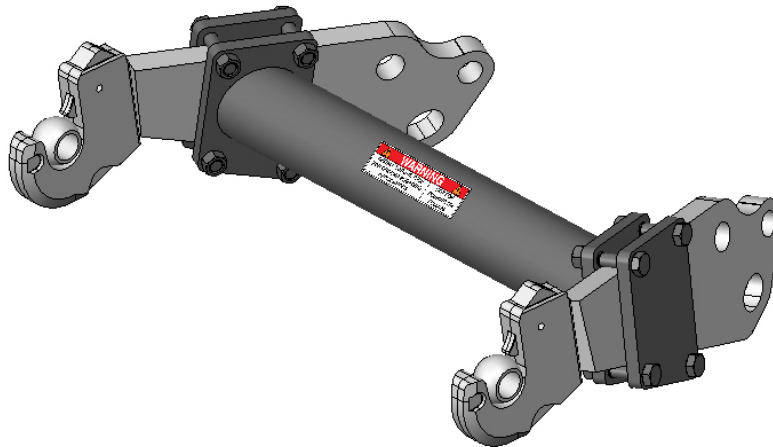

Note: The style of front hitch arms may vary slightly.



THE INFORMATION CONTAINED IN THIS DRAWING IS THE SOLE PROPERTY OF GROUSER PRODUCTS INC ANY REPRODUCTION IN PART OR WHOLE WITHOUT THE WRITTEN PERMISSION OF GROUSER PRODUCTS INC IS PROHIBITED.

ITEM NO.	QTY.	PART NO.	DESCRIPTION
1	1	11-19719	Torque Arm
2	8	16-20224	3/4" x 3-1/2" Gr.5 Hex Bolt NC
3	1	27-40405	Warning Decal - Torque Arm
4	2	44-19716	Plate
5	8	70-20607	3/4" Center Lock Hex Nut NC

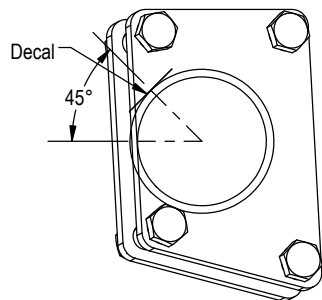
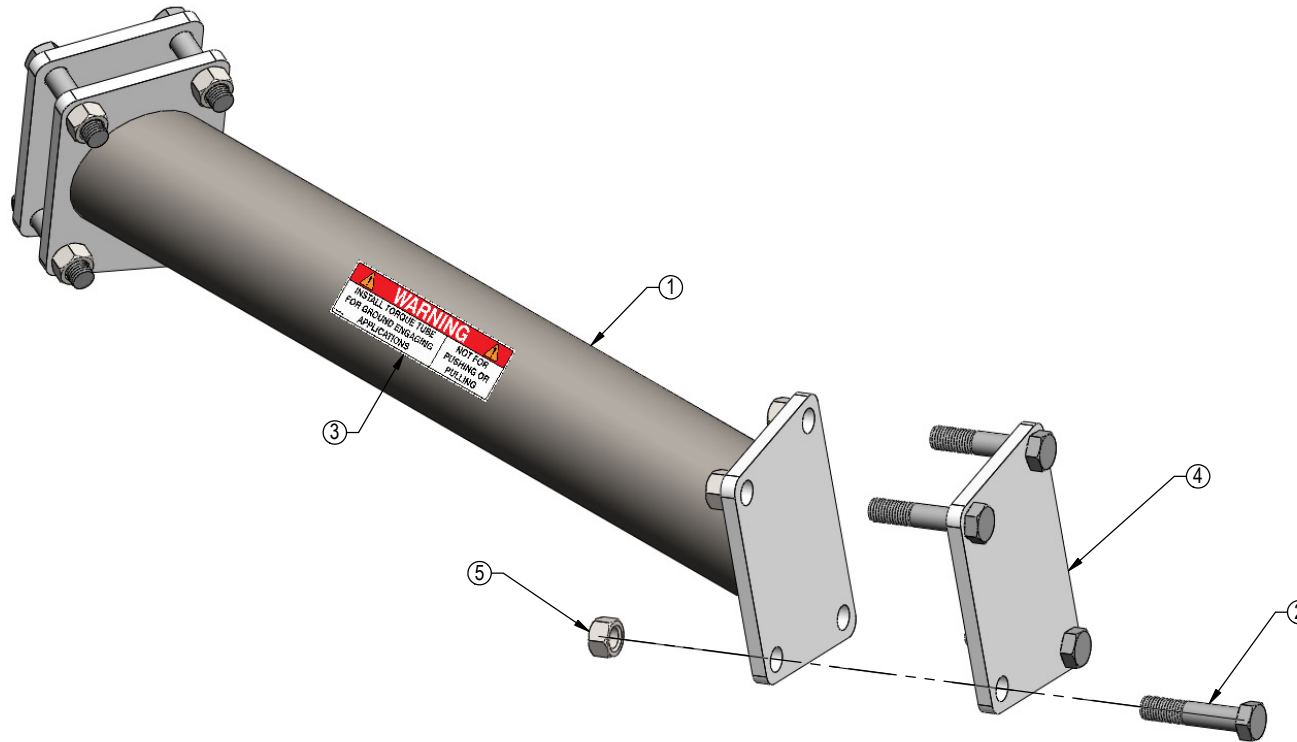

Placement of Warning Decal



**GROUSER PRODUCTS INC.**

755 2nd Ave NW Phone 701.282.7710  
 West Fargo, ND 58078 Fax 701.282.8131  
 WWW.GROUSER.COM

TITLE: Torque Arm for Front Hitches

Date: 2-16-2017

DWG. NO.: 19719-A