



FH-400 John Deere 8020 w/o ILS

Undercarriage Installation Instructions

Caution:

- Always use precaution when working around any equipment.
- Always wear safety glasses.
- Follow tractor manufacture's safety guidelines when installing this product.
 1. Read all instructions prior to installation.
 2. Remove weights and weight bracket from front of tractor if necessary.
 3. Position the undercarriage (U/C) under the tractor and center with the frame of the tractor.
 4. Lift the U/C until the holes on the tractor line up with the U/C holes.
 5. At the front of the tractor, use 4 - 20mm x 70mm bolts (PN: 16-1876) with a 3/4" washer (PN: 57-20747) on each bolt to attach the U/C to the front of the tractor. See attached diagram for clarification.
 6. Raise rear of undercarriage until holes on the tractor line up with the U/C holes.
Be sure that the push blocks are tight against bolt heads at rear of U/C.
 7. Attach rear of U/C to tractor with 4 - 20mm x 50mm bolts (PN: 16-1878) with a 3/4" washer (PN: 57-20747) on each bolt.
 8. Attach the right rail (PN: 46-3282) to the right side of the undercarriage with 6 - 3/4" bolts (PN: 16-20219), 12 - 3/4" flat washers (PN: 57-20747), and 6 - 3/4" center lock nuts (PN: 70-20607). See attached diagram for clarification.
 9. Attach the left rail (PN: 46-3283) to the left side of the undercarriage with 6 - 3/4" bolts (PN: 16-20219), 12 - 3/4" flat washers (PN: 57-20747), and 6 - 3/4" center lock nuts (PN: 70-20607). See attached diagram for clarification.
 10. Start 6 - 5/8" x 3-1/2" bolts (PN: 16-20194) with a 5/8" flat washer (PN: 57-20746) on each bolt through the top holes of the left and right rail and the tractor frame. See attached diagram for clarification.
 11. Once all bolts are installed, torque all 20mm bolts to 432 ft-lbs., all 3/4" bolts to 257 ft-lbs., and all 5/8" bolts to 154 ft-lbs.
 12. After first 8 hours of use, re-torque all bolts.
 13. Check all fasteners regularly to ensure proper operation of equipment.

Parts only shown on left side. Right side is identical.

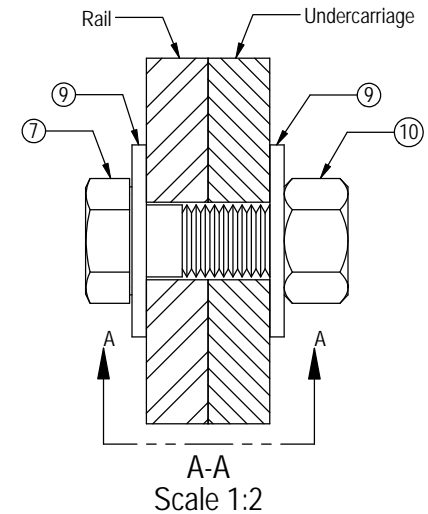
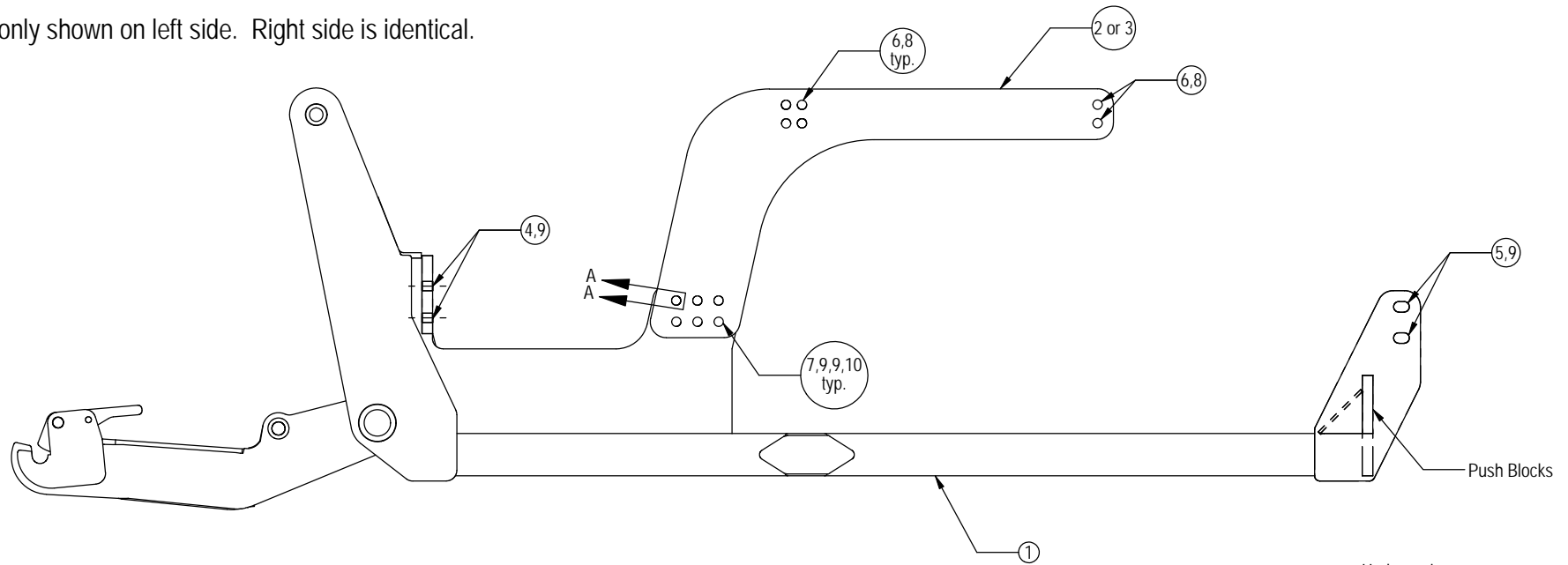

Item No.	Qty.	Part No.	Description
1	1	54-3278	FH-400 UC JD 8020 Series Rev1
2	1	46-3646	FH-400 JD 8020 Side Plate Rail Left Weld
3	1	46-3647	FH-400 JD 8020 Side Plate Rail Right Weld
4	4	16-1876	20mm x 2.5mm x 70mm Metric Hex Bolt Gr 10.9
5	4	16-1878	20mm x 2.5mm x 50mm Metric Hex Bolt Gr 10.9
6	12	16-20194	5/8" x 3-1/2" Hex Bolt Gr 5 NC
7	12	16-20219	3/4" x 2-1/4" Hex Bolt Gr 5 NC
8	12	57-20746	5/8" Flat Washer
9	32	57-20747	3/4" Flat Washer
10	12	70-20607	3/4" Hex Center Lock Nut Gr 5 NC



GROUSER PRODUCTS INC.

755 2nd Ave NW Phone 701.282.7710
West Fargo, ND 58078 Fax 701.282.8131
WWW.GROUSER.COM

TITLE FH-400 UC JD 8020 w/o ILS		DWG. NO. 2401-A
Date: 11/5/2005	Scale: 1:16	Sheet: 1