



# FH-400 Massey 8200 & Cat 600A Series

## Undercarriage Installation Instructions

### **Caution:**

- Always use precaution when working around any equipment.
  - Always wear safety glasses.
  - Follow tractor manufacturer's safety guidelines when installing this product.
1. Read all instructions prior to installation.
  2. Remove weights and mounting bracket from front of tractor. Bolts will be reused for mounting the undercarriage (U/C).
  3. Position the U/C under the tractor and center with the frame of the tractor.
  4. Lift the U/C until the holes on the U/C line up with the front weight bracket mounting holes.
  5. At the front of the tractor, use the weight mount bracket bolts to attach the U/C to the front of the tractor.
  6. Attach the right and left rails (PN: 46-3393) to the sides of the tractor frame with 2 - 20mm bolts (PN: 16-1876) and 2 - 3/4" flat washers (PN: 57-20747) for each side rail. See attached diagram for clarification.
  7. Attach the left and right rails to the left side of the U/C with 3 - 1" bolts (PN: 16-20558), 6 - 1" heavy duty flat washers (PN: 57-20819), and 3 - 1" nuts (PN: 70-20599). See attached diagram for clarification.
  8. Once all bolts are installed, torque the front bolts to 432 ft-lbs., all 20mm bolts to 432 ft-lbs., and all 1" bolts to 903 ft-lbs.
  9. Adjust drawbar to the furthest forward hole.
  10. Install push pole (PN: 17-3396) with 1" pin (PN: 43-3472), 1" flat washer (PN: 57-20749), and a pin clip (PN: 43-7767). Place shims (PN: 44-7221) at end of push pole until it is tight against the drawbar.
  11. After first 8 hours of use, re-torque all bolts.
  12. Check all fasteners regularly to ensure proper operation of equipment.

THE INFORMATION CONTAINED IN THIS DRAWING IS THE SOLE PROPERTY OF GROUSER PRODUCTS INC ANY REPRODUCTION IN PART OR WHOLE WITHOUT THE WRITTEN PERMISSION OF GROUSER PRODUCTS INC IS PROHIBITED.

REVISIONS:

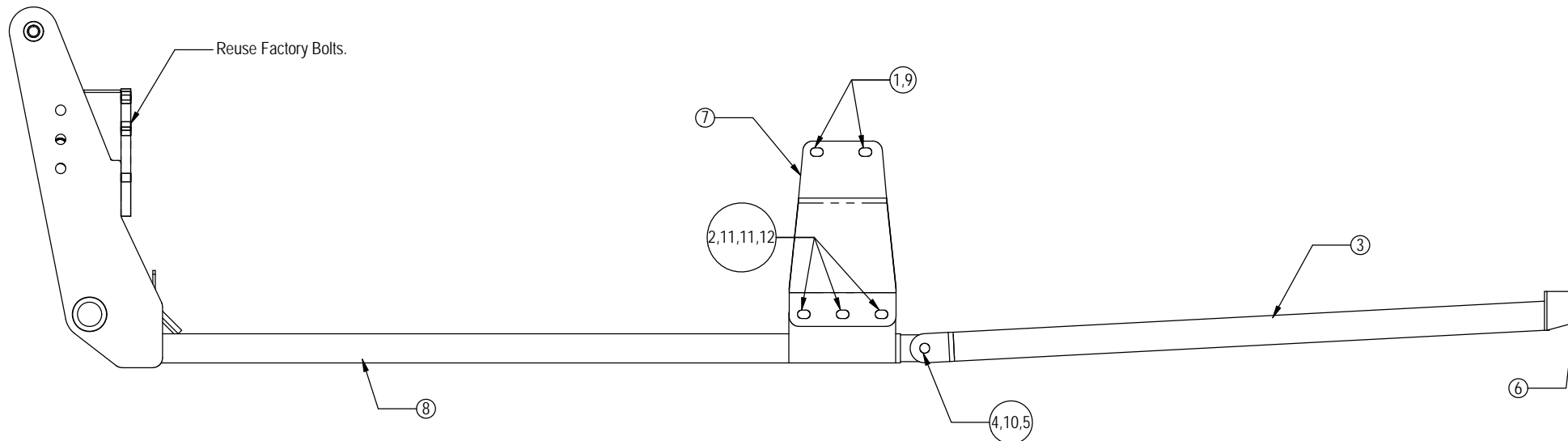

Item No.	Qty.	Part No.	Description
1	4	16-1876	20mm x 2.5mm x 70mm Metric Hex Bolt Gr 10.9
2	6	16-20558	1" x 2" Hex Bolt Gr 8 NC
3	1	17-3396	FH-400 Massey 8200, Agco DT, Cat 600A/B Series - Push Pole (64.34")
4	1	43-3472	1" x 3.12" Welded Pin w/ Holes & Washer
5	1	43-7767	Hitch Pin Clip
6	8	44-7221	FH-400 Push Pole Shim 1/8"
7	2	46-3393	FH-400 Massey 8200, Cat 600 Series - Rail
8	1	54-3394	FH-400 UC Massey 8200, Agco DT, Agco 9700, Cat 600A/B Series
9	4	57-20747	3/4" Flat Washer
10	1	57-20749	1" Flat Washer
11	12	57-20819	1" Flat Washer Heavy Duty Gr 8 (USS)
12	6	70-20599	1" Hex Nut Gr 8 NC



**GROUSER PRODUCTS INC.**

755 2nd Ave NW Phone 701.282.7710  
 West Fargo, ND 58078 Fax 701.282.8131  
 WWW.GROUSER.COM

TITLE FH-400 Massey 8200 and  
 Cat 600A Series UC Assy.

DWG. NO.  
**2412**

Date:  
 2-25-2008

Scale:  
 1:16

Sheet:  
 1