



FH-400 Case STX Non-AccuSteer Kneeler

Undercarriage Installation Instructions

Caution:

- Always use precaution when working around any equipment.
- Always wear safety glasses.
- Follow tractor manufacturer's safety guidelines when installing this product.
 1. Read all instructions prior to installation.
 2. Remove existing toolboxes and tow cable holder if equipped.
 3. Attach the spacer to the front side of the front axle with 4 - 20mm x 50mm bolts (PN: 16-1878) and a 3/4" flat washer (PN: 57-20747) on each bolt. Finger tighten the bolts.
 4. Position the undercarriage (U/C) under the tractor and center with the frame of the tractor.
 5. Raise the front of the U/C to within 1/2" from the frame of the tractor.
 6. Start 4 - 20mm x 90mm bolts (PN: 16-1510) with a large washer (PN: 57-8836) on each bolt into the bottom vertical slots at the front of the U/C. Tighten the bolts until the washers contact the U/C. See attached diagram for clarification.
 7. Align the rear of U/C to the spacer.
 8. Attach the U/C to the spacer with 4 - 7/8" x 2-1/2" bolts (PN: 16-20540), two 7/8" heavy duty flat washers (PN: 57-20818), and a 7/8" nut (PN: 70-20598) on each bolt.
 9. Torque the 20mm x 50mm spacer bolts to 432 ft-lbs.
 10. Proceed with torqueing the vertical 20mm x 90mm bolts to 432 ft-lbs. and the 7/8" bolts to 600 ft-lbs.
 11. Use the side frame holes as guides and drill 6 - 1" holes through the side of the tractor frame.

Caution: When drilling, be aware of all parts behind the material being drilled so that you do not mistakenly hit or puncture components on engine side of tractor frame.
 12. Install 6 - 1" x 3" bolts (PN: 16-20562) with a 1" heavy washer (PN: 57-3682) in the previously drilled holes. See attached diagram for clarification.
 13. After the 6 - 1" bolts are through the tractor frame, attach with a 1" heavy washer (PN: 57-3682) and 1" nut (PN: 70-20599) on each bolt.
 14. Torque all 1" bolts to 903 ft-lbs.
 15. After first 8 hours of use, re-torque all bolts.
 16. Check all fasteners regularly to ensure proper operation of equipment.

THE INFORMATION CONTAINED IN THIS DRAWING IS THE SOLE PROPERTY OF GROUSER PRODUCTS INC ANY REPRODUCTION IN PART OR WHOLE WITHOUT THE WRITTEN PERMISSION OF GROUSER PRODUCTS INC IS PROHIBITED.

REVISIONS: 10/11/2005 - removed 12 - 1" flat washers (PN: 57-20749)

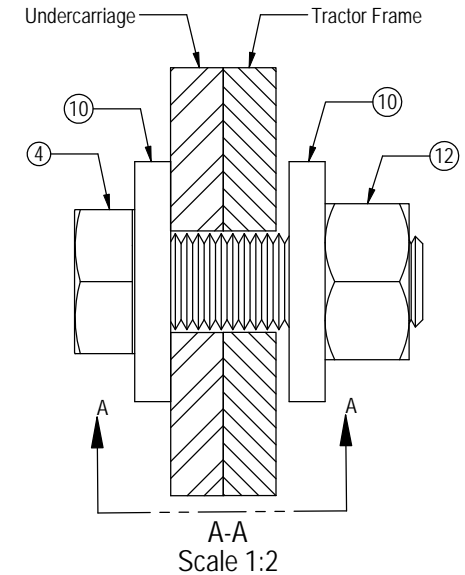
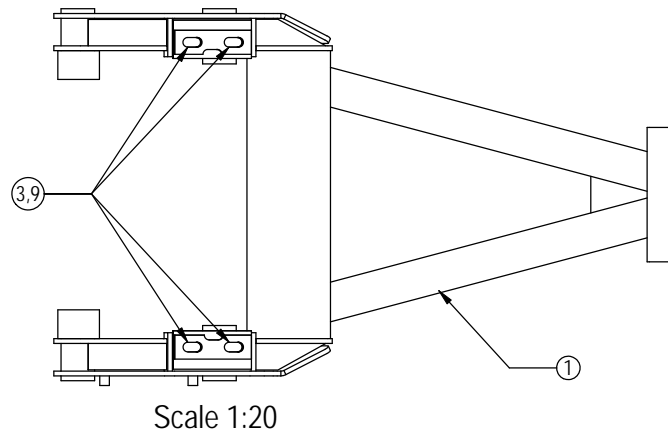
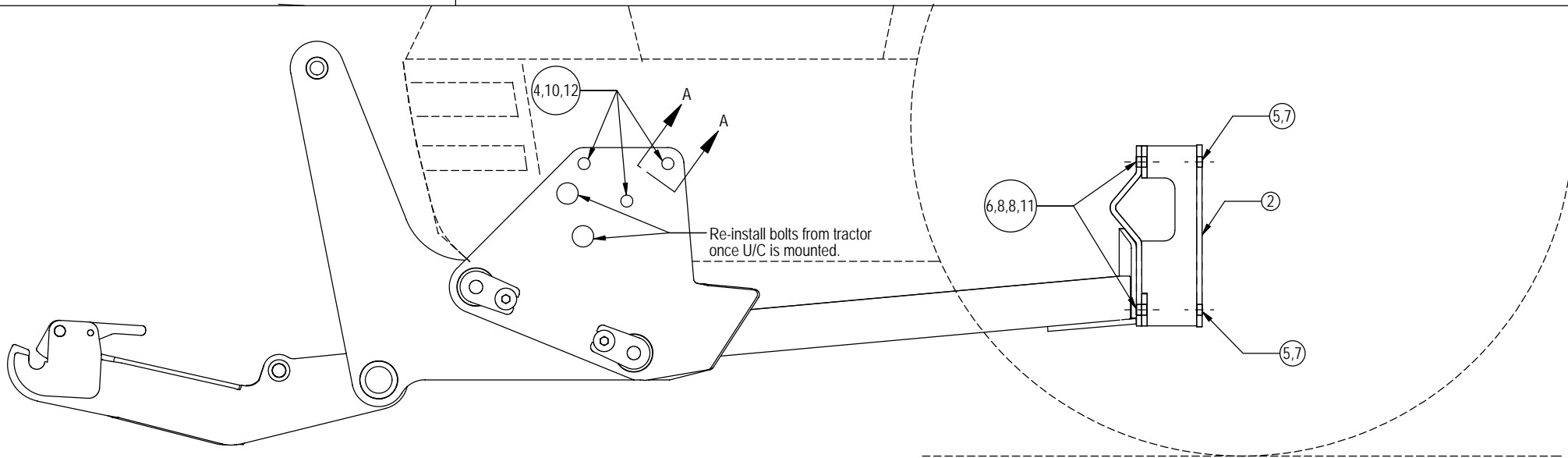

ITEM NO.	QTY	PART NO.	DESCRIPTION
1	1	54-9622	FH-400 UC Case STX Accu-Steer
2	1	54-1717	PL-41 UC Case STX 275,325 Spacer
3	4	16-1510	20mm x 2.5mm x 90mm Metric Hex Bolt Gr 10.9
4	6	16-20562	1" x 3" Hex Bolt Gr 8 NC
5	4	16-1878	20mm x 2.5mm x 50mm Metric Hex Bolt Gr 10.9
6	4	16-20540	7/8" x 2-1/2" Hex Bolt Gr 8 NC
7	4	57-20747	3/4" Flat Washer
8	8	57-20818	7/8" Flat Washer Heavy Duty Gr 8 (USS)
9	4	57-8836	0.91" ID x 2.50" OD x 0.50" Heavy Washer CZ Plated
10	12	57-3682	1.00" ID x 2.50" OD x 0.375" Thick Washer CZ Plated
11	4	70-20598	7/8" Hex Nut Gr 8 NC
12	6	70-20599	1" Hex Nut Gr 8 NC

GROUSER PRODUCTS INC.

755 2nd Ave NW Phone 701.282.7710
 West Fargo, ND 58078 Fax 701.282.8131
 WWW.GROUSER.COM

TITLE	STX Non Accusteer Kneeler Mounting	DWG. NO. 2453
Date: 3/25/08	Scale: 1:14	Sheet: 1