

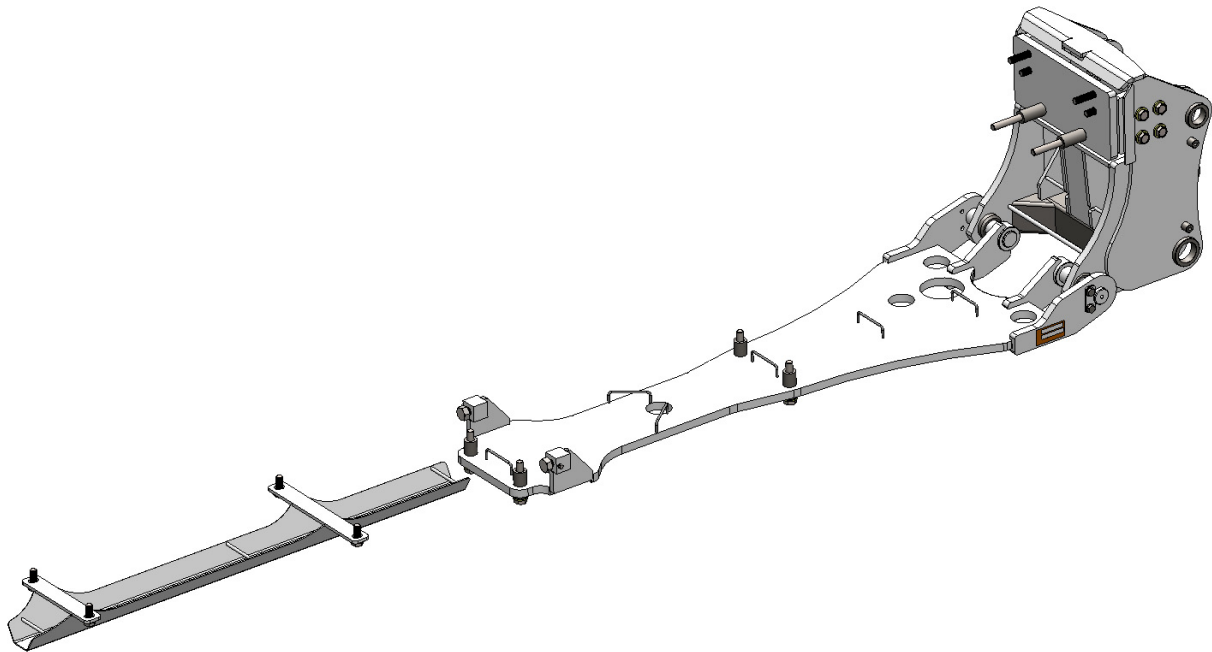

Fendt 1000 Vario & Challenger 1000

Undercarriage Installation Instructions



For Models Without Factory Three Point Linkage:

Fendt 1000 Vario: 1038, 1042, 1046, 1050

Challenger 1000: 1038, 1042, 1046, 1050

Purchase Date
Serial Number
Model Number
Tractor Model
Dealer

To The Owner

This manual contains information concerning the installation of the undercarriage. You have purchased dependable, long lasting equipment, but only by proper care and operation can you expect to receive the performance and long service built into our products. Please have all operators read this manual carefully and keep the manual available for ready reference. If you have any questions or concerns, contact Grouser Products.

Caution:

- Always use caution when working around any equipment.
- Always wear safety glasses.
- Follow tractor manufacturer's safety guidelines when installing this product.
- Use paint where necessary to prevent rust.
- Do not modify or permit anyone else to modify or alter the equipment and its components without first consulting Grouser Products.

Note:

- When installing hardware, only finger tighten until all hardware is in place.
- A full diagram of the assembly with the full list of parts is on pages 6-7.
- Tractor frame not shown in some diagrams for clarity.
- Unstrap and remove any components that are attached for shipping.
- Read all instructions prior to performing installation.
- Grouser FH-440 lift system needs to be in the lowered position to torque the front bolts in Step #15.

Pre-Installation

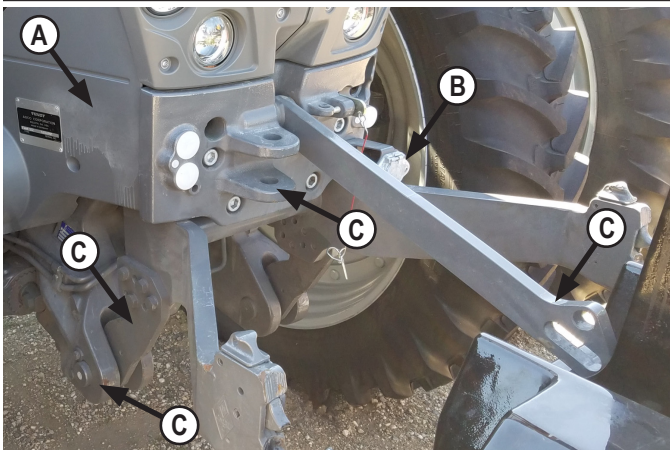

1. Remove the side shields (A).
2. Unplug and remove the electrical socket (B) from the front of the tractor. It will be reinstalled in Step #22. The bracket can stay on the front plate.
3. Remove the front weights, front rigid arms and brackets, bottom pins and retaining hardware, the top link and the front plate (C).

NOTE: The threaded hole on the bottom pin is for installing a 10mm x 1.5mm bolt to aid in pulling out the pin.

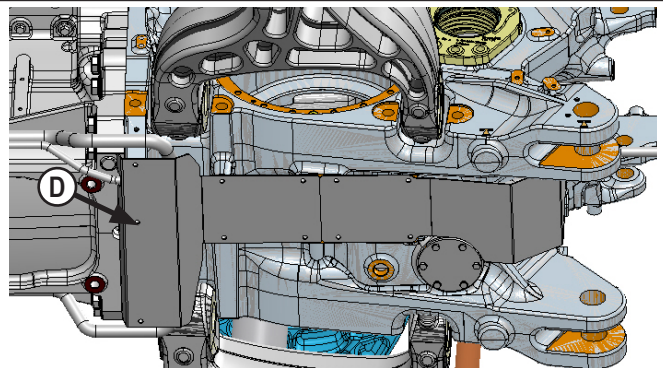

4. Remove the rear shield from underneath the front of the tractor (D).

Undercarriage Installation

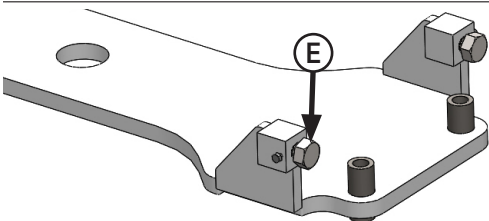

5. Install 2 - 1" x 2" bolts in the threaded blocks at the rear of the support (E). Turn the bolts all the way in for installation. The bolts will be adjusted in Step #17.

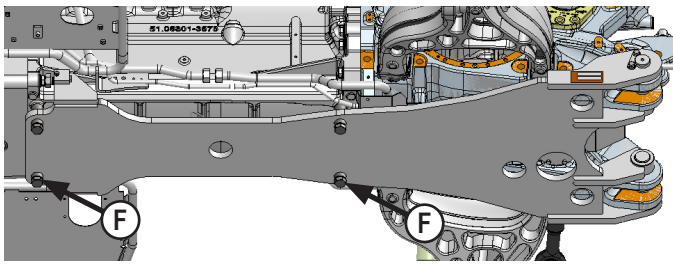

6. Center the front support under the tractor.
7. Raise the front support until its ears line up with the ears on the tractor frame.
8. Install 4 - 20mm x 120mm bolts with 4 - .81" ID washers through the vertical standoffs and into the bottom of the engine casting (F).

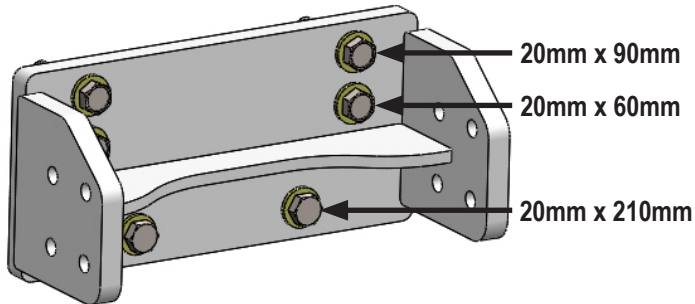

9. Install 2 - 20mm x 90mm bolts with 2 - .81" ID washers through the top holes in the front master plate bracket and tractor front nose casting.
10. Install 2 - 20mm x 60mm bolts with 2 - .81" ID washers through the second row of holes in the front master plate bracket and tractor front nose casting.
11. Install 2 - 20mm x 210mm bolts, 2 - .81" ID washers, and 2 - standoffs through the bottom holes in the front master plate bracket and tractor front nose casting. The standoffs fit between the front master plate bracket and the tractor front nose casting.

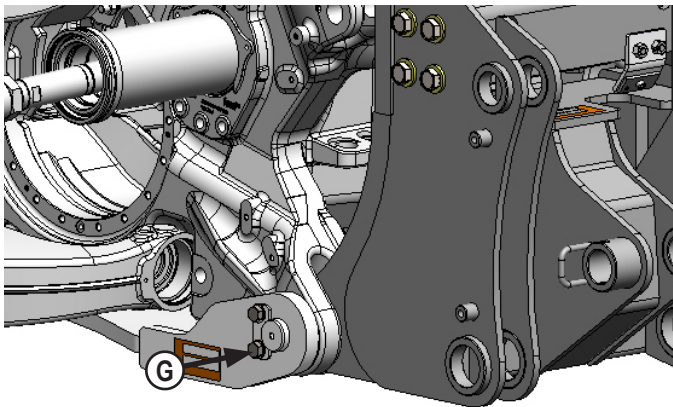

12. Install the new pins through the outer front ears of the front support, tractor frame and the undercarriage mount. Secure with 4 - 14mm x 25mm bolts, 4 - 14mm flat washers, and 2 - pin retainer plates (G).

NOTE: The front support and lift system are not shown for clarity.

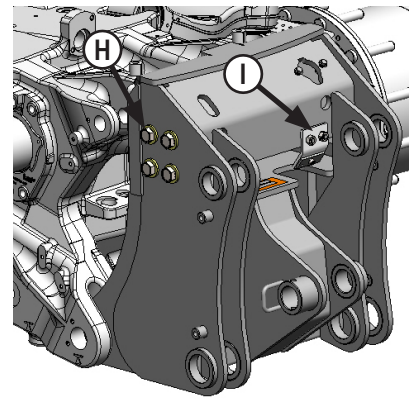

13. Raise the front undercarriage mount and install 4 - 20mm x 50mm bolts with 4 - .81" ID washers through the side holes on the undercarriage mount and the front master plate bracket (H).
14. Remove the hose clamp bracket (I) from the front of the undercarriage mount to gain access for torquing the bottom front bolts.
15. Torque the front 20mm bolts to 432 ft-lbs.
16. Torque the side 20mm bolts to 432 ft-lbs.

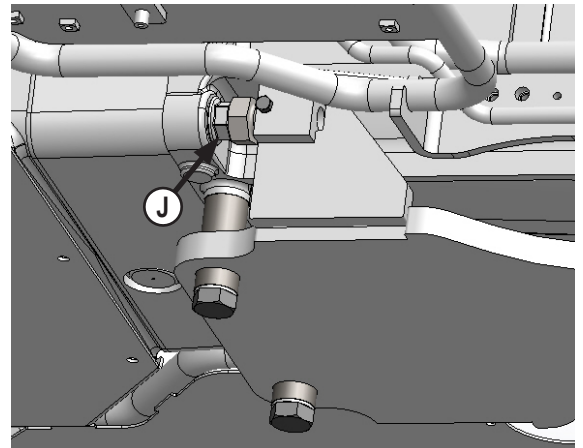

17. Evenly unscrew the 1" bolts at the rear of the front support until they are tight against the engine casting bolt heads (J). Torque the 1" bolts to 90-95 ft-lbs.
18. Install 2 - 5/16" x 3/4" bolts into the blocks at the rear of the front support to lock the 1" x 2" bolts. Torque the 5/16" bolts to 19 ft-lbs.
19. Torque the vertical 20mm bolts to 432 ft-lbs.
20. Torque the 14mm retaining bolts for the ear pins at the front of the support to 103 ft-lbs.
21. Reattach the hose clamp bracket that was removed in Step #14.

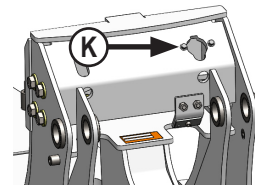

22. Reattach the front electrical socket with 2 - 5/16" x 1-1/4" bolts, 2 - 1/4" washers, and 2 - 5/16" nyloc nuts to the top of the undercarriage mount (K).
23. Reconnect the electrical socket wire connection into the tractor side wire harness.

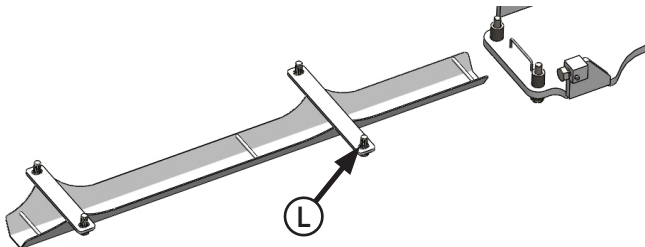

24. Position the hose channel under the tractor behind the front support (L).

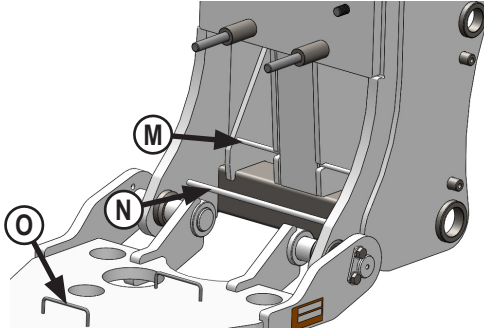

25. Route the hoses from the front of the undercarriage under the first set of bars (M) and then over the bottom bar (N) on the undercarriage.

26. Continue to route the hoses through the hose loops on the front support (O).

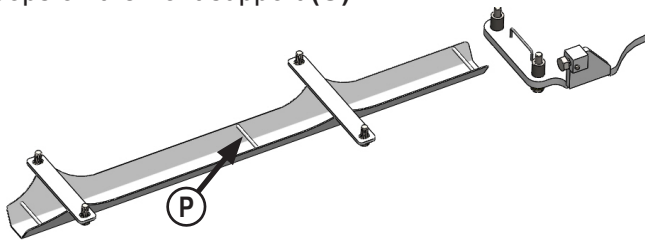

27. Route the hoses through the hose channel. Keep the hoses below the bars on the hose channel (P).

28. Raise the hose channel and attach to the tractor with 4 - 20mm x 50mm bolts and 4 - 0.81" ID washers.

29. Torque the 20mm bolts to 432 ft-lbs.

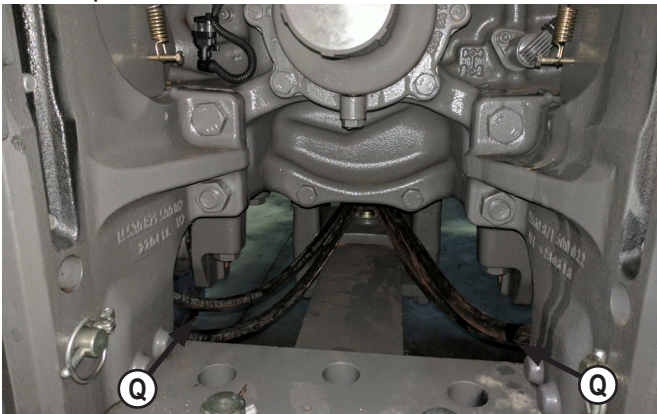

30. Route the hoses to the back of the tractor. Stay above the drawbar and away from the PTO (Q).

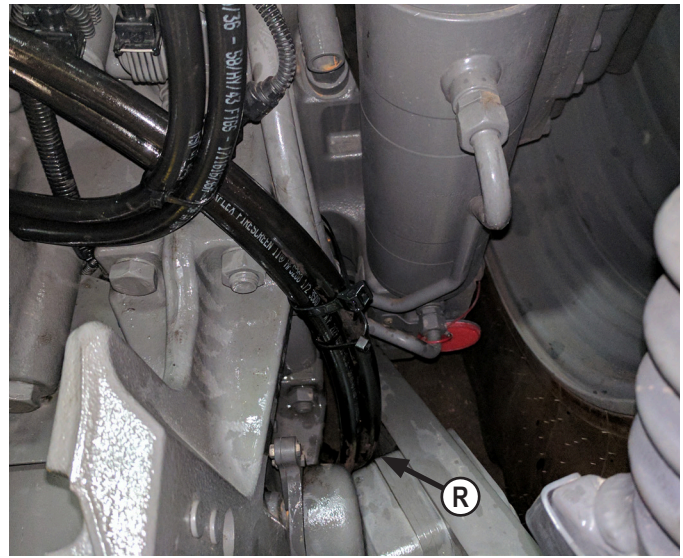

31. Route the hoses up through the opening between the slide rails and the 3-point lower arm on each side (R). Quantity of hoses can vary depending on which blade system is installed.

32. Protect the hoses around sharp corners and moving objects. Use zip ties to secure the hoses in place.

33. Plug the hoses into the open SCV's at the rear of the tractor.

Warning: Fully oscillate the blade angle, tilt, steering, suspension and rear 3-point to check for adequate clearance.

If necessary, purchase and install steering stops from your local dealership to avoid collision and subsequent damage. The minimum clearance between the front support pin and the tire should be about 1".

The minimum clearance between any part on the blade and the front tires when the blade is fully angled, should be 3". If more clearance is necessary between the blade and front tires, call Grouser Products to purchase the extension on page #5.

Maintenance

1. After first 8 hours of use, re-torque all bolts. Check to make sure the 1" bolts at the back of the front support are tight against the bolt heads as shown in Step #17.
2. Check all fasteners regularly to ensure proper operation of equipment.
3. Inspect all equipment for existing or potential damages every 10 hours or less.

Additional Extension

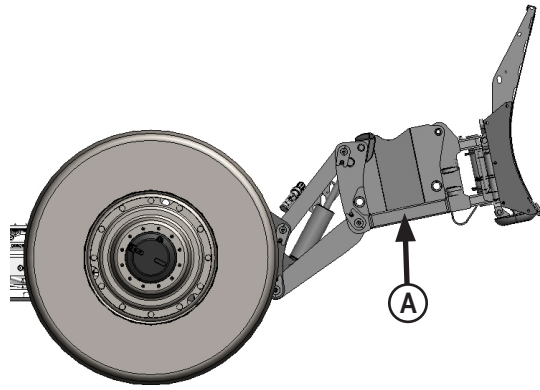

1. An additional extension (A) may be necessary if your tractor is equipped with front duals. Tire size and row spacing will determine if your system will require the extension.
2. All 650 and 710 dual front tire configurations require the extension.
3. Call Grouser with tire information to discuss if the extension is necessary for your system.

NOTE: Grouser Products is not responsible for damage to tires or blade if the extension is not installed.

Extension Installation

1. If blade system is on the FH-440 lift system, disconnect the blade system from the FH-440 lift system.
2. Center and raise the extension until the top pins are fully engaged in the top hooks of the blade system.
3. Insert the lock out pins to attach the extension to the blade system.
4. Secure both lock out pins with 1/2" x 3-1/2" bolts and 1/2" lock nuts.
5. Position and attach the adapter stand in the down position as shown below.
6. Secure the hoses from the blade system to the left side of the extension with a cordura strap, 3/8" flat washer and 3/8" nyloc nut. Verify that all hoses have some slack to move when operating all of the blade functions.
7. Connect the extension with blade system to the FH-440 lift system.
8. Shut off the tractor engine and set the parking brake.
9. Pull the quick attach lock handle and lift the locking latch to lock the handle in place.
10. Clean hydraulic couplers and connect hydraulic couplers on the top arm. Refer to AG240 Dozer Owner's Manual and Parts Book for proper location of all functions.
11. Start tractor engine and raise lift system until the adapter stand is off the ground.
12. Shut off tractor engine and set parking brake.
13. Remove hitch pin with chain, rotate stand up and reattach with the pin.

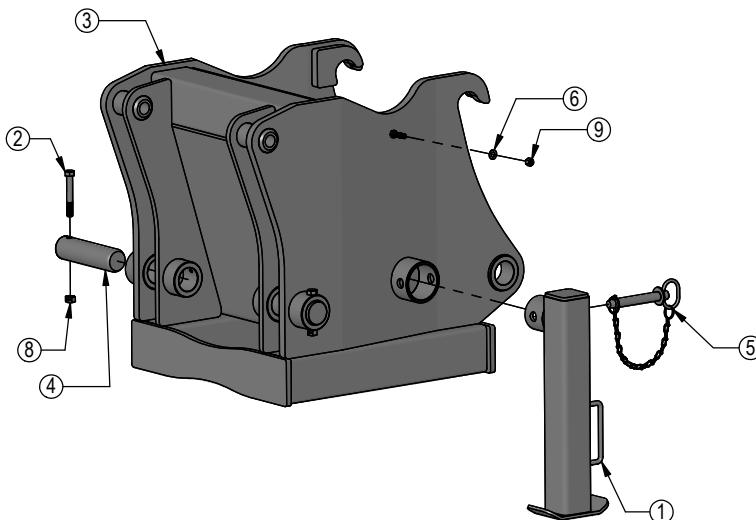

ITEM NO.	QTY.	PART NO.	DESCRIPTION
1	1	11-40610R1	440 To 240 Adapter Stand
2	2	16-20134	1/2" x 3-1/2" Hex Bolt Gr. 5 NC
3	1	32-40285R2	FH440 To 240 Extension
4	2	43-16923R2	Lock Out Pin
5	1	43-40453	Hitch Pin with Chain
6	1	57-20742	3/8" Flat Washer
7*	1	59-16899-6	Heavy Duty Velcro Strap
8	2	70-20604	1/2" Center Lock Hex Nut
9	1	70-20612	3/8" Nyloc Nut

* Part Not Shown

ITEM NO.	QTY.	PART NO.	DESCRIPTION
1	4	16-1415025	14mm x 1.50mm x 25mm Hex Bolt Gr 10.9
2	2	16-1510	20mm x 2.5mm x 90mm Hex Bolt
3	12	16-1878	20mm x 2.5mm x 50mm Gr. 10.9 Hex Bolt
4	2	16-20032	5/16" x 3/4" Hex Bolt Gr 5 NC
5	2	16-20035	5/16" x 1-1/4 " Hex Bolt Gr 5 NC
6	2	16-20250210	20mm x 2.50mm x 210mm Hex Bolt Gr 10.9
7	2	16-20558	1" x 2" Hex Bolt Gr. 8 NC
8	2	16-2487	20mm x 2.5mm x 60mm Hex Bolt Gr. 10.9
9	4	16-2489	20mm x 2.5mm x 120mm Hex Bolt Gr 10.9
10	1	17-40310R1	Mount Weld
11	1	18-40280	Hose Clamp Bracket
12	1	18-40330	Hose Channel
13	2	19-40281	Stand Off
14	2	27-18887	Grouser Name Plate Decal
15	2	27-9506	Serial Tag Decal
16	2	43-19795R1	Pin
17	2	44-19789R1	Pin Retainer Plate (14mm)
18	1	44-40325	Master Plate Weld
19	1	54-19790R3	Front Support Weld
20	22	57-19088	1.6875" OD x .813" ID x .187" HD Washer YZ
21	2	57-20740	1/4" Flat Washer
22	4	57-20824	14mm Flat Washer
23	2	70-20604	1/2" Center Lock Hex Nut
24	2	70-20611	5/16" Nyloc Hex Nut Gr 5 NC

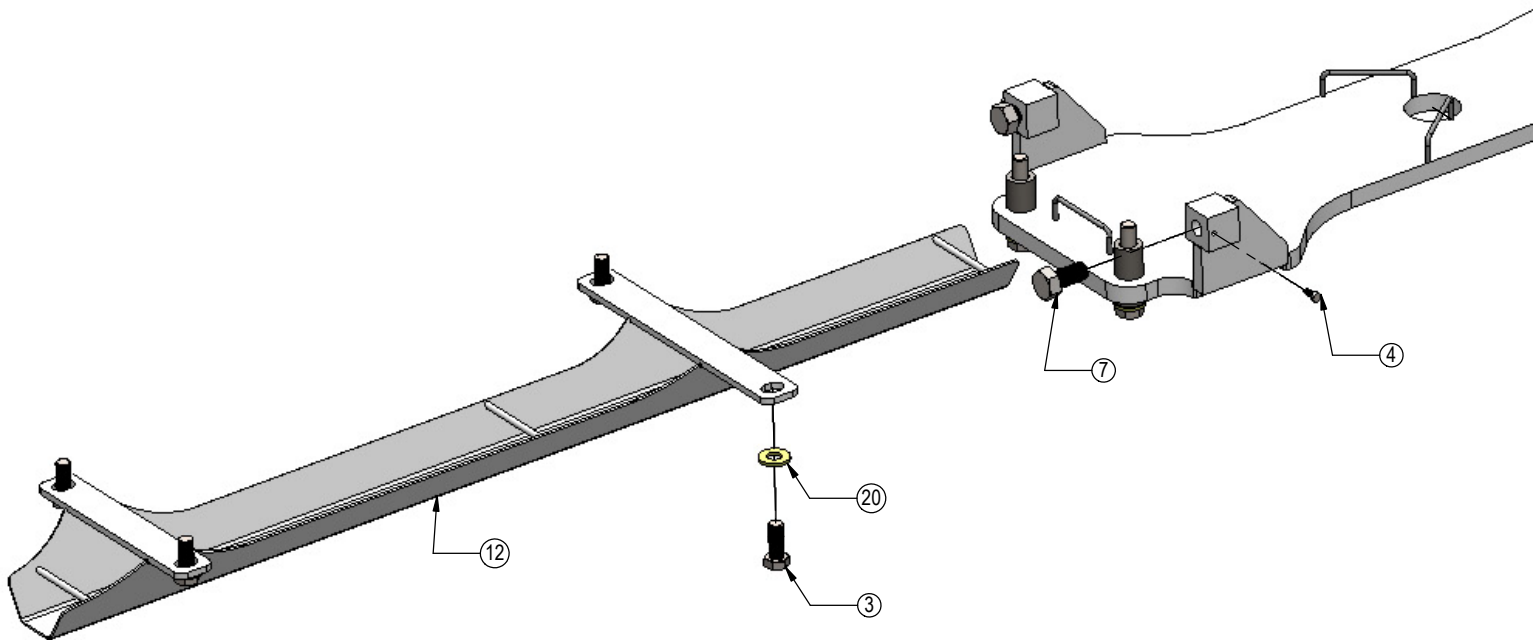

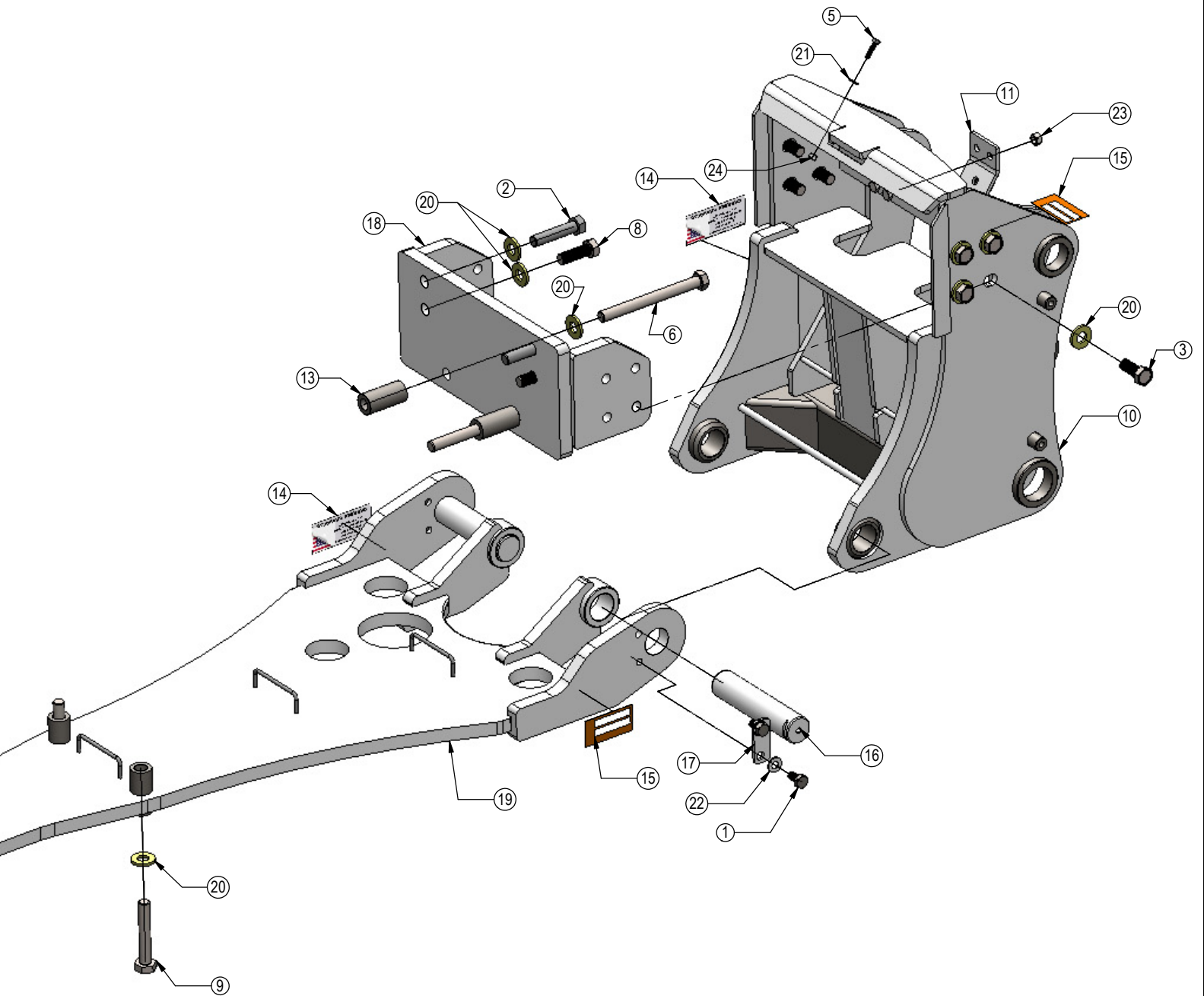

Contact Us

As always, if you have any questions about your undercarriage or other products made by Grouser, feel free to contact us.

Grouser Products

755 2nd Ave NW - West Fargo, ND 58078

Phone: 1-800-747-6182

Fax: 1-701-282-8131

E-mail: grouser@grouser.com

Website: www.grouser.com



Improvements

Grouser Products Inc. is continually striving to improve its products. We reserve the right to change prices, specification, or equipment at any time without notice. We also reserve the right to make improvements or changes when it becomes practical and possible to do so without incurring any obligation to make changes or additions to the equipment sold previously.

Warranty

Grouser Products warrants to the original purchaser of each item that the product be free from defects in material and workmanship under normal use and service for a period of two years from date of original retail delivery. If such equipment is found to be defective within two years, it is the obligation of Grouser Products under this warranty to repair or replace (exclusive of the cost of labor and transportation), any equipment or parts, in the judgment of Grouser Products to be defective in material or workmanship.

All equipment or parts claimed to be defective in material or workmanship must be made available for inspection at the place of business of a dealer authorized to handle the equipment covered by this warranty, or, upon request by Grouser Products, shipped to the Grouser Products factory in West Fargo, North Dakota. Grouser Products shall have no obligation to bear the cost of labor or transportation in connection with replacement or repair of any such defective parts in the setup process.

This warranty covers only defects in material and workmanship. It does not cover depreciation or damage caused by normal wear, accident, improper assembly, improper adjustments, improper maintenance including lack of proper lubrication, or improper use. Therefore, Grouser Products liability under this warranty shall not be effective or actionable unless the equipment is assembled, maintained and operated in accordance with the operating instructions accompanying the equipment. Grouser Products shall have no liability if the equipment has been altered or reworked without the written authorization of Grouser Products.

Grouser Products' parts, which are furnished under this warranty and properly installed, shall be warranted to the same extent as the original parts under this warranty if, and only if, such parts are found to be defective within the original warranty period covering the original equipment.

