



Ag Pro Plus

Undercarriage Installation Instructions

Challenger MT900 B, C, E

For Models:

Challenger MT900 B, C, E: MT945, MT955,
MT965, MT975

Purchase Date
Serial Number
Model Number
Tractor Model
Dealer

To The Owner

This manual contains information concerning the installation of the undercarriage. You have purchased dependable, long lasting equipment, but only by proper care and operation can you expect to receive the performance and long service built into our products. Please read this manual carefully and keep the manual available for ready reference. If you have any questions or concerns, contact Grouser Products.

Caution:

- Always use caution when working around any equipment.
- Always wear safety glasses.
- Follow tractor manufacturer's safety guidelines when installing this product.
- Use paint where necessary to prevent rust.
- Do not modify or permit anyone else to modify or alter the equipment and its components without first consulting Grouser Products.

Note:

- Read all instructions prior to performing installation.
- When installing hardware, only finger tighten until all hardware is in place.
- A full diagram of the assembly with the full list of parts is on pages 6-7.
- Unstrap and remove any components that are attached for shipping.



Pre-Installation

1. If applicable, remove front weights and weight bracket from front of tractor.



2. If necessary, remove the switch guard from the left side of the tractor (A). Reinstall the hardware without the switch guard.

Undercarriage Installation

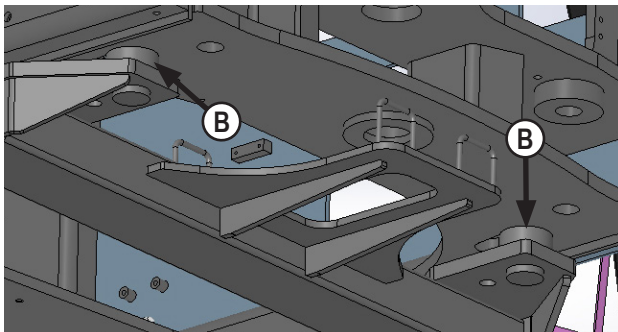

3. Position and center the undercarriage under the tractor.

NOTE: When lifting the undercarriage, watch for any potential pinching of hoses or any other components to prevent any damage.

4. Lift the undercarriage until the holes on the tractor line up with the holes on the undercarriage and the rear pins of the undercarriage are inserted into the rear bottom slots on the tractor (B).

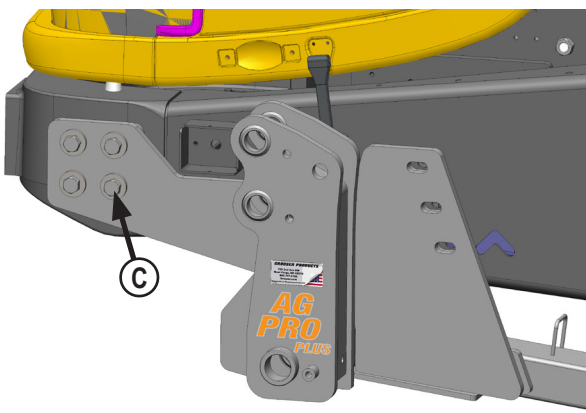

5. At the front of the tractor, install 8 - 24mm x 100mm bolts and 8 - 1" heavy washers (C).

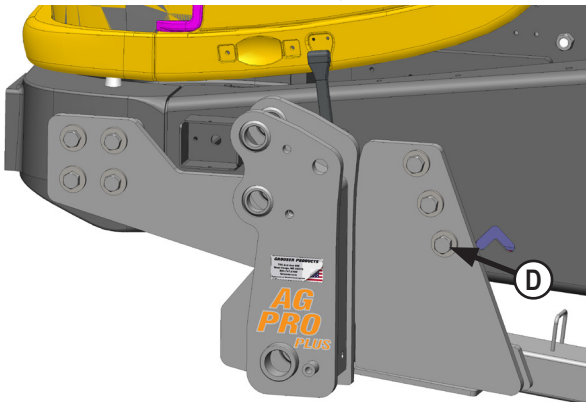

6. Install 6 - 1" x 4" bolts, 6 - 1" heavy washers, and 6 - 1" nuts in the rear holes of the side plates (D).

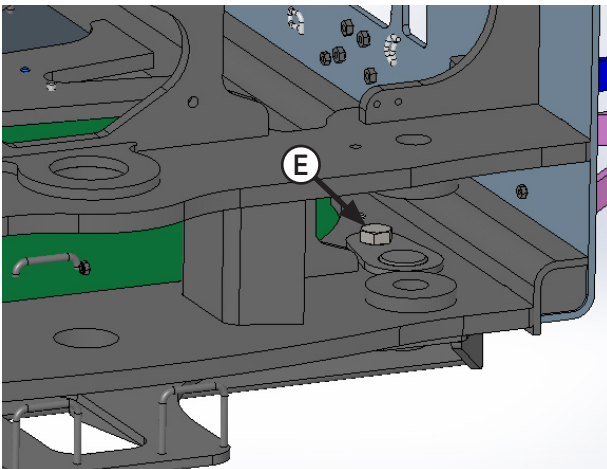

7. At the rear of the undercarriage, install 2 - Cat Tail Section washers, 2 - 1" x 5" bolts, and 2 - 1" nuts. Install the washer and the bolt from the top. Only hand tighten the nuts (E).

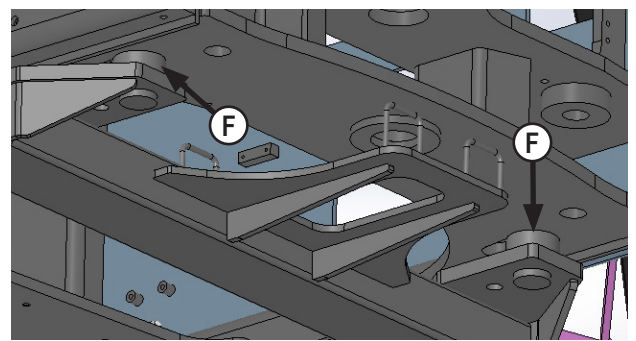

8. Verify that the undercarriage is centered on the tractor and push the undercarriage back until the rear pins of the undercarriage are tight against the rear bottom holes of the tractor frame (F).

9. Torque the rear 1" bolts to 903 ft-lbs (E).

10. Torque the front 24mm bolts to 909 ft-lbs (C).

11. Torque the side plate 1" bolts to 903 ft-lbs (D).

12. After first 8 hours of use, re-torque all bolts.

13. Check all fasteners regularly to ensure proper operation of equipment.

Assembling Lift Components

Refer to the Blade Owner's Manual & Parts Book for instructions on how to assemble the lift components.

Notes

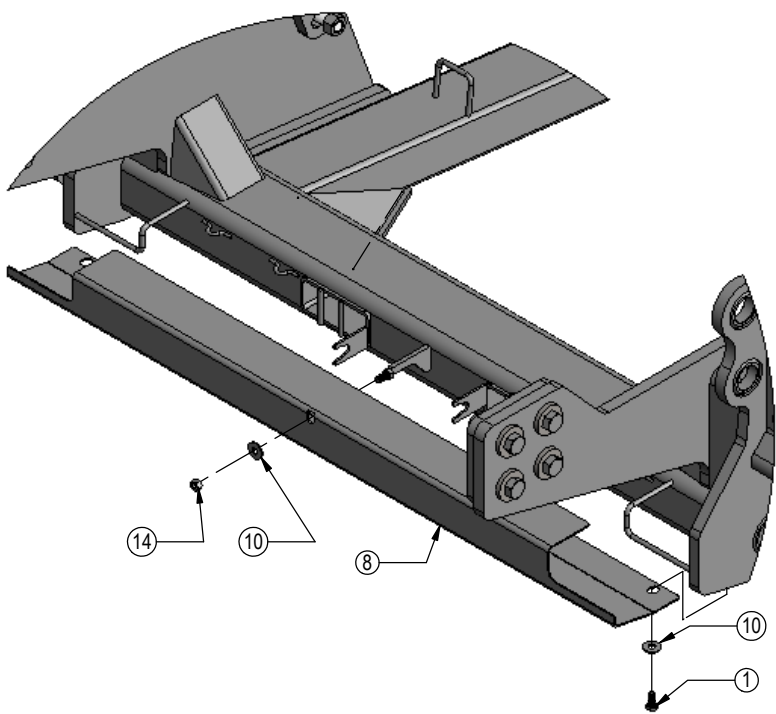
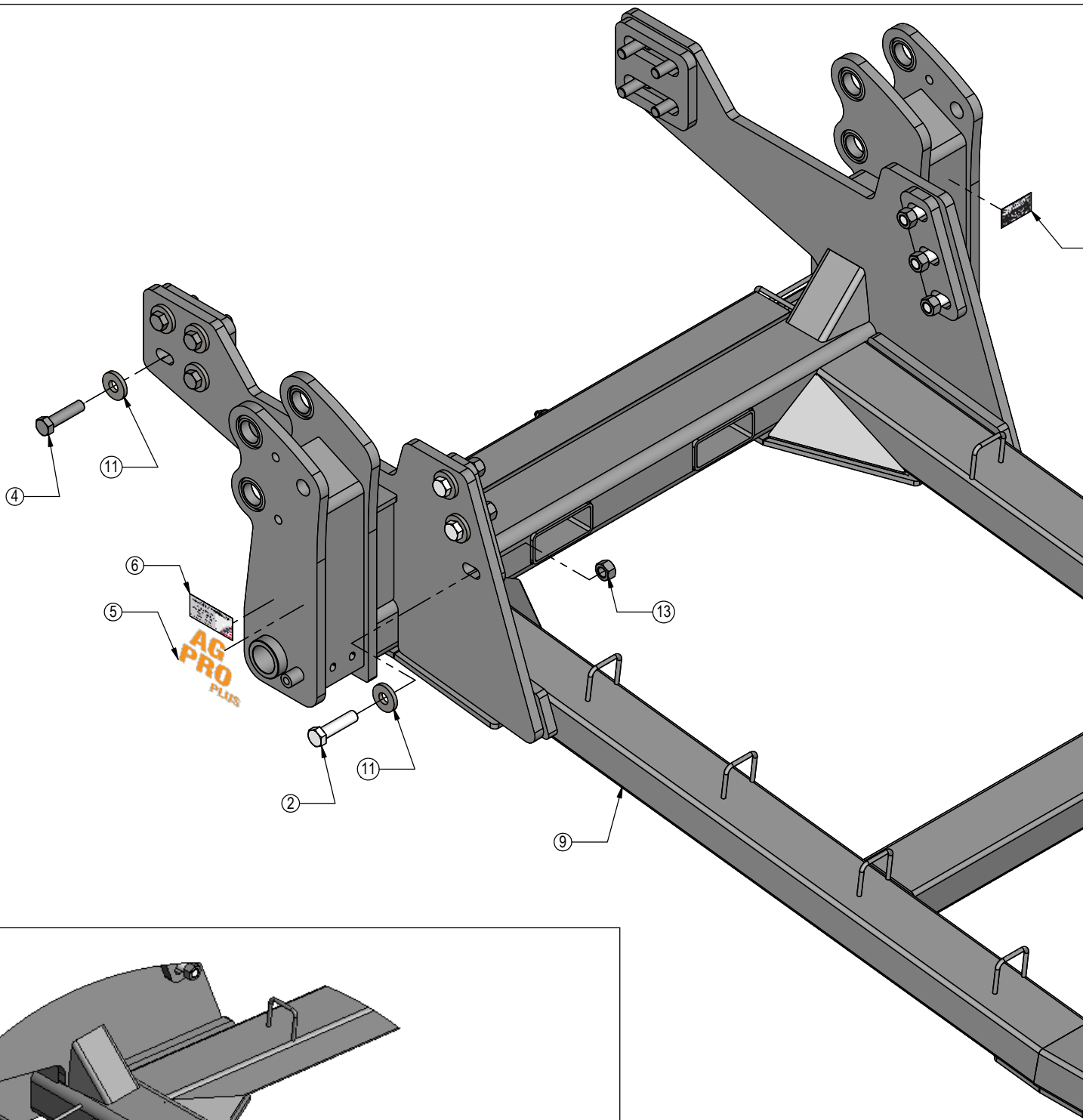

ITEM NO.	QTY.	PART NO.	DESCRIPTION
1	4	16-20124	1/2" x 1" Hex Bolt Gr.5 NC
2	6	16-20566	1" X 4" Hex Bolt Gr 8 NC
3	2	16-20568	1" x 5" Hex Bolt Gr.8 NC
4	8	16-2486	24mm x 3.0mm x 100mm Hex Bolt
5	2	27-18880	Ag Pro Plus Decal
6	1	27-18887	Grouser Name Plate Decal
7	1	NA	Grouser Dozer Metal Serial Tag
8	1	44-40504	Plate, Cover
9	1	54-40540	Undercarriage Weld
10	5	57-20744	1/2" Flat Washer
11	14	57-3682	1.00" ID x 2-1/2" OD x .375" Heavy Washer CZ Plated
12	2	57-5142	Washer
13	8	70-20599	1" Hex Nut Gr 8 NC
14	1	70-20604	1/2" Center Lock Hex Nut

7

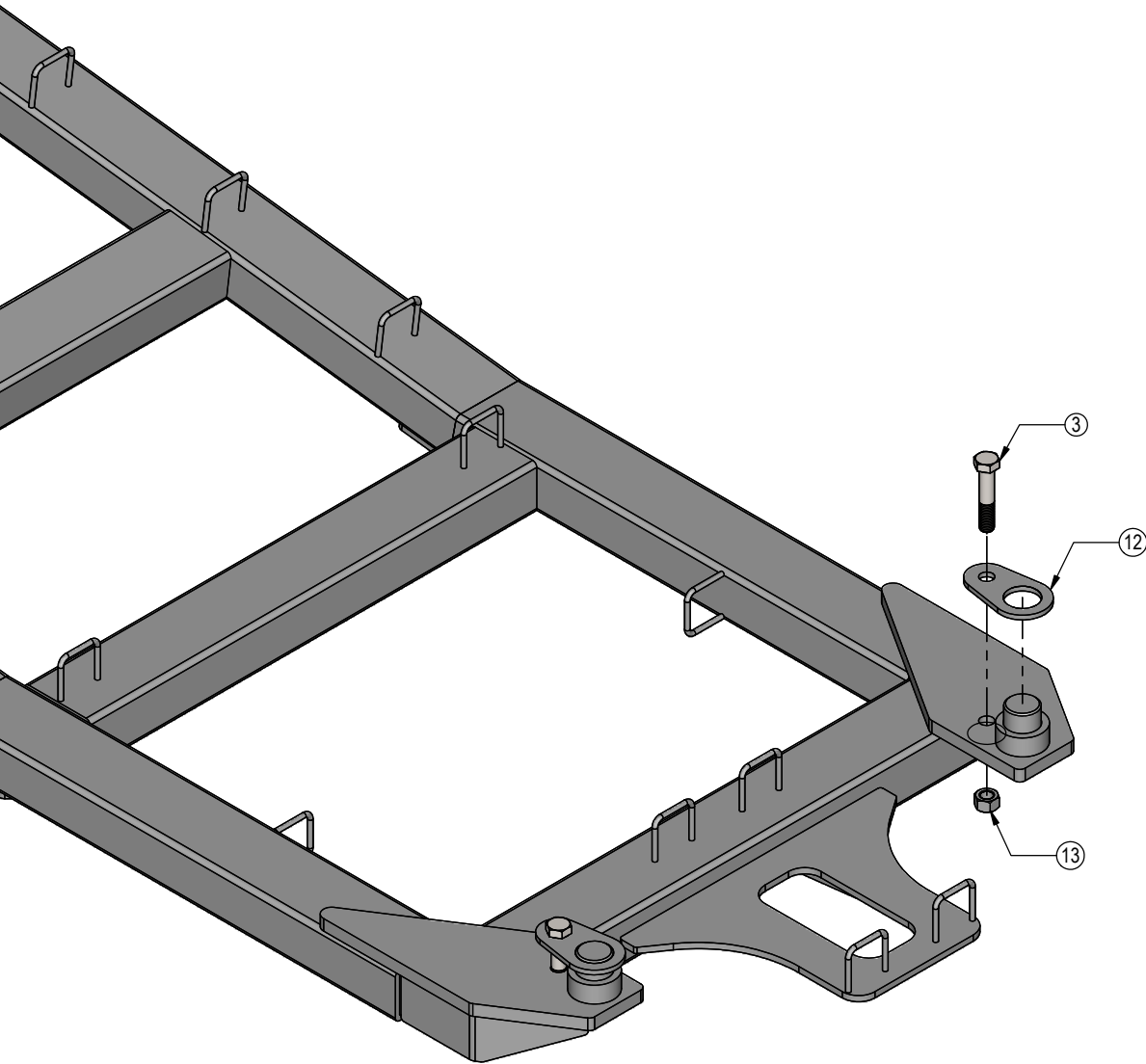

DWG. NO.: 40540-A

Improvements

Grouser Products Inc. is continually striving to improve its products. We reserve the right to change prices, specification, or equipment at any time without notice. We also reserve the right to make improvements or changes when it becomes practical and possible to do so without incurring any obligation to make changes or additions to the equipment sold previously.

Warranty

Grouser Products warrants to the original purchaser of each item that the product be free from defects in material and workmanship under normal use and service for a period of **two (2) years for Agriculture Series Blades and one (1) year for Heavy Duty Series from date of original retail delivery.**

The obligation of the consumer under this warranty:

1. To read the operators manual and to operate, lubricate, maintain and store equipment in accordance with the instructions listed in the operators manual.
2. To inspect equipment and if any part needs repair or replacement when continued use would cause damage or wear to other parts or safety.
3. All equipment or parts claimed to be defective in material or workmanship must be made available for inspection at the place of business of a dealer authorized to handle the equipment covered by this warranty, or, upon request by Grouser Products, shipped to the Grouser Products factory in West Fargo, North Dakota.

The obligation of the dealer under this warranty:

1. Complete warranty registration form and submit within 30 days of sale.
2. Contact Grouser Products for authorization prior to performing any warranty repairs or part replacement.
3. Complete warranty request form and submit with photos and supporting documentation.

The obligation of Grouser Products under this warranty:

1. Repair or replace, any equipment or parts, in the judgment of Grouser Products to be defective in material or workmanship.
2. Grouser Products will cover the cost of parts and ground shipping at dealer invoice only.
3. Grouser Products shall have no obligation to bear the cost of labor or transportation in connection with replacement or repair of any such defective parts.

This warranty does not cover:

1. Depreciation or damage caused by normal wear, accident, improper assembly, improper adjustments.
2. Improper maintenance including lack of proper lubrication, or improper use. Including loose bolts, nuts, or fitting due to over tightening or vibration after 20 hours of operation.
3. Repairs or alterations without authorization from a Grouser Products representative.
4. Grouser Products shall have no liability if the equipment has been altered or reworked without the written authorization of Grouser Products.

Grouser Products' parts, which are furnished under this warranty and properly installed, shall be warranted to the same extent as the original parts under this warranty if, and only if, such parts are found to be defective within the original warranty period covering the original equipment.

NO EMPLOYEE OR REPRESENTATIVE OF GROUSER PRODUCTS IS AUTHORIZED TO CHANGE THE WARRANTY IN ANY WAY OR GRANT ANY OTHER WARRANTY.

Contact Us

As always, if you have any questions about your system or other products made by Grouser, feel free to contact us.



755 2nd Ave NW - West Fargo, ND 58078
+1 701-282-7710 | info@grouser.com
www.grouser.com