



# Case Magnum T4A/B Front Support w/ HD PST & CVT Series Undercarriage Installation Instructions

## Caution:

- Always use precaution when working around any equipment.
- Always wear safety glasses.
- Follow tractor manufacturer's safety guidelines when installing this product.
  1. Read all instructions prior to installation.
  2. Remove the hose clamps on each rear side of the front 3-point frame to allow more access at the rear 4 bolts on the front 3-point frame.
  3. Remove the cover from below the front 3-point frame that protects the front hoses.
  4. Remove the 4 rear bolts that attach the front 3-point frame to the bottom of the tractor frame.
  5. Where the previous bolts were removed, install the front support brackets with 2 - 20mm x 90mm bolts with a 3/4" hardened washer on each bolt for each bracket. Tighten finger tight. See attached diagram for any clarification.
  6. Install 2 - 1" x 6" bolts and 2 - 1" nuts on the end of the front support. Turn the 1" bolts in for installation. The bolts will be adjusted after the push pole is installed. See the attached diagram for proper installation of the bolts and nuts.
  7. Position the front support under the tractor and center with the frame of the tractor.
  8. Lift the front support and attach to the front brackets with a 6 - 3/4" x 2" bolts, 12 - 3/4" hardened washers, and 6 - 3/4" nuts. Tighten finger tight. See the attached diagram for any clarification.
  9. Use 7 - 20mm x 50mm bolts and 7 - 3/4" flat washers to attach the left rail to the tractor frame.
  10. For tractors with suspended axles, loosen the bracket that holds the hydraulic fitting on the right side that is directly above the center bolt hole of the right bracket.
  11. Use 7 - 20mm x 50mm bolts and 7 - 3/4" flat washers to attach the right rail to the tractor frame. Don't install a bolt in the bottom rear bolt hole if tractor has a suspended axle.
  12. Attach the left and right rails to the rear of the undercarriage with 4 - 1" bolts, 8 - 1" heavy duty flat washers, and 4 - 1" nuts.
  13. Once all bolts are installed, push the front support forward so the vertical uprights are pushing against the front 3-point frame and then torque the front 20mm bolts to 432 ft-lbs. and the 3/4" bolts to 257 ft-lbs.
  14. Torque the 20mm bolts on the side rails to 432 ft-lbs.
  15. Torque the 1" bolts attaching the side rails to the U/C to 903 ft-lbs.

- 16.** Tighten the bracket down that was loosened in Step #10 if tractor has suspended axle.
- 17.** Reinstall the hose clamps from Step #2. Adjust the clamps if necessary or turn them around so the hoses are not tight up against any of the new installed components.
- 18.** Reinstall the cover that was removed in Step #3 and use new 12mm x 40mm bolts and 1/2" flat washers for the rear bolts. The cover will fit over the brackets that were installed. Cover may need to be bent a little to fit correctly.
- 19.** Position the push pole under the tractor. See the attached diagram for the correct orientation of the push pole.
- 20.** Slide the push pole onto the rod at the rear of the front support.
- 21.** Lift the rear of the push pole up to the drawbar bracket.
- 22.** Screw in a 1" bolt on each side of the push pole all the way until they are tight and are resting on the top of the drawbar bracket.
- 23.** Push the push pole back tight against the drawbar bracket.
- 24.** Unscrew the two 1" x 6" bolts at the front of the push pole until they are tight against the push pole. Torque the 1" bolts to 90-95 ft-lbs.
- 25.** Tighten the nuts up tight against the push pole. Use the nuts to lock the bolts in place.
- 26.** After first 8 hours of use, re-torque all bolts.
- 27.** Check all fasteners regularly to ensure proper operation of equipment.

THE INFORMATION CONTAINED IN THIS DRAWING IS THE SOLE PROPERTY OF GROUSER PRODUCTS INC ANY REPRODUCTION IN PART OR WHOLE WITHOUT THE WRITTEN PERMISSION OF GROUSER PRODUCTS INC IS PROHIBITED.

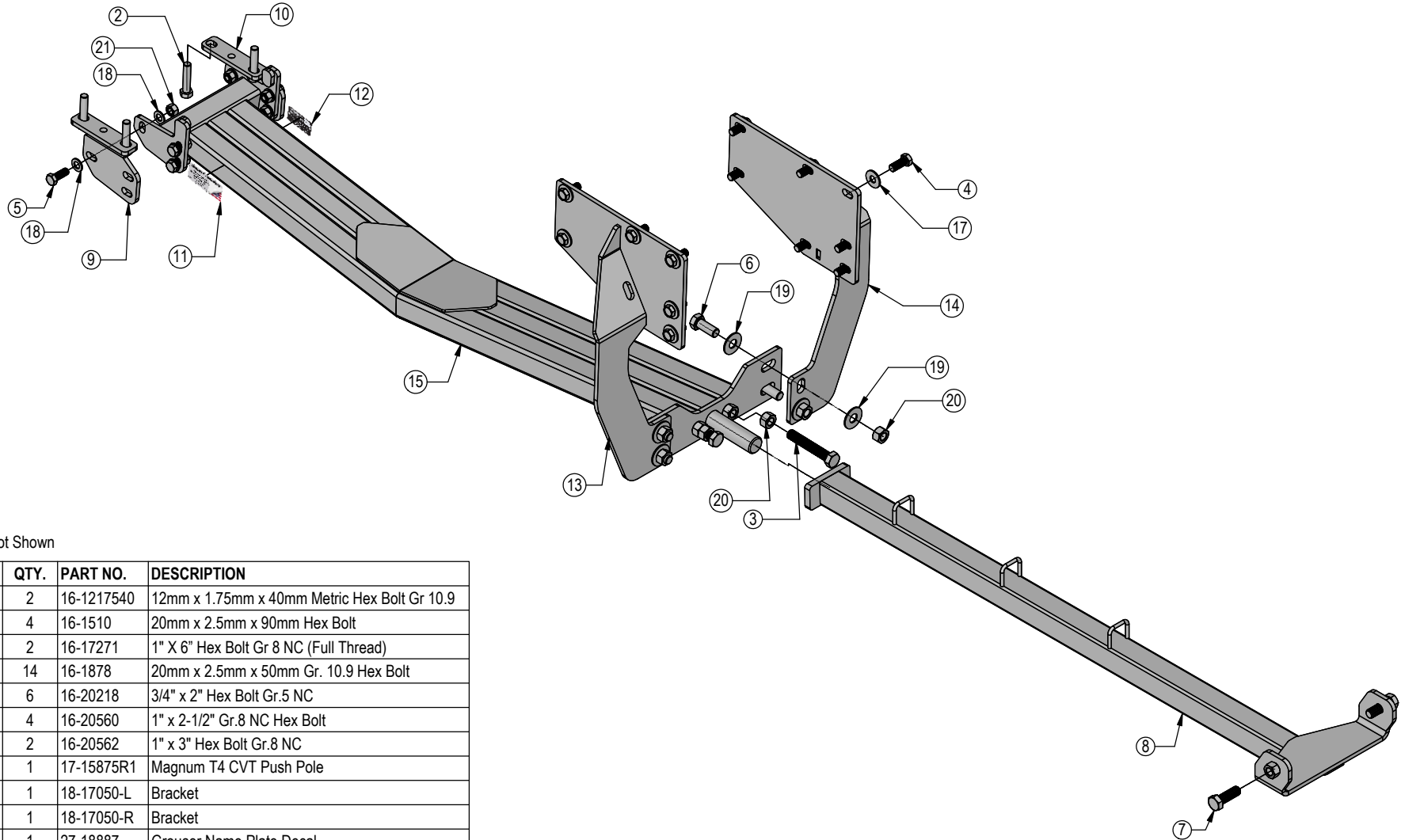

\* Parts Not Shown

ITEM NO.	QTY.	PART NO.	DESCRIPTION
1*	2	16-1217540	12mm x 1.75mm x 40mm Metric Hex Bolt Gr 10.9
2	4	16-1510	20mm x 2.5mm x 90mm Hex Bolt
3	2	16-17271	1" X 6" Hex Bolt Gr 8 NC (Full Thread)
4	14	16-1878	20mm x 2.5mm x 50mm Gr. 10.9 Hex Bolt
5	6	16-20218	3/4" x 2" Hex Bolt Gr.5 NC
6	4	16-20560	1" x 2-1/2" Gr.8 NC Hex Bolt
7	2	16-20562	1" x 3" Hex Bolt Gr.8 NC
8	1	17-15875R1	Magnum T4 CVT Push Pole
9	1	18-17050-L	Bracket
10	1	18-17050-R	Bracket
11	1	27-18887	Grouser Name Plate Decal
12	1	NA	Grouser Dozer Metal Serial Tag
13	1	44-14933-L	Side Plate, Left
14	1	44-14933-R	Side Plate, Right
15	1	54-17040R2	Undercarriage Weld
16*	2	57-20744	1/2" Flat Washer
17	14	57-20747	3/4" Flat Washer
18	16	57-20757	3/4" Flat Washer - 1-1/2" OD
19	8	57-20819	1" Flat Washer Heavy Duty Gr 8 (USS)
20	6	70-20599	1" Hex Nut Gr 8 NC
21	6	70-20607	3/4" Center Lock Hex Nut NC



**GROUSER PRODUCTS INC.**

755 2nd Ave NW Phone 701.282.7710  
 West Fargo, ND 58078 Fax 701.282.8131  
 WWW.GROUSER.COM

TITLE: Case Magnum T4A/B Front Support

Date: 10/25/2018 DWG. NO.: 40985-A



# Torque Arm - Front Hitch

## Installation Instructions

### Caution:

- Always use precaution when working around any equipment.
- Always wear safety glasses.
- Follow tractor manufacturer's safety guidelines when installing this product.
- Read all instructions prior to installation.
  1. Set the front hitch arms to the fixed position. The front hitch arms cannot be in float with the torque arm installed.  
**!!!The front hitch arms cannot be in float with the torque arm installed!!! Refer to tractor manufacturer's operator's manual for front hitch arms fixed position pin location.**
  2. Position the torque arm between the front hitch arms. The longest edge of the plate should be closest to the tractor and the angled edge on the bottom. See the photo below for correct orientation.
  3. Support the torque arm and install a bolting plate with 4 - 3/4" x 3-1/2" bolts and 4 - 3/4" nuts on each side.
  4. Once the bolts are all installed, push the torque arm evenly towards the tractor. Keep the torque arm parallel to the front of the tractor.
  5. Torque the 3/4" bolts to 100 ft-lbs.
  6. After first 8 hours of use, re-torque all bolts.
  7. Check all fasteners regularly to ensure proper operation of equipment.

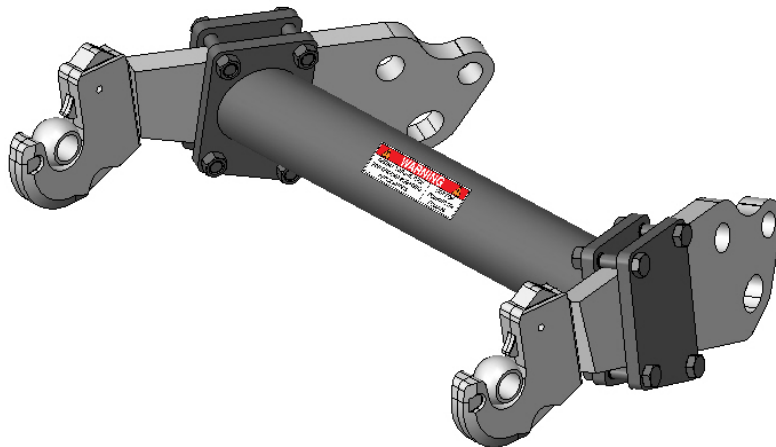

Note: The style of front hitch arms may vary slightly.



THE INFORMATION CONTAINED IN THIS DRAWING IS THE SOLE PROPERTY OF GROUSER PRODUCTS INC ANY REPRODUCTION IN PART OR WHOLE WITHOUT THE WRITTEN PERMISSION OF GROUSER PRODUCTS INC IS PROHIBITED.

ITEM NO.	QTY.	PART NO.	DESCRIPTION
1	1	11-19719	Torque Arm
2	8	16-20224	3/4" x 3-1/2" Gr.5 Hex Bolt NC
3	1	27-40405	Warning Decal - Torque Arm
4	2	44-19716	Plate
5	8	70-20607	3/4" Center Lock Hex Nut NC

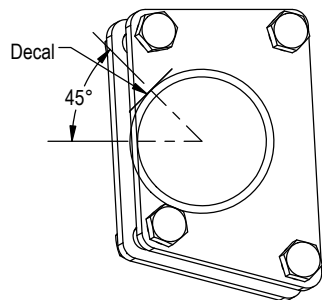
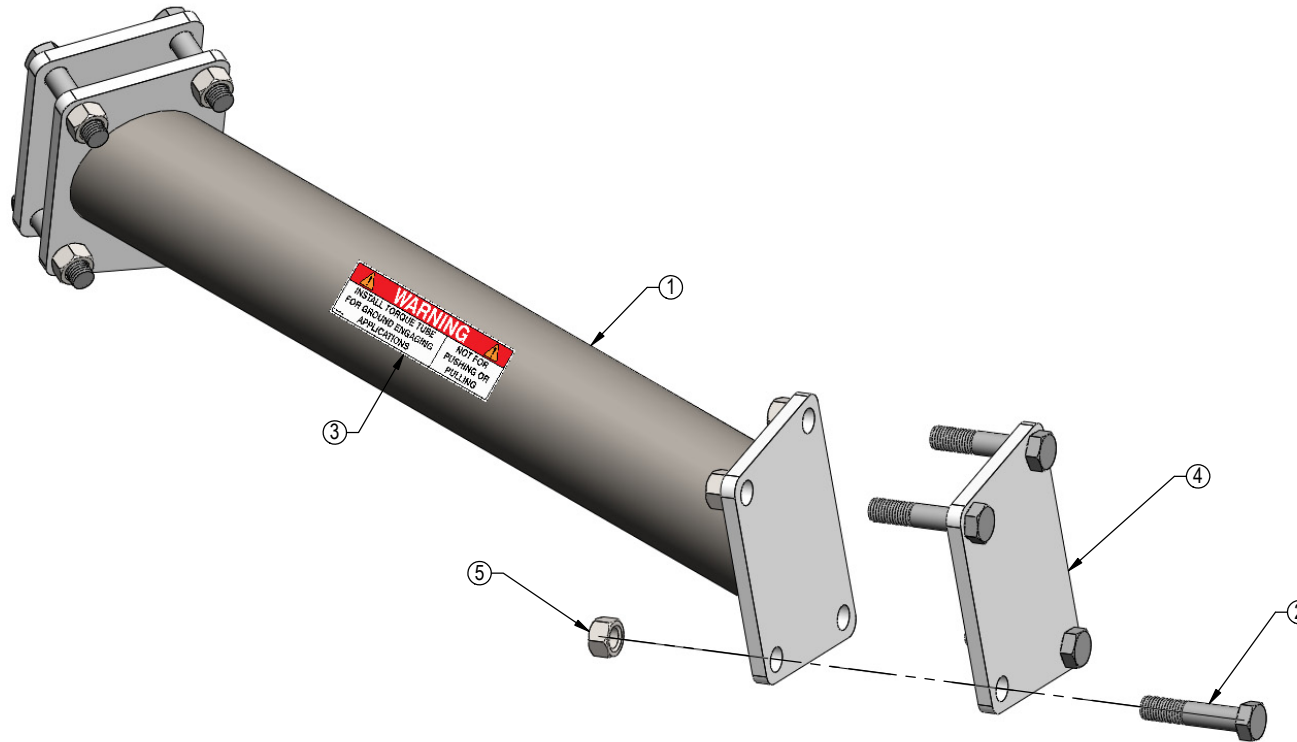

Placement of Warning Decal



**GROUSER PRODUCTS INC.**

755 2nd Ave NW Phone 701.282.7710  
 West Fargo, ND 58078 Fax 701.282.8131  
 WWW.GROUSER.COM

TITLE: Torque Arm for Front Hitches

Date: 2-16-2017

DWG. NO.: 19719-A