



770HD Steiger Quad 620

Owner's Manual & Parts Book

Grouser Products

755 2nd Ave NW - West Fargo, ND 58078

Phone: 1-800-747-6182

Fax: 1-701-282-8131

E-mail: grouser@grouser.com

Website: www.grouser.com

Purchase Date
Serial Number
Model Number
Tractor Model
Dealer

Description	Page
Welcome To The Owner & Torque Specifications	2
Safety Precautions & Maintenance	3
Undercarriage Installation Instructions	4-5
Assembling Lift Components and Initial Startup	6
Lift System	7
Hose Routing	8
Tilt Plate Adjustment & Top Arm Adjustment	9
Connecting and Disconnecting the Blade	9
No Angle - Hydraulic Tilt Hydraulics	10-11
Hydraulic Multi-Coupler Maintenance	12-13
Hydraulic Schematic	14
Notes	15
Contact Us, Improvements, & Warranty	16

Thank you for your recent purchase of a Grouser Undercarriage and Lift System. Welcome to the family of satisfied Grouser blade owners. Grouser Products is committed to offering quality products to help professionals in their daily jobs. We are also committed to providing you the highest level of customer satisfaction possible. Again, thank you for your patronage. We look forward to serving you.

This manual contains information concerning the operation, adjustment, safety and maintenance of the system. You have purchased a dependable, long lasting piece of equipment. You can expect to receive long lasting performance and long service built into our products with proper care and operation. Please have all operators read and understand this manual carefully. Keep the manual available for reference. If, for any reason, you have questions or comments, we would be happy to hear from you. Call our toll-free number, 800-747-6182, or send us an e-mail at info@grouser.com. You can expect us to respond to your e-mail in a timely manner.

Tighten all bolts to the values listed below unless otherwise noted. Refer to the parts lists for proper length and grade of the bolts.

Size	Torque - Dry (ft-lbs)			
	SAE Grade 5		SAE Grade 8	
	UNC	UNF	UNC	UNF
5/16	17	19	24	27
3/8	30	35	45	50
7/16	50	55	70	80
1/2	75	85	110	120
9/16	110	120	150	170
5/8	150	170	210	240
3/4	260	300	380	420
7/8	430	470	600	670
1	640	720	910	1020

Torque - Dry (ft-lbs)	
Size	Grade 10.9
M18 x 2.50	284
M20 x 2.50	401
M22 x 2.50	547
M24 x 3.00	694

A careful operator is the best operator. Most accidents can be avoided by observing certain precautions. To help prevent accidents, read and take the following precautions before operating this equipment. In addition, please follow all safety and operational instructions of your tractor manufacturer.

The 19' U-Blade:

1. The 19' U-Blade should be operated only by those who are responsible and instructed to do so.
2. Read the owner's manual carefully before using this equipment. Lack of operating knowledge can lead to accidents.
3. Keep the 19' U-Blade maintained in reliable and satisfactory condition to ensure your safety.
4. Make sure the area is clear of people before moving any equipment.
5. Do not modify or permit anyone else to modify or alter the equipment and its components without first consulting Grouser Products.
6. Lower the blade to the ground when not in use.

Servicing the 19' U-Blade:

1. Read and follow all safety instructions provided by the tractor manufacturer.
2. Always use proper personal safety gear when performing maintenance on equipment.
3. Before servicing, relieve hydraulic pressure, stop engine and fully engage parking brake.
4. Escaping hydraulic fluid under pressure can penetrate skin causing serious injury. If fluid is injected into skin, obtain medical attention immediately.
 - DO NOT use your hand to check for leaks. Use a piece of cardboard or paper to search for leaks.
 - Stop the engine and relieve pressure before connecting or disconnecting lines.
 - Tighten all connections before starting the engine or pressurizing lines.

Storing the 19' U-Blade:

1. Thoroughly clean the inside and outside of the 19' U-Blade before storage. Use paint where necessary to prevent rust.
2. Check the 19' U-Blade for worn or damaged parts. Install new parts as required.
3. Lubricate all pins and joints.

Due to the harsh environment this equipment operates in, the following tasks should be performed every 10 hours or less.

- Inspect all equipment before operation for existing or potential damage.
- Lubricate all joints with high quality grease.
- Inspect all bolts, and tighten any loose bolts to torque specifications on page 2.
- Check hydraulic cylinders and hoses for damage or leaks. For replacement parts, see hydraulic pages 7 & 10-11.
- Make sure all non-rotating pins are secured properly.
- Inspect all decals and order replacement decals from your dealer if any are damaged or worn.
- For multi-coupler maintenance, see pages 12-13.
- Inspect all tilt-ways for wear. See page 9 for tilt plate adjustment.
- Replace parts with original parts only.

Caution:

- Always use precaution when working around any equipment.
- Always wear safety glasses.
- Follow tractor manufacturer's safety guidelines when installing this product.

1. Read all instructions prior to installation.
2. Remove existing toolboxes, front weights, and tow cable holder if equipped. Tow cable can be reinstalled later if a bracket is purchased from Grouser Products.
3. If the bulkhead bracket (PN: 18-14370) is not factory installed, attach to the undercarriage with 2 - 1/2" x 1-1/4" bolts (PN: 16-20125) and 1/2" flat washers (PN: 57-20744). See pages 7 and 10-11 for bulkhead fittings, steel lines, and hose locations.
4. If bulkhead covers (PN: 44-14375 & 44-14376) are not factory installed, verify that all hydraulics are installed correctly and then attach the covers to the U/C with 6 - 1/2" x 1-1/4" bolts (PN: 16-20125) and 1/2" flat washers (PN: 57-20744).

NOTE: If rear 1" bolts are installed on the undercarriage, back out so the undercarriage will fit on the rear plate on the tractor frame.

5. Drill out holes in the tractor frame that line up with the front holes on the undercarriage to 1".
6. Position the undercarriage (U/C) under tractor and center on the frame of the tractor.
7. Lift the rear of the U/C up and set the top plates of the U/C on the cross member. Push the U/C back until the vertical push plates are firmly against the cross member. Lift the U/C to within 3/4" of touching the tractor frame.
8. Insert 8 - 1" x 3-1/2" bolts (PN: 16-20564) with a 1" hardened flat washer (PN: 57-20759) on each bolt through the front holes of the tractor frame that line up with the front vertical holes of the U/C.
9. After all bolts are through the tractor frame and U/C, attach with a 1" heavy washer (PN: 57-3682) and a 1" nut (PN: 70-20599). Verify that the rear of the U/C is firmly against the cross member.
10. At the rear of the undercarriage and pivot area of the tractor, hook the rear hose routing bracket to the tractor frame and bolt to the rear of the undercarriage with 1" x 3" bolts (PN: 16-20562), 1" hardened flat washers (PN: 57-20759) and 1" nuts (PN: 70-20599). The nut will fit between the plates on the brackets. See attached diagram for clarification.
11. Center the bracket on the undercarriage and tractor as close as you can. Torque the 1" bolts to 600 ft-lbs. There can be a gap between the bracket and the undercarriage.
12. Tighten the rear vertical bolts up tight against the bottom of the tractor frame. Torque the rear vertical 1" bolts to 500-600 ft-lbs.
13. Torque front 1" vertical bolts to 903 ft-lbs..
14. Attach the upper support arms (PN: 11-17740-R,L) to the U/C with 2 - 1" x 3-1/2" bolts (PN: 16-20564), 4 - 1" heavy duty flat washer (PN: 57-20819), and 2 - 1" nuts (PN: 70-20599) on each side of the U/C.
15. Attach the upper support arms to the tractor with a 1-1/4" x 3-1/2" bolt (PN: 16-20896) and a 1-1/4" flat washer (PN: 57-11671) on each side.
16. Remove the 2 - 24mm bolts and spacers from front axle on the left and right side of the tractor. Discard the spacers.
17. Attach the quad yoke brackets (PN: 18-14550-R,L) to each side of the U/C with 6 - 1" x 2" bolts (PN: 16-20558) and a 1" x .375" thick washer (PN: 57-3682) on each bolt.
18. Dip the previously removed 24mm bolts in W30 oil and install the yoke brackets with the 24mm bolt and a heavy flat washer (PN: 57-20819) on each bolt.
19. Once all bolts have been installed, torque the 1-1/4" bolts to 1,105 ft-lbs., the 1" bolts to 903 ft-lbs, and the 24mm bolts to 555 ft-lbs.
20. Bolt the side bolt cover (PN: 44-15575) to both sides of the undercarriage with 1/2" x 1-1/4" bolts (PN: 16-20125) and a 1/2" flat washer (PN: 57-20744) on each bolt.
21. Attach the bottom covers (PN: 44-14382-R,L) to the undercarriage with 1/2" x 1-1/4" bolts (PN: 16-20125) and 1/2" flat washers (PN: 57-20744).
22. After first 8 hours of use, re-torque all bolts. Check all fasteners regularly to ensure proper operation of equipment.

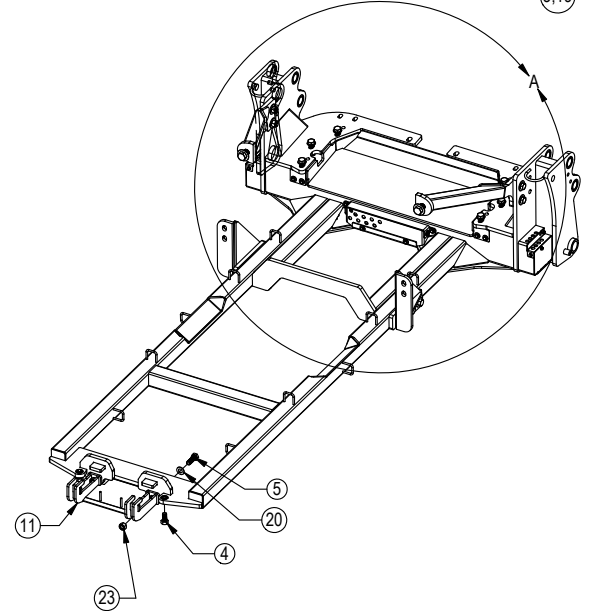
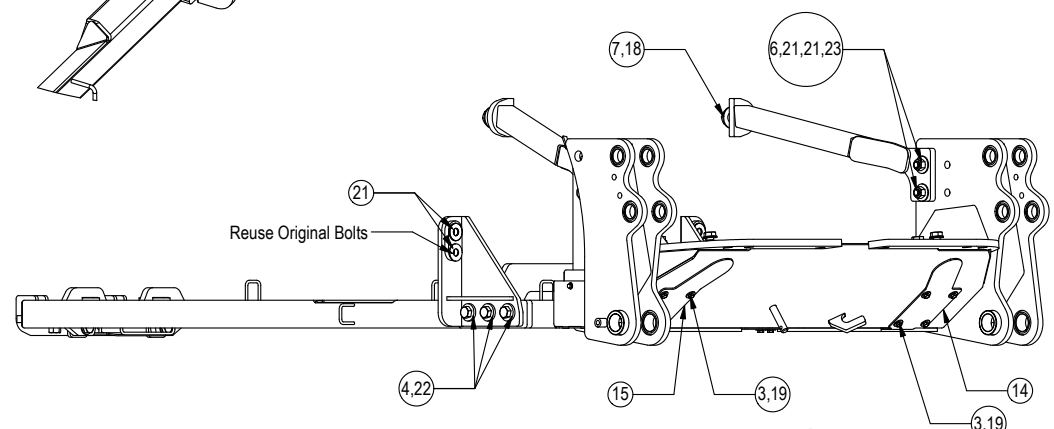
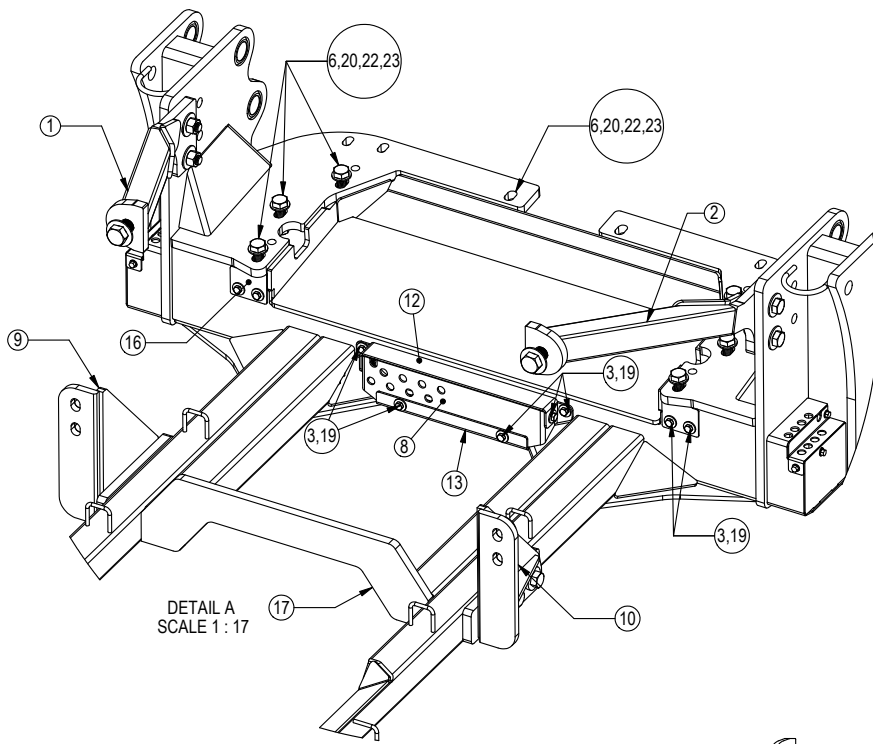

* Parts Not Shown

Item No.	Qty.	Part No.	Description
1	1	11-17740-L	Upper Undercarriage Support Arm Left - Quad Tier 4B
2	1	11-17740-R	Upper Undercarriage Support Arm Right - Quad Tier 4B
3	20	16-20125	1/2" x 1-1/4" Hex Bolt Gr 5 NC
4	8	16-20558	1" x 2" Hex Bolt Gr 8 NC
5	2	16-20562	1" x 3" Hex Bolt Gr 8 NC
6	12	16-20564	1" x 3-1/2" Hex Bolt Gr 8 NC
7	2	16-20896	1-1/4" x 3-1/2" Hex Bolt Gr 5 NC Zinc
8	1	18-14370	Bracket, Bulkhead - AG Wide Frame
9	1	18-14550-L	Steiger Quad Yoke Bracket - Left
10	1	18-14550-R	Steiger Quad Yoke Bracket - Right
11	1	18-17280	Hose Routing Bracket
12	1	44-14375	Plate, Top Bulkhead Cover - AG Wide Frame
13	1	44-14376	Plate, Bottom Bulkhead Cover - AG Wide Frame
14	1	44-14382-L	Plate, Bottom Cover Left - AG Wide Frame
15	1	44-14382-R	Plate, Bottom Cover Right - AG Wide Frame
16	2	44-15575	Plate, 770 Undercarriage Side Bolt Cover
17	1	54-19297	770HD Steiger / T9 Large Frame Quad and Wheeled UC
18	2	57-11671	1-1/4" Flat Washer
19	20	57-20744	1/2" Flat Washer
20	10	57-20759	1" SAE Hardened Flat Washer - 2" OD
21	12	57-20819	1" Flat Washer Heavy Duty Gr 8 (USS)
22	14	57-3682	2.50 OD X 1.00" ID x .375" Washer CZ Plated
23	14	70-20599	1" Hex Nut Gr 8 NC

TITLE:
770 Steiger Quad UC Assy.

Now that the undercarriage is installed, some assembly of components is necessary. Follow the steps listed below. Refer to Page 7 for the correct hardware and orientation of parts.

1. Remove all pins on each side of the undercarriage.
2. Position the lift frame between the two plates on both sides of the undercarriage.
3. Align the lift frame to the bottom holes of the undercarriage and attach with the proper pins and hardware.
4. Lift the end of the cylinders up and attach to the undercarriage with the proper pins and hardware.
5. Attach the top arms to the top of the undercarriage with the proper pins and hardware.
6. Attach the multi-coupler to the left top arm. See Page 10 or 11 for proper orientation.
7. Take the lift hoses that are already attached to the furthest forward fittings on the left and right side of the undercarriage and attach them to the lift cylinders.

Note: For Step #8-10, refer to Page 10-11 for further information on hose routing and hose positions.

8. Run the remaining hoses thru the hose loop on the top arm and attach a straight fitting to all the hoses.
9. Install the attached fitting and hoses to the multi-coupler.
10. Take the 293" and 300" hoses and attach each one to their designated fitting at the center of the undercarriage.
11. Route the hoses thru the hose loops on the undercarriage.
Continue to route the hoses thru the tractor. Keep away from all moving parts. Refer to Page 8 for hose routing.
12. Plug the male couplers into the rear SCV's on the tractor

Start the tractor and run the blade thru all the functions. If any function does not work properly, bleeding of the system may be required. If problem still persists, call Grouser Products.

ITEM NO.	QTY.	PART NO.	DESCRIPTION
1	1	11-41790-L	Manual Pitch Top Arm
2	1	11-41790-R	Manual Pitch Top Arm
3	6	16-35C612	3/8" x 3/4" Flange Bolt
4	12	16-20566	1" X 4" Hex Bolt Gr 8 NC
5	2	16-20227	3/4" X 4-1/2" Hex Bolt Gr. 5 NC
6	6	16-20220	3/4" x 2-1/2" Hex Bolt Gr 5 NC
7	4	16-20216	3/4" x 1-1/2" Hex Bolt Gr 5 NC
8	2	16-20002	1/4" x 3/4 " Hex Bolt Gr 5 NC
9	1	18-15580-R	Bracket
10	1	18-15580-L	Bracket
11	8	19-13515	Spacer, NR Pin
12	2	25-34342	Tappet Quick Coupler Male
13	2	26-34750	5 x 20 Cylinder Bushed Tube Ends
14	2	31-11699-10-10	JIC Union
15	2	31-2406-12-10	JIC Reducer Expander
16	4	31-2700-10-10	Bulkhead Union JIC
17	2	31-34032	Bulkhead Run Tee JIC
18	2	31-34203	Straight Long JIC x O-Ring
19	2	31-34059	Straight Thread Elbow 90° JIC x O-Ring
20	2	31-34104	Swivel Nut Elbow 90° JIC -10 Male x -12 Female
21	2	31-34042	Straight JIC x O-Ring
22	1	32-17000	XHD Lift Frame Weld
23	2	34-12932	Cylinder Saddle
24	2	34-12933	Hose Clamp (worm drive - 5.0)
25*	8	34-19494-OR	Spiral Band - Orange

ITEM NO.	QTY.	PART NO.	DESCRIPTION
26	6	34-14898	Dome Plug (3044)
27	1	34-14961	Manual Canister Small
28	4	35-12632-0630	63" x 5/8" -10JIC/-10JIC Abrasion Resistant Hose
29	2	35-12637-3000	300" x 3/4" -12JIC/-12JIC Abrasion Resistant Hose
30	2	35-12931	Formed Steel Line
31	1	35-15557R1	Tube Assembly
32	1	35-15558R1	Tube Assembly
33	2	35-19416	Tube Assembly
34	1	43-12929-R,L	Pin Weld
35	1	43-12929-R,L	Pin Weld
36	2	43-13478	Pin Weld
37	4	43-13482	Pin Weld
38	2	43-14725	Lift Frame / UC Pin
39	2	43-14720	2.5" X 9" NR Pin
40	2	44-15120R1	Plate
41	2	45-12175R4	Quick Attach Weld
42	10	57-20747	3/4" Flat Washer
43	2	58-9369	Straight 1/8" NPT Grease Zerk
44	4	58-9372	90° 1/8" NPT Grease Fitting
45	2	70-20580	1/4" Hex Nut Gr 5 NC
46	12	70-20599	1" Hex Nut Gr 8 NC
47	8	70-20607	3/4" Center Lock Hex Nut NC
48	4	70-20808	3/4" Hex Jam Nut NF
49	2	70-20809	1-1/16" Hex Jam Nut

* Part Not Shown

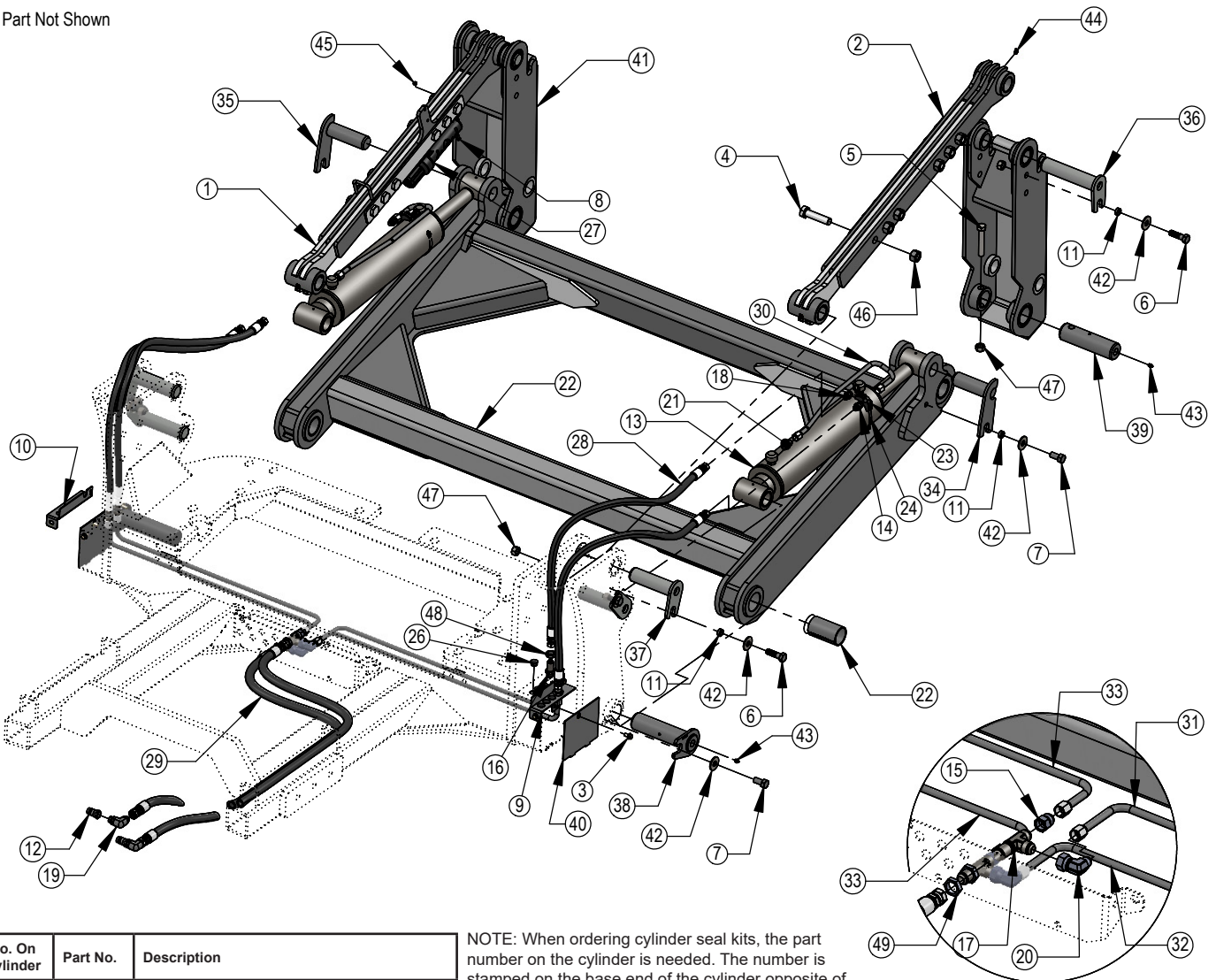

No. On Cylinder	Part No.	Description
26-34750	49-12275	Seal Kit 5 x 20 Nitrided Rod

NOTE: When ordering cylinder seal kits, the part number on the cylinder is needed. The number is stamped on the base end of the cylinder opposite of the hydraulic ports.

Item No.	Qty.	Part No.	Description
1	4	16-20139	1/2" x 5-1/2" Hex Bolt Gr 5 NC
2	1	44-17208	770 CNH Rear UC Hose Routing Plate
3	4	44-17245	770 CNH Hose Holding Plate
4	4	53-15528	Round Tube, Hose Routing Spacer - 3/4"
5	4	54-20744	1/2" Flat Washer
6	4	70-20604	1/2" Hex Center Lock Nut Gr 2 NC
7	2	70-20872-10	20mm Hex Nut 2.5 Pitch Class 10 Zinc

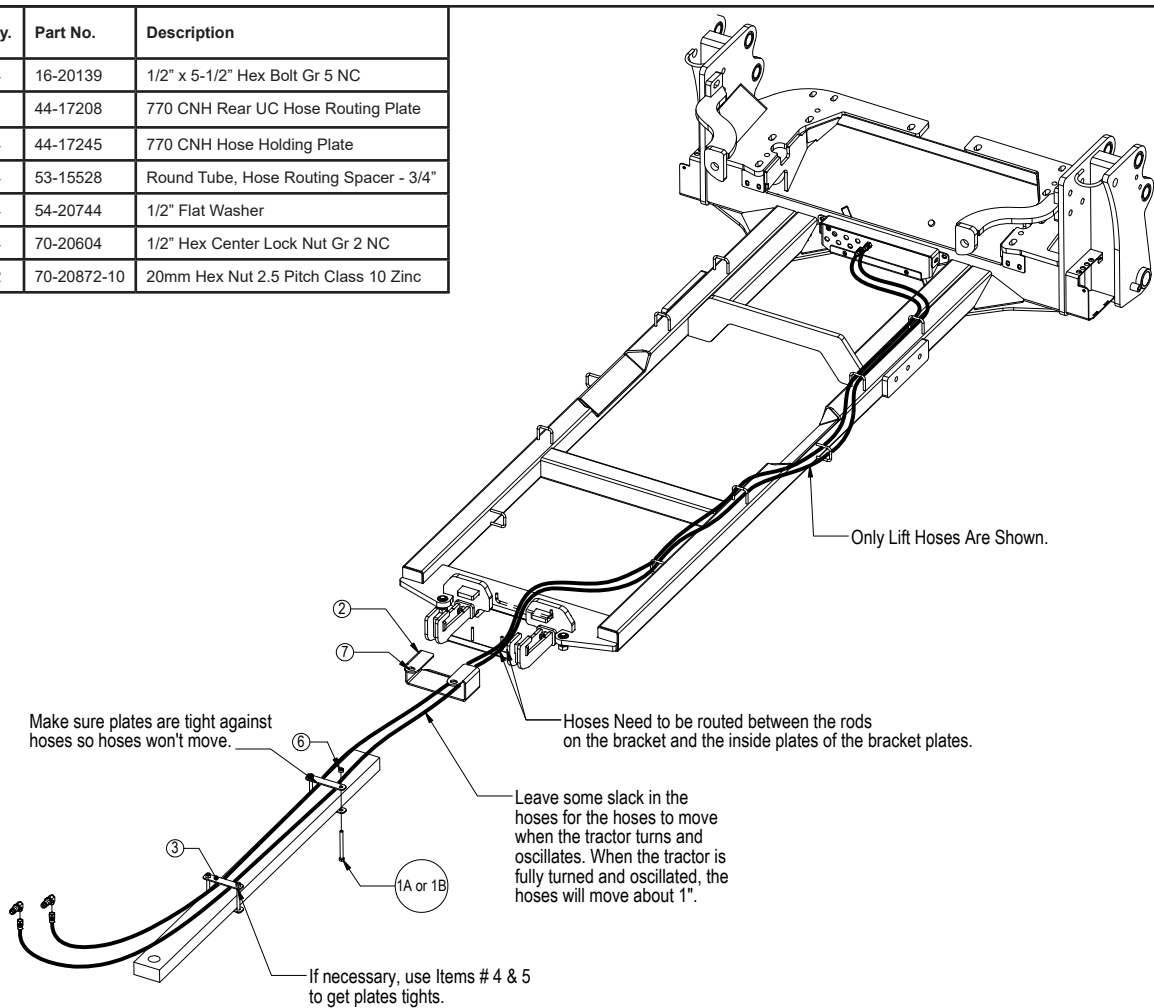

1. Attach the rear hose routing plate (PN: 44-17208) to the tractor frame behind the pivot point and before the drawbar. There will be 2 bolts sticking down. Attach with a 20mm nut (PN: 70-20872-10) on each side. Make sure the lip of the plate is facing towards the front of the tractor. See picture below for clarification.
2. Check all fasteners regularly to ensure proper operation of equipment.

For the following steps, refer to the hose routing diagram for further clarification.
3. Attach the 293" hoses to the front of the undercarriage where all the steel lines come to the center of the undercarriage.
4. Route all the hoses from the front of the undercarriage, thru the hose loops on the undercarriage and thru the large loop at the rear of the undercarriage. Send hoses thru the bracket at the pivot point but stay on the outside of the rods that are by the center large nut on the tractor. The hoses should be between the rods on the bracket and the inside plates of the bracket.
5. Route the hoses thru the hose routing plate that was installed in Step #1.
6. Use Zip Ties to group some hoses on the left and right side of the hose routing plate. Strap the zip Ties over the top part of the routing plate that is bolted to the tractor frame to keep the hoses towards the outside of each side of the routing plate.
7. Continue to route the hoses down the top of the drawbar to the back of the tractor where you can plug them into the tractor SCV Ports.
8. Strap the hoses to the drawbar with a set of hose holding plates (PN: 44-17245) in 2 locations. Place 1 set as close to the front of drawbar as possible and the other behind the axle before the hoses would be routed upwards to be plugged in.
9. Make sure to keep some slack in the hose between the pivot point of the tractor and the first set of hose holding plates. The hoses will move when the tractor moves and oscillates.
10. For each set of plates, use 2 - 1/2" x 5-1/2" bolts (PN: 16-20139) and 2 - 1/2" nuts (PN: 70-20604). Put the bolts in from the bottom with the nuts on the top.
11. Tighten the 1/2" nuts so the hoses are tight and don't move. If you have the nuts as far as they go and you can't get the plates tight against the hoses, use the provided 3/4" spacers (PN:34-15528) and a 1/2" washer (PN: 57-20744) between the plates and the nuts to get everything tight against the top of the drawbar.
12. Make sure you still have some slack in the hoses by the pivot area so the hoses don't get pulled too tight when the tractor moves but don't make them too lose that they will get caught on any debris. Turn the tractor and oscillate the tractor to verify there is enough slack.
13. After first 8 hours of use, re-torque all bolts.
14. Check all fasteners regularly to ensure proper operation of equipment.

Note: Don't remove all of the bolts at the same time.

1. The preferred blade position for adjusting the tilt plates is laying face down on blocks.
2. Remove bolts and tilt plates from the right tilt plates.
3. Add or remove washers as needed to adjust tilt-way clearance to have 1/16" - 1/8" of clearance in direction 'B' shown in Figure 1.
4. Reinstall the bolts on the right tilt plates.
5. Follow Steps #2-4 for the left side
6. Once the tilt-way clearance is set, tighten bolts to 640 ft-lbs.

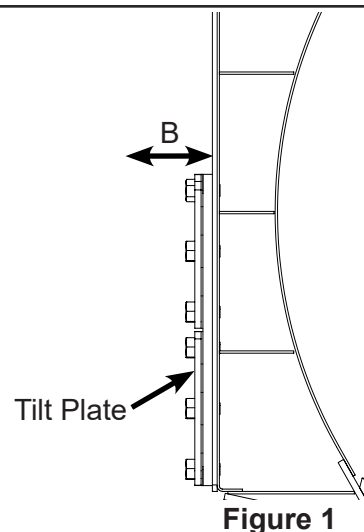
**Figure 1**

The pitch of the blade can be changed by adjusting the top arms.

1. Lower blade to the ground.
2. Shut off the tractor engine and set the parking brake.
3. Loosen all 1" bolts on both top arms.
4. Slide the top arms to your desired position. The use of a forklift may be needed to help push or pull the system to slide the arms in or out.
5. Tighten all 1" bolts on bolt top arms. Torque to 910 ft-lbs.

To Connect:

Note: If necessary, use a spotter to help center the blade on the lift system.

1. Remove the quick attach locking pin on both side of the tilt frame.
2. Drive the tractor forward slowly until the top hub of the male quick attach is under the top hook of the female quick attach on the tilt frame.
3. Raise the lift system until the male quick attach engages the female hook. If both sides don't fully engage, reposition. Continue to raise the lift system until the blade is off the ground and the tilt frame is against the front of the male quick attach.
4. Shut off the tractor engine and set the parking brake.
5. Reinstall the quick attach locking pin and slide the moving handle into the lock position on the step to lock the pin in place.
6. Raise blade stands on both sides and lock in the upward position
7. Clean and connect hydraulic multi-coupler on the top arm. Refer to Pages 16-17 for cleaning and connecting information.

To Disconnect:

1. Lower the blade until the cutting edge is off the ground a few inches.
2. Shut off the tractor engine and set the parking brake.
3. Unhook the multi-coupler on the top arm.
4. Remove the multi-coupler cover from the parking station and install on the multi-coupler on the top arm.
5. Plug the blade side multi-coupler into the parking station.
6. Pull out the quick attach locking pins and place in the pin holder at the top of the tilt frame.
7. Lower and lock blade stands in the lower position.
8. Start tractor, disengage the parking brake, and lower the blade until cutting edge is on the ground.
9. Continue to slowly lower the lift system to disengage the blade.
10. Slowly back away from the blade. When lift system is clear from the blade, raise the lift system.
11. Shut off the tractor engine and set the parking brake.

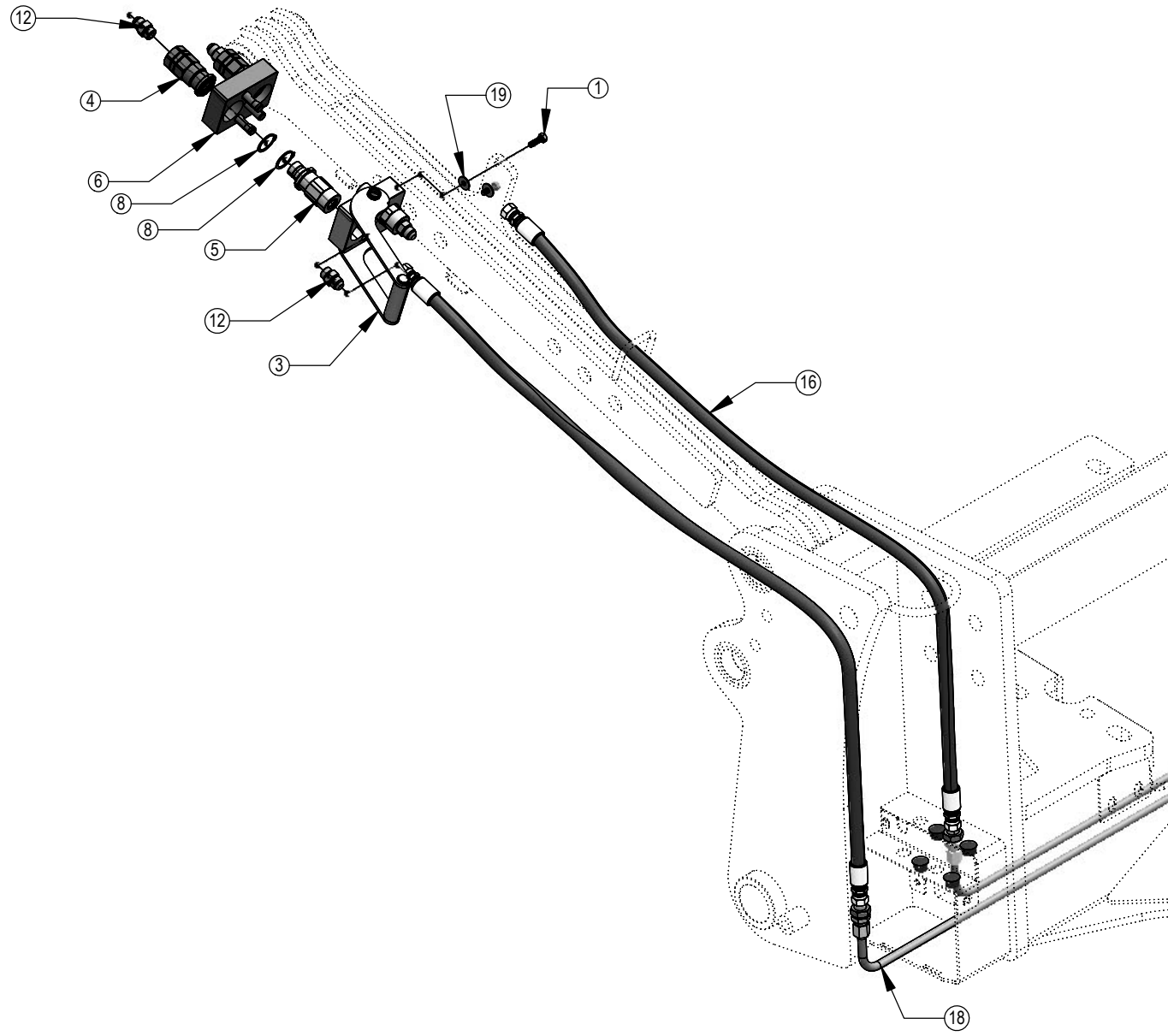

ITEM NO.	QTY.	PART NO.	DESCRIPTION
1	2	16-812525	8mm x 1.25mm x 25mm Metric Hex Bolt Gr 10.9
2*	1	25-19657	Multi-Coupling Plate - 2 Port Parking Station
3	1	25-19868	Multi-Coupling Plate - 2 Port - Fixed
4	2	25-19865	Female Coupler
5	2	25-19870	Male Coupler
6	1	25-19869	Multi-Coupling Plate - 2 Port - Mobile
7*	1	25-19871	Multi-Coupling Plate - 2 Port - Cap
8	4	25-40407	Snap Ring
9	2	25-34342	Tappet Quick Coupler Male - Poppet Style
10	2	25-3453	Pioneer Dust Cap Tilt (Green)
11	4	31-34000	Bulkhead Union JIC
12	4	31-34040	Straight JIC x O-Ring
13	2	31-34051	Straight Thread Elbow 90° JIC x O-Ring
14	14	34-14898	Dome Plug (3044)
15*	6	34-18888-GR	Spiral Band - Green
16	2	35-12631-0690	69" x 1/2" -8JIC/-8JIC Abrasion Resistant Hose
17	2	35-12631-2930	293" x 1/2" -8JIC/-8JIC Abrasion Resistant Hose
18	2	35-14352	Tube Assembly - Tilt
19	2	57-20740	1/4" Flat Washer
20	4	70-20807	3/4" Hex Jam Nut NF

* Parts Not Shown

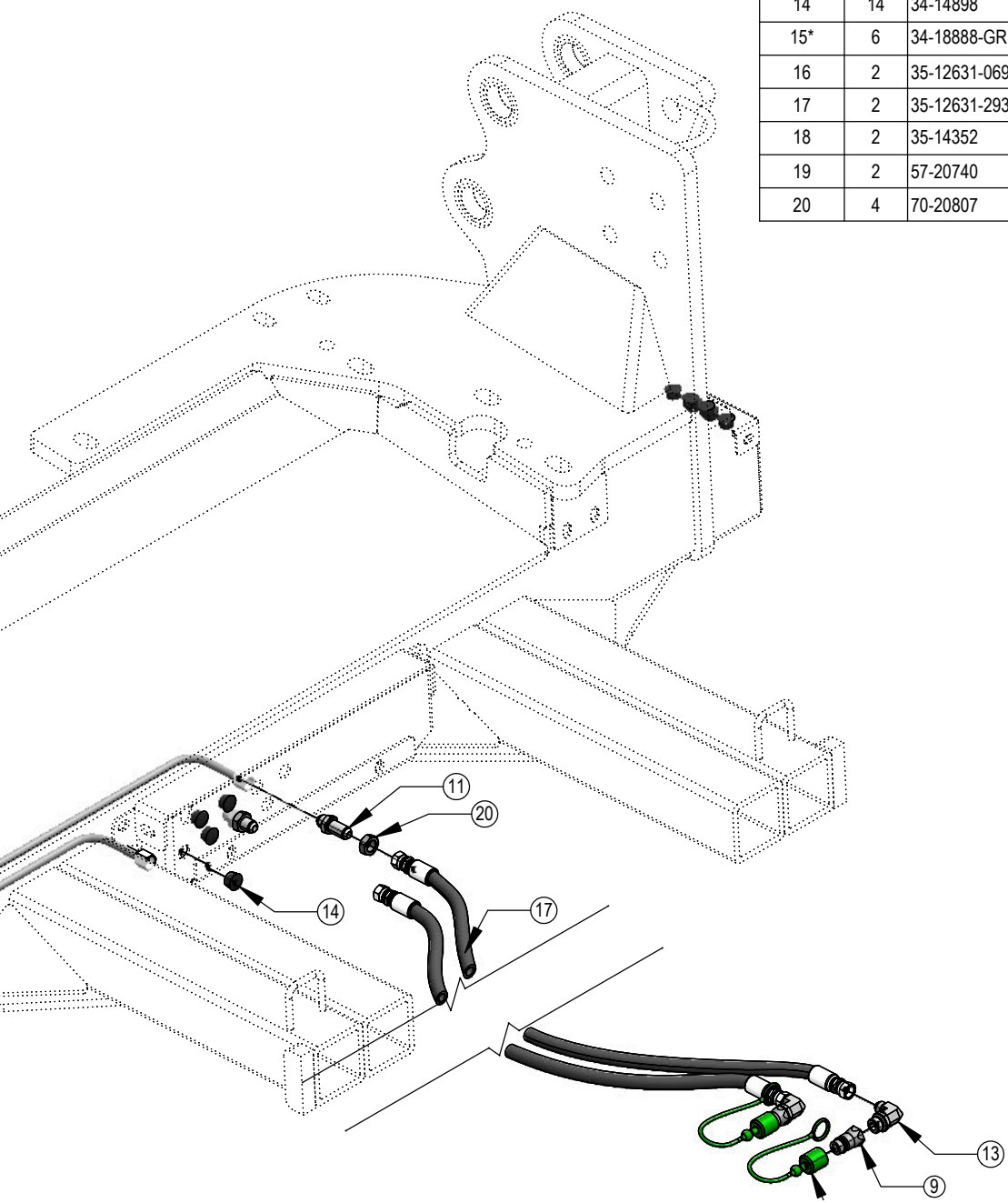

Before Each Use:

1. Disconnect the mobile half from the parking station and the cap from the fixed half.
2. Check that there is no contamination (salt, sand, dirt, etc.):
 - A. On the pins.
 - B. Inside the cam.
 - C. In the locking mechanism area.
 - D. On the face of the plates and couplings.
3. In case of contamination, remove it with a cloth and/or compressed air.
4. Check that there is still a lubricant/anti-corrosion (grease or silicone - see Note 1):
 - A. On the pins.
 - B. Inside the cam.
 - C. In the locking mechanism area.
5. Connect the mobile and fixed halves together.

After Each Use:

1. Disconnect the mobile half from the fixed half.
2. Clean all contamination (salt, sand, dirt, etc.) from the following areas:
 - A. On the pins.
 - B. Inside the cam.
 - C. In the locking mechanism area.
 - D. On the face of the plates and couplings.

*Use a cloth or compressed air. It is advised to not use water to clean these surfaces
3. Apply a lubricant/anti-corrosion (grease or silicone - see Note 1):
 - A. On the pins.
 - B. Inside the cam.
 - C. In the locking mechanism area.
4. Connect the cap to the fixed half and the mobile half to the parking station.

Note 1:

When sand and salt are present, or the plates under go a washdown, a heavy duty silicone spray lubricant should be used to replace grease from the factory. The lubricant should help protect from corrosion without collecting dust and contaminants, and will resist washing off when exposed to water.

Recommended Lubricant Brands:

Fluid Film (Aerosol or Non-Aerosol), LPS-2 Heavy Duty Lubricant, or CRC 3-36.

Fixed Half

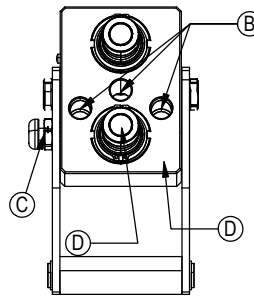

Mobile Half

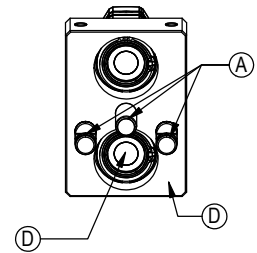

Cleaning The Male Interface Seal:



1. Make sure the coupling is securely fastened into the plate or place in a vice.



2. Using a blunt, non-marring tool, depress the valve face until the seal is exposed. Insert a bent metal wire between the valve face and the body of the coupling. Use caution not to damage or scratch the seal when inserting the wire.



3. Inspect the seal and interior surfaces for contamination.



4. In case of contamination, carefully wipe surfaces with a soft cloth, or use compressed air to blow the contamination out. Do Not press hard on the seal as contamination can scratch the seal surface.



5. Using a non-marring tool, depress the valve face and remove the metal wire. Release the valve to the flush position.

Cleaning The Female Bushing:



1. Make sure the coupling is securely fastened into the plate or place in a vice.



2. Using a non-marring tool, depress the outer ring to expose the bushing. There is no need to expose the valve seal, so stop pressing before the valve is opened.



3. Inspect the interior body and bushing surfaces for contamination.



4. In case of contamination, carefully wipe surfaces with a soft cloth, or use compressed air to blow the contamination out.



5. Release the outer ring so that it returns to the flush position.

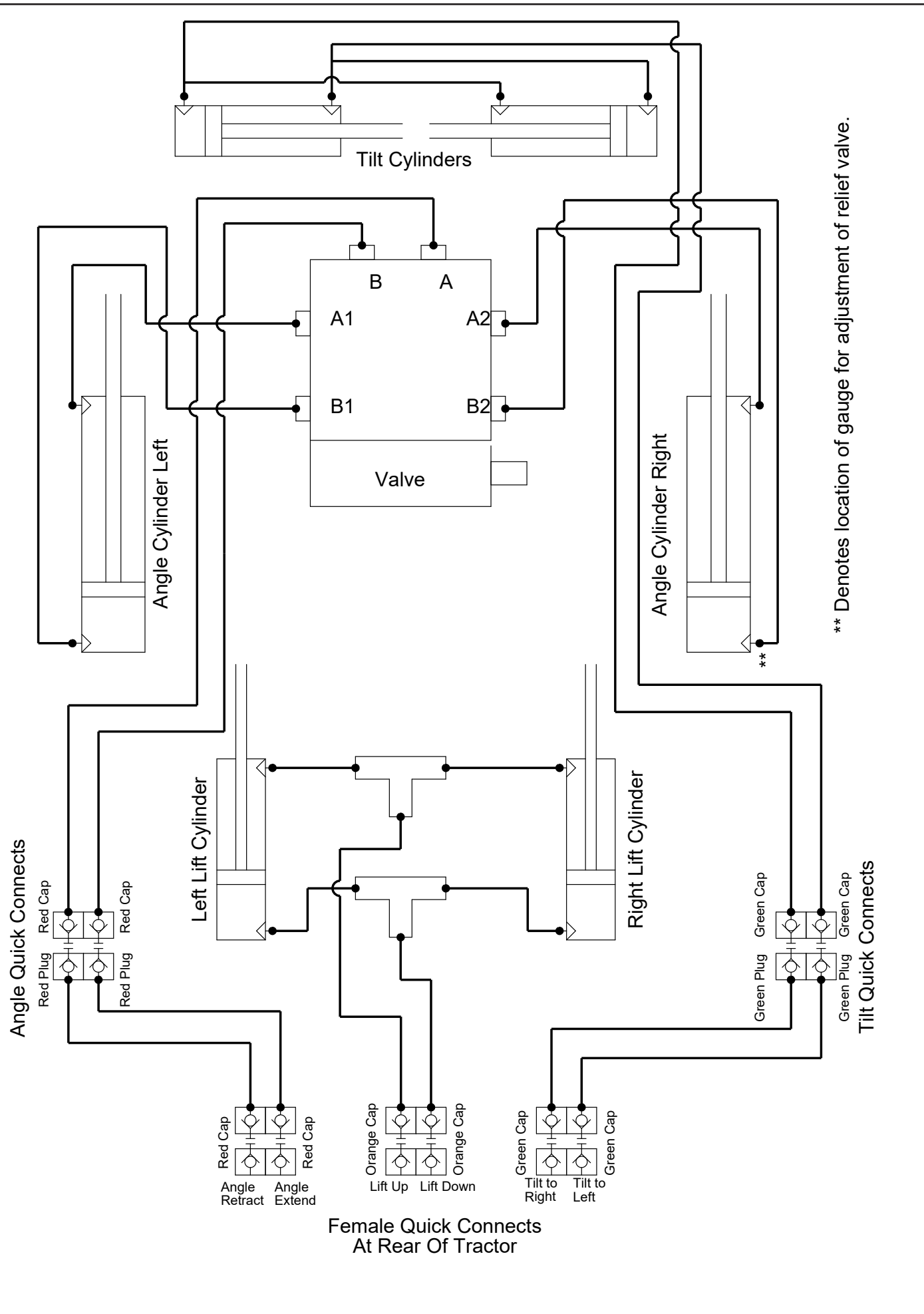

*** Denotes location of gauge for adjustment of relief valve.

Contact Us

As always, if you have any questions about your Ag Pro 770 Dozer or other products made by Grouser, feel free to contact us.

Grouser Products

755 2nd Ave NW - West Fargo, ND 58078

Phone: 1-800-747-6182

Fax: 1-701-282-8131

E-mail: grouser@grouser.com

Website: www.grouser.com

Improvements

Grouser Products Inc. is continually striving to improve its products. We reserve the right to change prices, specification, or equipment at any time without notice. We also reserve the right to make improvements or changes when it becomes practical and possible to do so without incurring any obligation to make changes or additions to the equipment sold previously.

Warranty

Grouser Products warrants to the original purchaser of each item that the product be free from defects in material and workmanship under normal use and service for a period of two years. If such equipment is found to be defective within two years, it is the obligation of Grouser Products under this warranty to repair or replace (exclusive of the cost of labor and transportation), any equipment or parts, in the judgment of Grouser Products to be defective in material or workmanship.

All equipment or parts claimed to be defective in material or workmanship must be made available for inspection at the place of business of a dealer authorized to handle the equipment covered by this warranty, or, upon request by Grouser Products, shipped to the Grouser Products factory in West Fargo, North Dakota. Grouser Products shall have no obligation to bear the cost of labor or transportation in connection with replacement or repair of any such defective parts in the setup process.

This warranty covers only defects in material and workmanship. It does not cover depreciation or damage caused by normal wear, accident, improper assembly, improper adjustments, improper maintenance including lack of proper lubrication, or improper use. Therefore, Grouser Products liability under this warranty shall not be effective or actionable unless the equipment is assembled, maintained and operated in accordance with the operating instructions accompanying the equipment. Grouser Products shall have no liability if the equipment has been altered or reworked without the written authorization of Grouser Products.

Grouser Products' parts, which are furnished under this warranty and properly installed, shall be warranted to the same extent as the original parts under this warranty if, and only if, such parts are found to be defective within the original warranty period covering the original equipment.

