

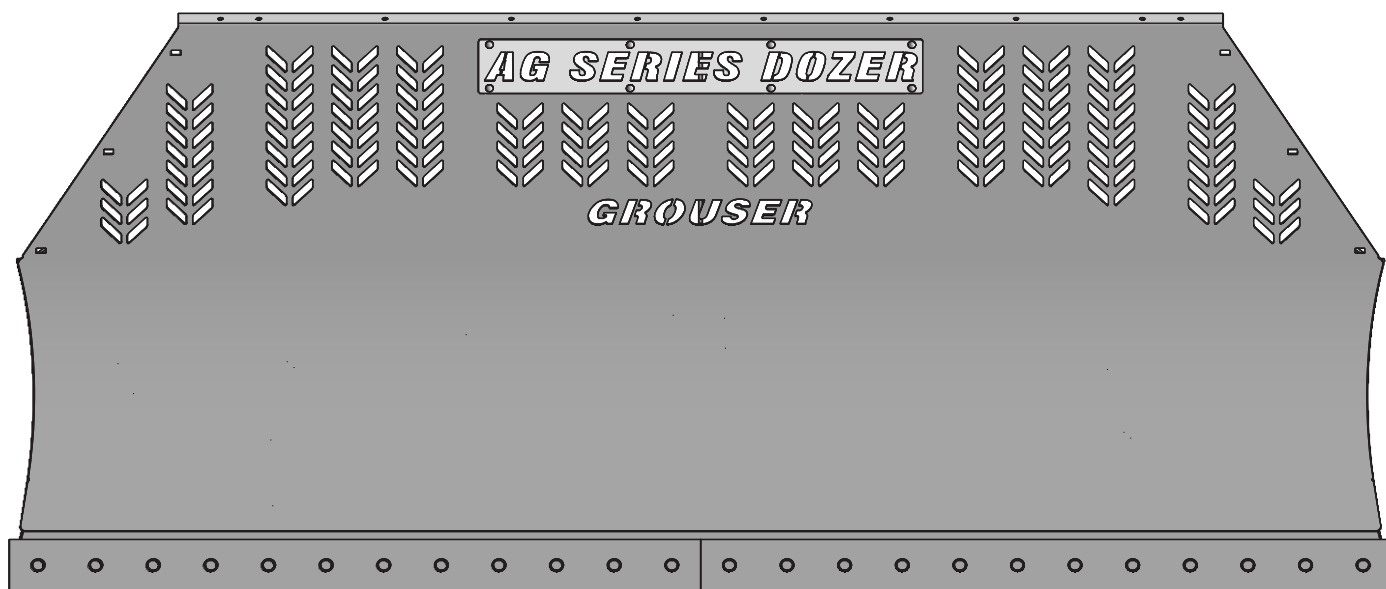

Ag 240I & 241I

Owner's Manual & Parts Book



Grouser Products

755 2nd Ave NW - West Fargo, ND 58078

Phone: 1-800-747-6182

Fax: 1-701-282-8131

E-mail: grouser@grouser.com

Website: www.grouser.com

Purchase Date
Serial Number
Model Number
Tractor Model
Dealer

Description	Page
Welcome To The Owner	2
Safety Precautions, Torque Specifications & Pre-Installation	3
Maintenance & Abbreviation Key	4
Top Arm Adjustment & Tilt Plate & Skid Shoe Adjustment	5
12'-16' Hydraulic Angle - Hydraulic Tilt Blade Assembly	6
10'-16' Hydraulic Angle - No Tilt Blade Assembly	7
Hydraulic Angle - Hydraulic Tilt	8-9
Lift System	10-11
Hydraulic Angle - No Tilt	12
Hydraulic Tilt Hose Routing	13
Hydraulic Angle Hose Routing	14-15
Tractor Side Hydraulics & Lift System Hydraulics	16
Blade Options	17-18
Replacement Wear Parts	19
Hydraulic Schematic	20
Notes	21-23
Contact Us, Improvements, & Warranty	24

Thank you for your recent purchase of a Grouser Ag 240I and 241I Dozer. Welcome to the family of satisfied Grouser blade owners. Grouser Products is committed to offering quality products to help professionals in their daily jobs. We are also committed to providing you the highest level of customer satisfaction possible. Again, thank you for your patronage. We look forward to serving you.

This manual contains information concerning the operation, adjustment, safety and maintenance of the Ag 240I and 241I Dozer. You have purchased a dependable, long lasting piece of equipment. You can expect to receive long lasting performance and long service built into our products with proper care and operation. Please have all operators read and understand this manual carefully. Keep the manual available for reference. If, for any reason, you have questions or comments, we would be happy to hear from you. Call our toll-free number, 800-747-6182, or send us an e-mail at info@grouser.com. You can expect us to respond to your e-mail in a timely manner.

A careful operator is the best operator. Most accidents can be avoided by observing certain precautions. To help prevent accidents, read and take the following precautions before operating this equipment. In addition, please follow all safety and operational instructions of your tractor manufacturer.

The Ag 240I and 241I Dozer:

1. The Ag 240I and 241I Dozer should be operated only by those who are responsible and instructed to do so.
2. Read the owner's manual carefully before using this equipment. Lack of operating knowledge can lead to accidents.
3. Keep the Ag 240I and 241I Dozer maintained in reliable and satisfactory condition to ensure your safety.
4. Make sure the area is clear of people before moving any equipment.
5. Do not modify or permit anyone else to modify or alter the equipment and its components without first consulting Grouser Products.
6. Lower the blade to the ground when not in use.

Servicing the Ag 240I and 241I Dozer:

1. Read and follow all safety instructions provided by the tractor manufacturer.
2. Always use proper personal safety gear when performing maintenance on equipment.
3. Before servicing, relieve hydraulic pressure, stop engine and fully engage parking brake.
4. Escaping hydraulic fluid under pressure can penetrate skin causing serious injury. If fluid is injected into skin, obtain medical attention immediately.
 - DO NOT use your hand to check for leaks. Use a piece of cardboard or paper to search for leaks.
 - Stop the engine and relieve pressure before connecting or disconnecting lines.
 - Tighten all connections before starting the engine or pressurizing lines.

Storing the Ag 240I and 241I:

1. Thoroughly clean the Ag 240I and 241I Dozer before storage. Use paint where necessary to prevent rust.
2. Check the Ag 240I and 241I Dozer for worn or damaged parts. Install new parts as required.
3. Lubricate all pins and joints.

Tighten all bolts to the values listed below unless otherwise noted. Refer to the parts lists for proper length and grade of the bolts.

Size	Torque - Dry (ft-lbs)			
	SAE Grade 5		SAE Grade 8	
	UNC	UNF	UNC	UNF
5/16	17	19	24	27
3/8	30	35	45	50
7/16	50	55	70	80
1/2	75	85	110	120
9/16	110	120	150	170
5/8	150	170	210	240
3/4	260	300	380	420
7/8	430	470	600	670
1	640	720	910	1020

Size	Torque - Dry (ft-lbs)
	Grade 10.9
M18 x 2.50	284
M20 x 2.50	401
M22 x 2.50	547
M24 x 3.00	694

Install undercarriage per the tractor specific mounting instructions.

Due to the harsh environment this equipment operates in, the following tasks should be performed every 10 hours or less.

- Inspect all equipment before operation for existing or potential damage.
- Lubricate all joints with high quality grease.
- Inspect all bolts, and tighten any loose bolts to torque specifications on page 3.
- Check replaceable cutting edge for wear ensuring there is enough material to prevent permanent damage to the Ag 240I and 241I Dozer. For cutting edge information, see pages 19 .
- Check hydraulic cylinders and hoses for damage or leaks. For replacement parts, see hydraulic pages 13-16.
- Make sure all non-rotating pins are secured properly.
- Inspect all decals and order replacement decals from your dealer if any are damaged or worn.
- Inspect all tilt-ways for wear. See page 5 for tilt plate adjustment.
- Replace parts with original parts only.

HAHT	Hydraulic Angle - Hydraulic Tilt
HANT	Hydraulic Angle - No Tilt
NAHT	No Angle - Hydraulic Tilt
NANT	No Angle - No Tilt

1. Verify that the top arm is installed correctly. See the picture of the decal that is on the angle frame below for reference. If you are using a Grouser Hitch, use the lower 2 sets of holes for the top link. If you are using a Factory Hitch, use the upper 2 sets of holes for the top link. Use the color code for the proper pin location.
2. With the blade hooked up, set the blade on the ground. Adjust the top arm until the the center angle pin is vertical and perpendicular to the ground.
3. Carefully run the blade up and down to make sure that the top link doesn't collide with anything.

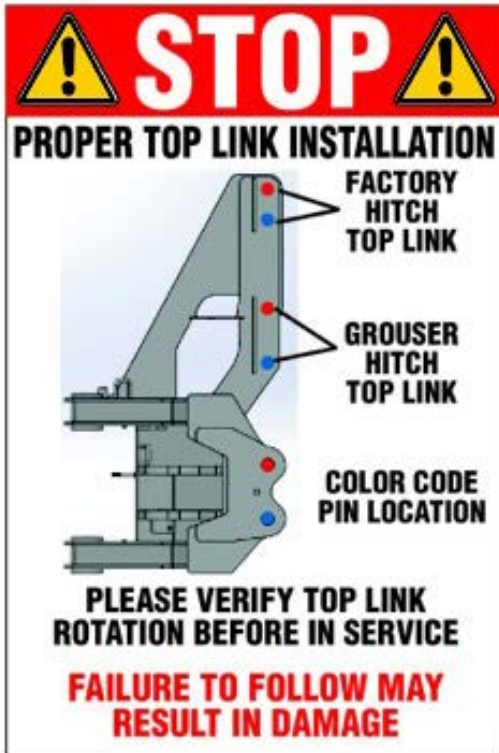

Note: Do not remove all of the bolts at the same time.

1. The preferred blade position for adjusting the tilt plates is laying face down on blocks.
2. Remove the top and bottom bolts from each tilt plate.
3. Add or remove washers as needed to adjust tilt-way clearance to 1/16" - 1/8".
4. Reinstall top and bottom bolts.
5. Follow Steps #2-4 for the center bolts.
6. Once the tilt-way clearance is set, torque bolts to 640 ft-lbs.

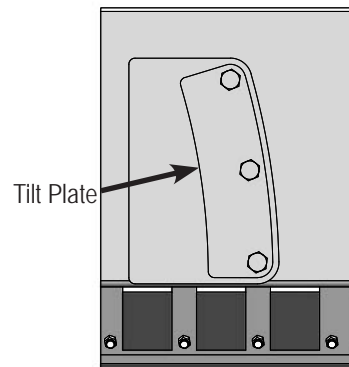

Skid Shoe Adjustment:

1. Pull up on the retractable plunger on the top of the threaded rod to release the handle.
2. Slide the handle out from the locking position on the blade.
3. Turn the handle to adjust the skid shoe to the preferred height.
4. Place the handle back in the hole on the blade and lock in place with the retractable plunger.

12'-16' Hydraulic Angle-Hydraulic Tilt Blade Assembly

ITEM NO.	PART NO.	12' QTY.	14' QTY.	16' QTY.	DESCRIPTION
1	15-41815-12	1	-	-	240 Blade Weld - 12'
1	15-41518-14	-	1	-	240 Blade Weld - 14'
1	15-41815-16	-	-	1	240 Blade Weld - 16'
2	16-20560	6	6	6	1" x 2-1/2" Hex Bolt Gr 8 NC
3	16-20562	1	1	1	1" x 3" Hex Bolt Gr.8 NC
4	16-21064	8	8	8	3/8" x 1" Carriage Bolt Gr 5 NC
5	16-21666	28	30	32	5/8" x 1-3/4" Plow Bolt Gr 5 NC
6	19-7774	1	1	1	1" x 1" Spring Bushing
7	27-17262	1	1	1	Ag 240 Decal
8	27-40962	1	1	1	Warning Prop 65 Decal
9	27-9505	2	2	2	Grouser Vertical Decal
10	NA	1	1	1	Grouser Dozer Metal Serial Tag
11	29-7950-6	2	-	-	Cutting Edge
11	29-7950-7	-	2	-	Cutting Edge
11	29-7950-8	-	-	2	Cutting Edge

ITEM NO.	PART NO.	12' QTY.	14' QTY.	16' QTY.	DESCRIPTION
12	34-40852	2	2	2	Retractable Spring Plunger, 3/8"
13	34-40853	4	4	4	Knob, 1-1/2" Ball
14	34-40859	2	2	2	Spring Clip, 1-3/16"
15	40-40739	2	2	2	Skid Shoe Mount, 240
16	44-15339	1	1	1	Back Drag Plate
17	44-16880	1	1	1	Ag Series Name Plate
18*	44-14830	1	1	1	Custom Name Plate
19	50-15458	2	2	2	12" Round Mushroom Skid Shoe
20	50-40855	2	2	2	Threaded Rod, Skid Shoe
21	50-40857	2	2	2	Handle, Skid Shoe
22	52-8204	2	2	2	240 Tilt Plate
23	57-20749	18	18	18	1" Flat Washer
24	58-9369	2	2	2	Straight 1/8" NPT Grease Zerk
25	70-20622	8	8	8	3/8" Flange Hex Nut Gr 5 NC
26	70-20646	28	30	32	5/8" Hex Top Lock Nut Gr 5 NC

* Part Not Shown

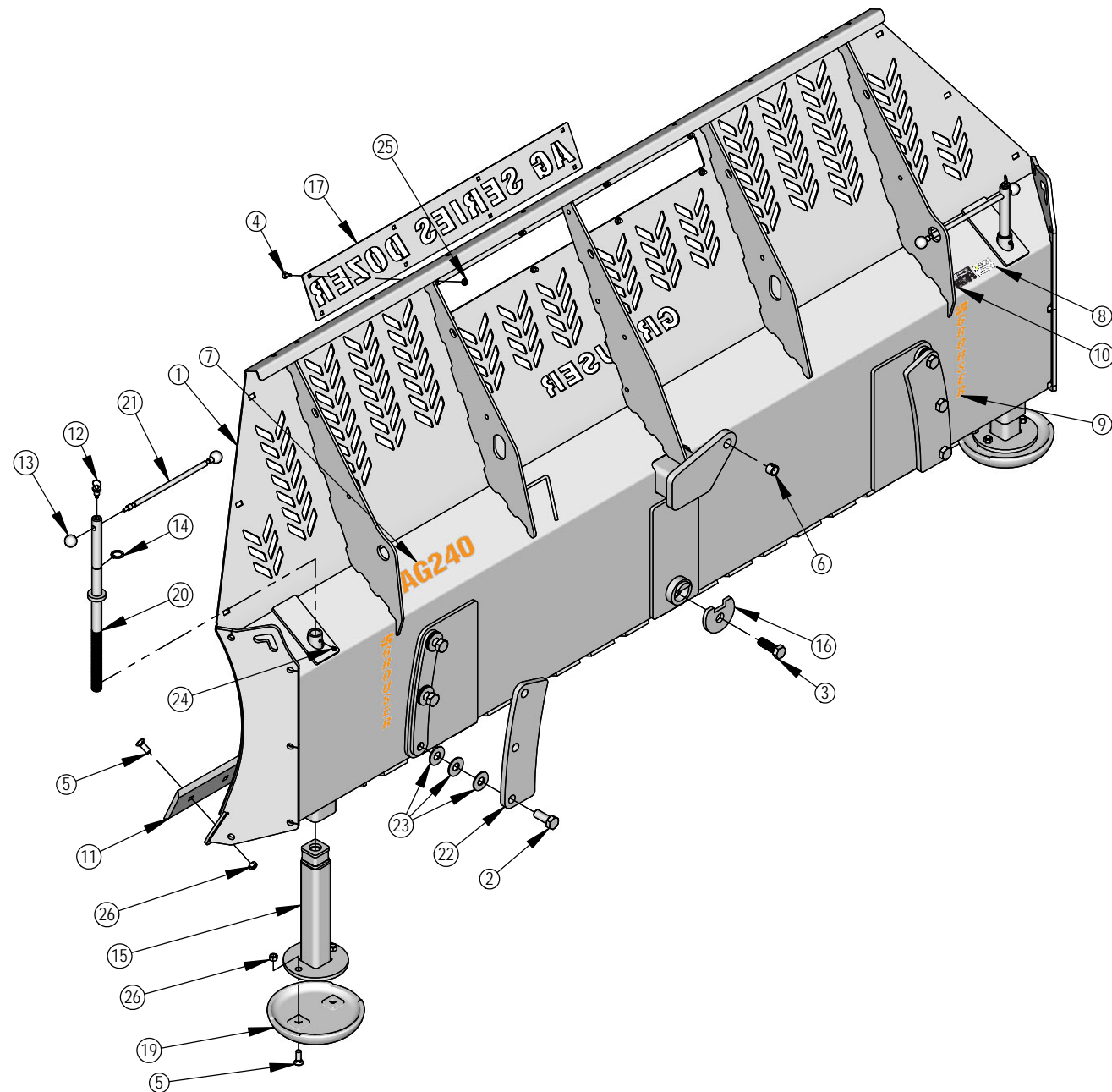

ITEM NO.	PART NO.	10' QTY.	12' QTY.	14' QTY.	16' QTY.	DESCRIPTION
1	15-40860-10	1	-	-	-	240 HANT Blade Weld
1	15-40860-12	-	1	-	-	240 HANT Blade Weld
1	15-40860-14	-	-	1	-	240 HANT Blade Weld
1	15-40860-16	-	-	-	1	240 HANT Blade Weld
2	16-20559	8	8	8	8	1" x 2-1/4" Hex Bolt Gr 8 NC
3	16-21064	8	8	8	8	3/8" x 1" Carriage Bolt Gr 5 NC
4	16-21666	24	28	30	32	5/8" x 1-3/4" Plow Bolt Gr 5 NC
5	17-19800	1	1	1	1	Center Adjustable Mount
6	27-17262	1	1	1	1	Ag 240 Decal
7	27-40962	1	1	1	1	Warning Prop 65 Decal
8	27-9505	2	2	2	2	Grouser Vertical Decal
9	NA	1	1	1	1	Grouser Dozer Metal Serial Tag
10*	29-7950-5	2	-	-	-	Cutting Edge
11	29-7950-6	-	2	-	-	Cutting Edge
11	29-7950-7	-	-	2	-	Cutting Edge
11	29-7950-8	-	-	-	2	Cutting Edge

ITEM NO.	PART NO.	10' QTY.	12' QTY.	14' QTY.	16' QTY.	DESCRIPTION
12	34-40852	2	2	2	2	Retractable Spring Plunger, 3/8"
13	34-40853	4	4	4	4	Knob, 1-1/2" Ball
14	34-40859	2	2	2	2	Spring Clip, 1-3/16"
15	40-40739	2	2	2	2	Skid Shoe Mount, 240
16	44-16880	1	1	1	1	Ag Series Name Plate
17*	44-14830	1	1	1	1	Custom Name Plate
18	50-15458	2	2	2	2	12" Round Mushroom Skid Shoe
19	50-40855	2	2	2	2	Threaded Rod, Skid Shoe
20	50-40857	2	2	2	2	Handle, Skid Shoe
21	57-20819	8	8	8	8	1" Flat Washer Heavy Duty Gr 8
22	58-9369	4	4	4	4	Straight 1/8" NPT Grease Zerk
23	70-20622	8	8	8	8	3/8" Flange Hex Nut Gr 5 NC
24	70-20646	24	28	30	32	5/8" Hex Top Lock Nut Gr 5 NC

* Part Not Shown

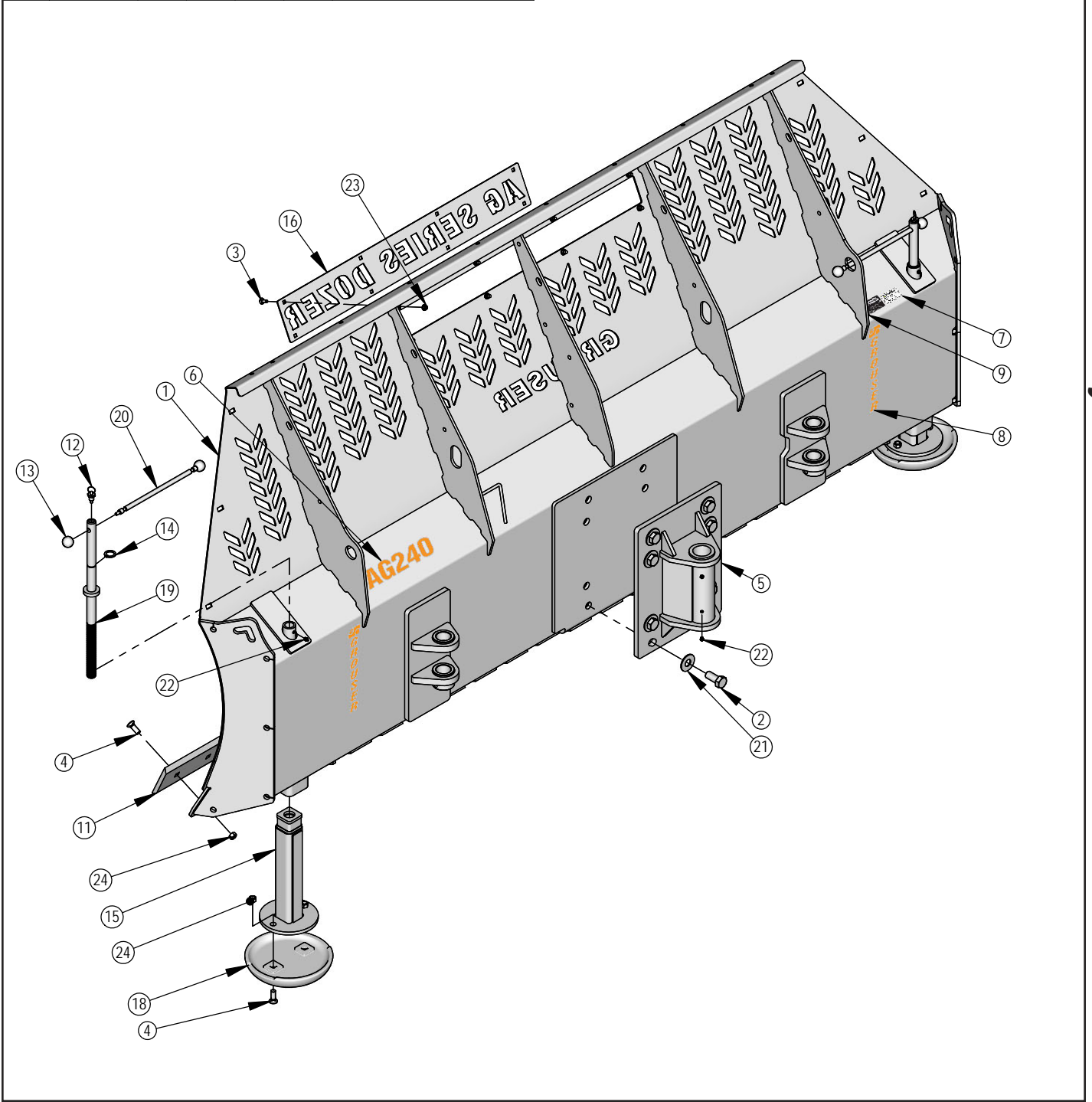

Item #A for Cat 2
 Item #B for Cat 3N
 Item #C for 241 System
 * Parts Not Shown

Item No.	Qty.	Part No.	Description
1	2	16-20034	5/16" x 1" Hex Bolt Gr 5 NC
2	4	16-20134	1/2" x 3-1/2" Hex Bolt Gr 5 NC
3	2	16-20216	3/4" x 1-1/2" Hex Bolt Gr 5 NC
4	1	16-20558	1" x 2" Hex Bolt Gr 8 NC
5	2	16-35C612	3/8" x 3/4" Flanged Bolt
6	2	16-13577	NR Pin Spacer Clevis End
7	2	19-13515	3/4" ID Non Rotating Pin Spacers
8	1	19-7774	1"x1" Spring Bushing
9A	2	19-7774	1" x 1" Spring Bushing
10C*	2	22-8813	Quick Claw Uni Ball
11	1	26-34711	4 x 8 Cylinder w/ Cast Clevis Ends (647134)
12	2	26-34748	5 x 12 Cylinder Tube Ends (658378)
13	1	32-18400	Tilt Frame
14	1	34-14961	Manual Canister
15A	1	43-11665	Top Link Pin - Cat 2
16	2	43-13580	1" Clevis Bolt in Pin
17	1	43-16764	7/16" x 1-3/4" Lynch Pin
18	4	43-18405	Cylinder Pin
19	1	43-16925	Angle Pin
20	1	43-3287	Top Link Pin - Cat 3N
21	2	43-3289	Lower Lift Pin
22	1	45-18420	ISO Angle Frame
23	1	57-16928	3.50" OD x 1.06" ID Washer
24	4	57-20741	5/16" Flat Washer
25	2	57-20747	3/4" Flat Washer
26	4	58-9369	Grease Zerk 1/8" NPT Straight
27	1	58-9369	Grease Zerk 1/8" NPT 45°
28	4	70-20604	1/2" Hex Center Lock Nut NC
29	2	70-20611	5/16" Nyloc Nut

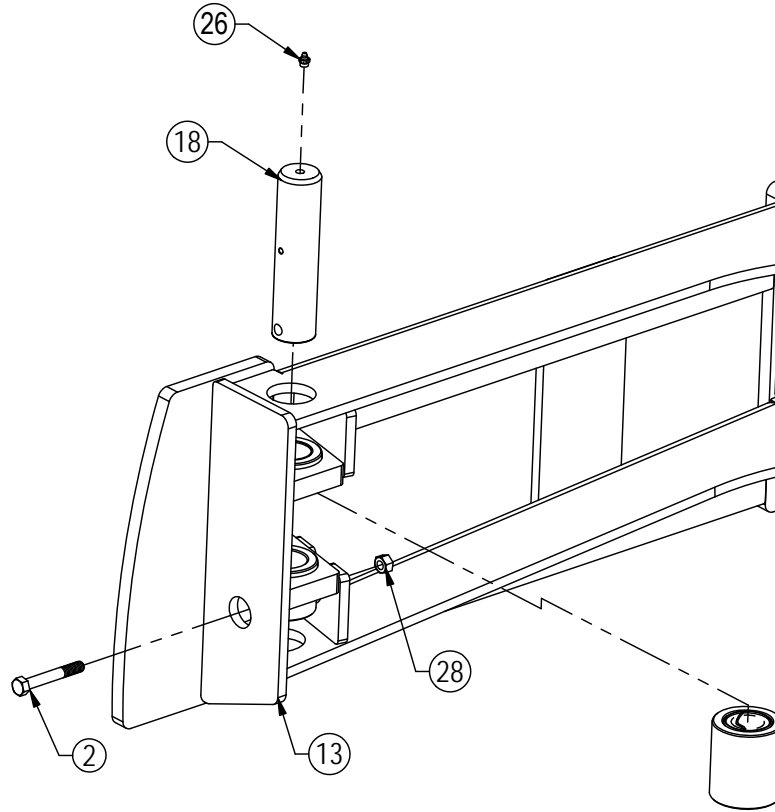

NOTE: When ordering cylinder seal kits, the part number on the cylinder is needed. The number is stamped on the base end of the cylinder opposite of the hydraulic ports.

No. On Cylinder	Part No.	Description
26-34748	49-12272	Monarch Seal Kit 5 x 12 (649246) Nitrided Rod
26-34711	49-12271	Seal Kit 4 x 8 (647135) Nitrided Rod, Clevis Ends

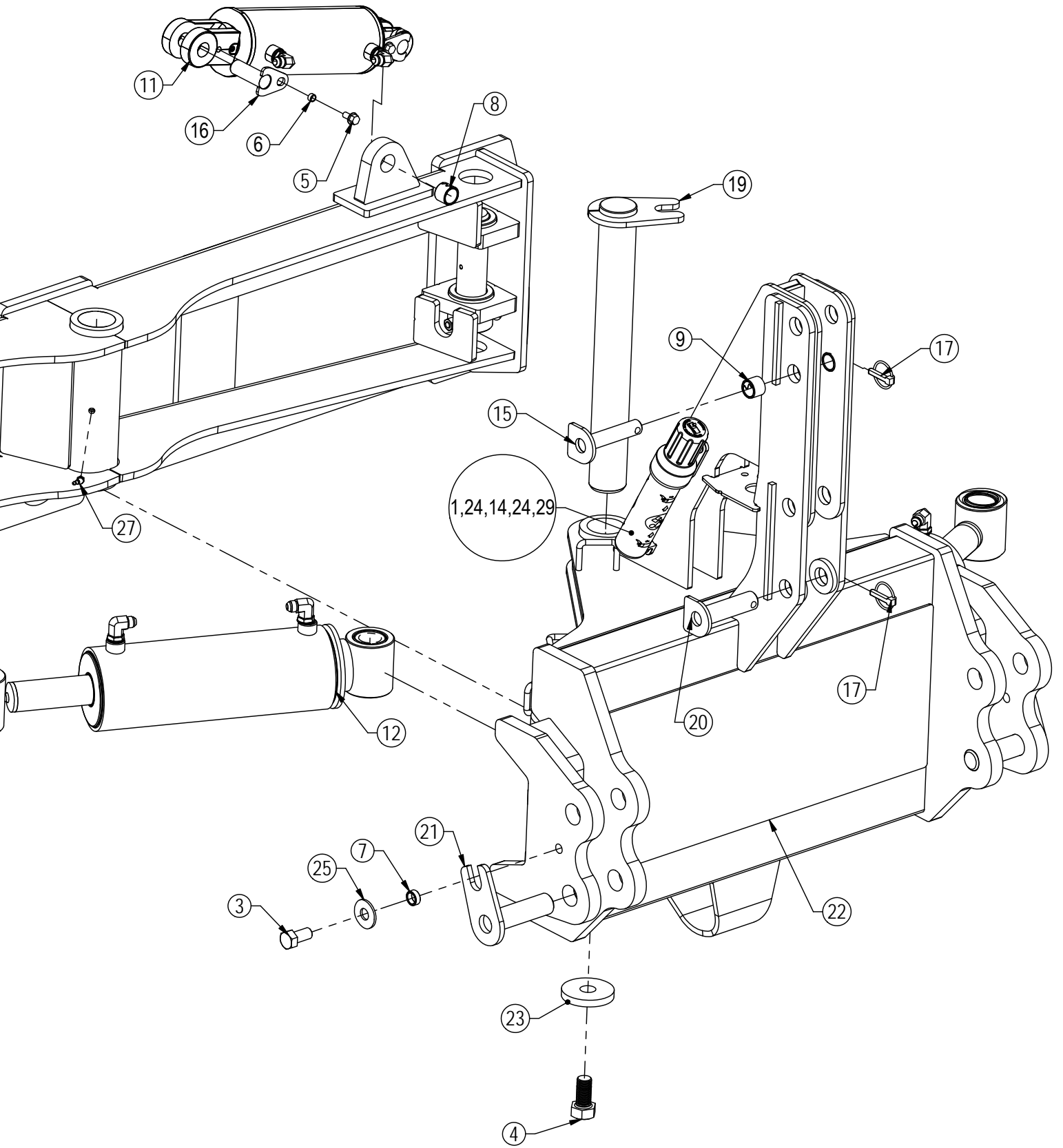

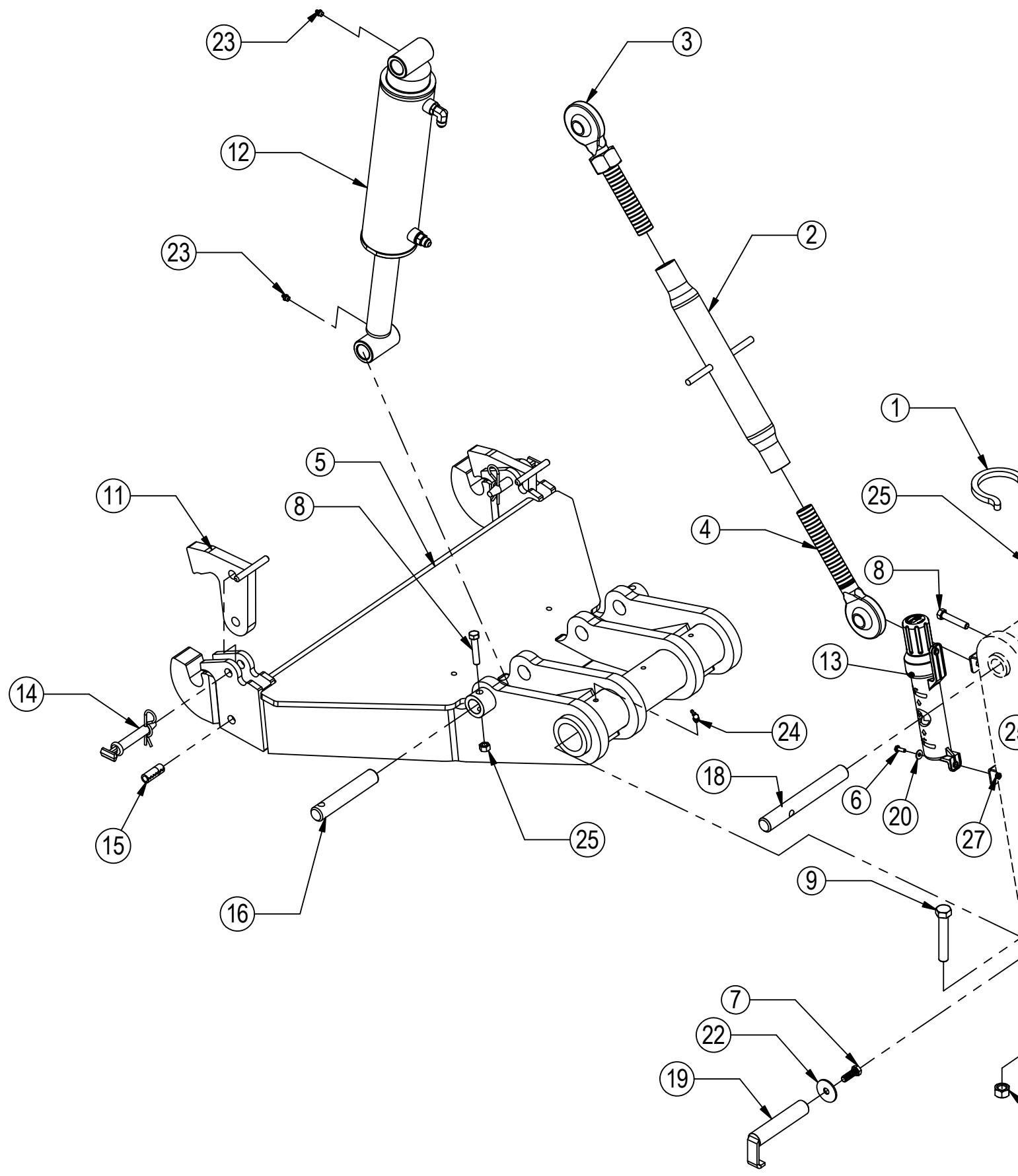

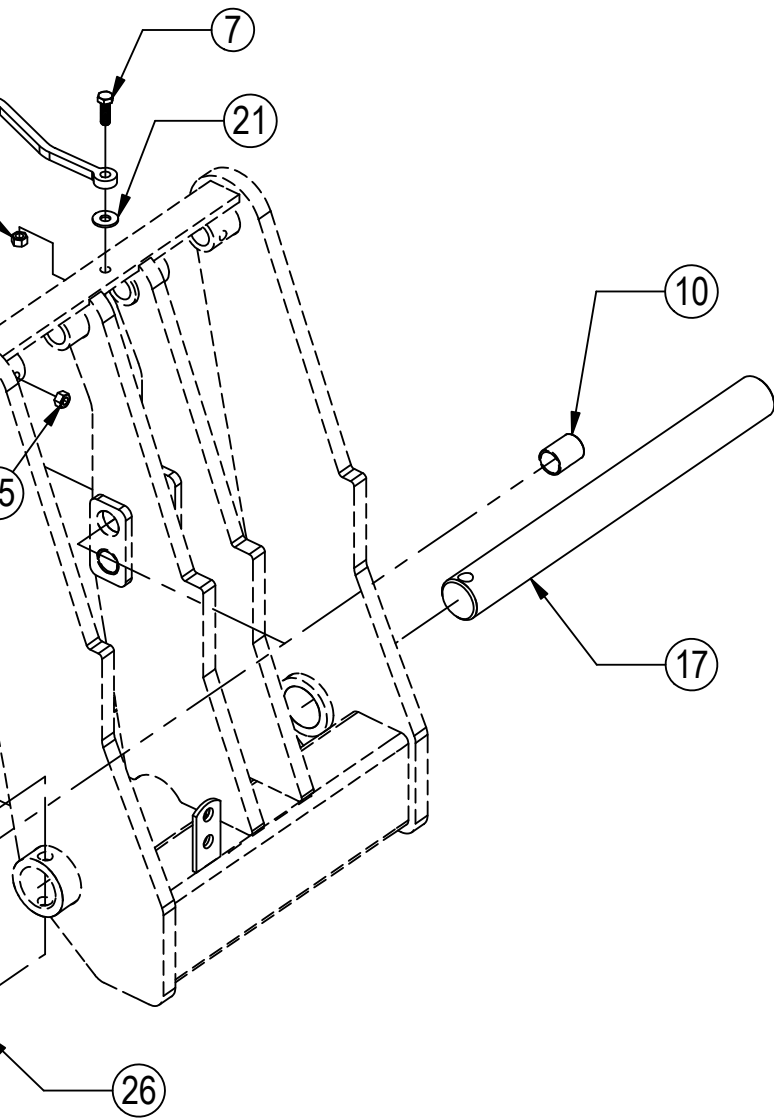

Item No.	Qty.	Part No.	Description
1	1	11-1455	FH-400 Top Arm Hook
2,3,4	1	11-11135	FH-400 Pitch Control Top Arm Link
2	1	11-11137	FH-400 Pitch Control Arm Housing
3	1	11-11136RH	FH-400 Pitch Control Arm Screw Assy- Right Hand
4	1	11-11136LH	FH-400 Pitch Control Arm Screw Assy - Left Hand
5	1	11-15710	FH-400 Solid Lower Arm - V2
6	2	16-20002	1/4" x 3/4" Hex Bolt Gr 5 NC
7	2	16-20126	1/2" x 1-1/2" Hex Bolt Gr 5 NC
8	4	16-20130	1/2" x 2-1/2" Hex Bolt Gr 5 NC
9	1	16-20227	3/4" x 4-1/2" Hex Bolt Gr 5 NC
10	4	19-3774	1.5"x1.25"x2.00" Spring Bushing (150125200)
11	2	22-15701	FH-400 Solid Lower Arm Latch
12	2	26-34728	4 x 12 Cylinder Tube Ends
13	1	34-14961	Manual Canister
14	2	43-15712	3/4" x 3-1/4" Safety Hitch Pin
15	2	43-17905	3/4" x 1/2" x 2" Spring Pin
16	2	43-8234	Rod End Lift Cylinder Pin (1-1/4" x 7.25")
17	1	43-8322	Main Lift Arm Pin (2-7/16" x 25")
18	2	43-9334	Base Cylinder Pin (1-1/4" x 10.03")
19	1	43-11471	Top Arm/UC Pin
20	2	57-20740	1/4" Flat Washer
21	1	57-20744	1/2" Flat Washer
22	1	57-20794	1/2" Fender Washer (2.00" ODx .500"ID x .125")
23	4	58-9369	Grease Zerk 1/8" NPT Straight
24	3	58-9371	Grease Zerk 1/8" NPT 45°
25	5	70-20604	1/2" Hex Center Lock Nut Gr 2 NC
26	1	70-20607	3/4" Hex Center Lock Nut Gr 2 NC
27	2	70-20610	1/4" Nyloc Hex Nut Gr 5 NC

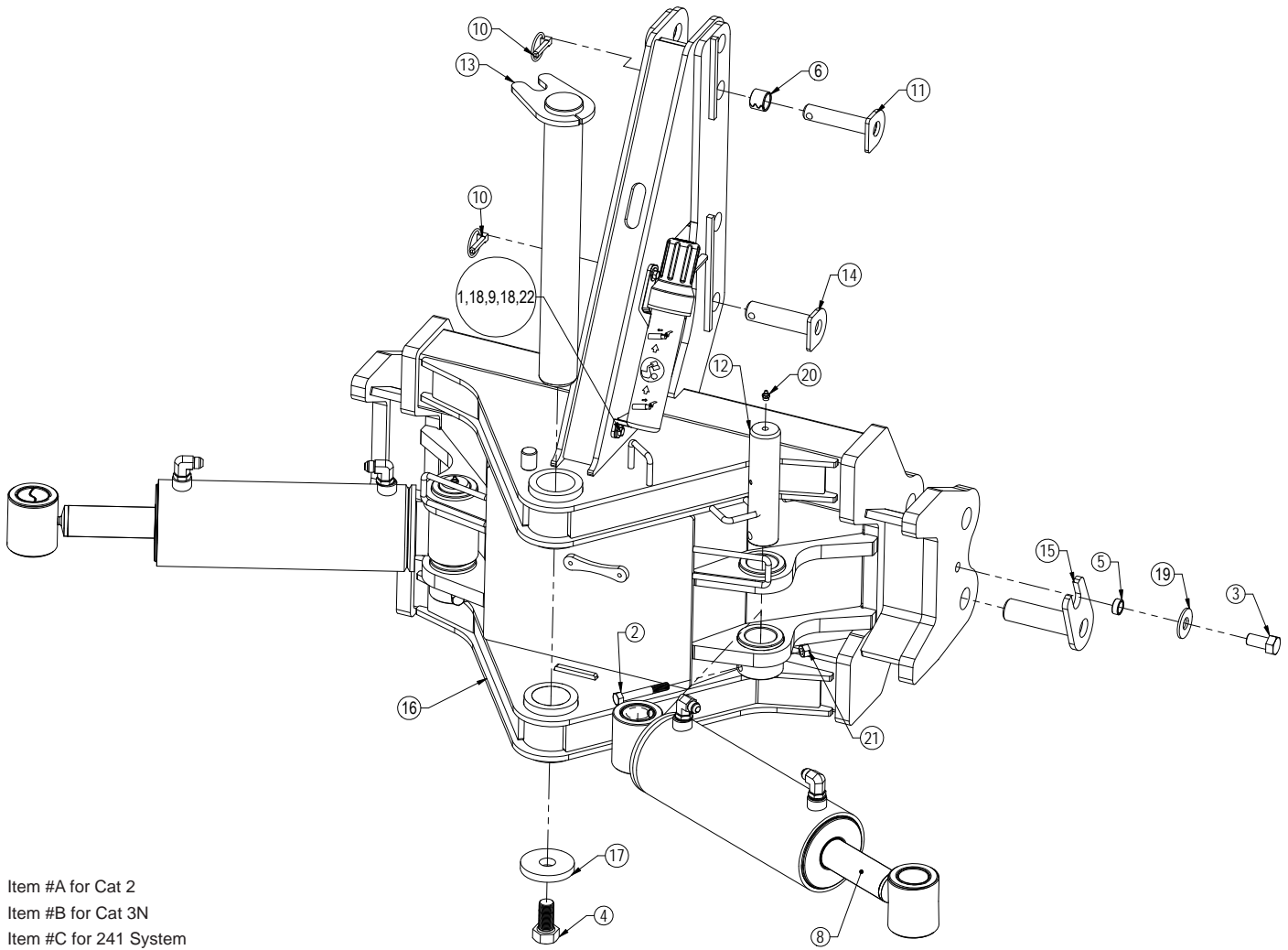

Item #A for Cat 2
 Item #B for Cat 3N
 Item #C for 241 System
 * Parts Not Shown

Item No.	Qty.	Part No.	Description
1	2	16-20034	5/16" x 1" Hex Bolt Gr 5 NC
2	2	16-20134	1/2" x 3-1/2" Hex Bolt Gr 5 NC
3	2	16-20216	3/4" x 1-1/2" Hex Bolt Gr 5 NC
4	1	16-20558	1" x 2" Hex Bolt Gr 8 NC
5	2	19-13515	3/4" ID Non Rotating Pin Spacers
6A	2	19-7774	1" x 1" Spring Bushing
7C*	2	22-8813	Quick Claw Uni Ball
8	2	26-34748	5 x 12 Cylinder Tube Ends (658378)
9	1	34-14961	Manual Canister
10	1	43-16764	7/16" x 1-3/4" Lynch Pin
11A	1	43-11665	Top Link Pin - Cat 2
12	2	43-18405	Cylinder Pin
13	1	43-16925	Angle Pin
14B	1	43-3287	Top Link Pin - Cat 3N
15	2	43-3289	Lower Lift Pin
16	1	45-18420	ISO Angle Frame
17	1	57-16928	3.50" OD x 1.06" ID Washer
18	4	57-20741	5/16" Flat Washer
19	2	57-20747	3/4" Flat Washer
20	2	58-9369	Grease Zerk 1/8" NPT Straight
21	2	70-20604	1/2" Hex Center Lock Nut NC
22	2	70-20611	5/16" Nyloc Hex Nut

NOTE: When ordering cylinder seal kits, the part number on the cylinder is needed. The number is stamped on the base end of the cylinder opposite of the hydraulic ports.

No. On Cylinder	Part No.	Description
26-34748	49-12272	Monarch Seal Kit 5 x 12 (649246) Nitrided Rod

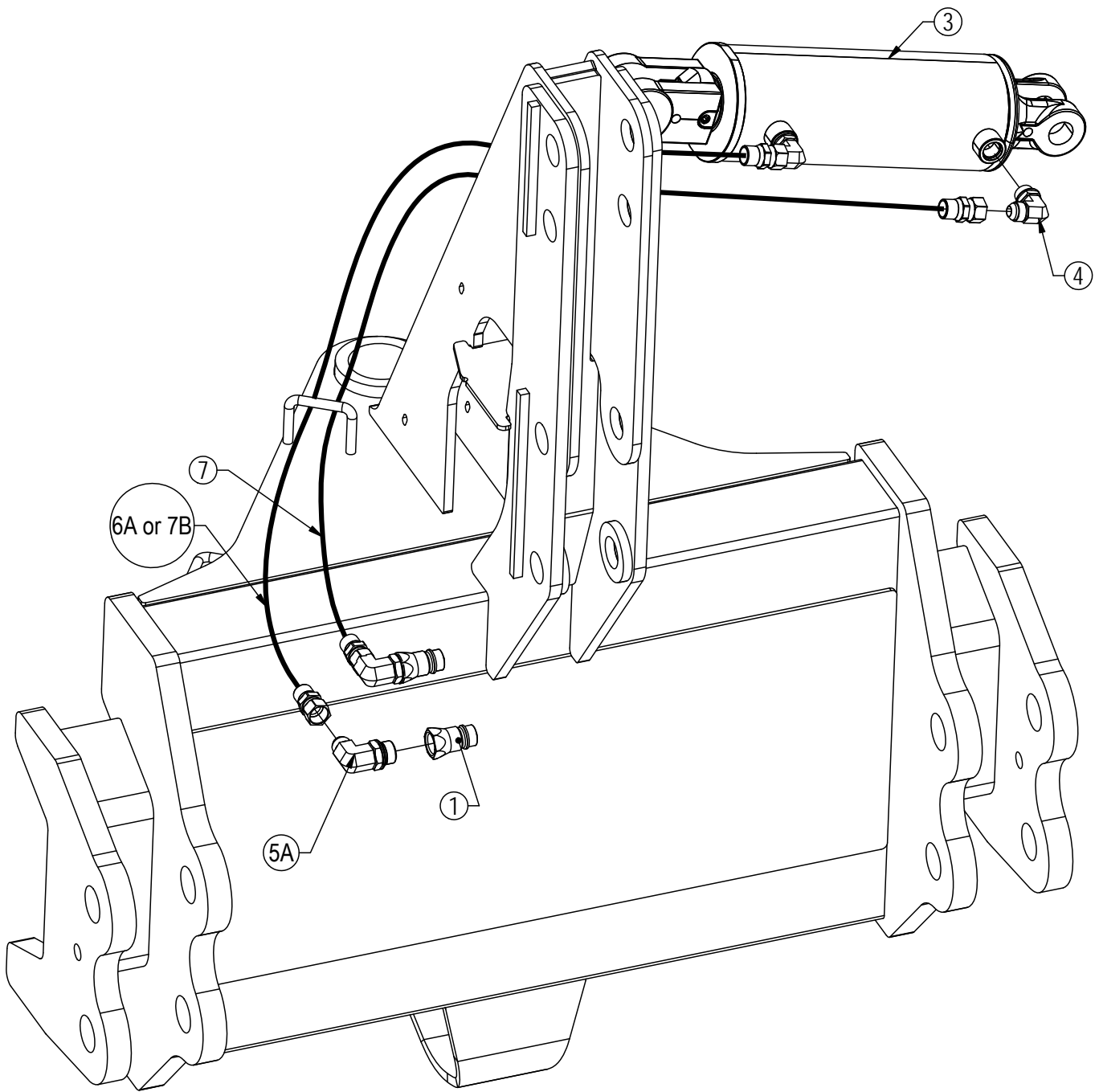

Item #A for 240 System

Item #B for 241 System

* Parts Not Shown

Hoses Not Drawn To Scale

Item No.	Qty.	Part No.	Description
1	2	25-34342	Tappet Quick Coupler - Male
2*	2	25-3453	Pioneer Dust Cap Tilt (Green)
3	1	26-34711	4 x 8 Cylinder W/ Cast Clevis Ends
4	2	31-34050	Straight Thread Elbow 90° JIC x O-Ring (6801-8-8)
5A	2	31-34051	Straight Thread Elbow 90° JIC x O-Ring (6801-8-10)
6A	1	35-31030	63" x 3/8" -8 JIC/-8 JIC Hose w/ Cordura (4M)
7A	1	35-31032	69" x 3/8" -8 JIC/-8 JIC Hose w/ Cordura (4M)
7B	2	35-31244	105" x 3/8" -8 JIC/-10 MB Hose w/ Cordura (4M)

See Pages 14-16 for the remaining hydraulics.

See Page 20 for hydraulic schematic.

NOTE: When ordering cylinder seal kits, the part number on the cylinder is needed. The number is stamped on the base end of the cylinder opposite of the hydraulic ports.

No. On Cylinder	Part No.	Description
26-34711	49-12271	Seal Kit 4 x 8 (647135) Nitrided Rod, Clevis Ends

Hoses Not Drawn To Scale

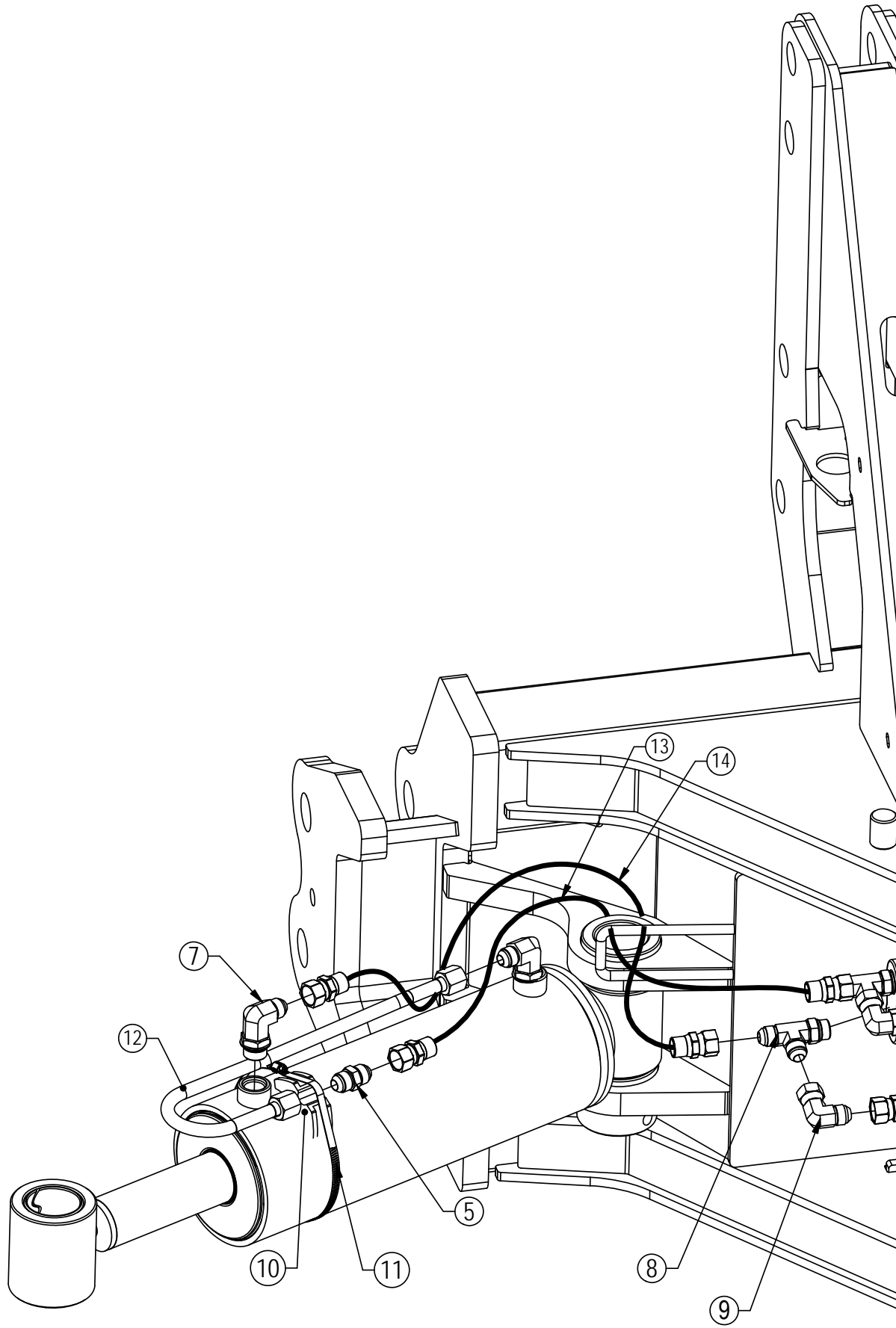

Item No.	Qty.	Part No.	Description
1	2	16-20040	5/16" X 2 1/2 " Hex Bolt Gr 5 NC
2	2	25-34342	Tappet Quick Coupler - Male
3*	2	25-3455	Pioneer Dust Cap Angle (Red)
4	2	26-34748	5 x 12 Cylinder W/ Tube Ends
5	2	31-11699-8-8	JIC Union (2403-8-)
6	2	31-34040	Straight JIC x O-Ring (6400-8-8)
7A	6	31-34051	Straight Thread Elbow 90° JIC x O-Ring (6801-8-10)
7B	4	31-34051	Straight Thread Elbow 90° JIC x O-Ring (6801-8-10)
8	2	31-34070	Run Tee JIC x O-Ring (6804-8-8-8)
9	2	31-34100	Swivel Nut Elbow 90° JIC (6500-8-8)
10	2	34-12932	Cylinder Saddle
11	2	34-12933	Hose Clamp (SAE 96)
12	2	35-17260	240 Formed Steel Line
13	2	35-31010	25" x 3/8" -8 JIC/-8 JIC Hose w/ Cordura (4M)
14	2	35-31013	28" x 3/8" -8 JIC/-8 JIC Hose w/ Cordura (4M)
15A	2	35-31030	63" x 3/8" -8 JIC/-8 JIC Hose w/ Cordura (4M)
15B	2	35-31244	105" x 3/8" -8 JIC/-10 MB Hose w/ Cordura (4M)
16	1	56-7772	Relief Valve

Item #A for 240 System
 Item #B for 241 System
 * Parts Not Shown

See Pages 13 and 16 for the remaining hydraulics.
 See Page 20 for hydraulic schematic.

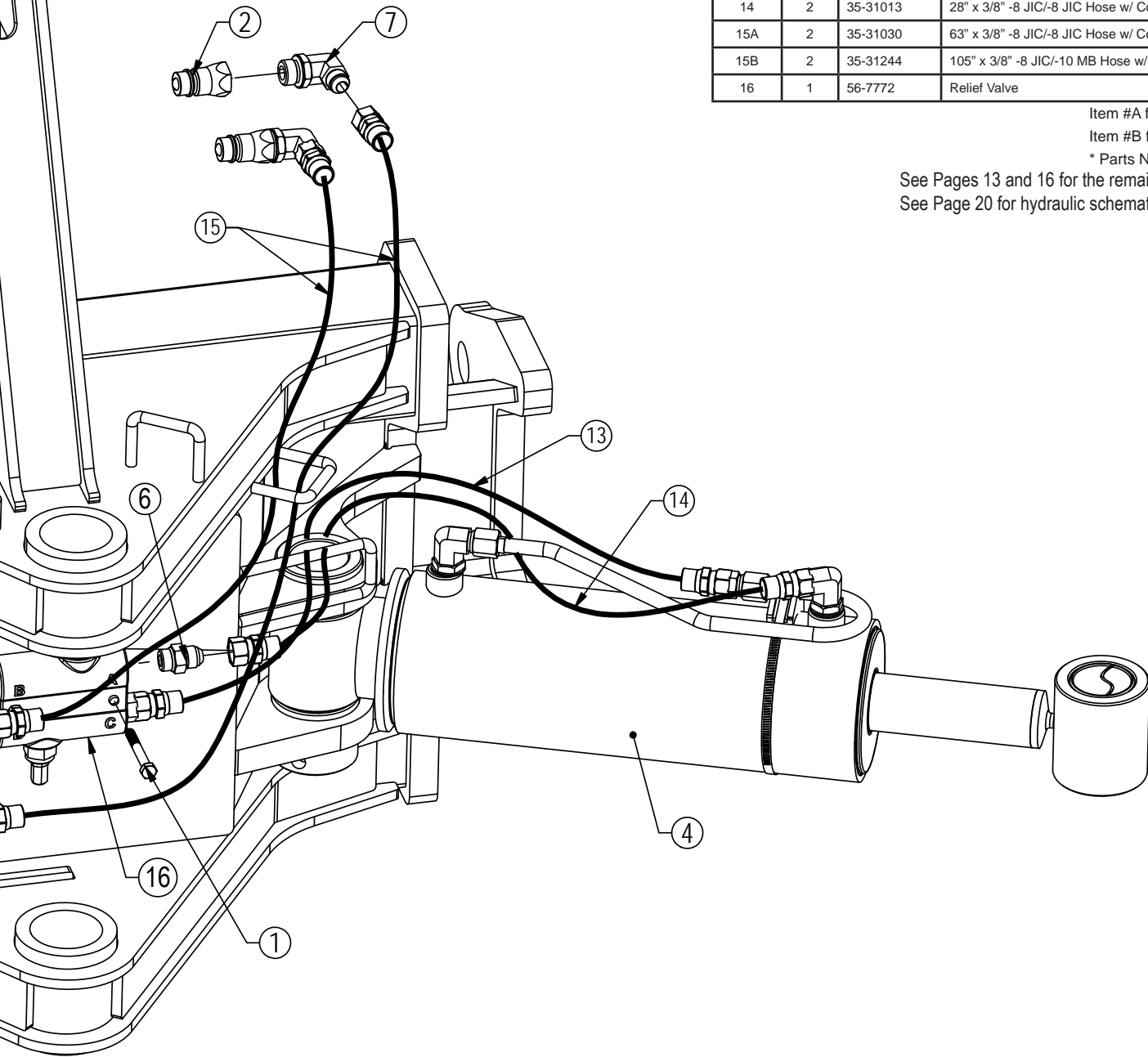

NOTE: When ordering cylinder seal kits, the part number on the cylinder is needed. The number is stamped on the base end of the cylinder opposite of the hydraulic ports.

No. On Cylinder	Part No.	Description
26-34748	49-12272	Monarch Seal Kit 5 x 12 (649246) Nitrided Rod

Item No.	Part No.	Description	HAHT Qty.	HANT Qty.
1	16-20126	1/2" x 1-1/2" Hex Bolt Gr 5 NC	2	1
2	18-8973	Coupler Mounting Bracket	2	1
3	25-34321	Tappet Quick Coupler Female	4	2
4	25-34342	Tappet Quick Coupler - Male	4	2
5*	25-3453	Pioneer Dust Cap Tilt (Green)	2	-
6*	25-3454	Pioneer Dust Plug Tilt (Green)	2	-
7*	25-3455	Pioneer Dust Cap Angle (Red)	2	2
8*	25-3456	Pioneer Dust Plug Angle (Red)	2	2
9	31-34051	Straight Thread Elbow 90° JIC x O-Ring (6801-8-10)	4	2

* Parts Not Shown
Hoses Not Drawn to Scale

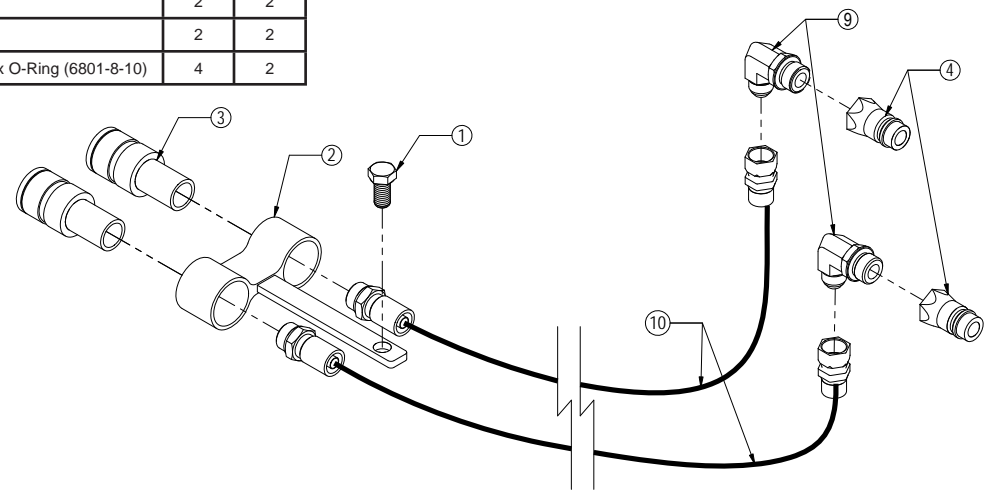

See Page 20 for hydraulic schematic.

Item No.	Qty.	Part No.	Description
1	2	25-34342	Tappet Quick Coupler - Male
2*	2	25-3457	Pioneer Dust Cap Lift (Orange)
3	2	26-34728	4 x 12 Cylinder W/ Tube Ends
4	2	31-34040	Straight JIC x O-Ring (6400-8-8)
5	2	31-34050	Straight Thread Elbow 90° JIC x O-Ring (6801-8-8)
6	2	31-34051	Straight Thread Elbow 90° JIC x O-Ring (6801-8-10)
7A	2	31-34030	Bulkhead Run Tee JIC (2704-8-8-8)
7B	2	31-34020	Bulkhead Branch Tee JIC (2703-8-8-8)
8	2	70-20807	3/4" Hex Jam Nut NF

Item #A for 240 System
Item #B for 241 System
* Parts Not Shown
Hoses Not Drawn To Scale

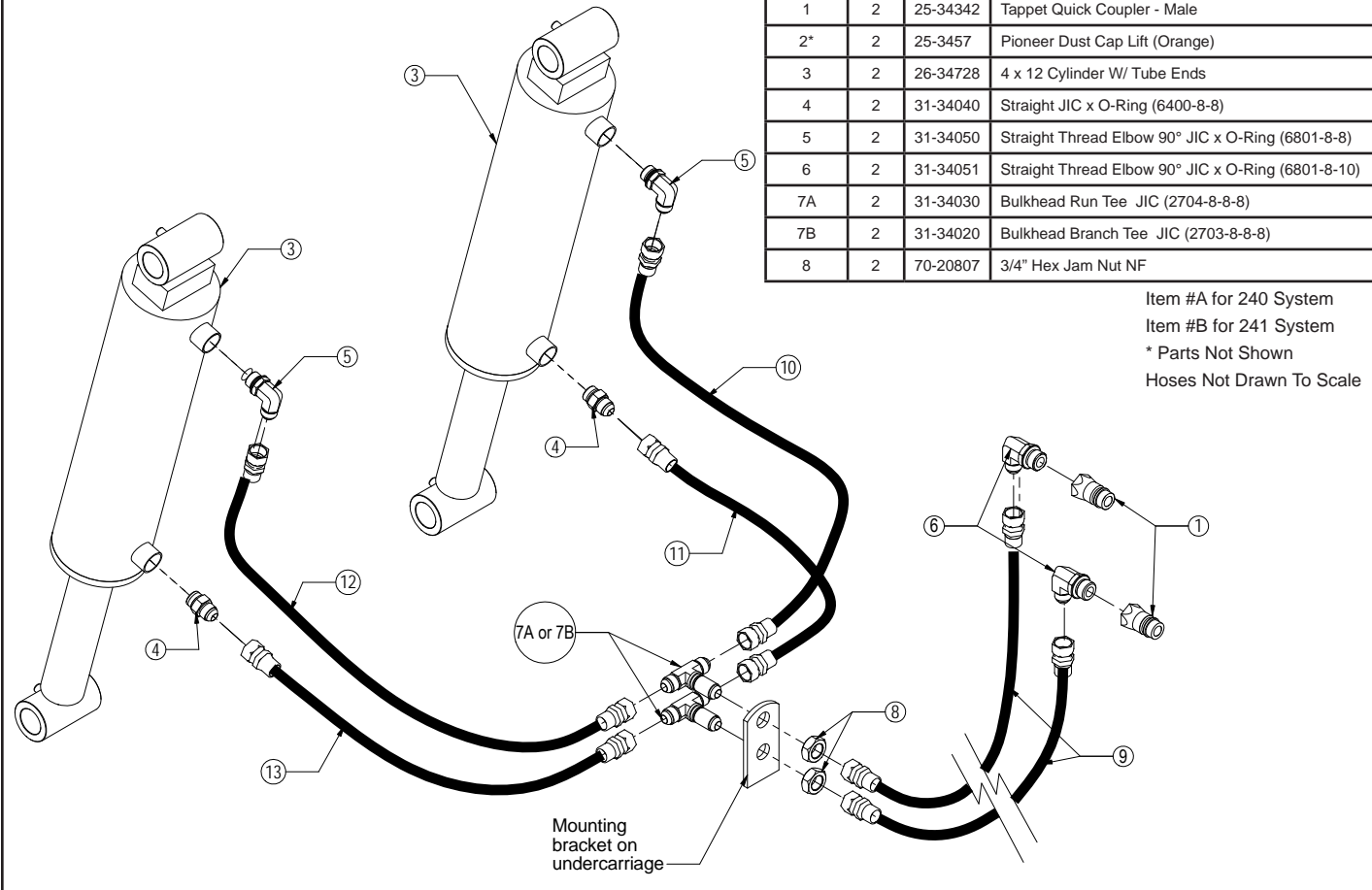

NOTE: When ordering cylinder seal kits, the part number on the cylinder is needed. The number is stamped on the base end of the cylinder opposite of the hydraulic ports.

No. On Cylinder	Part No.	Description
26-34728	49-12272	Seal Kit 4 x 2 (647204) Nitrided Rod

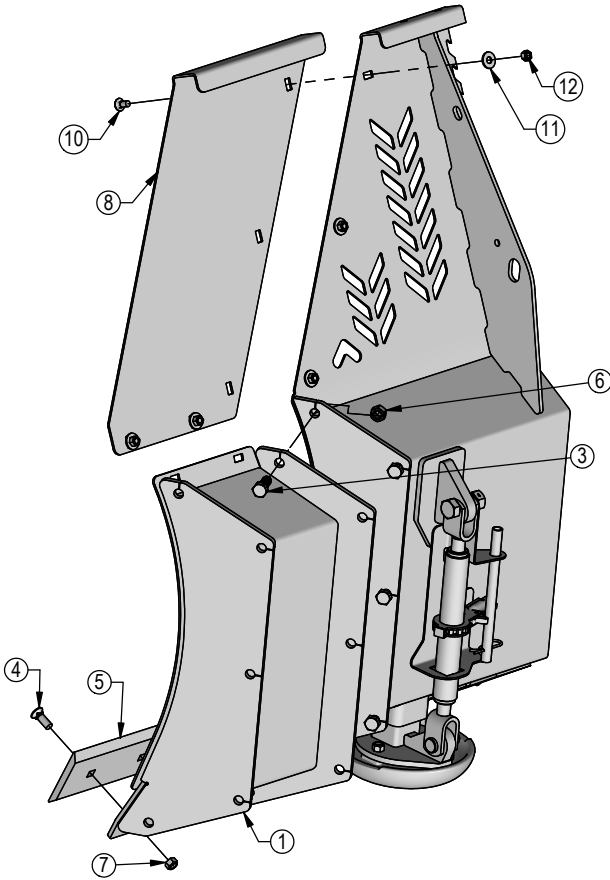

240 - 1' End Extension Kit - 17525-1-A

Item	Qty.	Part No.	Description
1	1	15-17525-1-L	1' End Extension - Left
2*	1	15-17525-1-R	1' End Extension - Right
3	10	16-20218	3/4" x 2" Hex Bolt Gr 5 NC
4	4	16-21666	5/8" x 1-3/4" Plow Bolt Gr 5 NC
5	2	29-7950-1	1'- 5/8" x 6" Double Bevel Cutting Edge
6	10	70-20607	3/4" Hex Center Lock Nut Gr 2 NC
7	4	70-20646	5/8" Hex Top Lock Nut Gr 5 NC

240 - 1' End Extension Top Extension Kit - 19215-K

Item	Qty.	Part No.	Description
8	1	15-19215-L	240 1' End Extension Top Extension - Left
9*	1	15-19215-R	240 1' End Extension Top Extension - Right
10	10	16-21124	1/2" x 1" Carriage Bolt Gr 5 NC
11	10	57-20744	1/2" Flat Washer
12	10	70-20604	1/2" Hex Center Lock Nut Gr 2 NC

240 - 2' End Extension Kit - 17525-2-A

Item	Qty.	Part No.	Description
1*	1	15-17525-2-L	2' End Extension - Left
2*	1	15-17525-2-R	2' End Extension - Right
3	10	16-20218	3/4" x 2" Hex Bolt Gr 5 NC
4	8	16-21666	5/8" x 1-3/4" Plow Bolt Gr 5 NC
5*	2	29-7950-2	2'- 5/8" x 6" Double Bevel Cutting Edge
6	10	70-20607	3/4" Hex Center Lock Nut Gr 2 NC
7	8	70-20646	5/8" Hex Top Lock Nut Gr 5 NC

240 - 2' End Extension Top Extension Kit - 19216-K

Item	Qty.	Part No.	Description
8*	1	15-19216-L	240 2' End Extension Top Extension - Left
9*	1	15-19216-R	240 2' End Extension Top Extension - Right
10	12	16-21124	1/2" x 1" Carriage Bolt Gr 5 NC
11	12	57-20744	1/2" Flat Washer
12	12	70-20604	1/2" Hex Center Lock Nut Gr 2 NC

* Parts Not Shown

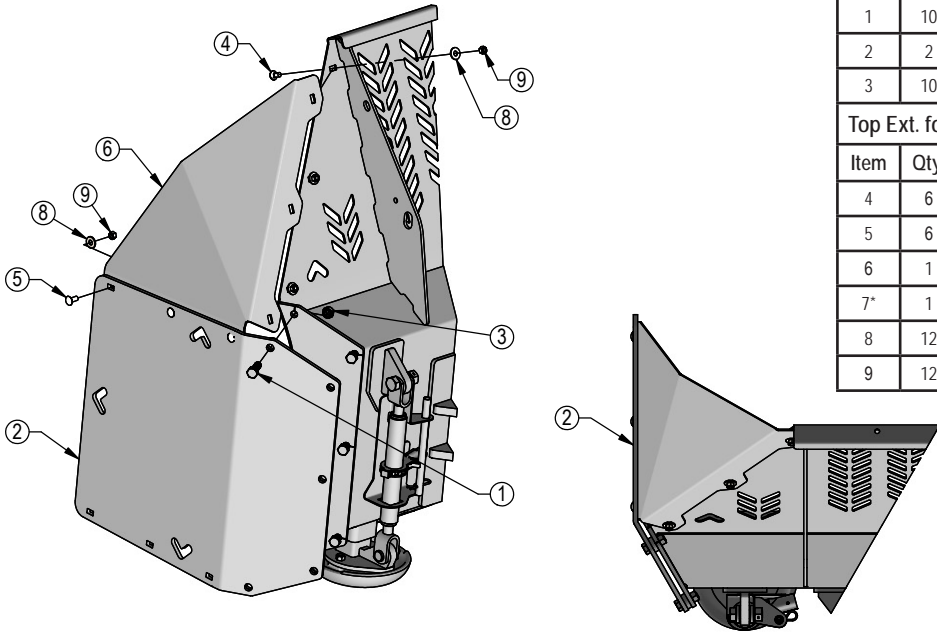

240 Box End Plates - 19350-K

Item	Qty.	Part No.	Description
1	10	16-20219	3/4" x 2-1/4" Hex Bolt Gr 5 NC
2	2	44-19350	240 - 1/2" Bent End Plates (Std Straight)
3	10	70-20607	3/4" Hex Center Lock Nut Gr 2 NC

Top Ext. for Box End Plates - 19351-K

Item	Qty.	Part No.	Description
4	6	16-21124	1/2" x 1" Carriage Bolt Gr 5 NC
5	6	16-21125	1/2" x 1-1/4" Carriage Bolt Gr 5 NC
6	1	44-19351-L	240 - Top Ext for Box End Plates - Left
7*	1	44-19351-R	240 - Top Ext for Box End Plates - Right
8	12	57-20744	1/2" Flat Washer
9	12	70-20604	1/2" Hex Center Lock Nut Gr 2 NC

* Parts Not Shown

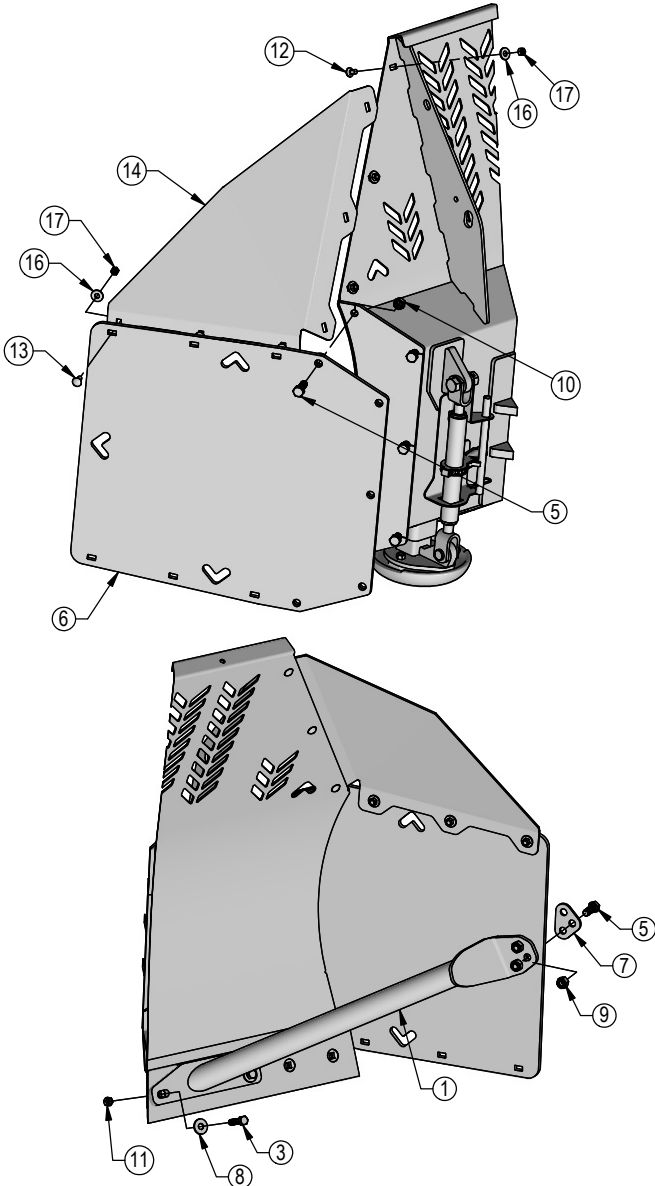

240 U-End Plates (U-End) - 19349-K

Item	Qty.	Part No.	Description
1	1	11-18640-L	240 - U-End Plate Brace - Left
2*	1	11-18640-R	240 - U-End Plate Brace - Right
3	4	16-20190	5/8" x 2 1/2" Hex Bolt Gr 5 NC
4	10	16-20219	3/4" x 2-1/4" Hex Bolt Gr 5 NC
5	6	16-20508	3/4" x 2" Hex Bolt Gr 8 NC
6	2	44-19349	240 - 1/2" Box End Plates (U-End)
7	2	44-18645	Lift Hook Washer
8	4	57-20816	5/8" Flat Washer Grade 8 (USS)
9	6	70-20597	3/4" Hex Nut Gr 8 NC
10	10	70-20607	3/4" Hex Center Lock Nut Gr 2 NC
11	4	70-20646	5/8" Hex Top Lock Nut Gr 5 NC

Top Ext. for U-End Plates - 19348-K

Item	Qty.	Part No.	Description
12	6	16-21124	1/2" x 1" Carriage Bolt Gr 5 NC
13	6	16-21125	1/2" x 1-1/4" Carriage Bolt Gr 5 NC
14	1	44-19348-L	240 - Top Ext for U-End Plates - Left
15*	1	44-19348-R	240 - Top Ext for U-End Plates - Right
16	12	57-20744	1/2" Flat Washer
17	12	70-20604	1/2" Hex Center Lock Nut Gr 2 NC

* Parts Not Shown

1' - 5/8" x 6" Cutting Edge w/ Hardware Kit - 7950-1K

Item	Qty.	Part No.	Description
1	2	16-21666	5/8" x 1-3/4" Plow Bolt Gr 5 NC
2	1	29-7950-1	1' - 5/8" x 6" Double Bevel Cutting Edge
3	2	70-20646	5/8" Hex Top Lock Nut Gr 5 NC

2' - 5/8" x 6" Cutting Edge w/ Hardware Kit - 7950-2K

Item	Qty.	Part No.	Description
1	4	16-21666	5/8" x 1-3/4" Plow Bolt Gr 5 NC
2	1	29-7950-2	2' - 5/8" x 6" Double Bevel Cutting Edge
3	2	70-20646	5/8" Hex Top Lock Nut Gr 5 NC

5' - 5/8" x 6" Cutting Edge w/ Hardware Kit - 7950-5K

Item	Qty.	Part No.	Description
1	10	16-21666	5/8" x 1-3/4" Plow Bolt Gr 5 NC
2	1	29-7950-5	5' - 5/8" x 6" Double Bevel Cutting Edge
3	10	70-20646	5/8" Hex Top Lock Nut Gr 5 NC

6' - 5/8" x 6" Cutting Edge w/ Hardware Kit - 7950-6K

Item	Qty.	Part No.	Description
1	12	16-21666	5/8" x 1-3/4" Plow Bolt Gr 5 NC
2	1	29-7950-6	6' - 5/8" x 6" Double Bevel Cutting Edge
3	12	70-20646	5/8" Hex Top Lock Nut Gr 5 NC

7' - 5/8" x 6" Cutting Edge w/ Hardware Kit - 7950-7K

Item	Qty.	Part No.	Description
1	12	16-21666	5/8" x 1-3/4" Plow Bolt Gr 5 NC
2	1	29-7950-7	7' - 5/8" x 6" Double Bevel Cutting Edge
3	14	70-20646	5/8" Hex Top Lock Nut Gr 5 NC

8' - 5/8" x 6" Cutting Edge w/ Hardware Kit - 7950-8K

Item	Qty.	Part No.	Description
1	16	16-21666	5/8" x 1-3/4" Plow Bolt Gr 5 NC
2	1	29-7950-1	1' - 5/8" x 6" Double Bevel Cutting Edge
3	16	70-20646	5/8" Hex Top Lock Nut Gr 5 NC

12" Round Mushroom Skid Shoe Kit (12'-16' Blades) - 15458-K

Item	Qty.	Part No.	Description
4	4	16-21666	5/8" x 1-3/4" Plow Bolt Gr 5 NC
5	2	50-15458	12" Round Mushroom Skid Shoe
6	4	70-20646	5/8" Hex Top Lock Nut Gr 5 NC

240 Skid Shoe Kit (10' Blades) - 8740-K

Item	Qty.	Part No.	Description
7	8	16-21218	3/4" x 2" Carriage Bolt Gr 5 NC
8	2	50-8740	2X0 Skid Shoe
9	8	57-20747	3/4" Flat Washer
10	8	70-20607	3/4" Hex Center Lock Nut Gr 2 NC

NOTE: Multiple cutting edge kits may be required.

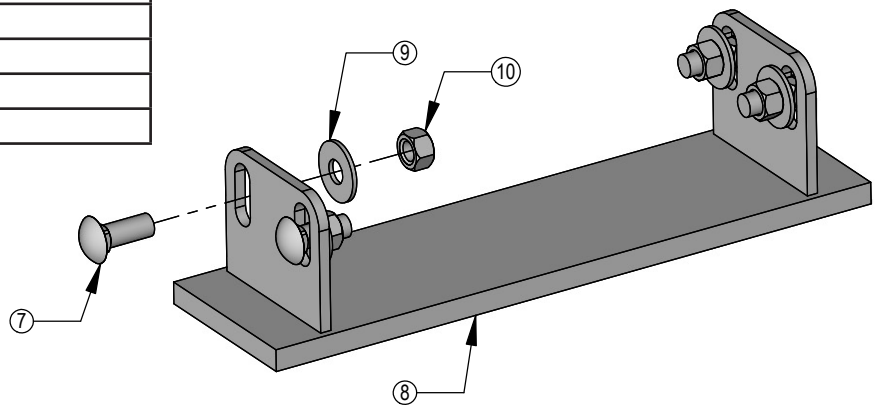
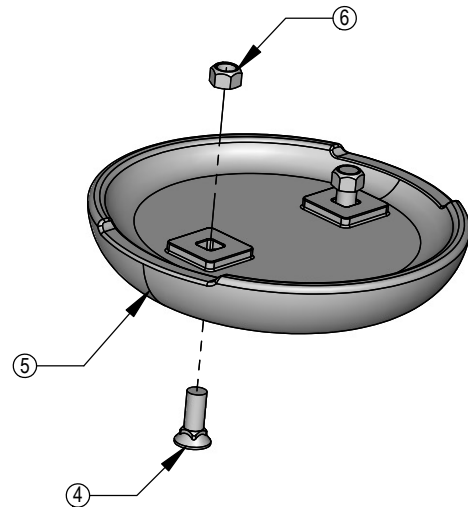
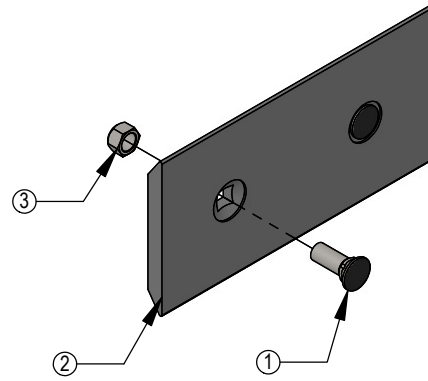

Hydraulic Schematic

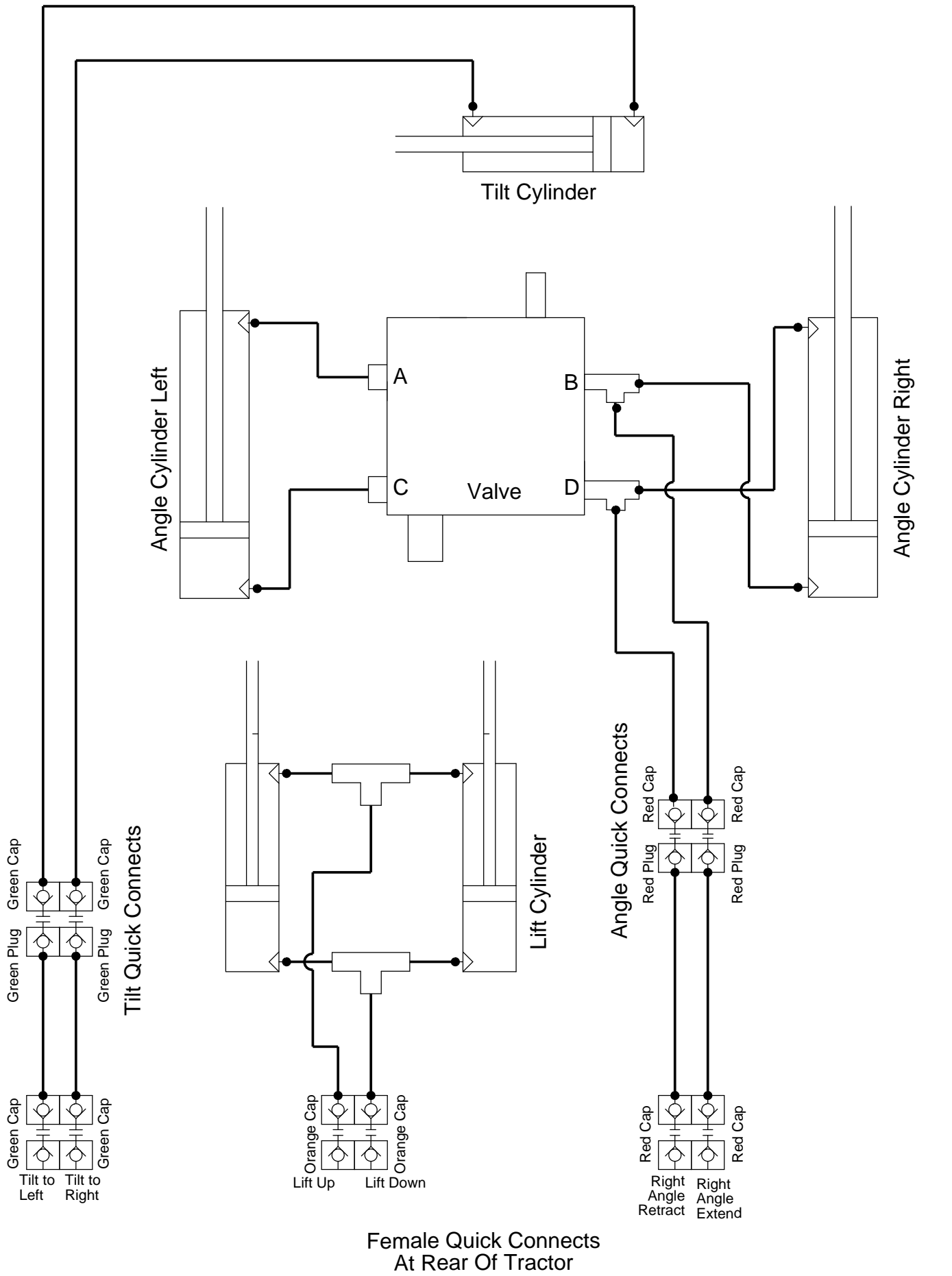

A large, empty rectangular box with a thin black border, occupying most of the page. It is intended for the user to write their notes.

A large, empty rectangular box with a thin black border, occupying most of the page. It is intended for the user to write their notes.

Contact Us

As always, if you have any questions about your Ag 240I & 241I Dozer or other products made by Grouser, feel free to contact us.

Grouser Products

755 2nd Ave NW - West Fargo, ND 58078

Phone: 1-800-747-6182

Fax: 1-701-282-8131

E-mail: grouser@grouser.com

Website: www.grouser.com

Improvements

Grouser Products Inc. is continually striving to improve its products. We reserve the right to change prices, specification, or equipment at any time without notice. We also reserve the right to make improvements or changes when it becomes practical and possible to do so without incurring any obligation to make changes or additions to the equipment sold previously.

Warranty

Grouser Products warrants to the original purchaser of each item that the product be free from defects in material and workmanship under normal use and service for a period of two years. If such equipment is found to be defective within two years, it is the obligation of Grouser Products under this warranty to repair or replace (exclusive of the cost of labor and transportation), any equipment or parts, in the judgment of Grouser Products to be defective in material or workmanship.

All equipment or parts claimed to be defective in material or workmanship must be made available for inspection at the place of business of a dealer authorized to handle the equipment covered by this warranty, or, upon request by Grouser Products, shipped to the Grouser Products factory in West Fargo, North Dakota. Grouser Products shall have no obligation to bear the cost of labor or transportation in connection with replacement or repair of any such defective parts in the setup process.

This warranty covers only defects in material and workmanship. It does not cover depreciation or damage caused by normal wear, accident, improper assembly, improper adjustments, improper maintenance including lack of proper lubrication, or improper use. Therefore, Grouser Products liability under this warranty shall not be effective or actionable unless the equipment is assembled, maintained and operated in accordance with the operating instructions accompanying the equipment. Grouser Products shall have no liability if the equipment has been altered or reworked without the written authorization of Grouser Products.

Grouser Products' parts, which are furnished under this warranty and properly installed, shall be warranted to the same extent as the original parts under this warranty if, and only if, such parts are found to be defective within the original warranty period covering the original equipment.

