



# ***Claas Xerion***

## ***Ag Pro Undercarriage***

### ***Installation Instructions***

**For Models:**

**Claas Xerion:** 4000, 4500, 5000

Purchase Date
Serial Number
Model Number
Tractor Model
Dealer

# To The Owner

This manual contains information concerning the installation of the undercarriage. You have purchased dependable, long lasting equipment, but only by proper care and operation can you expect to receive the performance and long service built into our products. Please have all operators read this manual carefully and keep the manual available for ready reference. If you have any questions or concerns, contact Grouser Products.

## Caution:

- Always use caution when working around any equipment.
- Always wear safety glasses.
- Follow tractor manufacturer's safety guidelines when installing this product.
- Use paint where necessary to prevent rust.
- Do not modify or permit anyone else to modify or alter the equipment and its components without first consulting Grouser Products.

## Note:

- When installing hardware, only finger tighten until all hardware is in place.
- A full diagram of the assembly with the full list of parts is on pages 6-7.
- Unstrap and remove any components that are attached for shipping.
- Read all instructions prior to performing installation.
- Tractor frame not shown in some diagrams for clarity.

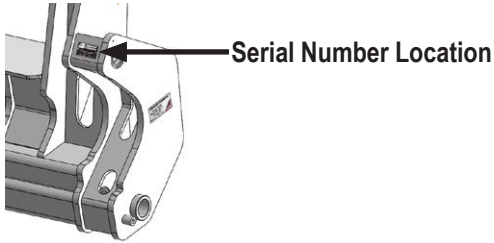

## Installation

1. If applicable, remove front weights and weight bracket from front of tractor.

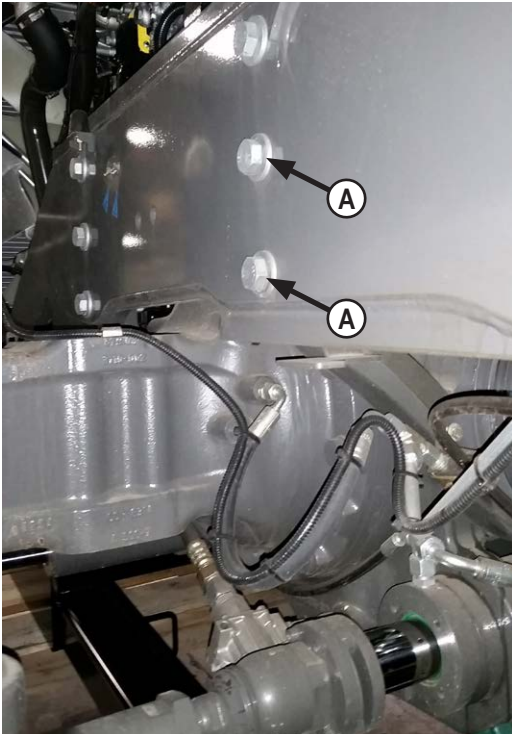

2. Behind the front axle, remove the bottom 2 bolts from each side of the tractor. You will reuse the washers in Step # 10 (A).

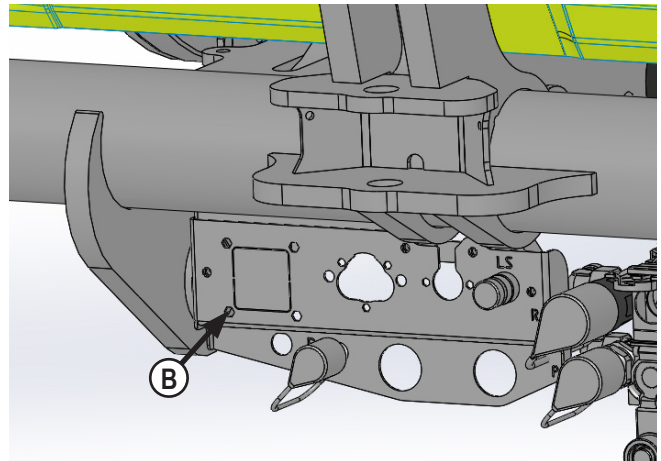

3. Remove any wire harnesses from the bracket at the front of the tractor and remove the front bracket (B). Wire harnesses will be reattached to the undercarriage.

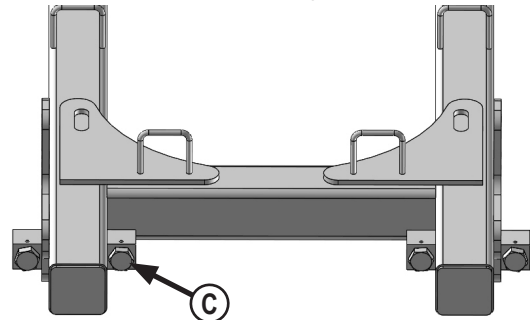

4. Install 1" x 3" bolts in the threaded boxes on the rear undercarriage (C). Turn the bolts all the way in for installation. The bolts will be adjusted in a later step.

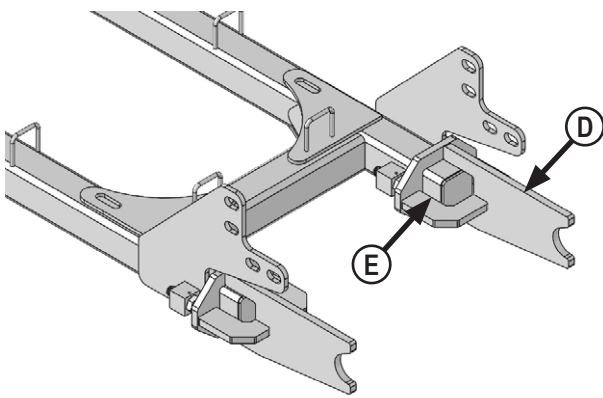

5. Install the rear brackets on the rear undercarriage. The orientation of the bracket should be as shown in the photo. The flat edge of the plate should be on the top (D) and the larger opening for the tube on the inside (E).

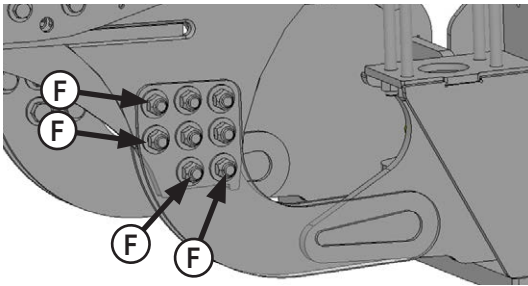

6. In front of the rear axle, remove the front 2 bolts and bottom 2 bolts on each side (F). The washers will be reused in Step #8.

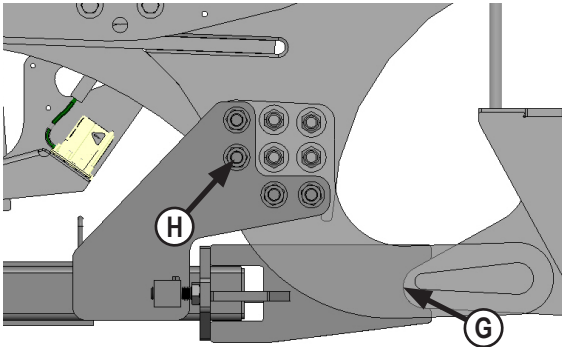

7. Position the rear undercarriage under tractor and center on the frame of the tractor.

**NOTE: When lifting the undercarriage, watch for any potential pinching of hoses or any other components to prevent any damage.**

8. Lift rear undercarriage and guide the rear brackets between the tractor frame plates that you removed the bolts from in Step #6. The round part of the bracket will fit around the round part of the tractor frame plate (G).

9. Attach the rear undercarriage to the tractor with 8 - 24mm x 100mm bolts, 16 - original tractor washers, and 8 - 24mm nuts (H).

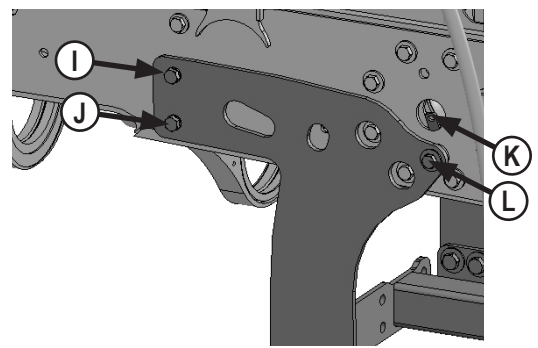

10. Attach the side plate to the tractor frame with 2 - 20mm x 130mm bolts and 2 - original tractor 20mm washers in the front top hole (I).

11. Attach the side plate to the tractor frame with 2 - 20mm x 130mm bolts, 4 - original tractor 20mm washers, and 2 - 20mm nuts in the front bottom hole (J).

12. Remove the plastic cap to gain access to the large hole above the side plate. Use the nut holder plate that was supplied to install the rear nut on each side. Hold a 3/4" flange nut in the nut plate and put the nut plate through the hole on the tractor frame (K). Use a bolt or screwdriver as a handle to hold the nut plate and lower down between the tractor frame plates. The plate can stay inside the tractor frame and plastic cap will be put on in a later step.

13. Install 2 - 3/4" x 2-3/4" bolts and 2 - 3/4" flat washers into the flange nuts that were positioned into place in Step #12 (L).

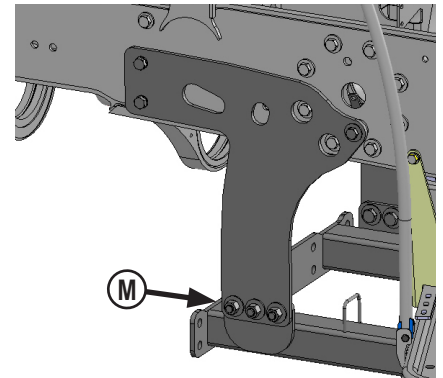

14. Attach the side plates to the rear undercarriage with 6 - 7/8" x 2-1/4" bolts, 12 - 7/8" flat washers, and 6 - 7/8" nuts (M).

15. Position undercarriage under tractor and center on the frame of the tractor. Lift undercarriage until holes of undercarriage line up with holes in the side of the tractor frame.

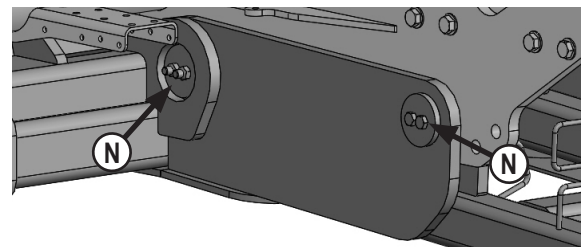

16. Attach front undercarriage to tractor frame with 4 - 5/8" x 6" bolts, 8 - Clamp Plates, 4 - Pins and 8 - 5/8" nuts (N). **Front bolts should be installed from inside and rear bolts installed from outside.**

**NOTE:** Install front 2 pins first. After front pins are installed, insert rear pin into highest bores and then jack the lower side into place to install last pin.

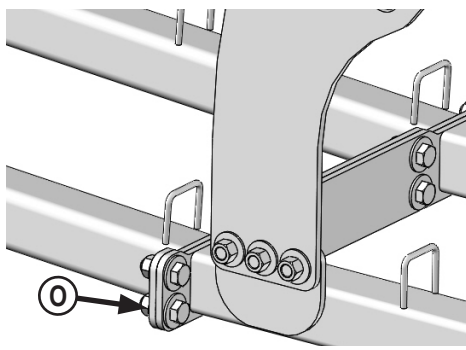

17. Attach the front undercarriage to the rear undercarriage with 8 - 7/8" x 2-1/2" bolts, 16 - 7/8" flat washers, and 8 - 7/8" nuts (**O**).
18. Torque the 20mm bolts (**I & J**) to 470 ft-lbs.
19. Torque the 5/8" bolts (**N**) to 154 ft-lbs.
20. Torque the 3/4" bolts (**L**) to 380 ft-lbs.
21. Torque the 7/8" bolts (**M & O**) to 600 ft-lbs.
22. Torque the 24mm bolts (**H**) to 909 ft-lbs.
23. Evenly unscrew the 1" bolts at the back of the undercarriage until they are tight against the rear brackets and the rear brackets are pushing against the round tractor frame plate. Torque the 1" bolts to 200 ft-lbs (**C**).
24. Install a 5/16" x 3/4" bolt into each block at the rear of the undercarriage to hold the 1" x 3" bolt in place. Torque the 5/16" bolts to 19 ft-lbs.
25. Attach any wire harnesses that were removed in Step #3 to the front of the undercarriage.
26. Put the plastic cap back in the large hole above the side plates that were removed in Step #12..

## Hose Routing

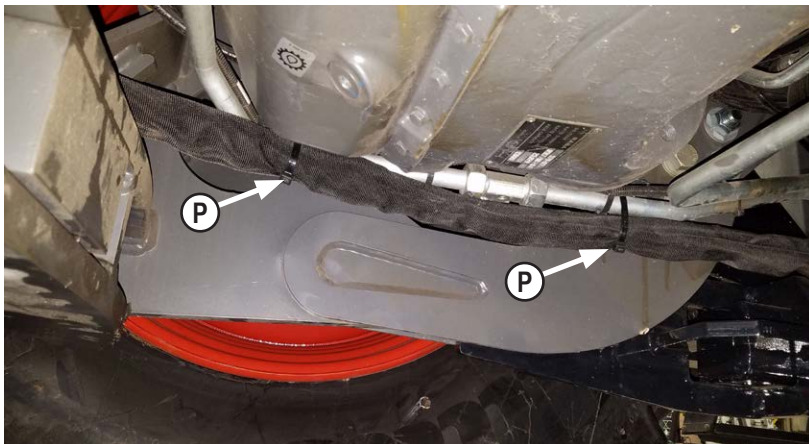

1. Route the hoses through the hose loops on the undercarriage until you reach the end of the undercarriage.
2. Continue to route the hoses to the back of the tractor. Right after the undercarriage ends, use zip ties to secure the hoses to the large steel line on each side on the tractor (**P**).
3. Continue to route hoses to the back of the tractor. Exit the tractor frame and plug the hoses into the rear SCV's.
4. Use zip ties to attach hoses, where necessary, to avoid rubbing and pinch areas.

# Assembling Lift Components

---

---

1. Refer to the Blade Owner's Manual & Parts Book for instructions on how to assemble the lift components.

## Maintenance

---

---

1. After first 8 hours of use, re-torque all bolts.
2. Check all fasteners regularly to ensure proper operation of equipment.
3. Inspect all equipment for existing or potential damages every 10 hours or less.

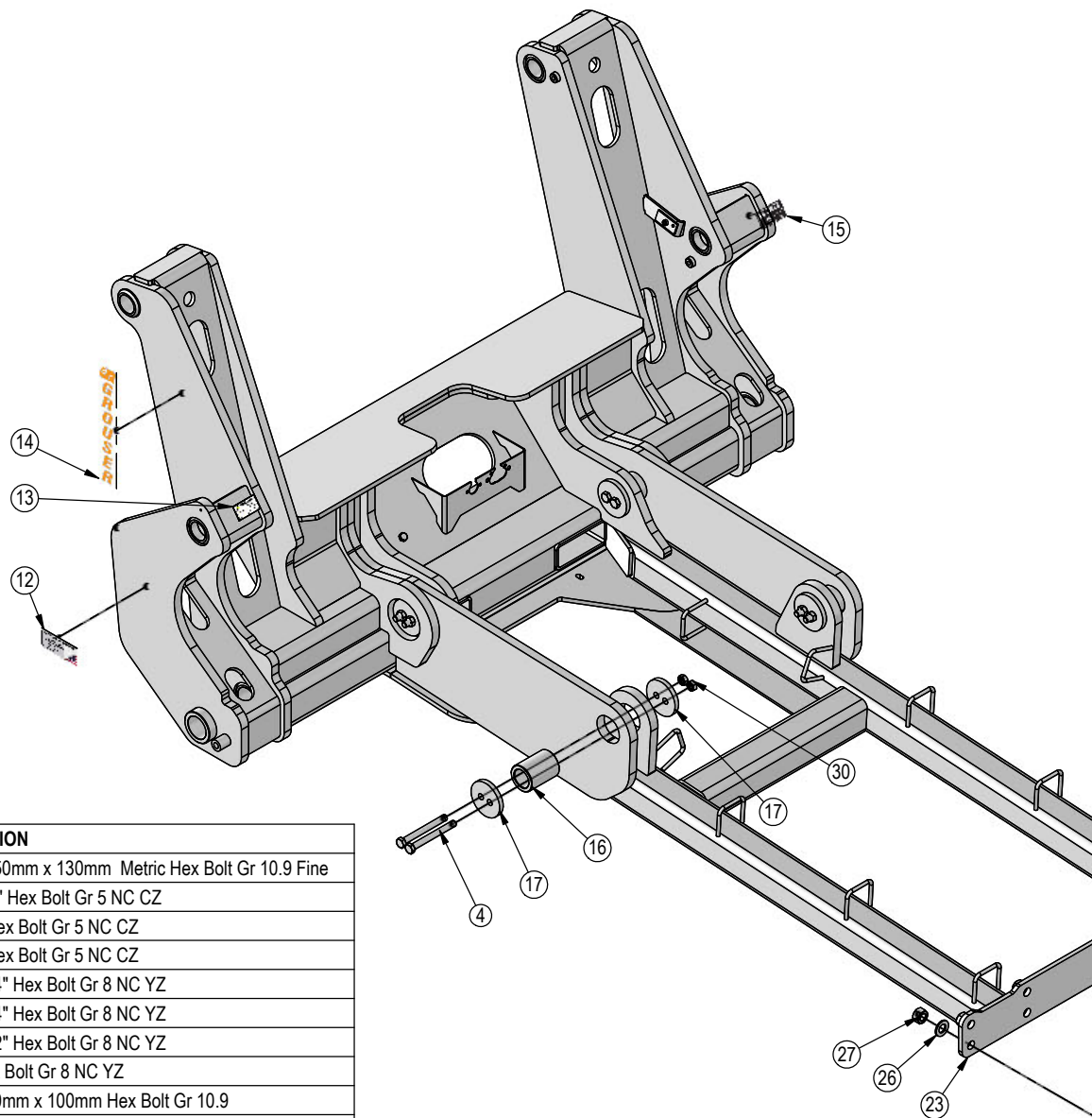

ITEM NO.	QTY.	PART NO.	DESCRIPTION
1	4	16-20150130	20mm x 1.50mm x 130mm Metric Hex Bolt Gr 10.9 Fine
2	4	16-20032	5/16" X 3/4" Hex Bolt Gr 5 NC CZ
3	4	16-20124	1/2" X 1" Hex Bolt Gr 5 NC CZ
4	8	16-20200	5/8" X 6" Hex Bolt Gr 5 NC CZ
5	2	16-20511	3/4" X 2-3/4" Hex Bolt Gr 8 NC YZ
6	6	16-20539	7/8" X 2-1/4" Hex Bolt Gr 8 NC YZ
7	8	16-20540	7/8" X 2-1/2" Hex Bolt Gr 8 NC YZ
8	4	16-20562	1" X 3" Hex Bolt Gr 8 NC YZ
9	8	16-2486	24mm x 3.0mm x 100mm Hex Bolt Gr 10.9
10	1	18-17996-L	Xerion Rear Bracket
11	1	18-17996-R	Xerion Rear Bracket
12	2	27-18887	Grouser Name Plate Decal
13	1	27-40962	Warning Prop 65 Decal
14	2	27-9505	Grouser Vertical Decal
15	1	NA	Grouser Dozer Metal Serial Tag
16	4	43-18531	Pin
17	8	44-18003	Plate, Clamp
18	1	44-41725-L R1	Side Plate
19	1	44-41725-R R1	Side Plate
20	1	44-41931	Plate, Cover
21	2	44-41934	Plate, Nut Holder
22	1	54-41720	Xerion UC Weld, Rear
23	1	54-41890	Xerion UC Weld, Front
24	8	57-20744	1/2" Flat Washer CZ
25	2	57-20747	3/4" Flat Washer CZ
26	28	57-20818	7/8" Flat Washer Heavy Duty Gr 8 (USS) YZ
27	14	70-20598	7/8" Hex Nut Gr 8 NC CZ
28	4	70-20604	1/2" Hex Center Lock Nut Gr 5 NC CZ
29	2	70-40998	3/4" Flange Hex Nut Gr 5 NC YZ
30	8	70-20646	5/8" Hex Top Lock Nut Gr 5 NC CZ
31	2	70-20850-10	M20-1.5 Class 10.9 Hex Nut CZ
32	8	70-20874	M24-3.0 Class 8.8 Hex Nut CZ
33	16		24mm Flat Washer - Use original tractor washer
34	6		20mm Flat Washer - Use original tractor washer

Front of Undercarriage

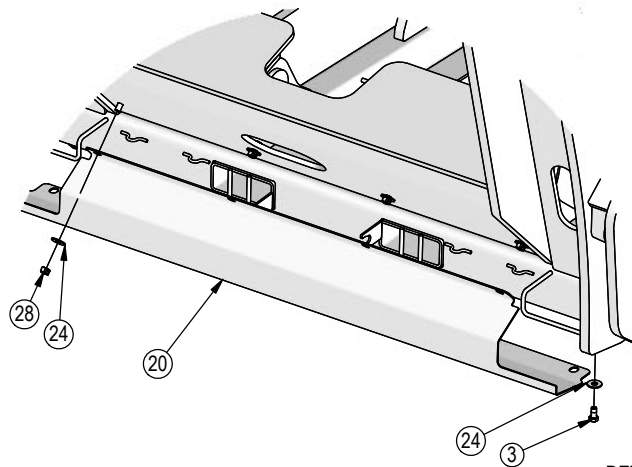

DETAIL A  
SCALE 1 : 18

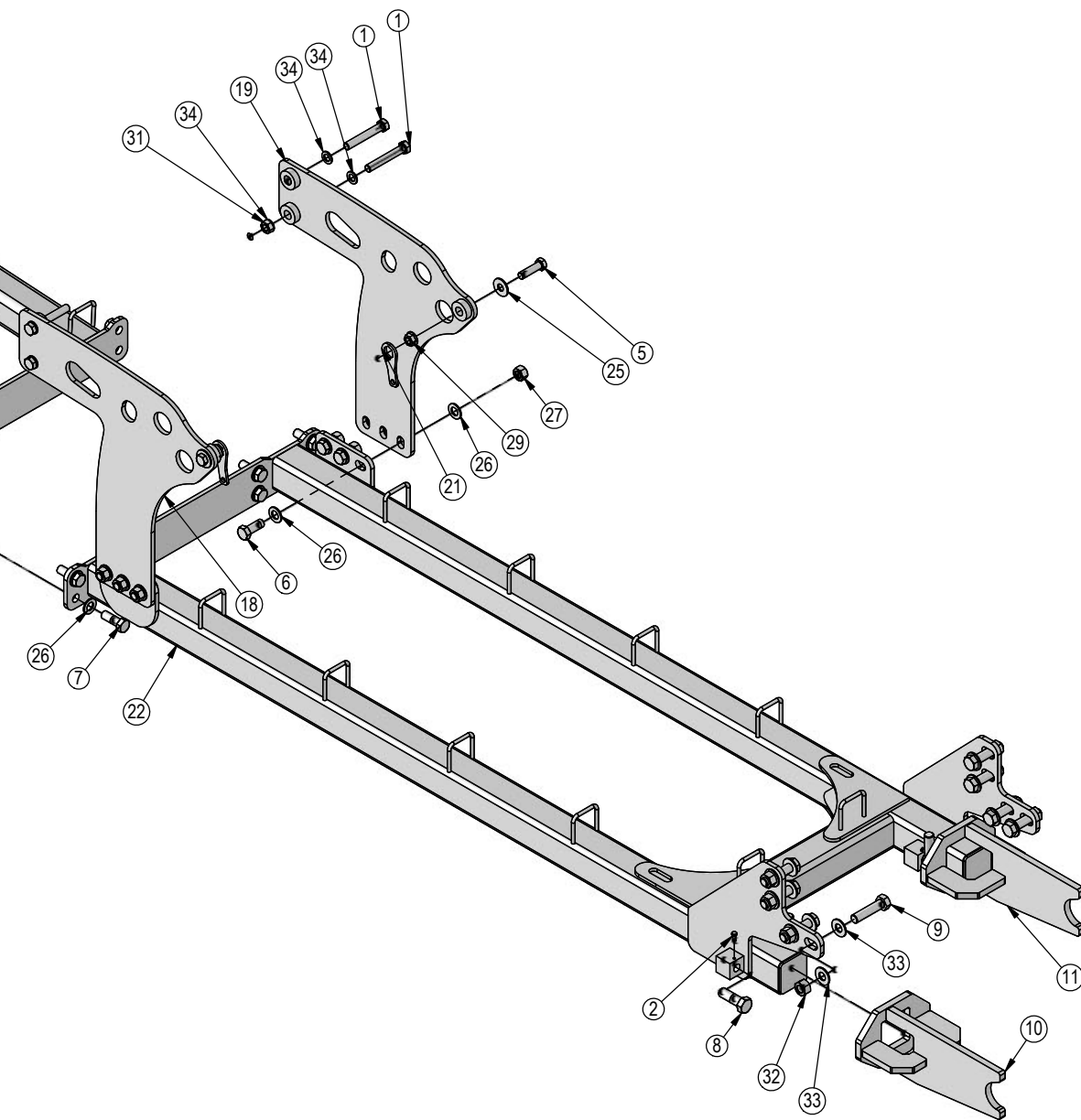

DWG. NO.: 41890-A

# Improvements

---

---

Grouser Products Inc. is continually striving to improve its products. We reserve the right to change prices, specification, or equipment at any time without notice. We also reserve the right to make improvements or changes when it becomes practical and possible to do so without incurring any obligation to make changes or additions to the equipment sold previously.

## Warranty

---

---

Grouser Products warrants to the original purchaser of each item that the product be free from defects in material and workmanship under normal use and service for a period of **two (2) years for Agriculture Series Blades and one (1) year for Heavy Duty Series from date of original retail delivery.**

### The obligation of the consumer under this warranty:

1. To read the operators manual and to operate, lubricate, maintain and store equipment in accordance with the instructions listed in the operators manual.
2. To inspect equipment and if any part needs repair or replacement when continued use would cause damage or wear to other parts or safety.
3. All equipment or parts claimed to be defective in material or workmanship must be made available for inspection at the place of business of a dealer authorized to handle the equipment covered by this warranty, or, upon request by Grouser Products, shipped to the Grouser Products factory in West Fargo, North Dakota.

### The obligation of the dealer under this warranty:

1. Complete warranty registration form and submit within 30 days of sale.
2. Contact Grouser Products for authorization prior to performing any warranty repairs or part replacement.
3. Complete warranty request form and submit with photos and supporting documentation.

### The obligation of Grouser Products under this warranty:

1. Repair or replace, any equipment or parts, in the judgment of Grouser Products to be defective in material or workmanship.
2. Grouser Products will cover the cost of parts and ground shipping at dealer invoice only.
3. Grouser Products shall have no obligation to bear the cost of labor or transportation in connection with replacement or repair of any such defective parts.

### This warranty does not cover:

1. Depreciation or damage caused by normal wear, accident, improper assembly, improper adjustments.
2. Improper maintenance including lack of proper lubrication, or improper use. Including loose bolts, nuts, or fitting due to over tightening or vibration after 20 hours of operation.
3. Repairs or alterations without authorization from a Grouser Products representative.
4. Grouser Products shall have no liability if the equipment has been altered or reworked without the written authorization of Grouser Products.

Grouser Products' parts, which are furnished under this warranty and properly installed, shall be warranted to the same extent as the original parts under this warranty if, and only if, such parts are found to be defective within the original warranty period covering the original equipment.

**NO EMPLOYEE OR REPRESENTATIVE OF GROUSER PRODUCTS IS AUTHORIZED TO CHANGE THE WARRANTY IN ANY WAY OR GRANT ANY OTHER WARRANTY.**

## Contact Us

---

---

As always, if you have any questions about your system or other products made by Grouser, feel free to contact us.



755 2nd Ave NW - West Fargo, ND 58078  
+1 701-282-7710 | info@grouser.com  
www.grouser.com