

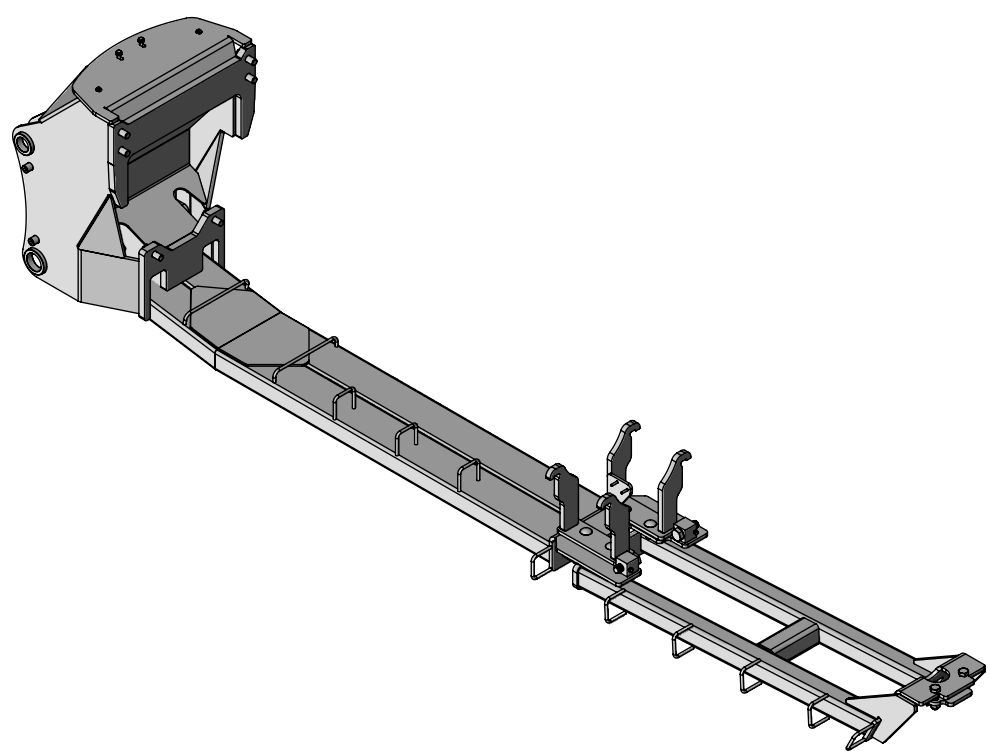

Case Optum & New Holland T7 HD Undercarriage Installation Instructions



For Models:
Case Optum: 270, 300
New Holland T7 HD: 290, 315

Purchase Date
Serial Number
Model Number
Tractor Model
Dealer

To The Owner

This manual contains information concerning the installation of the undercarriage. You have purchased dependable, long lasting equipment, but only by proper care and operation can you expect to receive the performance and long service built into our products. Please have all operators read this manual carefully and keep the manual available for ready reference. If you have any questions or concerns, contact Grouser Products.

Caution:

- Always use caution when working around any equipment.
- Always wear safety glasses.
- Follow tractor manufacturer's safety guidelines when installing this product.
- Use paint where necessary to prevent rust.
- Do not modify or permit anyone else to modify or alter the equipment and its components without first consulting Grouser Products.

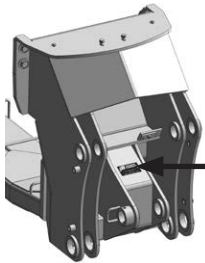

Serial Number Location

Note:

- When installing hardware, only finger tighten until all hardware is in place.
- A full diagram of the assembly with the full list of parts is on pages 6-7.
- Unstrap and remove any components that are attached for shipping.
- Read all instructions prior to performing installation.
- Tractor frame not shown in some diagrams for clarity.



To ensure the safety of those working under and around the machine, apply parking brake, remove key from ignition, and block tires before working on the machine.

Pre-Installation



1. Disconnect speed sensor wire harness.
2. Remove speed sensor and bracket from fuel tank frame (A). The speed sensor will be reinstalled in Step #4. Keep original bracket in case undercarriage is ever removed.



3. Install the left and right brackets on fuel tank frame (B). The top hook on the brackets will rest on the fuel tank frame. Only left side is shown in picture

NOTE: Refer to diagram on pages 6-7 for correct orientation of brackets. The speed sensor will be reinstalled on the right bracket.

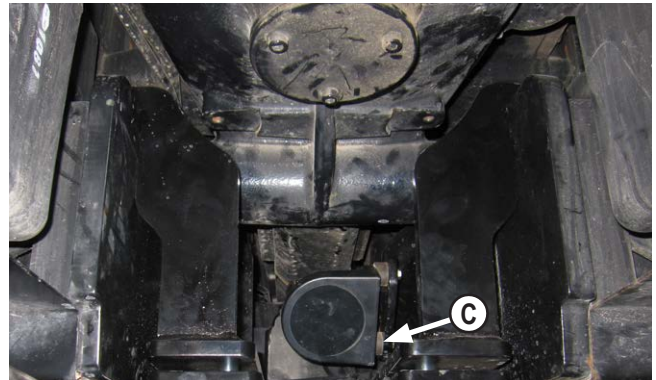

4. Install speed sensor (C) along with original spacers on right bracket with 3 - 1/4" x 1-1/2" bolts and 3 - 1/4" washers.



5. Remove hood latch (D), cover plate (E), front weights and weight carrier (F) from tractor.



Caution: When removing weight carrier, be careful to not damage the suspension hydraulics inside weight carrier cavity.

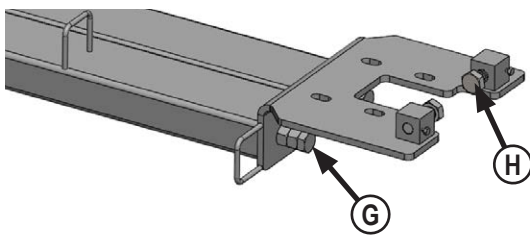

6. Install 2 - 1" x 6" bolts and 2 - 1" nuts at rear of undercarriage (G). Turn bolts all the way in for installation. The bolts will be adjusted in Step #19.

7. Install 2 - 1" x 3" bolts from the inside into threaded boxes at rear of undercarriage (H). Turn bolts in until the bolt end is flush with face of block. The bolts will be adjusted in Step #17.

Installation

8. Center undercarriage under tractor.



Caution: When lifting undercarriage, watch for any potential pinching of hoses or any other components to prevent any damage.

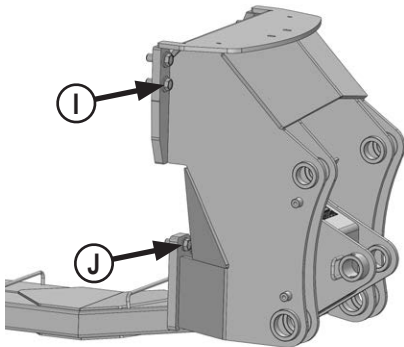

9. Lift the undercarriage and attach front of undercarriage to tractor with 4 - 22mm x 60mm bolts and 4 - 7/8" hardened flat washers in top 4 holes (I) and 2 - 20mm x 60mm and 2 - 3/4" hardened flat washers in bottom 2 holes (J).

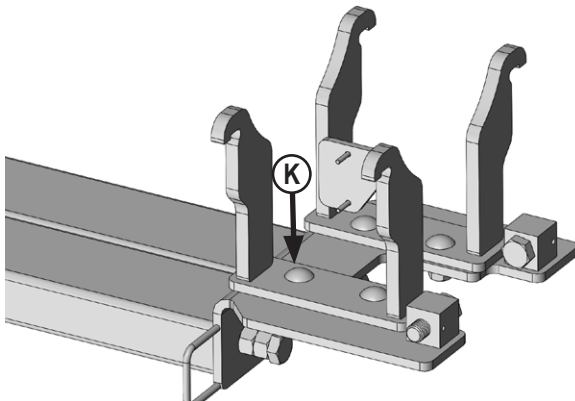

10. Lift rear of undercarriage and attach to the left and right brackets with 4 - 3/4" x 2" carriage bolts, 4 - 3/4" flat washers, and 4 - 3/4" nuts (K).

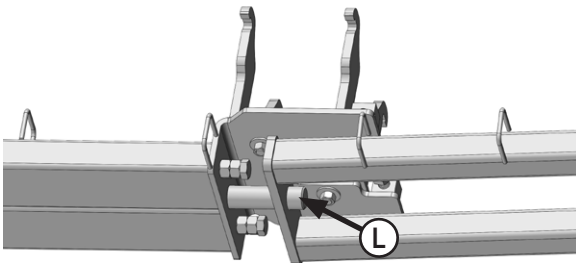

11. Center push pole under rear of tractor. Lift and slide the front end of the push pole onto the round pin at rear of undercarriage (L).

NOTE: View is from underneath the undercarriage.

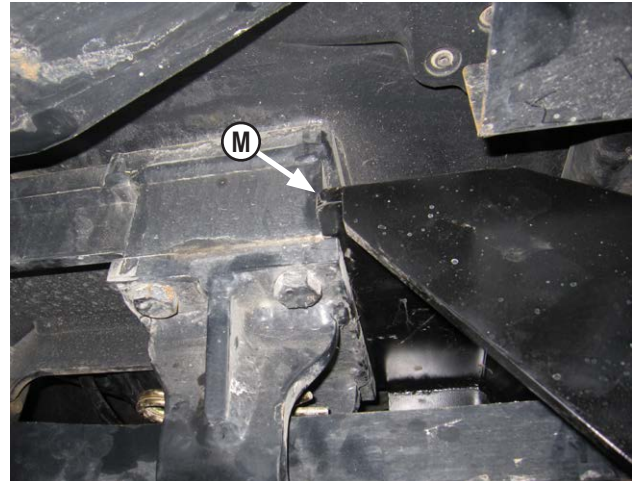

NOTE: The drawbar may need to be pulled out to allow room for the push pole to be lifted into place.

12. Lift rear of push pole and set on top of drawbar bracket (M).

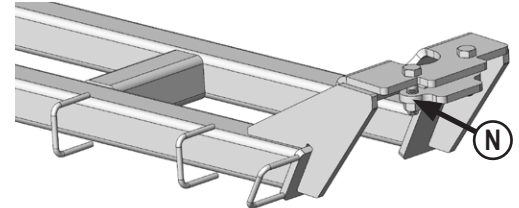

13. Attach clamp plate to rear of push pole with 2 - 3/4" nuts (N).

14. Torque front 22mm bolts (I) to 680 ft-lbs.

15. Torque front 20mm bolts (J) to 432 ft-lbs.

16. Verify that the brackets from Step #3 are still in position. Torque 3/4" carriage bolts (K) to 257 ft-lbs.

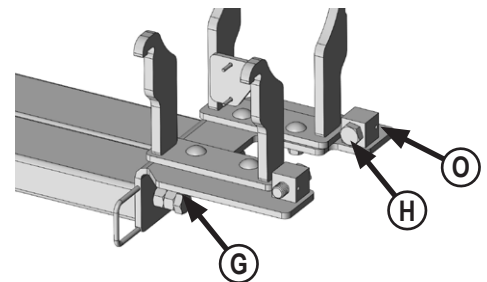

17. Evenly screw in 1" bolts in threaded boxes at rear of undercarriage until they are tight against fuel tank frame (H). Torque 1" bolts to 8-10 ft-lbs.

18. Install 2 - 5/16" x 3/4" bolts into blocks at rear of undercarriage to lock 1" bolts (O). Torque 5/16" bolts to 19 ft-lbs.

19. Evenly unscrew 1" bolts at rear of undercarriage until they are tight against push pole (G). Torque 1" bolts to 90-95 ft-lbs.

20. Tighten nuts tight against rear of undercarriage. Use nuts to lock bolts in place.

21. Torque rear clamp plate 3/4" nuts (N) to 257 ft-lbs.

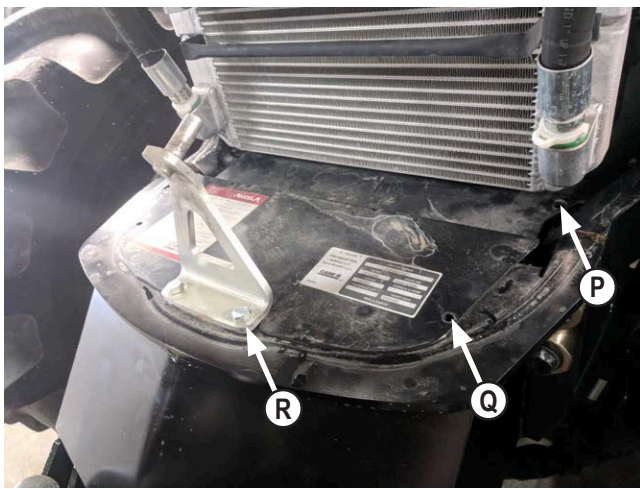

22. Attach cover plate with original 2 bolts and washers in rear holes under the radiator (**P**).
23. Attach cover plate to top of undercarriage with 2 - 6mm x 30mm bolts, 4 - 6mm washers, and 2 - 6mm nuts (**Q**).
24. Attach hood latch to top of undercarriage with 2 - 10mm x 40mm bolts, 4 - 10mm washers, and 2 - 10mm nuts (**R**). Keep hardware loose.
25. Close tractor hood and verify hood closes tightly. If necessary, adjust position of hood latch by moving it forward or back. Torque the 10mm bolts to 59 ft-lbs.

Hose Routing

1. Route hoses through the hose loops on the undercarriage and push pole.



2. Route hoses up through opening between left side rear 3-point lower arm and drawbar support (**S**).
3. Plug hoses into open SCV's at rear of tractor.
4. Use zip ties to group hoses together and secure to top hole of the bracket (**T**).

NOTE: The installer is responsible to route hoses in a practical manner, to protect hoses around sharp corners and moving objects, and secure hoses.

Assembling Lift Components

1. Refer to the Blade Owner's Manual & Parts Book for instructions on how to assemble the lift components.

Maintenance

1. After first 8 hours of use, re-torque all bolts.
2. Check all fasteners regularly to ensure proper operation of equipment.
3. Inspect all equipment for existing or potential damages every 10 hours or less.

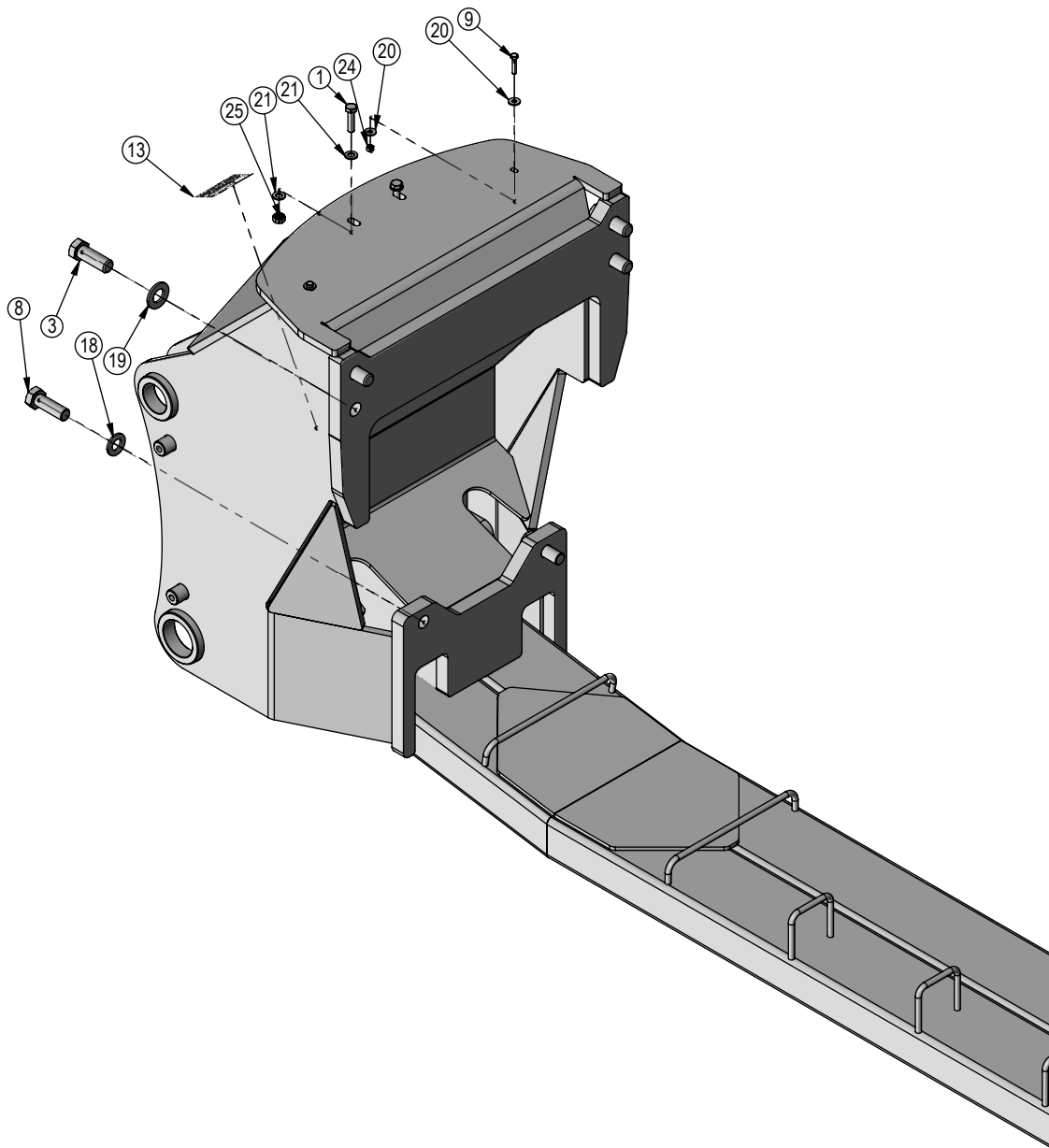

ITEM NO.	QTY.	PART NO.	DESCRIPTION
1	2	16-1015040	10mm x 1.50mm x 40mm Metric Hex Bolt Gr 10.9
2	2	16-17271	1" X 6" Hex Bolt Gr 8 NC (Full Thread)
3	4	16-2215060	22mm x 1.5mm x 60mm Gr. 10.9 Hex Bolt
4	3	16-20006	1/4" X 1-1/2" Hex Bolt Gr 5 NC
5	2	16-20032	5/16" x 3/4" Hex Bolt Gr 5 NC
6	2	16-20562	1" x 3" Hex Bolt Gr 8 NC
7	4	16-21218	3/4" x 2.00" Carriage Bolt Gr.5
8	2	16-2487	20mm x 2.5mm x 60mm Hex Bolt Gr. 10.9
9	2	16-610030	6mm x 1.00mm x 30mm Metric Hex Bolt Gr 10.9
10	1	17-41835	Case Optum Push Pole
11	1	18-40730	Bracket, Left
12	1	18-40731	Bracket, Right
13	1	NA	Grouser Dozer Metal Serial Tag
14	1	44-41832	Plate, Clamp
15	1	54-40700	Case Optum UC Weld
16	3	57-20740	1/4" Flat Washer
17	4	57-20747	3/4" Flat Washer
18	2	57-20757	3/4" Flat Washer - 1-1/2" OD
19	4	57-20758	7/8" SAE Hardened Flat Washer - 1-3/4" OD
20	4	57-20820	6mm Flat Washer
21	4	57-20822	10mm Flat Washer
22	2	70-20599	1" Hex Nut Gr 8 NC
23	6	70-20607	3/4" Center Lock Hex Nut Gr 2 NC
24	2	70-20864	6mm Hex Nut 1.0 Pitch
25	2	70-20867	10mm Hex Nut 1.5 Pitch

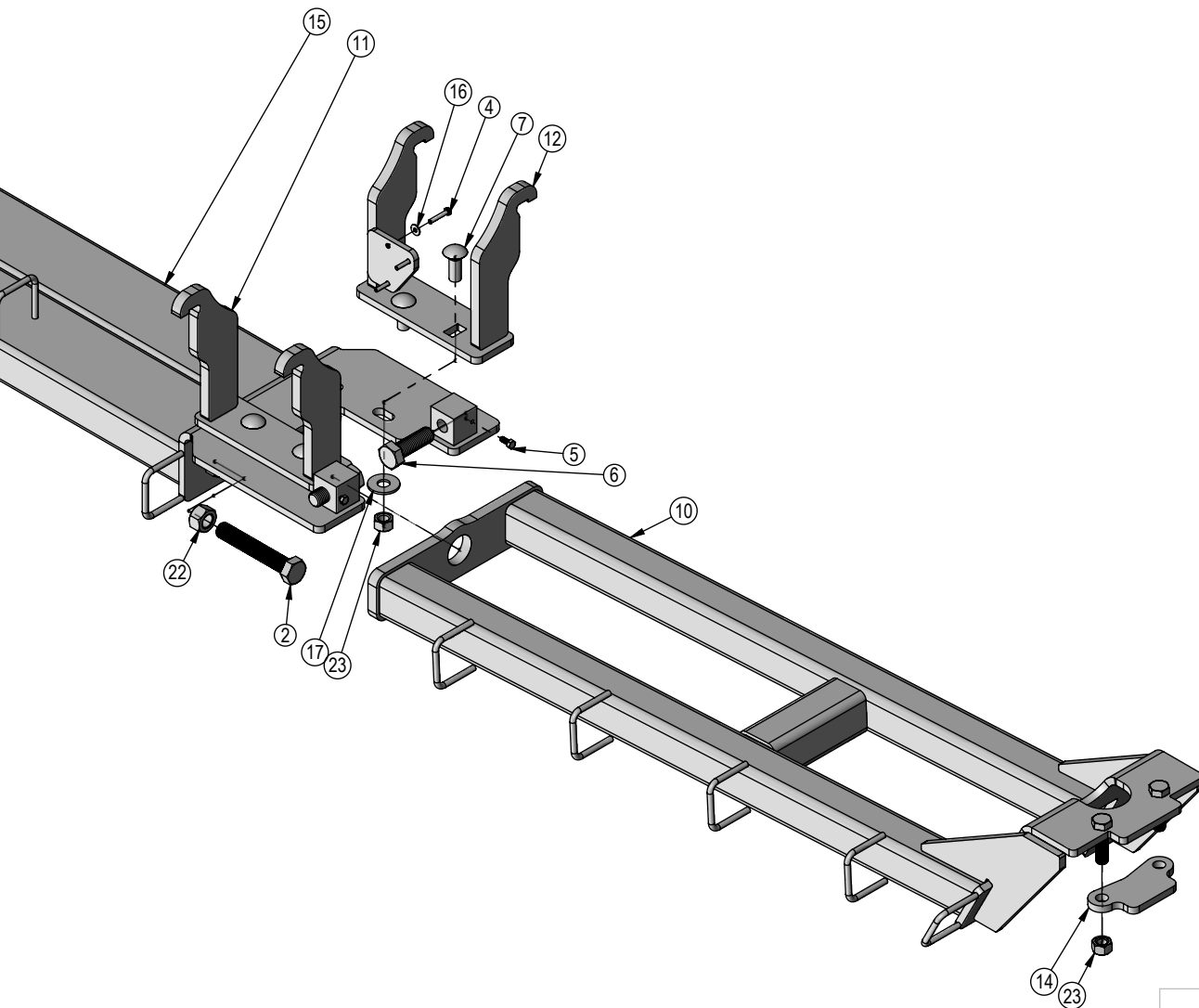

DWG. NO.: 40700-A

Improvements

Grouser Products Inc. is continually striving to improve its products. We reserve the right to change prices, specification, or equipment at any time without notice. We also reserve the right to make improvements or changes when it becomes practical and possible to do so without incurring any obligation to make changes or additions to the equipment sold previously.

Warranty

Grouser Products warrants to the original purchaser of each item that the product be free from defects in material and workmanship under normal use and service for a period of **two (2) years for Agriculture Series Blades and one (1) year for Heavy Duty Series from date of original retail delivery.**

The obligation of the consumer under this warranty:

1. To read the operators manual and to operate, lubricate, maintain and store equipment in accordance with the instructions listed in the operators manual.
2. To inspect equipment and if any part needs repair or replacement when continued use would cause damage or wear to other parts or safety.
3. All equipment or parts claimed to be defective in material or workmanship must be made available for inspection at the place of business of a dealer authorized to handle the equipment covered by this warranty, or, upon request by Grouser Products, shipped to the Grouser Products factory in West Fargo, North Dakota.

The obligation of the dealer under this warranty:

1. Complete warranty registration form and submit within 30 days of sale.
2. Contact Grouser Products for authorization prior to performing any warranty repairs or part replacement.
3. Complete warranty request form and submit with photos and supporting documentation.

The obligation of Grouser Products under this warranty:

1. Repair or replace, any equipment or parts, in the judgment of Grouser Products to be defective in material or workmanship.
2. Grouser Products will cover the cost of parts and ground shipping at dealer invoice only.
3. Grouser Products shall have no obligation to bear the cost of labor or transportation in connection with replacement or repair of any such defective parts.

This warranty does not cover:

1. Depreciation or damage caused by normal wear, accident, improper assembly, improper adjustments.
2. Improper maintenance including lack of proper lubrication, or improper use. Including loose bolts, nuts, or fitting due to over tightening or vibration after 20 hours of operation.
3. Repairs or alterations without authorization from a Grouser Products representative.
4. Grouser Products shall have no liability if the equipment has been altered or reworked without the written authorization of Grouser Products.

Grouser Products' parts, which are furnished under this warranty and properly installed, shall be warranted to the same extent as the original parts under this warranty if, and only if, such parts are found to be defective within the original warranty period covering the original equipment.

NO EMPLOYEE OR REPRESENTATIVE OF GROUSER PRODUCTS IS AUTHORIZED TO CHANGE THE WARRANTY IN ANY WAY OR GRANT ANY OTHER WARRANTY.

Contact Us

As always, if you have any questions about your system or other products made by Grouser, feel free to contact us.



755 2nd Ave NW - West Fargo, ND 58078
+1 701-282-7710 | info@grouser.com
www.grouser.com