



Ag Pro Plus HD

Owner's Manual & Parts Book

Grouser Products

755 2nd Ave NW - West Fargo, ND 58078

Phone: 1-800-747-6182

Fax: 1-701-282-8131

E-mail: grouser@grouser.com

Website: www.grouser.com

Purchase Date
Serial Number
Model Number
Tractor Model
Dealer

Description	Page
Welcome To The Owner & Torque Specifications	2
Safety Precautions & Pre-Installation	3
Maintenance & Lubrication	3
Lift System	4-5
Tractor Side Hydraulics	5-7
Initial Startup	8
Hydraulic Angle System Operation & Relief Valve Adjustment	9
Connecting and Disconnecting	10
Skid Shoe Adjustment & Tilt Plate Adjustment	11
Ag Pro Plus HD Blade	12-13
Hydraulic Angle - Hydraulic Tilt System	14-15
Hydraulic Angle - Hydraulic Tilt Electric Hydraulics	16-17
Hydraulic Mulit-Coupler Maintenance	18-19
Notes	20
Hydraulic Schematics	21
Notes	22-23
Contact Us, Improvements, & Warranty	24

Thank you for your recent purchase of a Grouser Ag Pro Plus HD Dozer. Welcome to the family of satisfied Grouser blade owners. Grouser Products is committed to offering quality products to help professionals in their daily jobs. We are also committed to providing you the highest level of customer satisfaction possible. Again, thank you for your patronage. We look forward to serving you.

This manual contains information concerning the operation, adjustment, safety and maintenance of the Ag Pro 660HD Dozer. You have purchased a dependable, long lasting piece of equipment. You can expect to receive long lasting performance and long service built into our products with proper care and operation. Please have all operators read and understand this manual carefully. Keep the manual available for reference. If, for any reason, you have questions or comments, we would be happy to hear from you. Call our toll-free number, 800-747-6182, or send us an e-mail at info@grouser.com. You can expect us to respond to your e-mail in a timely manner.

Tighten all bolts to the values listed below unless otherwise noted. Refer to the parts lists for proper length and grade of the bolts.

Size	Torque - Dry (ft-lbs)			
	SAE Grade 5		SAE Grade 8	
	UNC	UNF	UNC	UNF
5/16	17	19	24	27
3/8	30	35	45	50
7/16	50	55	70	80
1/2	75	85	110	120
9/16	110	120	150	170
5/8	150	170	210	240
3/4	260	300	380	420
7/8	430	470	600	670
1	640	720	910	1020

Size	Torque - Dry (ft-lbs)
	Grade 10.9
M18 x 2.50	284
M20 x 2.50	401
M22 x 2.50	547
M24 x 3.00	694

A careful operator is the best operator. Most accidents can be avoided by observing certain precautions. To help prevent accidents, read and take the following precautions before operating this equipment. In addition, please follow all safety and operational instructions of your tractor manufacturer.

The Ag Pro Plus HD Dozer:

1. The Ag Pro Plus HD Dozer should be operated only by those who are responsible and instructed to do so.
2. Read the owner's manual carefully before using this equipment. Lack of operating knowledge can lead to accidents.
3. Keep the Ag Pro Plus HD Dozer maintained in reliable and satisfactory condition to ensure your safety.
4. Make sure the area is clear of people before moving any equipment.
5. Do not modify or permit anyone else to modify or alter the equipment and its components without first consulting Grouser Products.
6. Lower the blade to the ground when not in use.

Servicing the Ag Pro Plus HD Dozer:

1. Read and follow all safety instructions provided by the tractor manufacturer.
2. Always use proper personal safety gear when performing maintenance on equipment.
3. Before servicing, relieve hydraulic pressure, stop engine and fully engage parking brake.
4. Escaping hydraulic fluid under pressure can penetrate skin causing serious injury. If fluid is injected into skin, obtain medical attention immediately.
 - DO NOT use your hand to check for leaks. Use a piece of cardboard or paper to search for leaks.
 - Stop the engine and relieve pressure before connecting or disconnecting lines.
 - Tighten all connections before starting the engine or pressurizing lines.

Storing the Ag Pro Plus HD:

1. Thoroughly clean the Ag Pro Plus HD Dozer before storage. Use paint where necessary to prevent rust.
2. Check the Ag Pro Plus HD Dozer for worn or damaged parts. Install new parts as required.
3. Lubricate all pins and joints.

Unstrap and remove the lift frame, hoses, top arms, and any boxes of hardware from the undercarriage. If any components are missing, call Grouser.

Install undercarriage per the tractor specific mounting instructions.

Due to the harsh environment this equipment operates in, the following tasks should be performed every 10 hours or less.

- Inspect all equipment before operation for existing or potential damage.
- Lubricate all joints with high quality grease. See below for grease locations.
- Inspect all bolts, and tighten any loose bolts to torque specifications on page 2.
- Check replaceable cutting edge for wear ensuring there is enough material to prevent permanent damage to the Ag Pro 660HD Dozer. For cutting edge information, see pages 13 .
- Check hydraulic cylinders and hoses for damage or leaks. For replacement parts, see hydraulic pages 4, 6-7 and 16-17.
- Make sure all non-rotating pins are secured properly.
- Inspect all decals and order replacement decals from your dealer if any are damaged or worn.
- For multi-coupler maintenance, see pages 18-19.
- Inspect all tilt-ways for wear. See page 11 for tilt plate adjustment.
- Replace parts with original parts only.

ITEM NO.	QTY.	PART NO.	DESCRIPTION
1	1	11-40760-L	Ag Pro Plus Manual Pitch Top Arm Assy
2	1	11-40760-R	Ag Pro Plus Manual Pitch Top Arm Assy
3	2	16-20002	1/4" x 3/4 " Hex Bolt Gr 5 NC
4	2	16-20214	3/4" x 1" Hex Bolt Gr 5 NC
5	2	16-20216	3/4" x 1-1/2" Hex Bolt Gr 5 NC
6	4	16-20217	3/4" x 1-3/4" Hex Bolt Gr 5 NC
7	4	16-20220	3/4" x 2-1/2" Hex Bolt Gr 5 NC
8	10	16-20566	1" X 4" Hex Bolt Gr 8 NC
9	8	19-13515	Spacer, NR Pin
10	2	19-13525	2.75 x 2.50 x 4.75 Spring Bushing
11	8	19-16695	2.25 x 2.00 x 1.50 Spring Bushing
12	2	19-18089	2.75 x 2.50 x 3.75 Spring Bushing
13	2	26-34751	5 x 18 Hydraulic Cylinder
14	2	27-9503	Pinch Decal (Foot)
15	1	32-19120	HD Lift Frame
16	1	34-14961	Manual Canister Small

ITEM NO.	QTY.	PART NO.	DESCRIPTION
17	2	43-14725	Lift Frame / UC Pin
18	4	43-18120	Top Pin Weld
19	2	43-18127	Top Arm Pin Weld
20	2	43-18175	Lift Cyl Pin Weld
21	2	43-18635	Ag Pro Plus QA Pin
22	1	45-18110-L	Male Quick Attach, Ag Pro S
23	1	45-18110-R	Male Quick Attach, Ag Pro S
24	2	57-1530	3" OD X .75 ID X .25" HD Flat Washer
25	6	57-1811	2" Washer
26	2	57-20740	1/4" Flat Washer
27	10	57-20747	3/4" Flat Washer
28	12	58-9369	Straight 1/8" NPT Grease Zerk
29	10	70-20599	1" Hex Nut Gr 8 NC
30	2	70-20607	3/4" Center Lock Hex Nut Gr 2 NC
31	2	70-20610	1/4" Nyloc Hex Nut Gr 5 NC

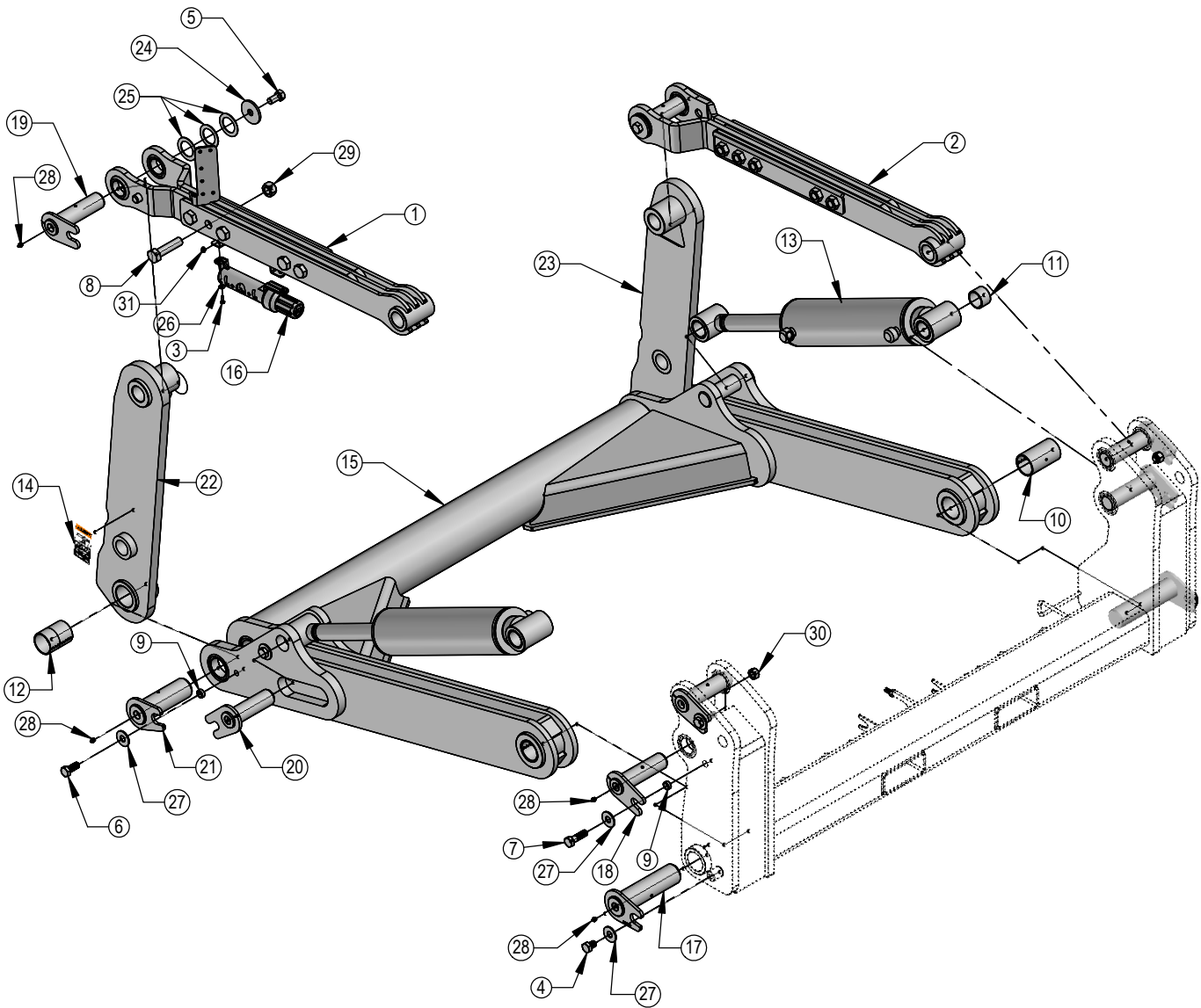

Note: When ordering a cylinder seal kits, the part number on the cylinder is needed. The number is stamped on the base end of the cylinder opposite of the hydraulic ports.

No. On Cylinder	Part No.	Description
26-34751	49-12275	Monarch Seal Kit 5" (658457) Nitrided Rod

DWG. NO.: 42440

Some assembly of Lift System components is necessary. Follow the steps listed below. See diagram below for the correct hardware and orientation of parts.

1. Remove all pins and fasteners on each side of the undercarriage and set aside for later installation.
2. Position the lift frame between the two plates on both sides of the undercarriage and align to the bottom holes.
3. Insert pins and hardware to attach the lift frame, the base end of the lift cylinders, and the top arms to the undercarriage.
4. Insert pins and hardware to attach the male quick attaches to the lift frame, and to the top arms.
5. Torque all fasteners according to the specifications on Page 2.

Note: Refer to Pages 6-7 for the correct hose lengths and hose location.

Note: All connections are identified by spiral bands. 2 bands are from the base end of a cylinder and 1 band is from the rod end of a cylinder. Orange = Lift, Green = Tilt, Red = Angle, and Yellow = Angle 2-Stick

1. Connect the lift hoses to the lift cylinders.
2. Verify that hoses are not twisted and protected from rubbing on any sharp edges. See Pages 6-7 for proper hose routing.
3. Attach the multi-coupler to the top arm mount and install the 45° fittings.
4. Identify each remaining hose at the front of the undercarriage by the colored bands on the end of the hose and connect the hose to the corresponding 45° fitting on the multi-coupler. Refer to Pages 6-7 for proper hose locations.
5. Hoses were plugged into the rear of the tractor during the undercarriage installation.
6. Continue on Page 8 for initial startup instructions.

Tractor Side Hydraulics

ITEM NO.	QTY.	PART NO.	DESCRIPTION
1	4	16-18957	5/16" x 3-1/4" Allen Head Screw
2	1	25-19861	Multi-Coupling Plate - 5 Port - Fixed
3	1	25-19863	Multi-Coupling Plate - 5 Port - Cap
4	5	25-19870	Multi-Coupling Plate - Male Coupler
5	2	25-3401	Pioneer Dust Cap Left Angle (Yellow)
6	8	25-34342	Tappet Quick Coupler Male - Poppet Style
7	2	25-3453	Pioneer Dust Cap Tilt (Green)
8	2	25-3455	Pioneer Dust Cap Angle (Red)
9	2	25-3457	Pioneer Dust Cap Lift (Orange)
10	5	25-40407	Multi-Coupling Plate - Snap Ring
11	2	31-11699-10-10	JIC Union
12	5	31-15199-8-8	JIC Union Elbow 90°
13	2	31-34032	Bulkhead Run Tee JIC
14	4	31-34042	Straight JIC x O-Ring
15A,B	6	31-34051	Straight Thread Elbow 90° JIC x O-Ring
15C	6	31-6802-08-10	Straight Thread Elbow 45° JIC x O-Ring
16A,B	2	31-34059	Straight Thread Elbow 90° JIC x O-Ring
16C	2	31-6802-12-10	Straight Thread Elbow 45° JIC x O-Ring
17	1	31-34090	Swivel Nut Run Tee JIC
18	1	31-34100	Swivel Nut Elbow 90° JIC
19	5	31-34150	Straight Thread Elbow 45° JIC x O-Ring
20	2	34-12932	Cylinder Saddle
21	2	34-12933	Hose Clamp (worm drive - 4.5)
22	9	34-18888-GR	-12 Green - Spiral Band

*Parts Not Shown

Hoses Not Drawn to Scale

Item A for CNH, JD 9R, JD 9030

Item B for Versatile, Challenger MT900, and JD 9RX

Item C for Claas Xerion Tractor

Every hydraulic function from the front to the back of the system is designated by a \odot and a letter and can also be referenced on the Hydraulic Schematics on Page 21.

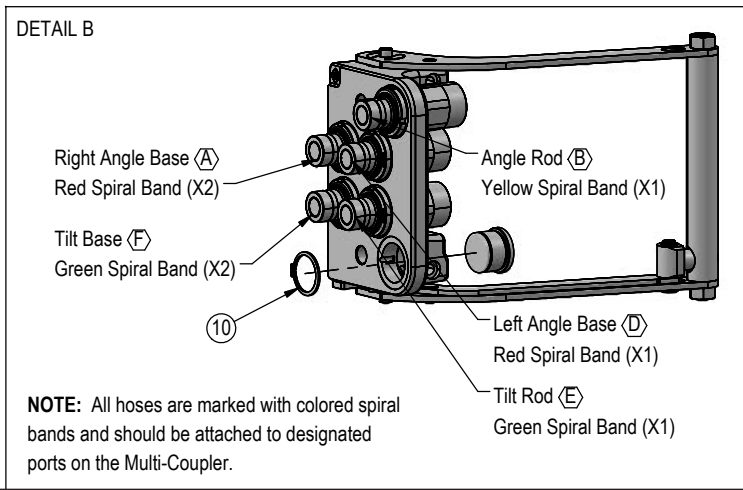
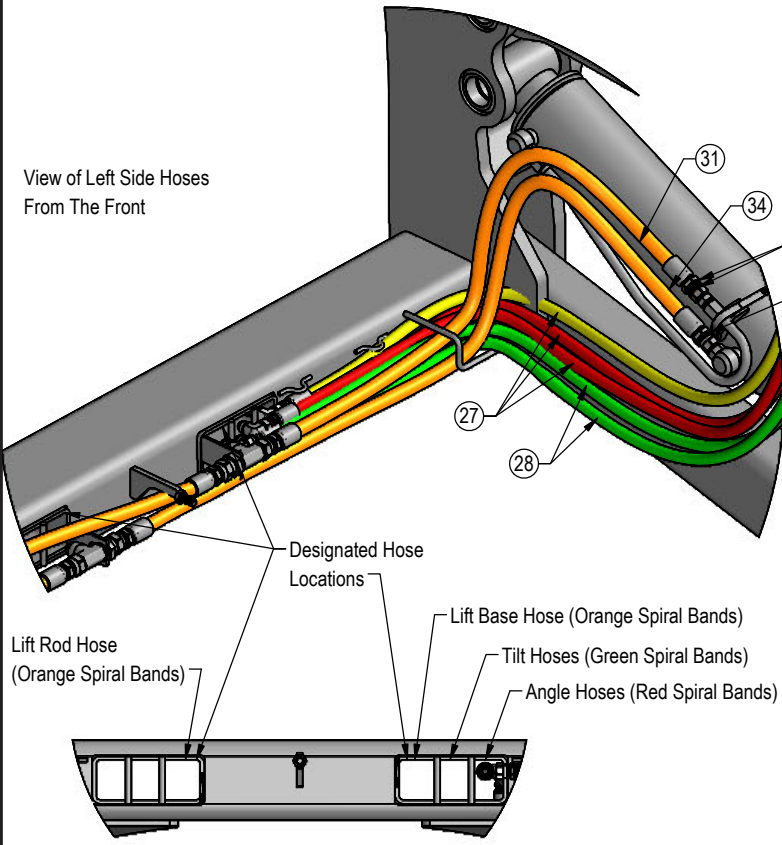
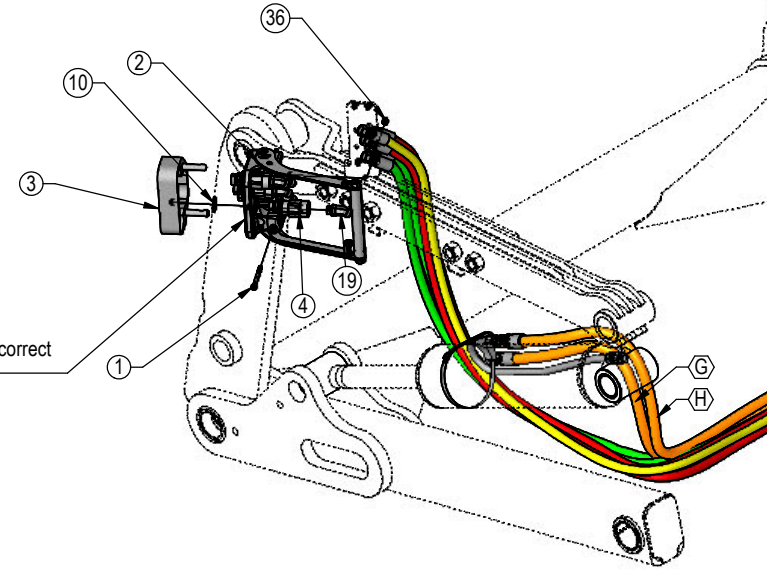
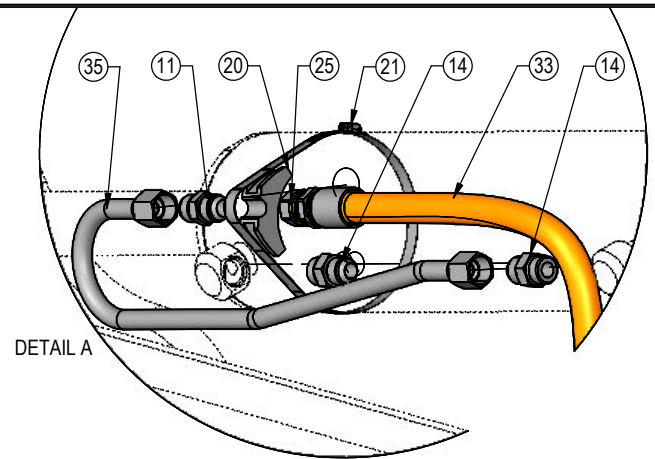

ITEM NO.	QTY.	PART NO.	DESCRIPTION
23	10	34-18888-RD	-12 Red - Spiral Band
24	4	34-18888-YL	-12 Yellow - Spiral Band
25	15	34-19494-OR	-16 Orange - Spiral Band
26	1	35-12631-0350	35" x 1/2" -8JIC / -8JIC Abrasion Resistant Hose
27	3	35-12631-0780	78" x 1/2" -8JIC/-8JIC Abrasion Resistant Hose
28	2	35-12631-0810	81" x 1/2" -8JIC/-8JIC Abrasion Resistant Hose
29A,C	5	35-12631-2930	293" (24.42") x 1/2" -8JIC/-8JIC Abrasion Resistant Hose
29B	5	35-12631-3200	320" (26.67") x 1/2" -8JIC/-8JIC Abrasion Resistant Hose
30A,C	2	35-12637-2930	293" (24.42") x 3/4" -12JIC/-12JIC Abrasion Resistant Hose
30B	2	35-12637-3200	320" (26.67") x 3/4" -12JIC/-12JIC Abrasion Resistant Hose
31	1	35-12641-0515	51.5" x 5/8" -10JIC/-12JIC Abrasion Resistant Hose
32	1	35-12641-0535	53.5" x 5/8" -10JIC/-12JIC Abrasion Resistant Hose
33	1	35-12641-0665	66.5" x 5/8" -10JIC/-12JIC Abrasion Resistant Hose
34	1	35-12641-0670	67" x 5/8" -10JIC/-12JIC Abrasion Resistant Hose
35	2	35-18240	Lift Cylinder Steel Line
36	4	70-20611	5/16" Nyloc Hex Nut Gr. 5
37	2	70-20809	1-1/16" Hex Jam Nut

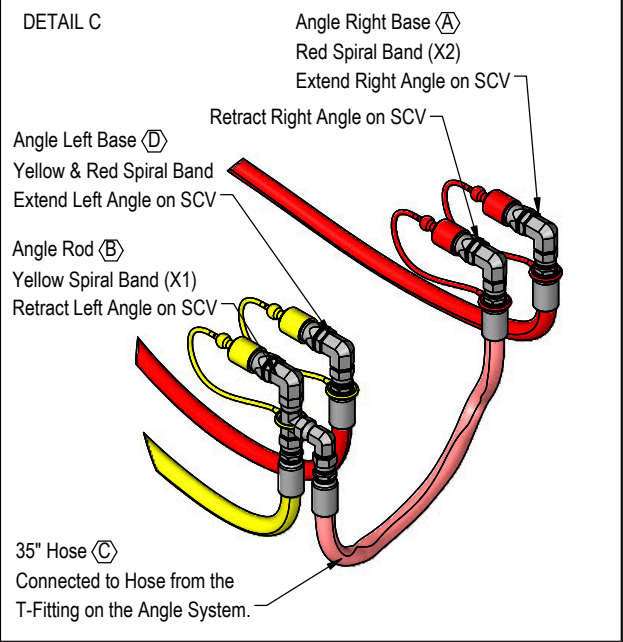
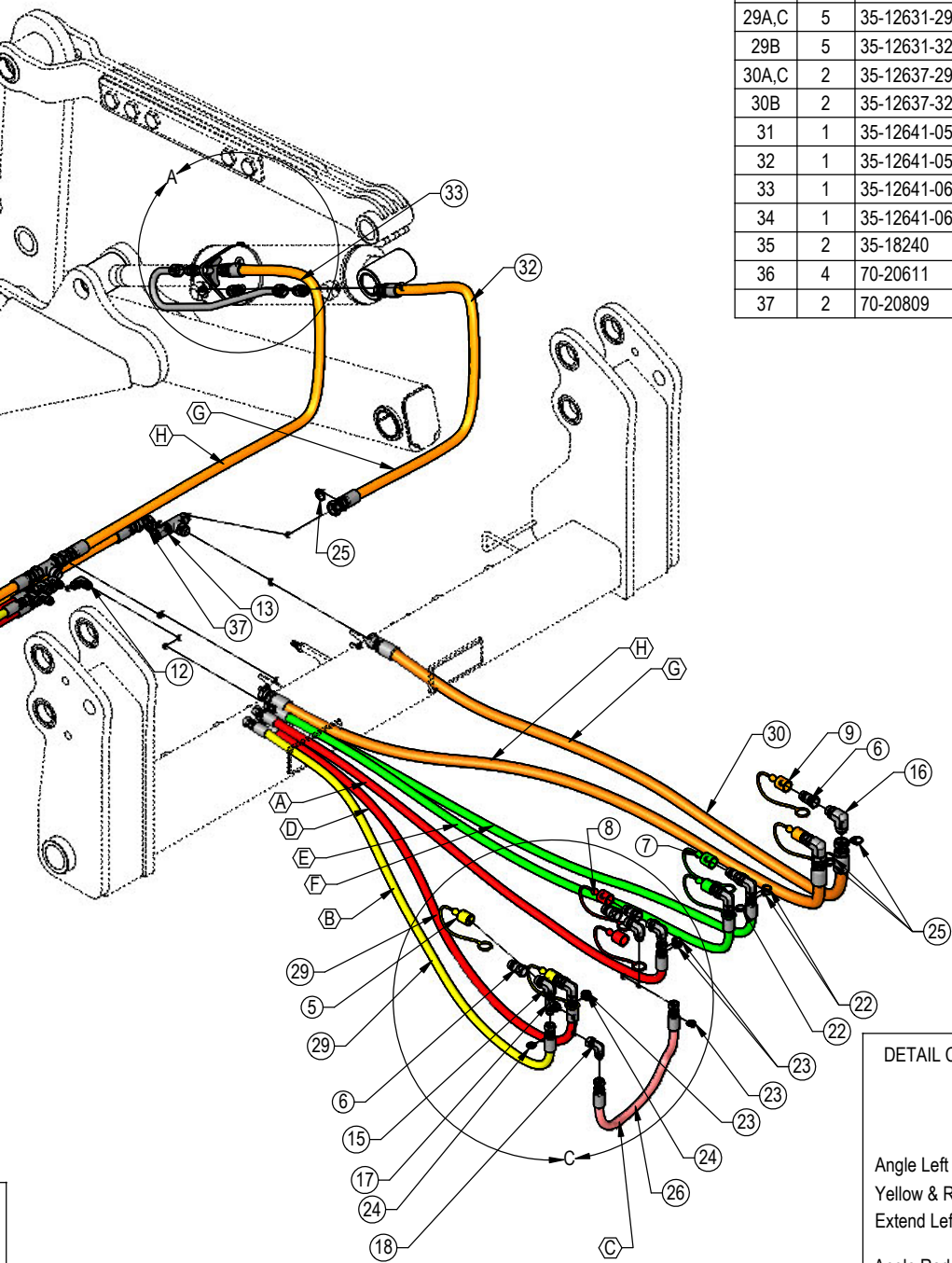

Prior to operating the blade system, all air must be purged from the hydraulic system. Follow the steps below for each function on your blade.

Lift Function:

1. With the lift frame down and blocked, loosen the fittings on both ends of the lift cylinders.
2. Actuate the raise function to supply oil to the rod end of the cylinders.
3. When oil starts to flow from the fittings, stop oil flow, and tighten the fitting on the rod end of the lift cylinders.
4. Continue to flow oil until the system is fully raised and then block the lift frame.
5. Actuate the function in the opposite direction to supply oil to the base end of the lift cylinders.
6. When all air is removed from the lift system, stop oil flow and tighten the fittings on the base end of the lift cylinders.
7. Raise lift system and remove blocks. Cycle up and down 5 more times.
8. Check tractor oil level and fill if necessary.
9. Continue with connecting the blade on Page 10.

Tilt Function:

1. Use a lift or jack to tilt the blade system until the left side is fully up, loosen the fittings on the rod and base end of both tilt cylinders.
2. Actuate the tilt function to extend the right tilt cylinder and supply oil to the base end of the right cylinder and to the rod end of the left cylinder.
3. When oil starts to flow from the fittings, stop oil flow, and tighten the fitting on the base end of the right cylinder and rod end of the left cylinder.
4. Remove the lift or jack.
5. Continue to actuate the tilt function until oil flows out of the remaining open ports.
6. Actuate the tilt function in the opposite direction.
7. When all air is removed from the tilt system, stop oil flow, and tighten the remaining fittings on the cylinders.
8. Cycle both cylinders in and out 5 more times.
9. Check tractor oil level and fill if necessary.

Angle Function:

1. Loosen the fittings on the rod and base end of the left angle cylinder.
2. Actuate the angle function to extend the left angle cylinder and supply oil to the base end of the left cylinder.
3. When oil starts to flow from the fittings, stop oil flow, and tighten the fitting on the base end of the left cylinder.
4. Continue to actuate the left angle function in the same direction until the cylinder is fully extended.
5. Actuate the left angle function in the opposite direction.
6. When oil starts to flow from the rod end fitting, stop oil flow, and tighten the rod end fitting on the left angle cylinder.
7. Continue to actuate the left angle function until cylinder is fully retracted.
8. Loosen the fittings on the rod and base end of the right angle cylinder.
9. Actuate the angle function to extend the right angle cylinder and supply oil to the base end of the right cylinder.
10. When oil starts to flow from the fittings, stop oil flow, and tighten the fitting on the base end of the right cylinder.
11. Continue to actuate the right angle function in the same direction until the cylinder is fully extended.
12. Actuate the right angle function in the opposite direction.
13. When oil starts to flow from the rod end fitting, stop oil flow, and tighten the rod end fitting on the right angle cylinder.
14. Continue to actuate the right angle function until cylinder is fully retracted.
15. Cycle the left cylinder in and out 5 more times and then the right cylinder in and out 5 more times.
16. Check tractor oil level and fill if necessary.

Run the blade through all the functions. If any function does not operate correctly, refer to corresponding section above and re-bleed. If problem still persists, call Grouser Products.

With the **Electric Hydraulic Angle Option**, you will have the ability to angle the blade 30 degrees left or right. To achieve these angles, the two cylinders are designed to operate independently of each other through an electric diverter valve. To angle the blade to the left, actuate the tractor hydraulic control lever in the cab with the diverter valve un-powered. To angle the blade to the right, apply power to the diverter valve and then actuate the tractor hydraulic control lever.

The safety relief valve allows the cylinder to retract if its internal pressure becomes excessive. With this safety feature in place, when either cylinder reaches the end of its stroke, the safety relief valve will reroute pressure to the opposite cylinder causing it to extend. If this occurs, refer to the Relief Valve adjustment below for possible adjustments. Only one cylinder should be extended when angled dozing.

With the **2-Stick Hydraulic Angle Option**, you will have the ability to angle the blade 30 degrees left or right. To achieve these angles, the two cylinders are designed to operate independently of each other with the use of 2 tractor hydraulic control levers and a safety relief valve. To angle the blade to the left or right, actuate the tractor hydraulic control lever corresponding to the left or right cylinder.

To ensure proper use and life of equipment, it is recommended to have both cylinders closed for straight ahead dozing and only one cylinder partially or fully extended for angled dozing as shown in the diagrams below. If the angle system is not used correctly, frame damage may occur. Diagrams below may look slightly different than your system, but the information is still compatible and important to your system.

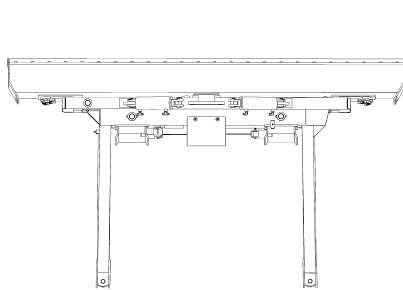

CORRECT

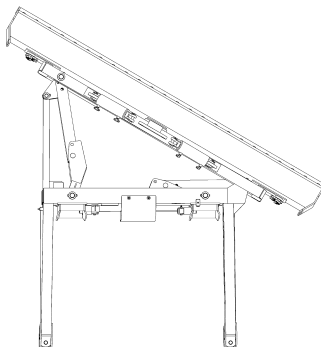

CORRECT
(Left or Right)

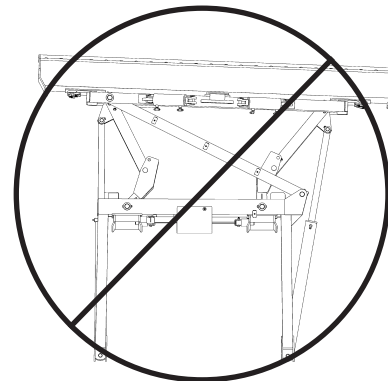

Incorrect

When either angle cylinder reaches the end of its stroke and the safety relief valve reroutes pressure to the opposite cylinder causing it to extend, adjust the relief valve. To set the electric safety relief valve at a higher pressure than tractor: Use a pressure gauge connected between the tractor pump and the port A on the electric relief valve on the blade to check the tractor pressure and record the reading. To increase the pressure of the relief valve, install a 0-5,000 psi pressure gauge between the hose and fitting in the base end of right angle cylinder. Make sure both angle cylinders are retracted. Loosen the jam nut on the valve system relief cartridge. Next, start tractor and extend the right side cylinder out until the safety valve activates, while the safety valve is in function (pressure being rerouted to opposite cylinder causing opposite cylinder to extend), record the pressure reading on the gauge. Tighten the Allen screw in small increments and record the pressure until the pressure is about 50-100 psi higher than the tractor pressure. Do not exceed the 3,500-psi operating pressure of the cylinders. Tighten the jam nut and remove the gauge.

CAUTION: Do not bypass the safety relief valve and plumb each cylinder to separate valves on the tractor.

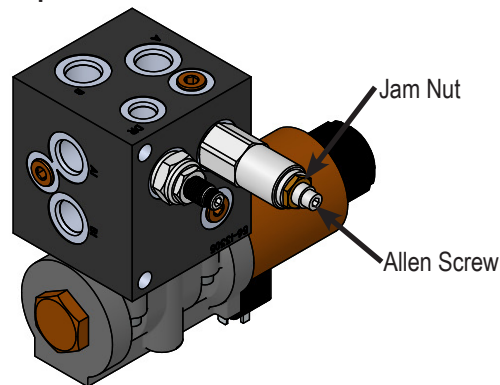

To Connect:

Note: If necessary, use a spotter to help center the blade on the lift system.

1. Before standing blade upright for initial connection, remove the 3/4" pin (#20 on Page 12) so the skid shoes can move freely. The blade will lean back further for easier connection. Store the pin in the storage location (See Page 11 for location).
2. If necessary, lift the locking latch and pull the quick attach lock handle on the left side of the lift system to open the quick attach system. Refer to Page #14-15 for further clarification on the quick attach system.
3. Drive the tractor forward slowly until the top edge of the male quick attach is under the top hook of the female quick attach on the blade assembly.
4. Raise the lift system until the male quick attach engages the female hook. If both sides don't fully engage, reposition. Continue to raise the lift system until the blade is off the ground and the female quick attaches are against the front of the male quick attaches.
5. Shut off the tractor engine and set the parking brake.
6. Push the quick attach lock handle to engage the quick attach pins and lift the locking latch to lock the handle in place.
7. Clean and connect hydraulic multi-coupler on the top arm. Refer to Pages 18-19 for cleaning and connecting information.
8. If applicable, plug the male blade break away end of the wire harness into the female blade break away end of the wire harness on the top arm.
9. Lock the mushroom skid shoe link back in place with the 3/4" pin you removed in Step #1.
10. If initial startup, refer to Page 8 before operating any function of the blade.

To Disconnect:

1. Lower the blade until the cutting edge is off the ground a few inches.
2. Shut off the tractor engine and set the parking brake.
3. Unhook the multi-coupler on the top arm.
4. Remove the multi-coupler cover from the parking station on the blade assembly and install on the multi-coupler on the top arm.
5. Plug the blade side multi-coupler into the parking station.
6. Lift the locking latch and pull the quick attach lock handle to disengage the quick attach pins.
7. Remove the 3/4" pin so the skid shoes can move freely and the blade can lean back. Store the pin.
8. Start tractor, disengage the parking brake, and lower the blade until cutting edge is on the ground.
9. Continue to slowly lower the lift system to disengage the blade.
10. Slowly back away from the blade. When lift system is clear from the blade, raise the lift system.
11. Shut off the tractor engine and set the parking brake.

Skid Shoe Adjustment:

1. Remove the handle from the ratchet keeper by pulling the hitch clip pin and insert it into the handle receiver on the ratchet jack.
2. Loosen the locking nut on the ratchet jack.
3. Hold the body of the ratchet jack and rotate the ratchet jack handle to raise or lower the skid shoes.
4. If the skid shoe is not moving in the proper direction, flip the forward/reverse lever on the handle (see Figure 2). Rotate the ratchet jack handle again to move the skid shoe in the desired direction.
5. After the skid shoe is adjusted, rotate the ratchet jack handle until it rests against the ratchet keeper. Return the removable handle to the ratchet keeper ensuring that the ratchet jack handle is captured by the removable handle and the ratchet keeper. Secure the handle to the ratchet keeper with the hitch clip pin.
6. Tighten the locking nut against the ratchet jack body to keep it from moving.
7. When skid shoes are worn up to the bolt heads, replace skid shoes.

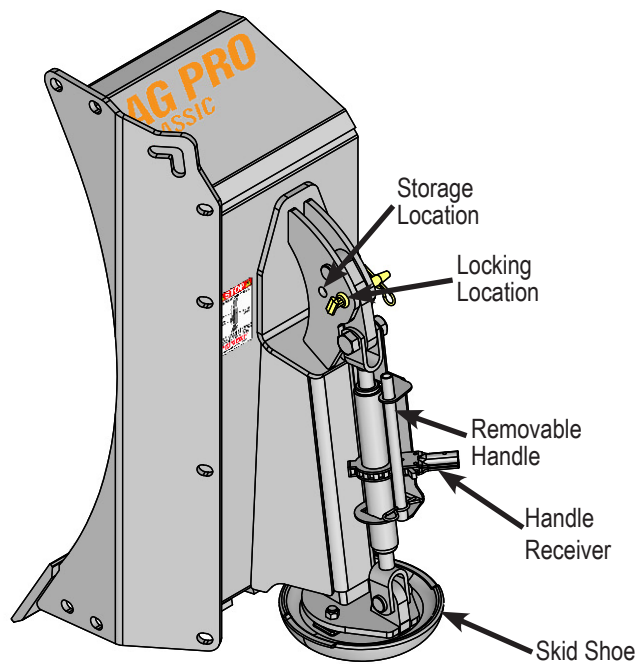

Figure 1

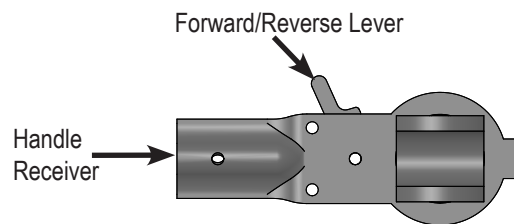

Figure 2

Preferred Method:

1. The preferred blade position for adjusting the tilt plates is laying face down on blocks.
2. Remove the 6 bolts from the right tilt plates.
3. Add or remove washers as needed to adjust tilt-way clearance to 1/16" - 1/8".
4. Reinstall the bolts in the right tilt plates.
5. Follow Steps #2-4 for the left tilt plates.
6. Once the tilt-way clearance is set, torque bolts to 640 ft-lbs.

Non-Preferred Method:

Note: Do not remove all of the bolts at the same time if the blade is not laying face down.

1. The non-preferred blade position for adjusting the tilt plates is the blade in the upright position.
2. Remove the 3 bolts from the top right tilt plate and the bottom left tilt plate..
3. Add or remove washers as needed to adjust tilt-way clearance to 1/16" - 1/8".
4. Reinstall the bolts in the top right tilt plate and the bottom left tilt plate.
5. Follow Steps #2-4 for the bottom right tilt plate and the top left tilt plate.
6. Once the tilt-way clearance is set, torque bolts to 640 ft-lbs.

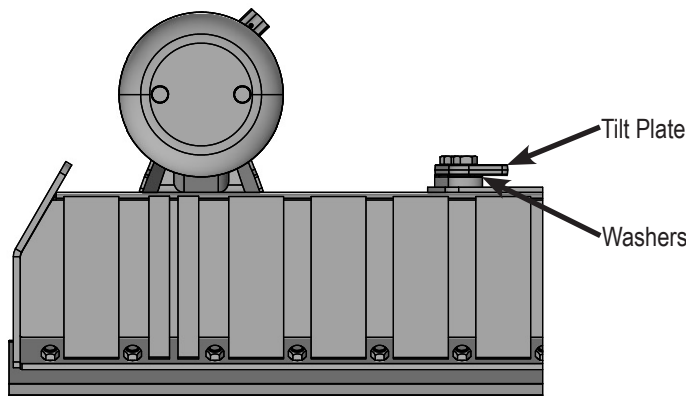

ITEM NO.	PART NO.	14'/QTY.	16'/QTY.	18'/QTY.	DESCRIPTION
1	15-19110-14	1	-	-	HD Blade Weld
2	15-19110-16	-	1	-	HD Blade Weld
3	15-19110-18	-	-	1	HD Blade Weld
4	15-18520-14	1	-	-	Top Extension Weld
5	15-18520-16	-	1	-	Top Extension Weld
6	15-18520-18	-	-	1	Top Extension Weld
7	16-18945	2	2	2	1" x 3" Hex Bolt Gr 5 NC - Short Thread
8	16-20538	14	18	18	7/8" x 2" Hex Bolt Gr 8 NC
9	16-20562	12	12	12	1" x 3" Hex Bolt Gr.8 NC
10	16-20568	3	3	3	1" x 5" Hex Bolt Gr.8 NC
11	16-21064	8	8	8	3/8" x 1" Carriage Bolt Gr 5 NC
12	16-21666	4	4	4	5/8" x 1-3/4" Plow Bolt Gr 5 NC
13	16-21752	36	40	44	3/4" X 2" Plow Bolt Gr 8 NC
14	18-18498-L	1	1	1	Ratchet Keeper - Left
15	18-18498-R	1	1	-	Ratchet Keeper - Right
16	27-14842-14	1	-	-	14' Decal
17	27-14842-16	-	1	-	16' Decal
18	27-14842-18	-	-	1	18' Decal
19	27-14845	1	1	1	Ag Pro Blade Decal
20	NA	1	1	1	Grouser Dozer Metal Serial Tag
21	27-40917	1	1	1	Ratchet Holder Storage Decal

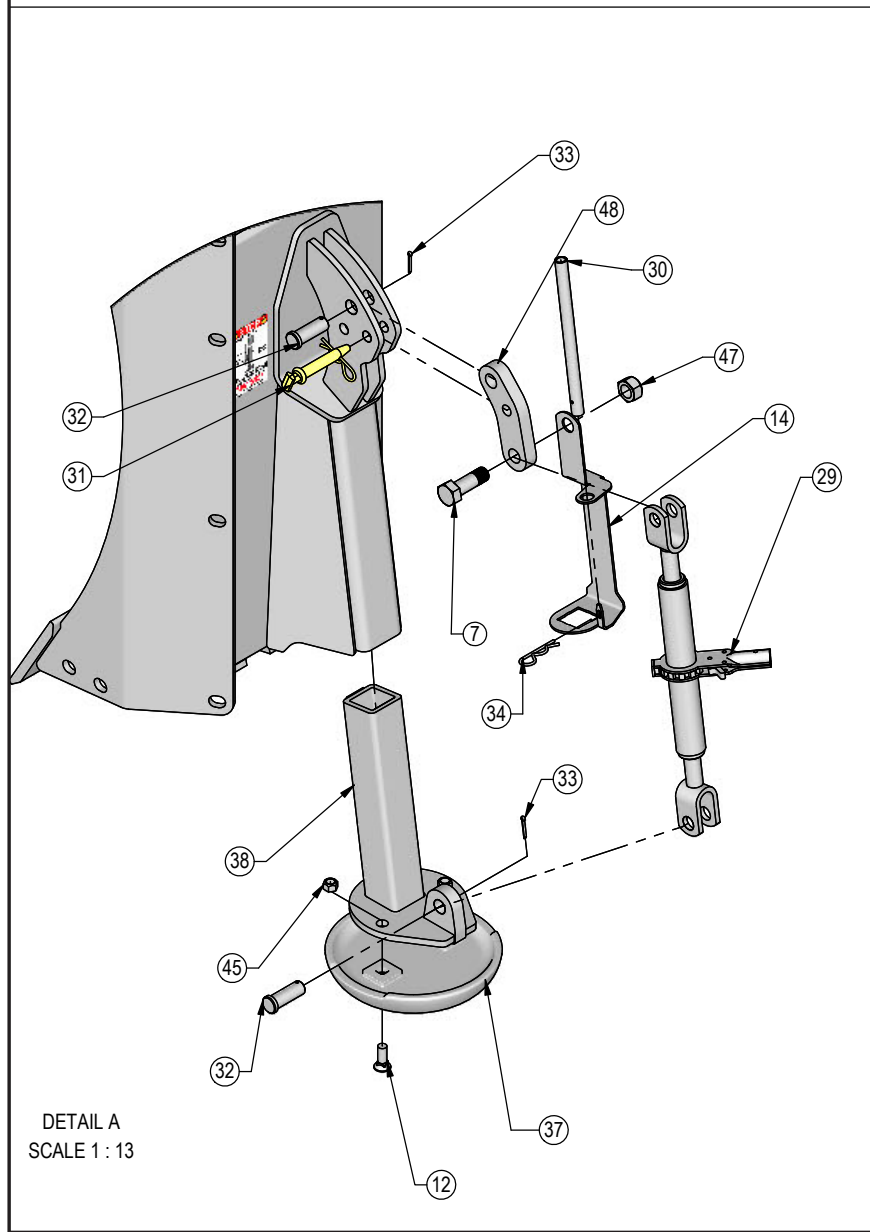

DETAIL A
SCALE 1 : 13

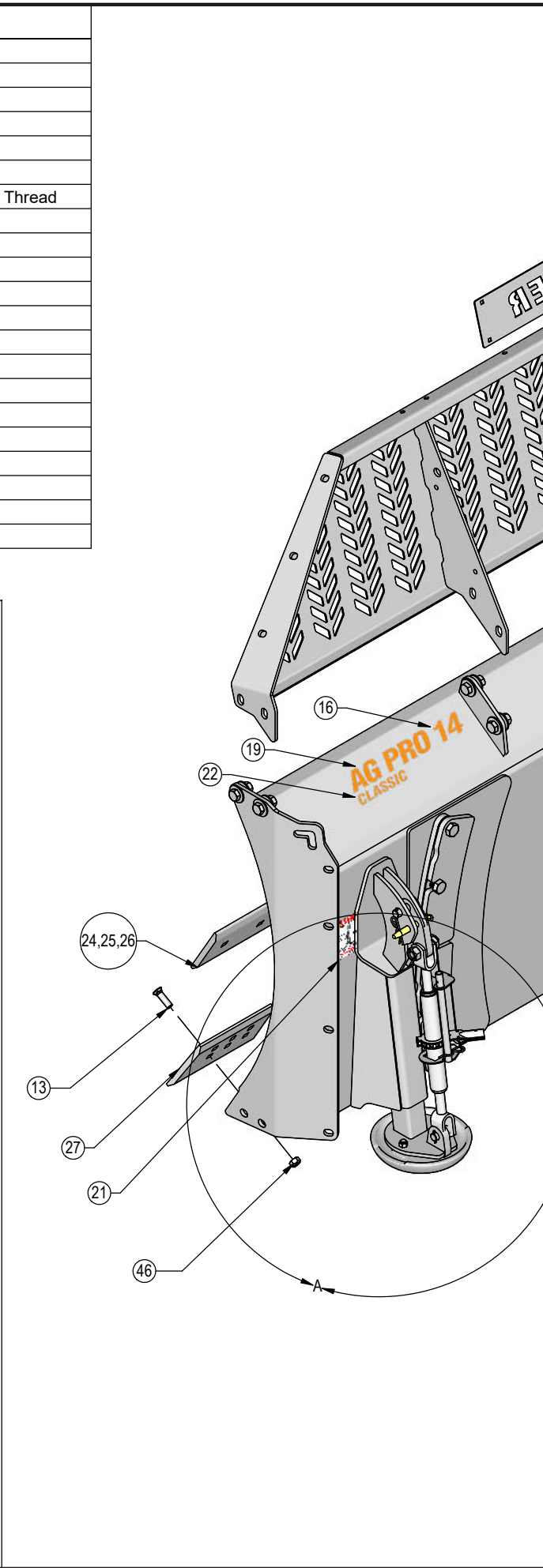

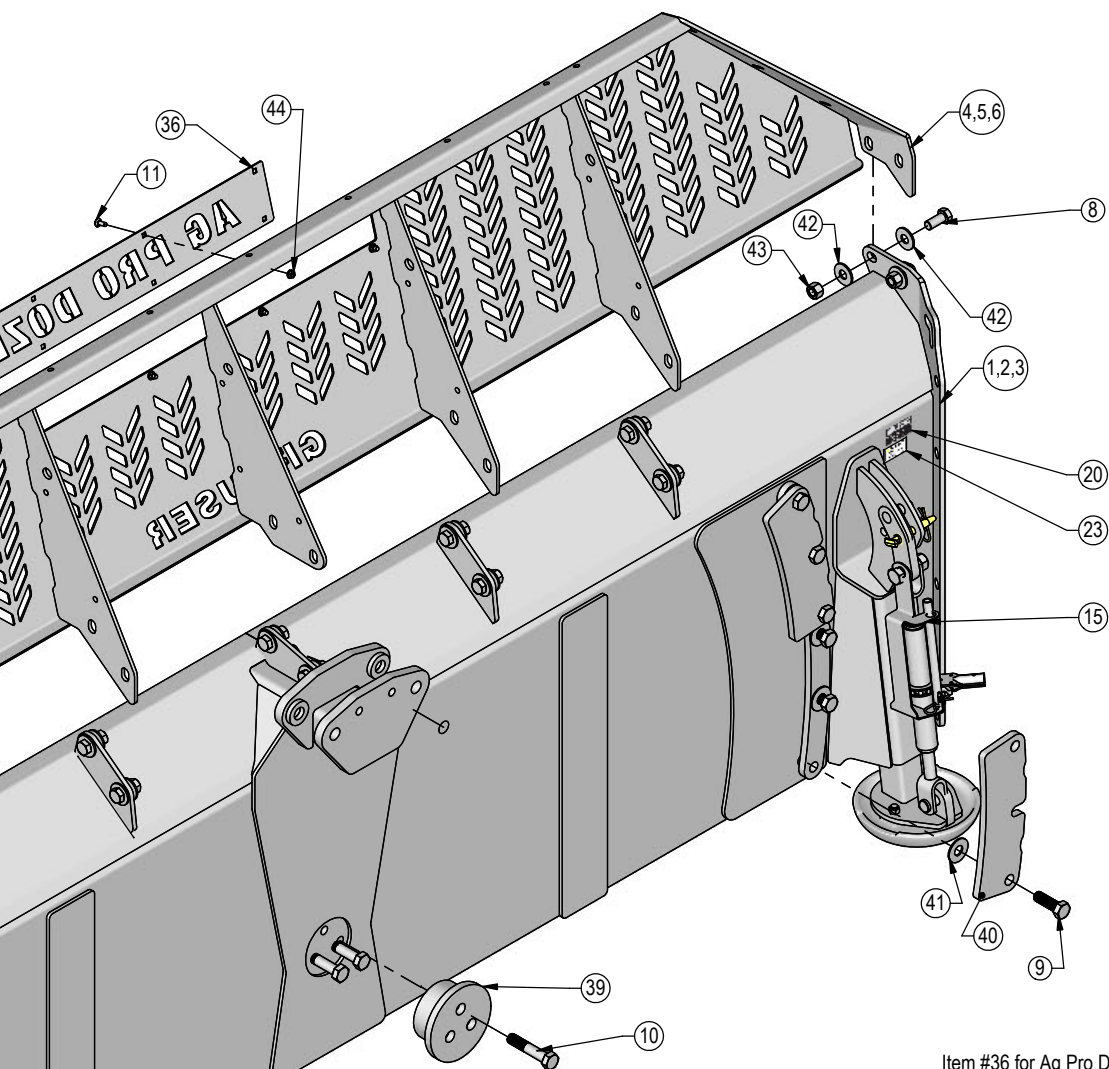

Item #36 for Ag Pro Dozer Name Plate and Item #35 for Custom Name Plate

ITEM NO.	PART NO.	14'/QTY.	16'/QTY.	18'/QTY.	DESCRIPTION
22	27-40951	1	1	1	Classic Decal
23	27-40962	1	1	1	Warning Prop 65 Decal
24	29-11118-6	2	-	-	6' - 3/4" x 8" Cutting Edge
25	29-11118-7	-	2	-	7' - 3/4" x 8" Cutting Edge
26	29-11118-8	-	-	2	8' - 3/4" x 8" Cutting Edge
27	29-19116-R,L	1	1	1	8" End Bit
28	29-19116-R,L	1	1	1	8" End Bit
29	34-17565	2	2	2	Skid Shoe Ratchet Jack
30	34-17567	2	2	2	Handle, Ratchet Jack
31	43-15712	2	2	2	3/4" x 3-1/4" Pin with Hitch Pin Clip
32	43-18463	4	4	4	1" x 2.75" Pin
33	43-18943	4	4	4	3/16" x 1-1/2" Cotter Pin
34	43-7767	2	2	2	Cylinder Pin Clip
35	44-14830	1	1	1	Custom Name Plate
36	44-15150	1	1	1	Ag Pro Dozer Name Plate
37	50-15458	2	2	2	12" Round Mushroom Skid Shoe
38	50-18470	2	2	2	Mushroom Skid Shoe Mount
39	52-12380R1	1	1	1	Center Tilt Way Cover
40	52-18299	4	4	4	Tilt Plate
41	57-20749	12	12	12	1" Flat Washer
42	57-20818	28	36	36	7/8" Flat Washer Heavy Duty Gr 8 (USS)
43	70-20598	14	18	18	7/8" Hex Nut Gr 8 NC
44	70-20622	8	8	8	3/8" Flange Hex Nut Gr 5 NC
45	70-20646	4	4	4	5/8" Hex Top Lock Nut Gr 5 NC
46	70-20647	36	40	44	3/4" Hex Top Lock Nut Gr 5 NC
47	70-20999	2	2	2	1" Hex Top Lock Nut Gr 8 NC (YZ)
48	75-18479	2	2	2	Skid Shoe Link

Hydraulic Angle-Hydraulic Tilt System

ITEM NO.	QTY.	PART NO.	DESCRIPTION
1	1	11-12397	Stabilizer Arm
2	1	11-19685	Angle Arm Assembly-R
3	1	11-19690	Angle Arm Assembly-L
4	1	11-40866	Bell Crank
5	1	16-20011	1/4" x 2-3/4" Hex Bolt Gr 5 NC
6	2	16-20130	1/2" x 2-1/2" Hex Bolt Gr 5 NC
7	4	16-20132	1/2" x 3" Hex Bolt Gr 8 NC
8	2	16-20424	1/2" x 3-1/2" Hex Bolt Gr 8 NC
9	3	16-20427	1/2" x 4-1/2" Hex Bolt Gr 8 NC
10	8	16-20560	1" x 2-1/2" Hex Bolt Gr 8 NC
11	2	16-21065	3/8" x 1-1/4" Carriage Bolt Gr 5 NC
12	4	16-21126	1/2" x 1-1/2" Carriage Bolt Gr 5 NC
13	2	19-40440	.378" ID x .503" OD x .375" Spacer
14	2	27-2409	Pinch Decal (Hand)
15	2	27-9503	Pinch Decal (Foot)
16	2	27-9504	Grouser Horizontal Decal

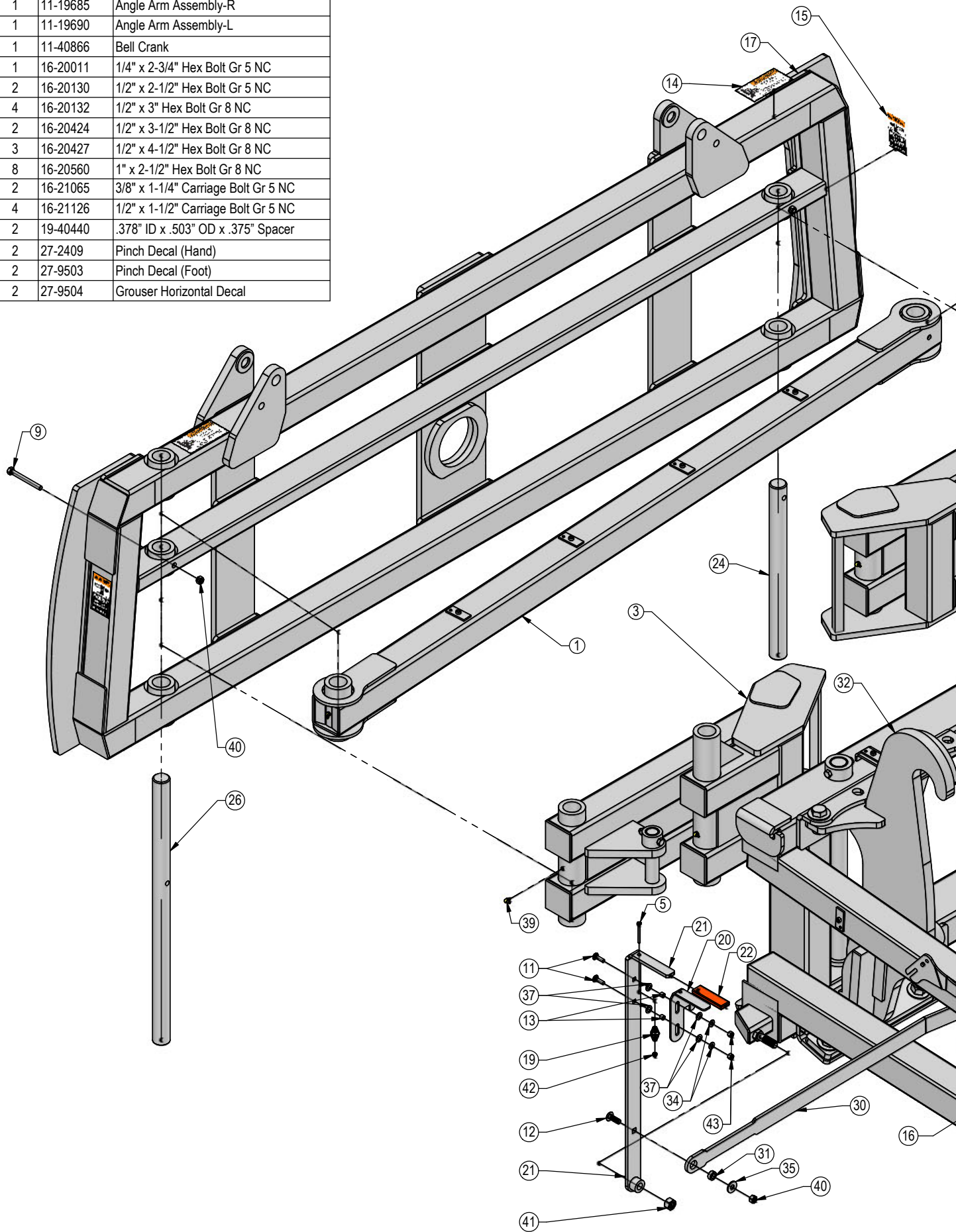

ITEM NO.	QTY.	PART NO.	DESCRIPTION
17	1	32-18265	HA Tilt Frame
18	1	32-19675	Angle Frame
19	1	34-17799	Latch Spring
20	1	39-14663	Latch
21	1	39-14665	Handle Weld
22	1	39-3072	Rubber Handle
23	2	43-18486	AG Pro SS QA Lock Pin
24	1	43-8130	1-15/16" X 23-1/4" NR Pin
25	2	43-8131	1-15/16" X 31" NR Pin
26	1	43-8132	1-15/16" X 35-1/2" NR Pin
27	1	43-8133	1-15/16" X 7-1/8" NR Pin
28	2	43-8134	1-1/2" x 8" NR Pin
29	2	43-9352	1-1/2" X 7-1/2" NR Pin
30	1	44-40879	Plate, Link
31	4	44-8490	Spacer
32	1	45-40870-L	SS Bolt in Quick Attach - Left
33	1	45-40870-R	SS Bolt in Quick Attach - Right
34	2	57-20742	3/8" Flat Washer
35	4	57-20744	1/2" Washer
36	16	57-20819	1" Flat Washer Heavy Duty Gr 8
37	4	57-40408	3/8" Flat Nylon Washer
38	2	58-9371	45° 1/8" NPT Grease Fitting
39	6	58-9372	90° 1/8" NPT Grease Fitting
40	15	70-20604	1/2" Hex Center Lock Nut Gr. 2
41	2	70-20607	3/4" Center Lock Hex Nut Gr 2 NC
42	1	70-20610	1/4" Nyloc Hex Nut Gr 5 NC
43	2	70-20612	3/8" Nyloc Hex Nut Gr 5 NC
44	8	70-20999	1" Hex Top Lock Nut Gr 8 NC
45	2	75-40869	Link, Bell Crank To Pin

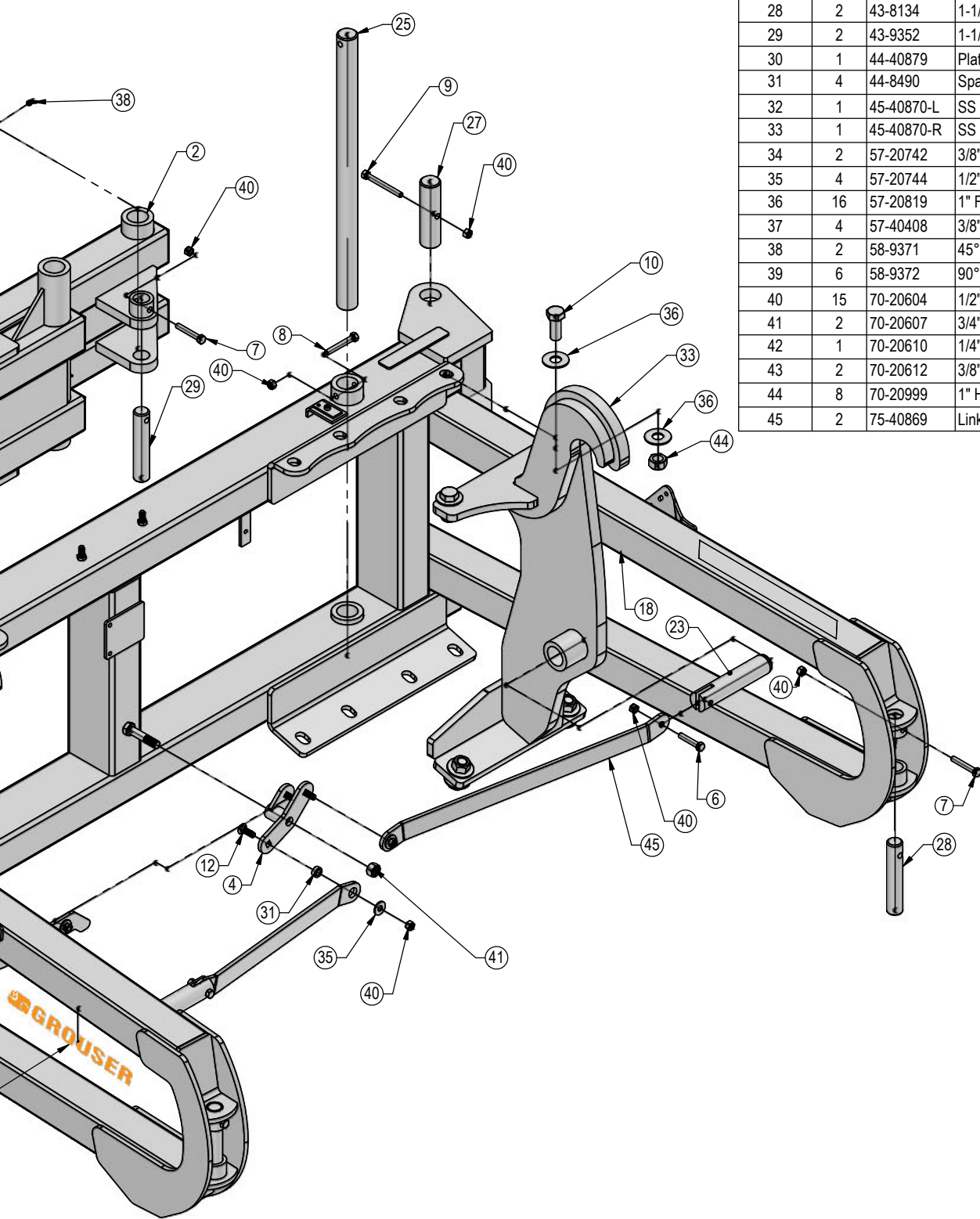

ITEM NO.	QTY.	PART NO.	DESCRIPTION
1	4	16-20034	5/16" x 1" Hex Bolt Gr 5 NC
2	4	16-20035	5/16" x 1-1/4" Hex Bolt Gr. 5
3	4	16-20037	5/16" x 2" Hex Bolt Gr 5 NC
4	4	16-20040	5/16" x 2-1/2" Hex Bolt Gr 5 NC
5	4	16-20220	3/4" x 2-1/2" Hex Bolt Gr 5 NC
6	1	18-14695	Valve Bracket
7	1	18-1701	Valve Cover
8	4	18-19311-02-P-062	Half Hose Clamp
9	1	18-19311-02-P-062	Hose Clamp
10	7	18-19311-03-P-087	Hose Clamp
11	5	18-19312-02	Twin Cover Plate
12	5	18-19312-03	Twin Cover Plate
13	2	18-19313-03	Twin Stacking Bolt
14	2	18-19314-02	Twin Safety Plate
15	4	19-13515	Spacer, NR Pin
16	1	25-18961	Multi-Coupling Plate - 5/6 Port Parking Station
17	1	25-19862	Multi-Coupling Plate - 5 Port - Mobile
18	4	25-19865	Multi-Coupling - Female Coupler
19	4	25-40407	Multi-Coupling - Snap Ring
20	1	25-40413	Multi-Coupling Plate - Cap - Male
21	2	26-34725	4 x 43.5 Cylinder Tube Ends, Top Port
22	2	26-34728	4 x 12 Cylinder Tube Ends
23	1	31-34020	Bulkhead Branch Tee JIC

Note: Every hydraulic function from the front to the back of the system is designated by a \circ and a letter and can also be referenced on the Hydraulic Schematic on Page 21.

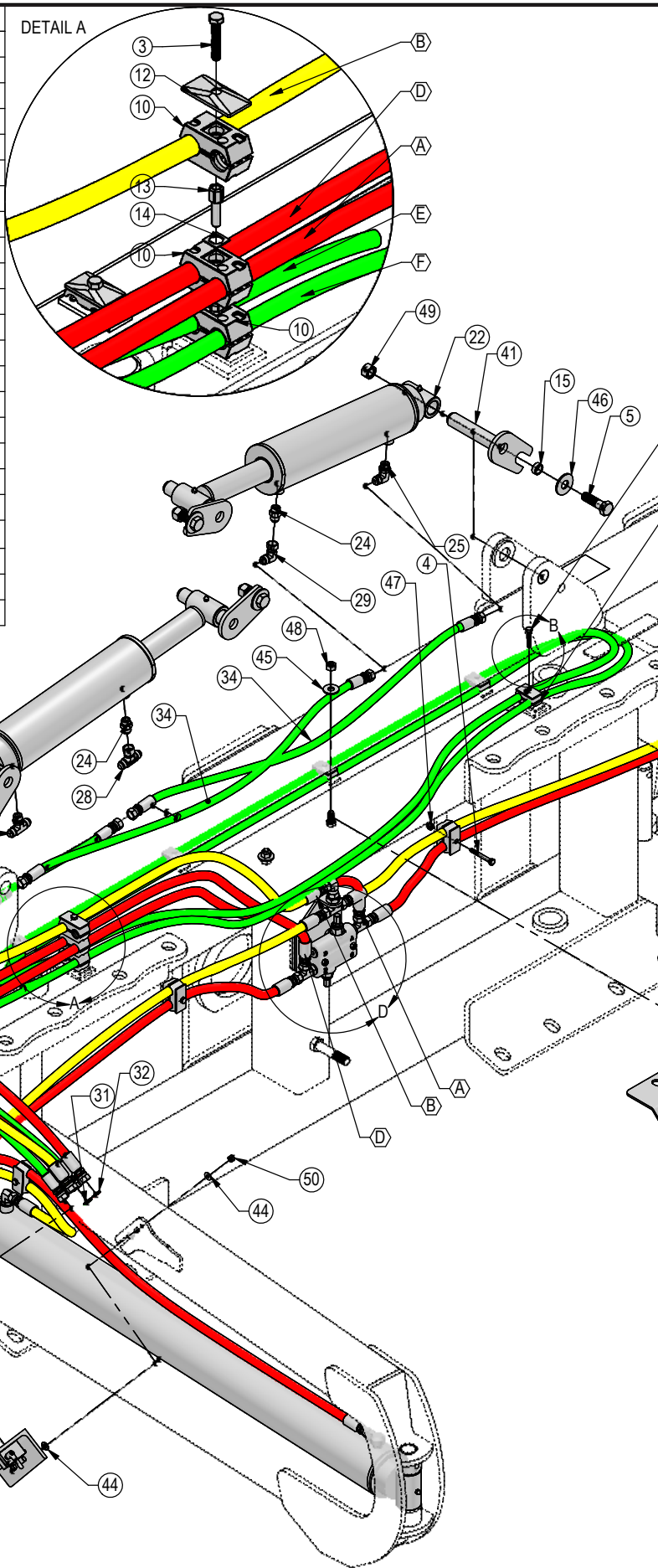

Note: The cylinder part number is stamped on the base end of the cylinder opposite of the hydraulic ports.

No. On Cylinder	Part No.	Description
26-34728	49-12272	Seal Kit 4" (647204) Nitriled Rod
26-34725	49-12274	Seal Kit 4" (647210) Nitriled Rod - Tube Ends

ITEM NO.	QTY.	PART NO.	DESCRIPTION
24	9	31-34040	Straight JIC x O-Ring
25	3	31-34050	Straight Thread Elbow 90° JIC x O-Ring
26	1	31-34060	Branch Tee JIC x O-Ring
27	2	31-34070	Run Tee JIC x O-Ring
28	1	31-34080	Swivel Nut Branch Tee JIC
29	2	31-34100	Swivel Nut Elbow 90° JIC
30	2	31-34123	Hex Socket O-Ring Plug
31	6	34-18888-GR	-12 Green - Spiral Band
32	6	34-18888-RD	-12 Red - Spiral Band
33	2	34-18888-YL	-12 Yellow - Spiral Band
34	2	35-12631-0450	45" x 1/2" -8 FJIC x -8 FJIC Abrasion Resistant Hose
35	2	35-12631-0690	69" x 1/2" -8 FJIC x -8 FJIC Abrasion Resistant Hose
36	1	35-12631-0720	72" x 1/2" -8 FJIC x -8 FJIC Abrasion Resistant Hose
37	2	35-12631-0770	77" x 1/2" -8 FJIC x -8 FJIC Abrasion Resistant Hose
38	2	35-12631-0960	96" x 1/2" -8 FJIC x -8 FJIC Abrasion Resistant Hose
39	1	35-12634-2120	212" x 3/8" -8 FJIC x -8 FJIC Abrasion Resistant Hose
40	1	35-12634-2220	222" x 3/8" -8 FJIC x -8 FJIC Abrasion Resistant Hose
41	4	43-16116R1	Pin Weld
42	1	56-13305	Hydraulic Valve
43	1	56-7772	Valve
44	4	57-20740	1/4" Flat Washer
45	2	57-20744	1/2" Washer
46	4	57-20747	3/4" Flat Washer
47	6	70-20581	5/16" Hex Nut Gr 5 NC
48	2	70-20604	1/2" Hex Center Lock Nut Gr. 2
49	4	70-20607	3/4" Center Lock Hex Nut Gr 2 NC
50	2	70-20611	5/16" Nyloc Hex Nut Gr. 5
51	1	70-20807	3/4" Hex Jam Nut NF

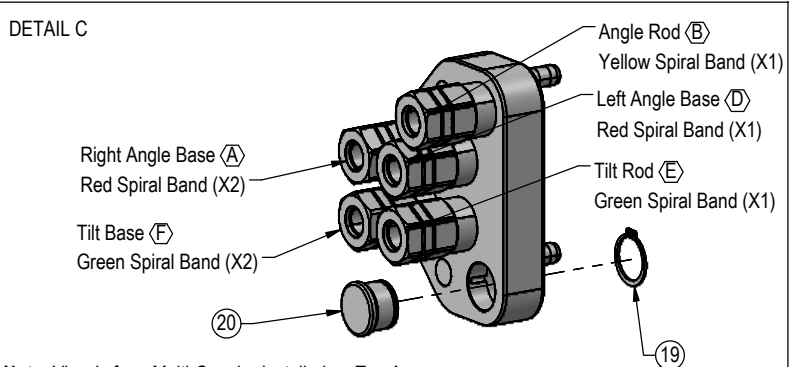
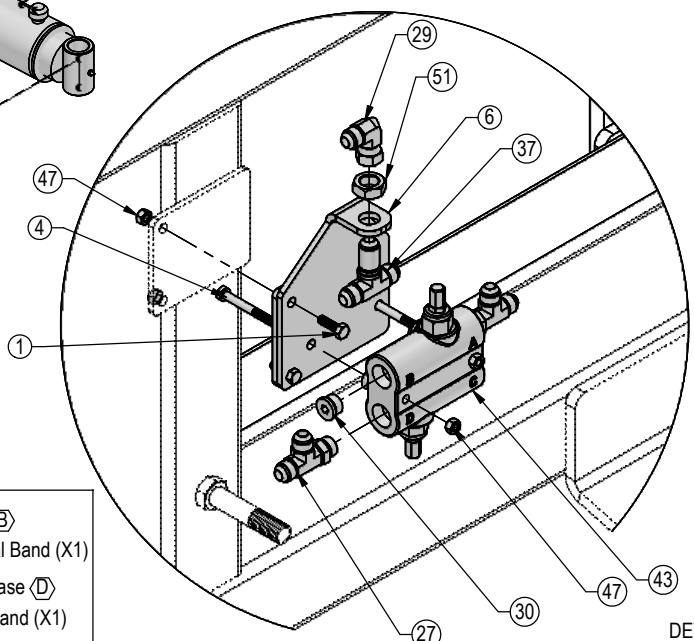
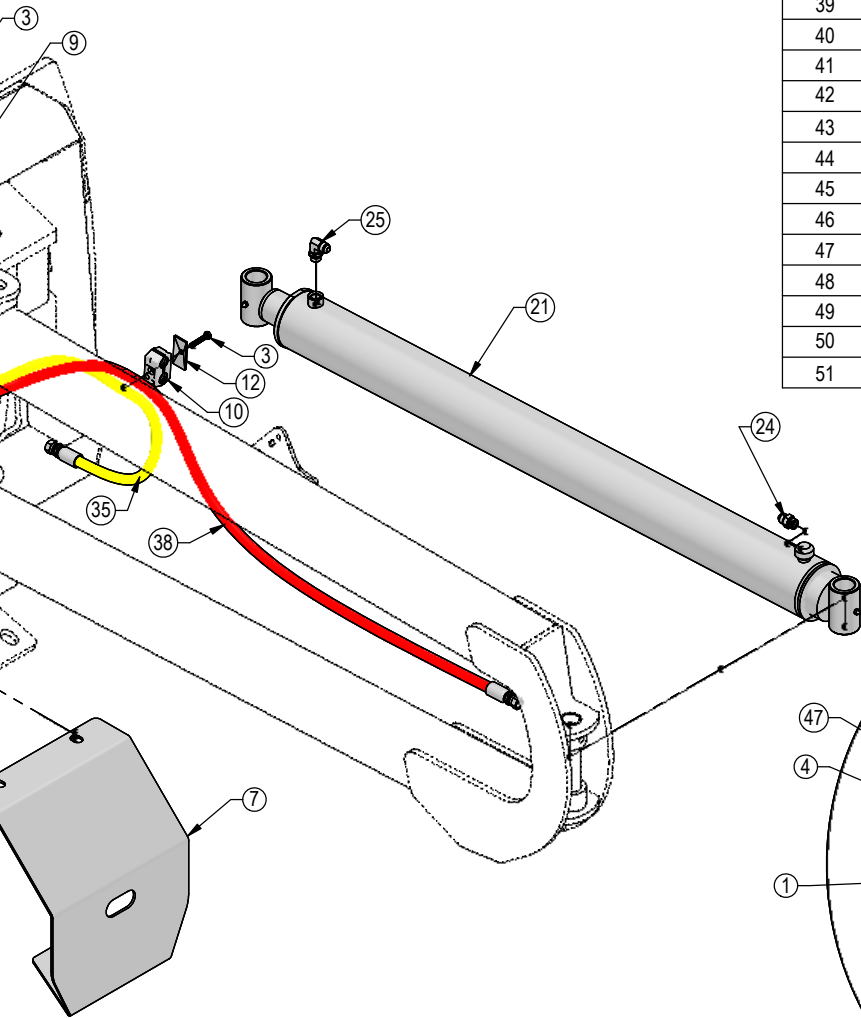
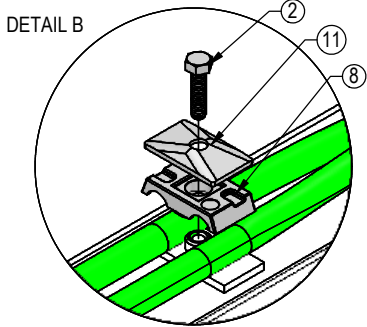

Note: View is from Multi-Coupler Installed on Top Arm.
 All hoses are marked with colored spiral bands and should be attached to designated ports on the Multi-Coupler.

DETAIL D
 SCALE 1 : 7

Before Each Use:

1. Disconnect the mobile half from the parking station and the cap from the fixed half.
2. Check that there is no contamination (salt, sand, dirt, etc.):
 - A. On the pins.
 - B. Inside the cam.
 - C. In the locking mechanism area.
 - D. On the face of the plates and couplings.
3. In case of contamination, remove it with a cloth and/or compressed air.
4. Check that there is still a lubricant/anti-corrosion (grease or silicone - see Note 1):
 - A. On the pins.
 - B. Inside the cam.
 - C. In the locking mechanism area.
5. Connect the mobile and fixed halves together.

Fixed Half

Mobile Half

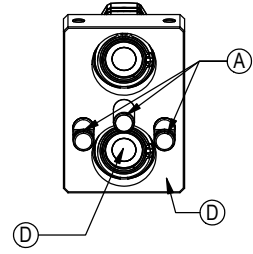
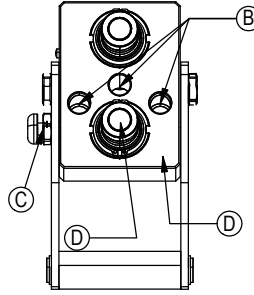

After Each Use:

1. Disconnect the mobile half from the fixed half.
2. Clean all contamination (salt, sand, dirt, etc.) from the following areas:
 - A. On the pins.
 - B. Inside the cam.
 - C. In the locking mechanism area.
 - D. On the face of the plates and couplings.

*Use a cloth or compressed air. It is advised to not use water to clean these surfaces
3. Apply a lubricant/anti-corrosion (grease or silicone - see Note 1):
 - A. On the pins.
 - B. Inside the cam.
 - C. In the locking mechanism area.
4. Connect the cap to the fixed half and the mobile half to the parking station.

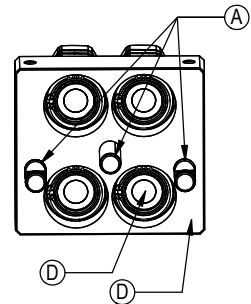
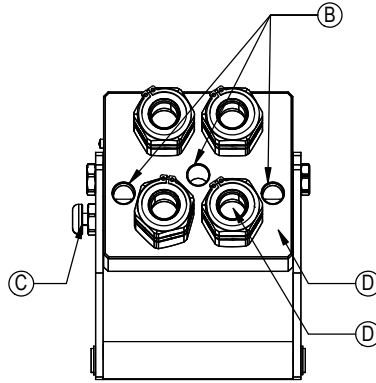

Note 1:

When sand and salt are present, or the plates under go a washdown, a heavy duty silicone spray lubricant should be used to replace grease from the factory. The lubricant should help protect from corrosion without collecting dust and contaminants, and will resist washing off when exposed to water.

Recommended Lubricant Brands:

Fluid Film (Aerosol or Non-Aerosol), LPS-2 Heavy Duty Lubricant, or CRC 3-36.

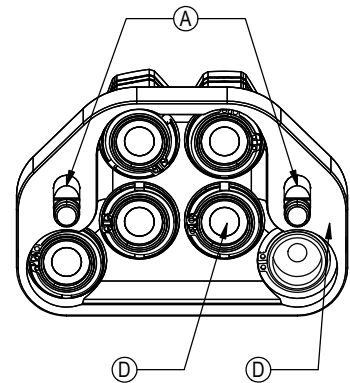
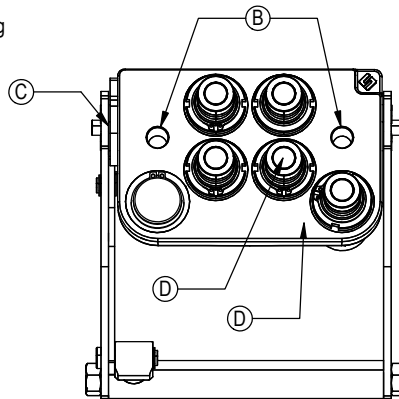

Cleaning The Male Interface Seal:



1. Make sure the coupling is securely fastened into the plate or place in a vice.



2. Using a blunt, non-marring tool, depress the valve face until the seal is exposed. Insert a bent metal wire between the valve face and the body of the coupling. Use caution not to damage or scratch the seal when inserting the wire.



3. Inspect the seal and interior surfaces for contamination.



4. In case of contamination, carefully wipe surfaces with a soft cloth, or use compressed air to blow the contamination out. Do Not press hard on the seal as contamination can scratch the seal surface.



5. Using a non-marring tool, depress the valve face and remove the metal wire. Release the valve to the flush position.

Cleaning The Female Bushing:



1. Make sure the coupling is securely fastened into the plate or place in a vice.



2. Using a non-marring tool, depress the outer ring to expose the bushing. There is no need to expose the valve seal, so stop pressing before the valve is opened.



3. Inspect the interior body and bushing surfaces for contamination.



4. In case of contamination, carefully wipe surfaces with a soft cloth, or use compressed air to blow the contamination out.



5. Release the outer ring so that it returns to the flush position.

Colored Lines = Quantity of Colored Spiral Bands

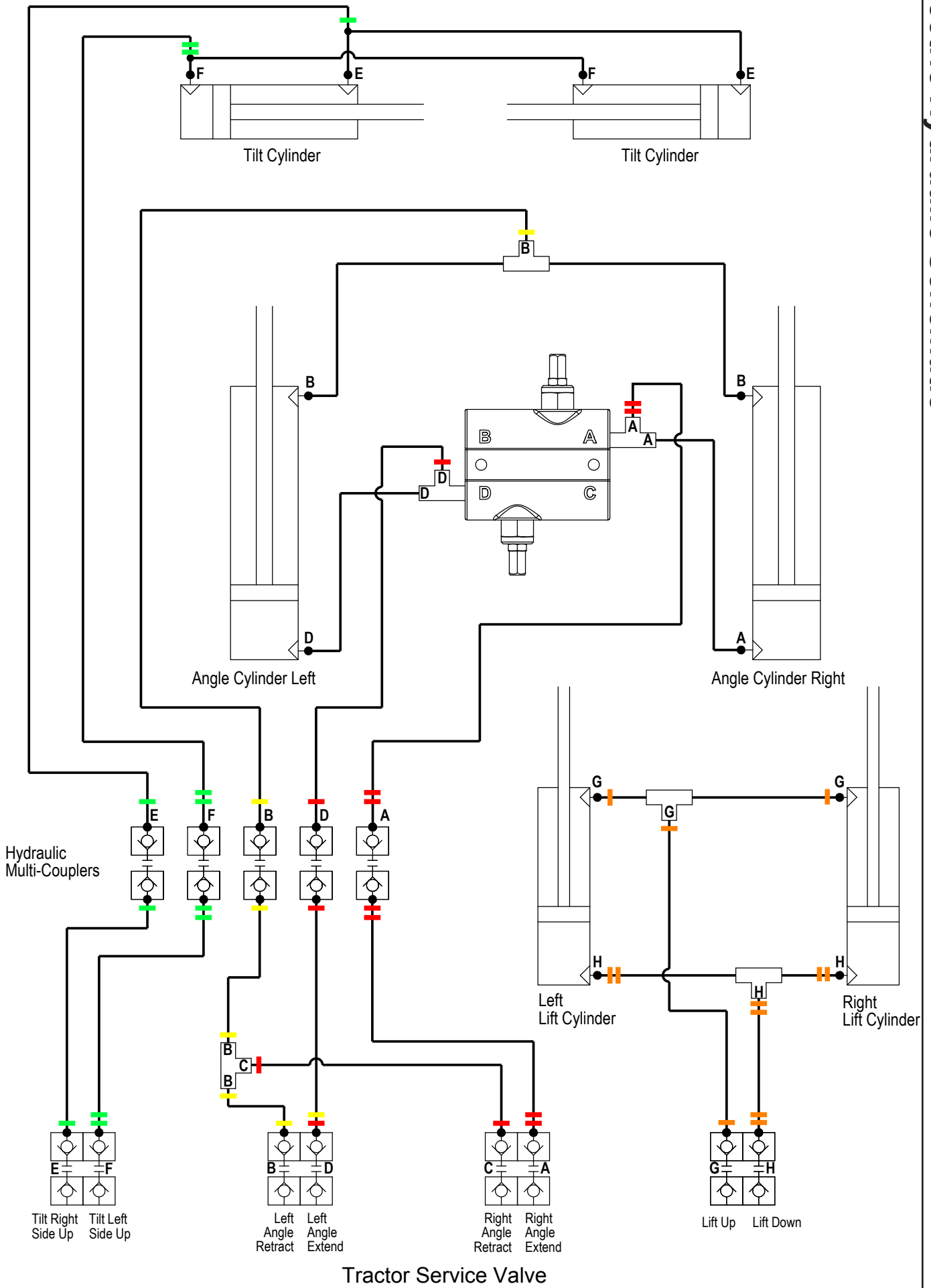

Contact Us

As always, if you have any questions about your Ag Pro Plus HD Dozer or other products made by Grouser, feel free to contact us.

Grouser Products

755 2nd Ave NW - West Fargo, ND 58078

Phone: 1-800-747-6182

Fax: 1-701-282-8131

E-mail: grouser@grouser.com

Website: www.grouser.com

Improvements

Grouser Products Inc. is continually striving to improve its products. We reserve the right to change prices, specification, or equipment at any time without notice. We also reserve the right to make improvements or changes when it becomes practical and possible to do so without incurring any obligation to make changes or additions to the equipment sold previously.

Warranty

Grouser Products warrants to the original purchaser of each item that the product be free from defects in material and workmanship under normal use and service for a period of two years. If such equipment is found to be defective within two years, it is the obligation of Grouser Products under this warranty to repair or replace (exclusive of the cost of labor and transportation), any equipment or parts, in the judgment of Grouser Products to be defective in material or workmanship.

All equipment or parts claimed to be defective in material or workmanship must be made available for inspection at the place of business of a dealer authorized to handle the equipment covered by this warranty, or, upon request by Grouser Products, shipped to the Grouser Products factory in West Fargo, North Dakota. Grouser Products shall have no obligation to bear the cost of labor or transportation in connection with replacement or repair of any such defective parts in the setup process.

This warranty covers only defects in material and workmanship. It does not cover depreciation or damage caused by normal wear, accident, improper assembly, improper adjustments, improper maintenance including lack of proper lubrication, or improper use. Therefore, Grouser Products liability under this warranty shall not be effective or actionable unless the equipment is assembled, maintained and operated in accordance with the operating instructions accompanying the equipment. Grouser Products shall have no liability if the equipment has been altered or reworked without the written authorization of Grouser Products.

Grouser Products' parts, which are furnished under this warranty and properly installed, shall be warranted to the same extent as the original parts under this warranty if, and only if, such parts are found to be defective within the original warranty period covering the original equipment.

