

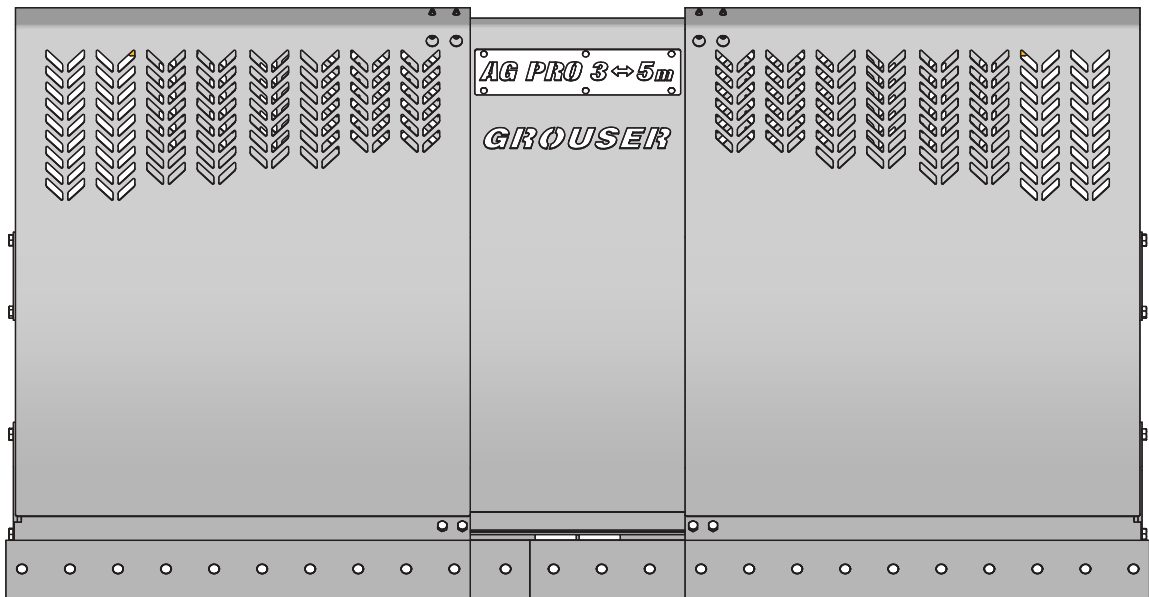

3-5 - Ag Pro NAHT

Owner's Manual & Parts Book



Grouser Products

755 2nd Ave NW - West Fargo, ND 58078

Phone: 1-800-747-6182

Fax: 1-701-282-8131

E-mail: grouser@grouser.com

Website: www.grouser.com

Purchase Date
Serial Number
Model Number
Tractor Model
Dealer

Description	Page
Welcome To The Owner _____	2
Safety Precautions, Torque Specifications & Pre-Installation _____	3
Lift System _____	4
Tractor Side Hydraulics _____	5-8
Initial Startup _____	9
Connecting and Disconnecting _____	10
Skid Shoe Adjustment & Tilt Plate Adjustment _____	11
3-5 Blade Assembly _____	12-13
3-5 NAHT System _____	14-15
NAHT Blade Hydraulics _____	16
Hydraulic Schematics _____	17
Name Plate Assy _____	18
Blade Hydraulic Schematics _____	19
Hydraulic Mult-Coupler Maintenance _____	20-21
Notes _____	22-23
Contact Us, Improvements, & Warranty _____	24

Thank you for your recent purchase of a Grouser Ag Pro 3-5 Dozer. Welcome to the family of satisfied Grouser blade owners. Grouser Products is committed to offering quality products to help professionals in their daily jobs. We are also committed to providing you the highest level of customer satisfaction possible. Again, thank you for your patronage. We look forward to serving you.

This manual contains information concerning the operation, adjustment, safety and maintenance of the Ag Pro 3-5 Dozer. You have purchased a dependable, long lasting piece of equipment. You can expect to receive long lasting performance and long service built into our products with proper care and operation. Please have all operators read and understand this manual carefully. Keep the manual available for reference. If, for any reason, you have questions or comments, we would be happy to hear from you. Call our toll-free number, 800-747-6182, or send us an e-mail at info@grouser.com. You can expect us to respond to your e-mail in a timely manner.

A careful operator is the best operator. Most accidents can be avoided by observing certain precautions. To help prevent accidents, read and take the following precautions before operating this equipment. In addition, please follow all safety and operational instructions of your tractor manufacturer.

The Ag Pro 3-5 Dozer:

1. The Ag Pro 3-5 Dozer should be operated only by those who are responsible and instructed to do so.
2. Read the owner's manual carefully before using this equipment. Lack of operating knowledge can lead to accidents.
3. Keep the Ag Pro 3-5 Dozer maintained in reliable and satisfactory condition to ensure your safety.
4. Make sure the area is clear of people before moving any equipment.
5. Do not modify or permit anyone else to modify or alter the equipment and its components without first consulting Grouser Products.
6. Lower the blade to the ground when not in use.

Servicing the Ag Pro 3-5 Dozer:

1. Read and follow all safety instructions provided by the tractor manufacturer.
2. Always use proper personal safety gear when performing maintenance on equipment.
3. Before servicing, relieve hydraulic pressure, stop engine and fully engage parking brake.
4. Escaping hydraulic fluid under pressure can penetrate skin causing serious injury. If fluid is injected into skin, obtain medical attention immediately.
 - DO NOT use your hand to check for leaks. Use a piece of cardboard or paper to search for leaks.
 - Stop the engine and relieve pressure before connecting or disconnecting lines.
 - Tighten all connections before starting the engine or pressurizing lines.

Storing the Ag Pro 3-5:

1. Thoroughly clean the Ag Pro 3-5 Dozer before storage. Use paint where necessary to prevent rust.
2. Check the Ag Pro 3-5 Dozer for worn or damaged parts. Install new parts as required.
3. Lubricate all pins and joints.

Tighten all bolts to the values listed below unless otherwise noted. Refer to the parts lists for proper length and grade of the bolts.

Size	Torque - Dry (ft-lbs)			
	SAE Grade 5		SAE Grade 8	
	UNC	UNF	UNC	UNF
5/16	17	19	24	27
3/8	30	35	45	50
7/16	50	55	70	80
1/2	75	85	110	120
9/16	110	120	150	170
5/8	150	170	210	240
3/4	260	300	380	420
7/8	430	470	600	670
1	640	720	910	1020

Size	Torque - Dry (ft-lbs)
	Grade 10.9
M18 x 2.50	284
M20 x 2.50	401
M22 x 2.50	547
M24 x 3.00	694

Unstrap and remove the lift frame, hoses, top arms, and any boxes of hardware from the undercarriage. If any components are missing, call Grouser.

Install undercarriage per the tractor specific mounting instructions.

Some assembly of Lift System components is necessary. Follow the steps listed below. See diagram below for the correct hardware and orientation of parts.

1. Remove all pins and fasteners on each side of the undercarriage and set aside for later installation.
2. Position the lift frame between the two plates on both sides of the undercarriage and align to the bottom holes.
3. Insert pins and hardware to attach the lift frame, the base end of the lift cylinders, and the top arms to the undercarriage.
4. Insert pins and hardware to attach the male quick attaches to the lift frame, and to the top arms. Use 2" washers as shims to keep top arm pins tight and in place. Only use as many as needed until pin is tight.
5. Torque all fasteners according to the specifications on Page 3.

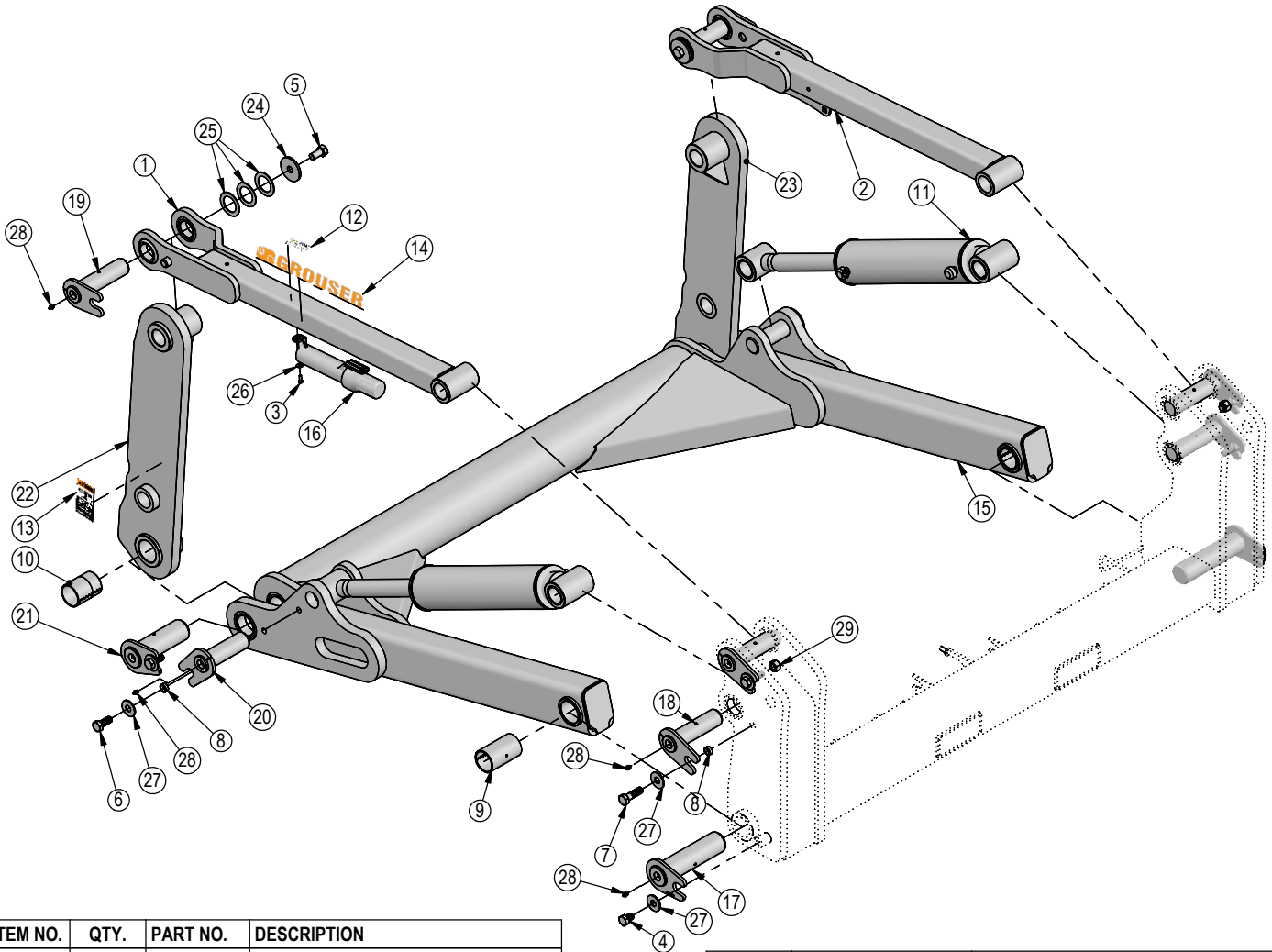

ITEM NO.	QTY.	PART NO.	DESCRIPTION
1	1	11-19975-L	Top Arm Weld
2	1	11-19975-R	Top Arm Weld
3	2	16-20002	1/4" x 3/4" Hex Bolt Gr 5 NC
4	2	16-20214	3/4" x 1" Hex Bolt Gr 5 NC
5	2	16-20216	3/4" x 1-1/2" Hex Bolt Gr 5 NC
6	4	16-20217	3/4" x 1-3/4" Hex Bolt Gr 5 NC
7	4	16-20220	3/4" x 2-1/2" Hex Bolt Gr 5 NC
8	8	19-13515	Spacer, NR Pin
9	2	19-13525	2.75 x 2.50 x 4.75 Spring Bushing
10	2	19-18089	2.75 x 2.50 x 3.75 Spring Bushing
11	2	26-34745	4.5 x 18 Hydraulic Cylinder
12	1	27-40962	Warning Prop 65 Decal
13	2	27-9503	Pinch Decal (Foot)
14	2	27-9504	Grouser Horizontal Decal
15	1	32-18630	Lift Frame, Ag Pro Plus

ITEM NO.	QTY.	PART NO.	DESCRIPTION
16	1	34-14961	Manual Canister Small
17	2	43-14725	Lift Frame / UC Pin
18	4	43-18120	Top Pin Weld
19	2	43-18127	Top Arm Pin Weld
20	2	43-18175	Lift Cyl Pin Weld
21	2	43-18635	Ag Pro Plus QA Pin
22	1	45-18110-L	Male Quick Attach, Ag Pro S
23	1	45-18130-R	Male Quick Attach, Ag Pro S
24	2	57-1530	3" OD X .75 ID X .25" HD Flat Washer
25	6	57-1811	2" Washer
26	2	57-20740	1/4" Flat Washer
27	10	57-20747	3/4" Flat Washer
28	12	58-9369	Straight 1/8" NPT Grease Zerk
29	2	70-20607	3/4" Center Lock Hex Nut Gr 2 NC

Note: Refer to Pages 6-8 for the correct hose lengths and hose location.

Note: All connections are identified by spiral bands. 2 bands are from the base end of a cylinder and 1 band is from the rod end of a cylinder. Orange = Lift, Green = Tilt, Blue = Left Blade Cylinder, and Brown = Right Blade Cylinder.

1. Connect the lift hoses to the lift cylinders.
2. Verify that hoses are not twisted and protected from rubbing on any sharp edges. See Pages 6-8 for proper hose routing.
3. Attach the multi-coupler to the top arm mount and install the 45° fittings.
4. Identify each remaining hose at the front of the undercarriage by the colored bands on the end of the hose and connect the hose to the corresponding 45° fitting on the multi-coupler. Refer to Pages 6-8 for proper hose locations.
5. Hoses were plugged into the rear of the tractor during the undercarriage installation.
6. Continue on Page 9 for initial startup instructions.

HAHT	Hydraulic Angle - Hydraulic Tilt
HANT	Hydraulic Angle - No Tilt
NAHT	No Angle - Hydraulic Tilt
NANT	No Angle - No Tilt

ITEM NO.	PART NO.	NAHT QTY.	DESCRIPTION
1	16-20124	2	1/2" x 1" Hex Bolt Gr.5 NC
2	16-812525	2	8mm x 1.25mm x 25mm Metric Hex Bolt Gr 10.9
3	18-19995-L	1	Multi-Coupler Mount
4	25-19868	1	Multi-Coupling Plate - 2 Port - Fixed
5	25-19870	2	Multi-Coupling Plate - Male Coupler
6	25-19871	1	Multi-Coupling Plate - 2 Port - Cap
7	25-40407	2	Multi-Coupling Plate - Snap Ring
8	25-34342	4	Tappet Quick Coupler Male - Poppet Style
9	25-3453	2	Pioneer Dust Cap Tilt (Green)
10	25-3457	2	Pioneer Dust Cap Lift (Orange)
11	31-11699-10-10	2	JIC Union
12	31-15199-8-8	2	JIC Union Elbow 90°
13	31-34032	2	Bulkhead Run Tee JIC
14A,B	31-34051	2	Straight Thread Elbow 90° JIC x O-Ring
14C	31-6802-12-10	2	Straight Thread Elbow 45° JIC x O-Ring
15A,B	31-34059	2	Straight Thread Elbow 90° JIC x O-Ring
15C	31-6802-8-10	2	Straight Thread Elbow 45° JIC x O-Ring
16	31-34150	2	Straight Thread Elbow 45° JIC x O-Ring
17	31-6400-10-08	4	Straight JIC x O-Ring
18	34-12932	2	Cylinder Saddle
19	34-16578	2	Hose Clamp (worm drive - 4.5)
20	34-18888-GR	9	-12 Green - Spiral Band
21	34-19494-OR	15	-16 Orange - Spiral Band
22	35-12636-0535	2	53.5" x 5/8" -10JIC/-12JIC Hose W/Cordura
23	35-12636-0670	2	67" x 5/8" -10JIC/-12JIC Hose W/Cordura
24A,C	35-12329-3000	2	300" (25") x 3/4" -12JIC/-12JIC Hose w/ Cordura
24B	35-18984-3200	2	320" (26.67") x 3/4" -12JIC/-12JIC Hose w/ 180" Cordura
25A,C	35-30183	2	293" (24.42") x 1/2" -8JIC/-8JIC Hose w/165" Cordura
25B	35-18953-3200	2	320" (24.42") x 1/2" -8JIC/-8JIC Hose w/180" Cordura
26	35-18240	2	Lift Cylinder Steel Line
27	35-31136	2	81" x 1/2" -8JIC/-8JIC Hose w/Cordura
28	57-20740	2	1/4" Flat Washer
29	57-20744	2	1/2" Washer
30	70-20809	2	1-1/16" Hex Jam Nut

***Parts Not Shown**

Hoses Not Drawn to Scale

Item A for CNH, JD 9R, JD 9030

Item B for Versatile, Challenger MT900 and JD 9RX

Item C for Claas Xerion

Every hydraulic function from the front to the back of the system is designated by a \circ and a letter and can also be referenced on the Hydraulic Schematics on Page 17 & 19.

View of Left Side Hoses
From The Front

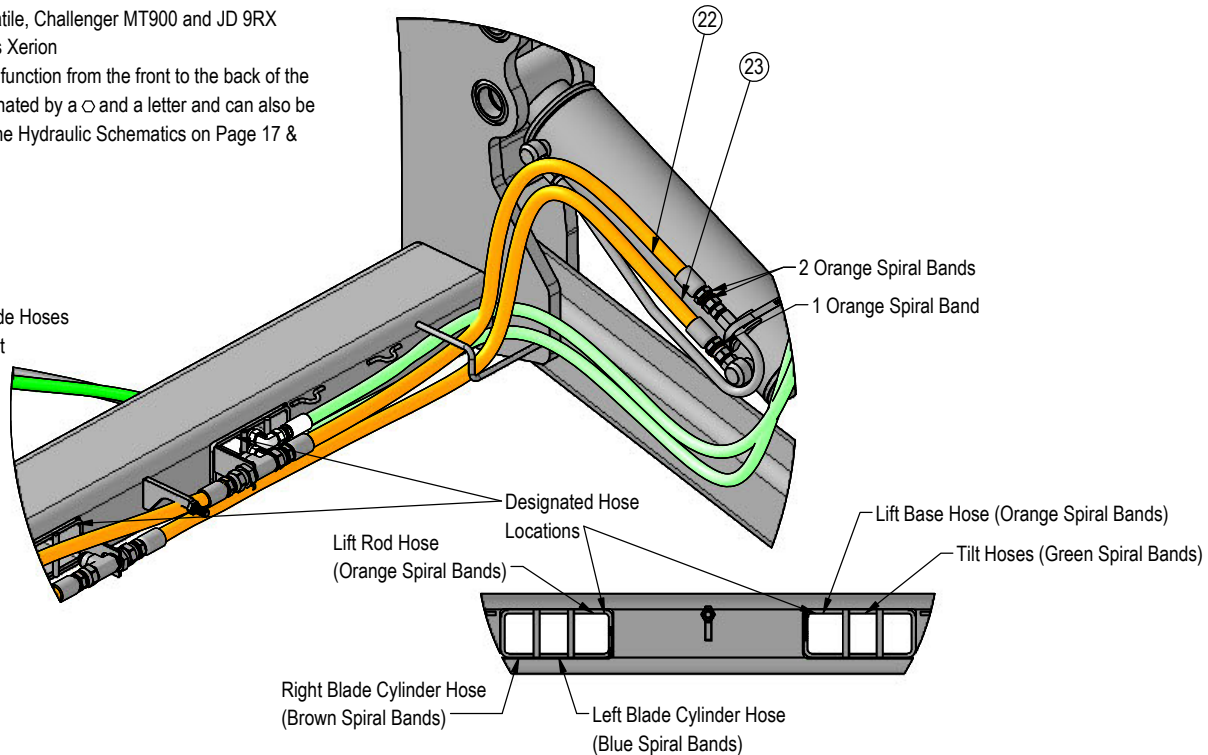

See Detail A for correct hose locations

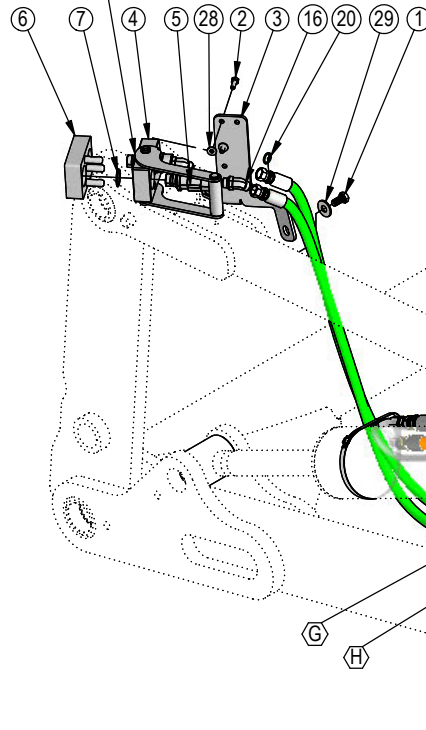

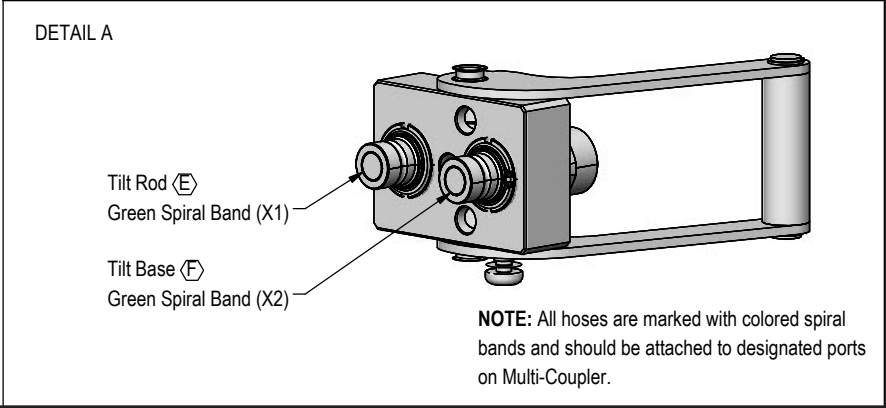
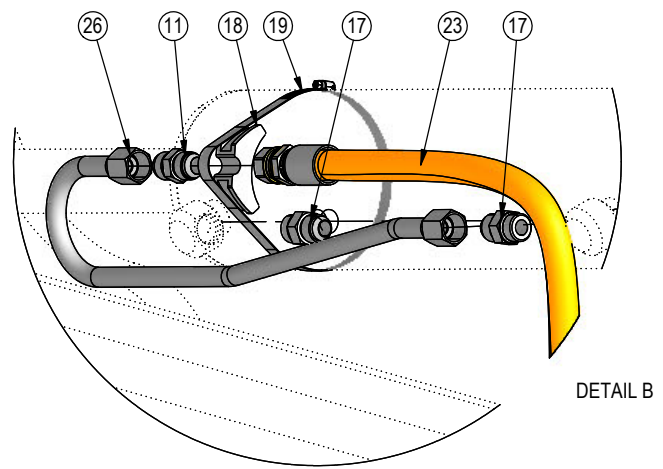
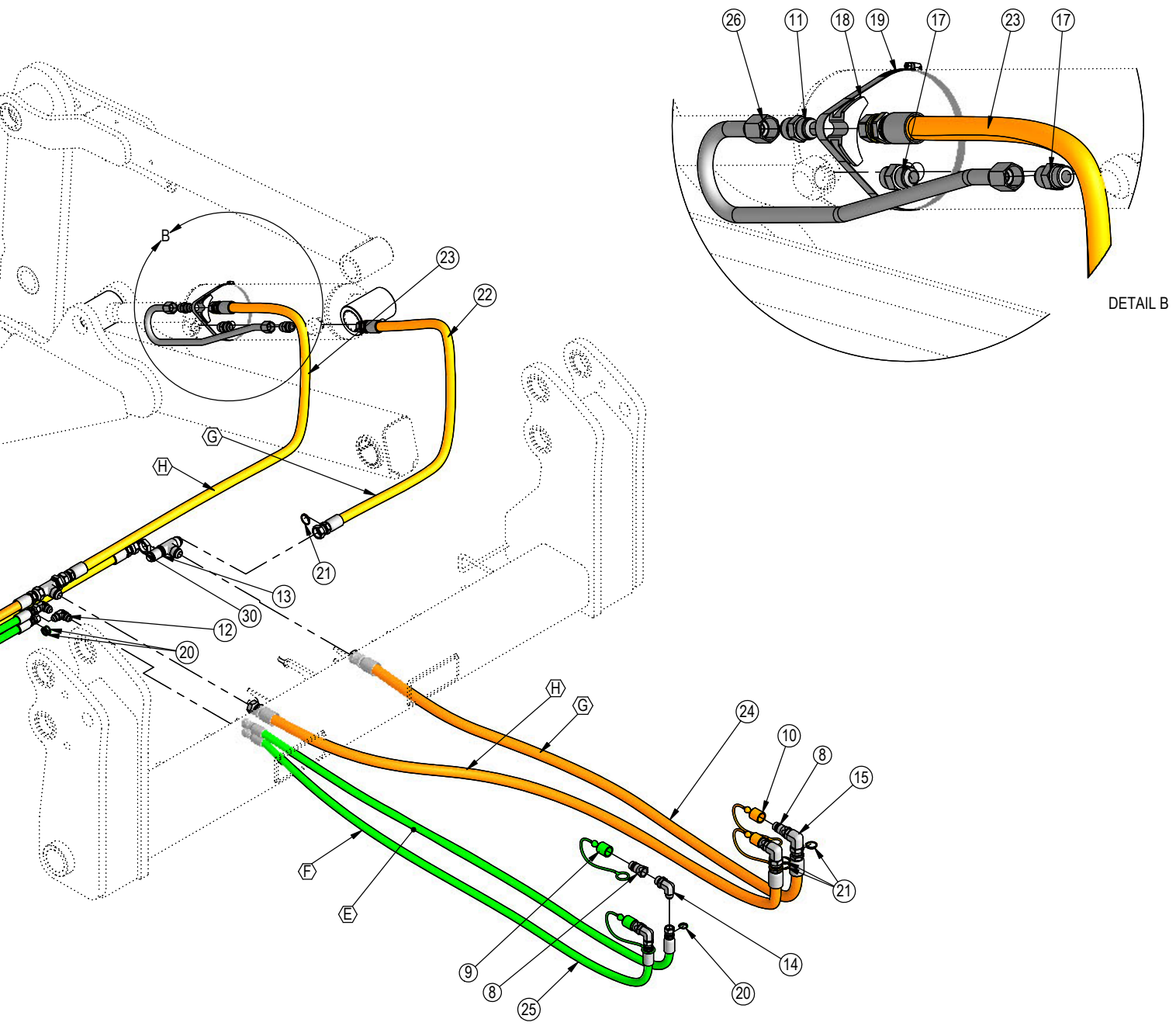

ITEM NO.	SINGLE CONTROL QTY.	DUAL CONTROL QTY.	PART NO.	DESCRIPTION
1	2	2	16-20124	1/2" x 1" Hex Bolt Gr.5 NC
2	2	2	16-812525	8mm x 1.25mm x 25mm Metric Hex Bolt Gr 10.9
3	1	1	18-19995-R	Multi-Coupler Mount
4	-	1	25-19864	Multi-Coupling Plate - 4 Port Fixed
5	-	1	25-19867	Multi-Coupling Plate - 4 Port - Cap
6	2	-	25-19868	Multi-Coupling Plate - 2 Port - Fixed
7	2	-	25-19871	Multi-Coupling Plate - 2 Port - Cap
8	2	4	25-19870	Multi-Coupling Plate - Male Coupler
9	2	4	25-40407	Multi-Coupling Plate - Snap Ring
10	2	4	25-34342	Tappet Quick Coupler Male - Poppet Style
11	-	2	25-3403	Pioneer Dust Cap Slider (Blue) (Left Cylinder)
12	2	2	25-3405	Pioneer Dust Cap Slider (Brown) (Right Cylinder)
13	2	4	31-15199-8-8	JIC Union Elbow 90°
14	2	4	31-34051	Straight Thread Elbow 90° JIC x O-Ring
15	2	4	31-34150	Straight Thread Elbow 45° JIC x O-Ring
16	9	9	34-18888-BL	-12 Blue - Spiral Band
17	-	9	34-18888-BR	-12 Brown - Spiral Band
18	2	4	35-30183	293" (24.42") x 1/2" -8JIC/-8JIC Hose
19	-	2	35-31135	78" x 1/2" -8JIC/-8JIC Hose W/Cordura
20	2	2	35-31136	81" x 1/2" -8JIC/-8JIC Hose W/Cordura
21	2	2	57-20741	5/16" Flat Washer
22	2	2	57-20744	1/2" Washer

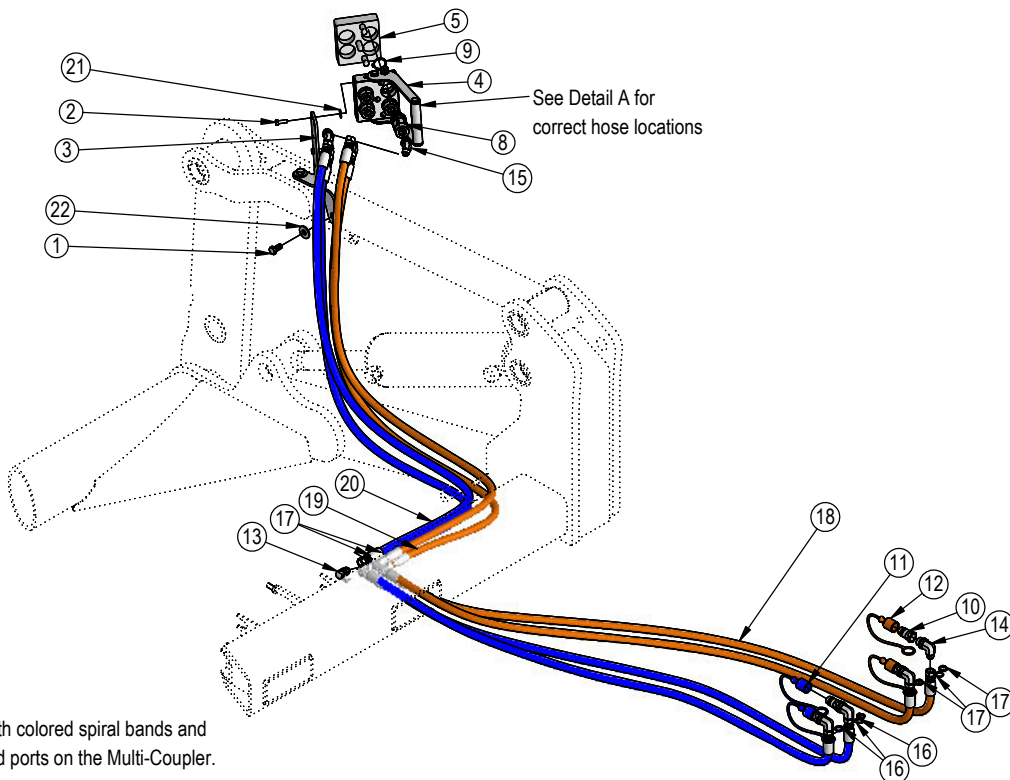

NOTE: All hoses are marked with colored spiral bands and should be attached to designated ports on the Multi-Coupler.

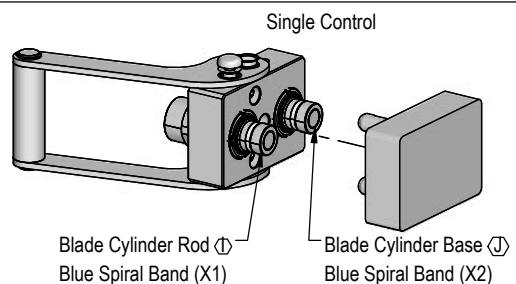
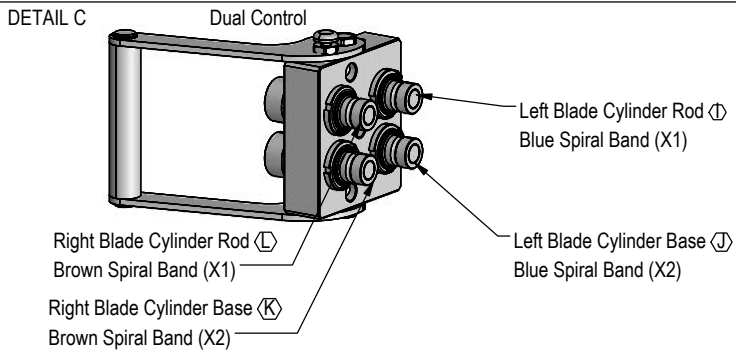

Prior to operating the blade system, all air must be purged from the hydraulic system. Follow the steps below for each function on your blade.

Lift Function:

1. With the lift frame down and blocked, loosen the fittings on both ends of the lift cylinders.
2. Actuate the raise function to supply oil to the rod end of the cylinders.
3. When oil starts to flow from the fittings, stop oil flow, and tighten the fitting on the rod end of the lift cylinders.
4. Continue to flow oil until the system is fully raised and then block the lift frame.
5. Actuate the function in the opposite direction to supply oil to the base end of the lift cylinders.
6. When all air is removed from the lift system, stop oil flow and tighten the fittings on the base end of the lift cylinders.
7. Raise lift system and remove blocks. Cycle up and down 5 more times.
8. Check tractor oil level and fill if necessary.
9. Continue with connecting the blade on Page 10.

Tilt Function:

1. Use a lift or jack to tilt the blade system until the left side is fully up, loosen the fittings on the rod and base end of both tilt cylinders.
2. Actuate the tilt function to extend the right tilt cylinder and supply oil to the base end of the right cylinder and to the rod end of the left cylinder.
3. When oil starts to flow from the fittings, stop oil flow, and tighten the fitting on the base end of the right cylinder and rod end of the left cylinder.
4. Remove the lift or jack.
5. Continue to actuate the tilt function until oil flows out of the remaining open ports.
6. Actuate the tilt function in the opposite direction.
7. When all air is removed from the tilt system, stop oil flow, and tighten the remaining fittings on the cylinders.
8. Cycle both cylinders in and out 5 more times.
9. Check tractor oil level and fill if necessary.

Blade Width Function:

1. Loosen the fittings on the rod and base end of the right cylinder.
2. Actuate the blade width function to extend the right cylinder and supply oil to the base end of the right cylinder.
3. When oil starts to flow from the fittings, stop oil flow, and tighten the fitting on the base end of the right cylinder.
4. Fully extend the right cylinder.
5. Actuate the function in the opposite direction.
6. When oil starts to flow from the rod end fitting, stop oil flow, and tighten the remaining fittings on the cylinders.
7. Continue to actuate the cylinder until cylinder is fully retracted.
8. Cycle the right cylinder in and out 5 more times.
9. Repeat Steps 1-8 for the left cylinder
10. Check tractor oil level and fill if necessary.

Run the blade through all the functions. If any function does not operate correctly, refer to corresponding section above and re-bleed. If problem still persists, call Grouser Products.

To Connect:

Note: If necessary, use a spotter to help center the blade on the lift system.

1. If necessary, lift the locking latch and push the quick attach lock handle on the left side of the lift system to open the quick attach system. Refer to Page #15 for further clarification on the quick attach system.
2. Drive the tractor forward slowly until the top edge of the male quick attach is under the top hook of the female quick attach on the blade assembly.
3. Raise the lift system until the male quick attach engages the female hook. If both sides don't fully engage, reposition. Continue to raise the lift system until the blade is off the ground and the female quick attaches are against the front of the male quick attaches.
4. Shut off the tractor engine and set the parking brake.
5. Pull the quick attach lock handle to engage the quick attach pins and lift the locking latch to lock the handle in place.
6. Clean and connect hydraulic multi-coupler on the top arm. Refer to Pages 20-21 for cleaning and connecting information.
7. If initial startup, refer to Page 9 before operating any function of the blade.

To Disconnect:

1. Lower the blade until the cutting edge is off the ground a few inches.
2. Shut off the tractor engine and set the parking brake.
3. Unhook the multi-coupler on the top arm.
4. Remove the multi-coupler covers from the parking stations on the blade assembly and install on the multi-couplers on the top arms.
5. Plug the blade side multi-couplers into the parking station.
6. Lift the locking latch and push the quick attach lock handle to disengage the quick attach pins.
7. Start tractor, disengage the parking brake, and lower the blade until cutting edge is on the ground.
8. Continue to slowly lower the lift system to disengage the blade.
9. Slowly back away from the blade. When lift system is clear from the blade, raise the lift system.
10. Shut off the tractor engine and set the parking brake.

Skid Shoe Adjustment:

1. Remove the handle from the ratchet keeper by pulling the hitch clip pin and insert it into the handle receiver on the ratchet jack.
2. Loosen the locking nut on the ratchet jack.
3. Hold the body of the ratchet jack and rotate the ratchet jack handle to raise or lower the skid shoes.
4. If the skid shoe is not moving in the proper direction, flip the forward/reverse lever on the handle (see Figure 2). Rotate the ratchet jack handle again to move the skid shoe in the desired direction.
5. After the skid shoe is adjusted, rotate the ratchet jack handle until it rests against the ratchet keeper. Return the removable handle to the ratchet keeper ensuring that the ratchet jack handle is captured by the removable handle and the ratchet keeper. Secure the handle to the ratchet keeper with the hitch clip pin.
6. Tighten the locking nut against the ratchet jack body to keep it from moving.
7. When skid shoes are worn up to the bolt heads, replace skid shoes.

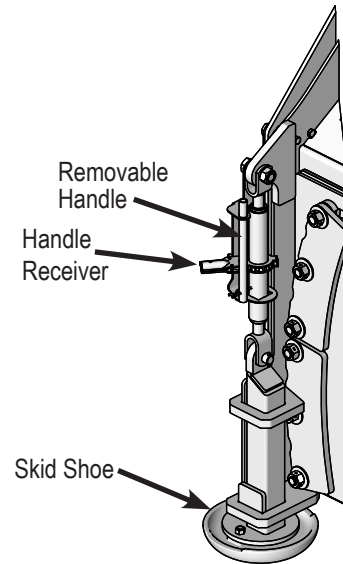

Figure 1

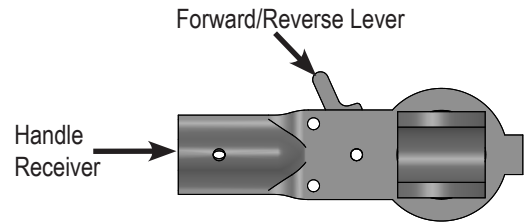

Figure 2

Preferred Method:

1. The preferred blade position for adjusting the tilt plates is laying face down on blocks.
2. Remove the 6 nuts from the right tilt plates.
3. Remove skid mount to obtain better access to the bottom nuts.
4. Add or remove washers as needed to adjust tilt-way clearance to 1/16" - 1/8".
5. Reinstall the nuts in the right tilt plates.
6. Follow Steps #2-5 for the left tilt plates.
7. Once the tilt-way clearance is set, torque bolts to 640 ft-lbs.

Non-Preferred Method:

Note: Do not remove all of the bolts at the same time if the blade is not laying face down.

1. The non-preferred blade position for adjusting the tilt plates is the blade in the upright position.
2. Remove the skid shoe mounts to obtain better access to bottom tilt plate nuts.
3. Remove the 3 nuts from the top right tilt plate and the bottom left tilt plate..
4. Add or remove washers as needed to adjust tilt-way clearance to 1/16" - 1/8".
5. Reinstall the nuts in the top right tilt plate and the bottom left tilt plate.
6. Follow Steps #2-5 for the bottom right tilt plate and the top left tilt plate.
7. Once the tilt-way clearance is set, torque bolts to 640 ft-lbs.

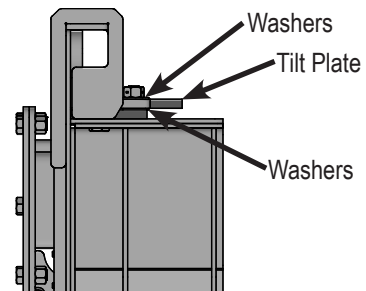

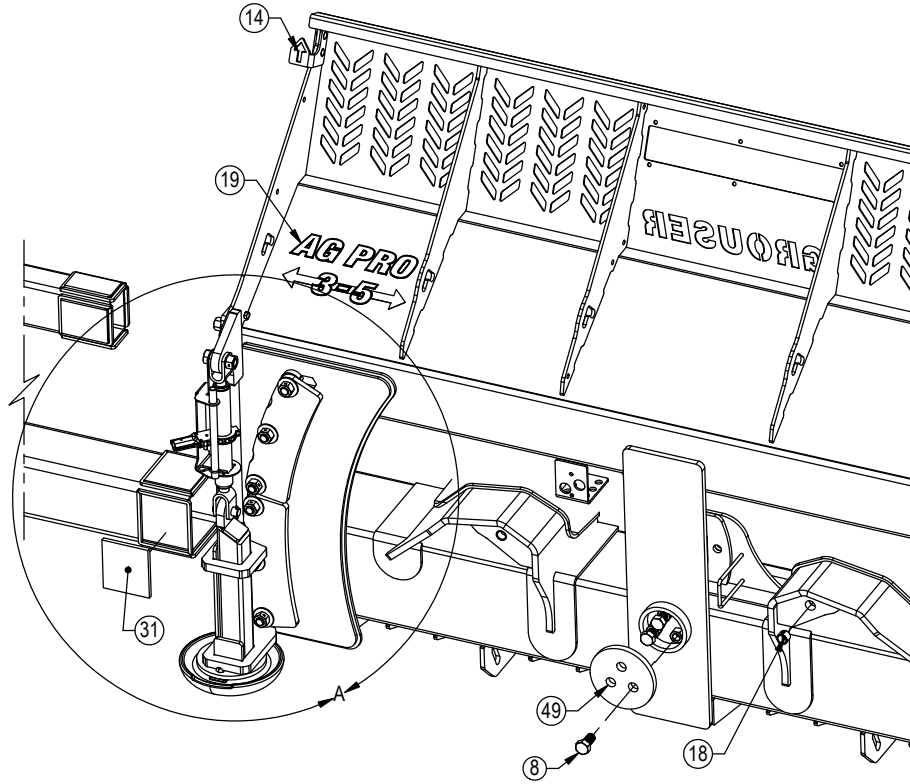
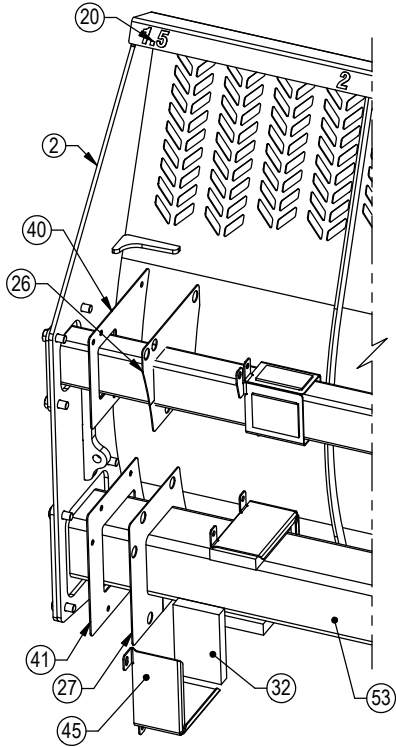

* Part Not Shown

ITEM NO.	QTY.	PART NO.	DESCRIPTION
1	1	15-18735R2	XAXT Blade Weld
2	1	15-18760-L	3-5 Slider End Weld - Left
3	1	15-18760-R	3-5 Slider End Weld - Right
4	12	16-16305	3/8" x 1.25" Flanged Elevator Bolt
5	2	16-18945	1" x 3" Hex Bolt Gr 5 NC - Short Thread
6	18	16-20538	7/8" x 2" Hex Bolt Gr 8 NC
7	4	16-20517	3/4" X 4-1/2" Hex Bolt Gr. 8 NC
8	3	16-20558	1" X 2" Hex Bolt Gr. 8 NC
9	4	16-20561	1" x 2-3/4" Hex Bolt Gr.8 NC
10	8	16-20563	1" x 3-1/4" Hex Bolt Gr.8 NC
11	4	16-21064	3/8" x 1" Carriage Bolt Gr 5 NC
12	4	16-21666	5/8" x 1-3/4" Plow Bolt Gr 5 NC
13	38	16-21748	3/4" X 2" Plow Bolt Gr 8 NC
14	1	18-16304-L	Bracket, Left Location
15	1	18-16304-R	Bracket, Right Location
16	1	18-18498-L R2	Ratchet Keeper - Left
17*	1	18-18498-R R2	Ratchet Keeper - Right
18	2	19-7774	1" x 1" Spring Bushing
19	1	27-18936	Ag Pro 3-5 Decal
20	1	27-18937-L	Ag Pro 3-5 Width Decal - Left
21	1	27-18937-R	Ag Pro 3-5 Width Decal - Right
22	1	29-11118-4	4' - 3/4" x 8" Cutting Edge
23*	1	29-11118-5	5' - 3/4" x 8" Cutting Edge
24	2	29-18777	58" - 3/4 x 8 Cutting Edge
25	6	34-16158	Bearing, 2.625 x 6.00 W/Holes
26	2	34-16419	Top Seal
27	1	34-16420	8" Tube Seal
28	1	34-16421	10" Tube Seal
29	8	34-16425	Top Narrow UHMW
30	8	34-16426	Top Wide UHMW
31	4	34-16427	8" Inner UHMW
32	4	34-16428	8" Outer UHMW
33	8	34-16429	10" UHMW
34	2	34-17565	Skid Shoe Ratchet Jack (S01054100)

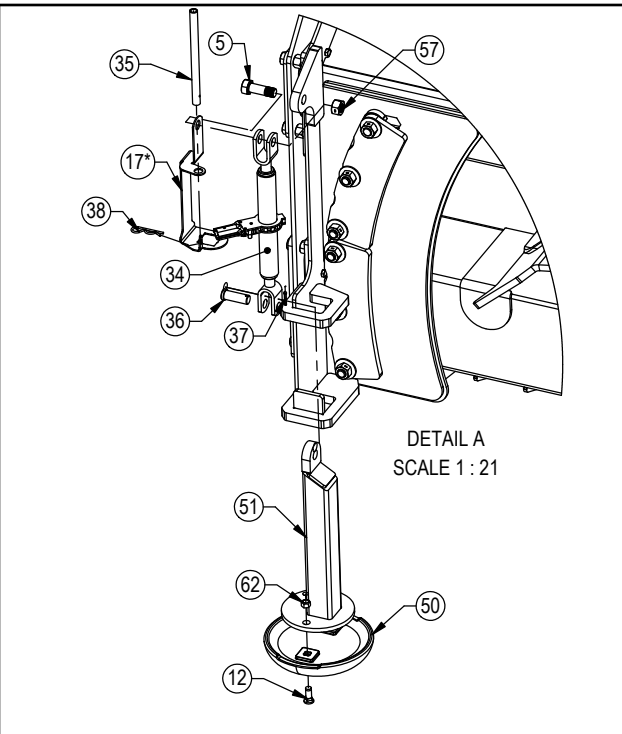

ITEM NO.	QTY.	PART NO.	DESCRIPTION
35	2	34-17567	Handle, Ratchet Jack
36	2	43-18463	1" x 2.75" Pin (S57190400)
37	2	43-18943	3/16" x 1-1/2" Cotter Pin
38	2	43-7767	Cylinder Pin Clip
39	1	44-16401 R1	Plate, Top Cover Right
40	1	44-16402 R1	Plate, Top Cover Left
41	1	44-16403	Plate, 8" Cover
42	1	44-16404 R1	Plate, 10" Cover
43	2	44-16417 R1	Plate, Slider
44	4	44-16422	Top Outer Retainer
45	2	44-16423 R1	8" Outer Retainer
46	2	44-16424	10" Outer Retainer
47	2	44-16525	Standoff
48	12	44-16977 R1	Plate, Slider Standoff Shim
49	1	44-3749R1	Backdrag Brace Plate
50	2	50-15458	12" Round Mushroom Skid Shoe
51	2	50-18775	Slider Skid Shoe Weld
52	4	52-18299R1	Tilt Plate
53	1	53-18768R1	8 x 8 Tube Weld, 3-5 Slider
54	1	53-18770R2	10 x 10 Tube Weld, 3-5 Slider
55	2	53-18772R1	4 x 6 Tube Weld, 3-5 Slider
56	24	57-20749	1" Flat Washer
57	2	70-18999	1" Hex Center Lock Nut Gr 2 NC - YZ
58	24	70-20584	1/2" Hex Nut Gr 5 NC
59	18	70-20598	7/8" Hex Nut Gr 8 NC
60	12	70-20609	1" Hex Center Lock Nut Gr.2 NC
61	16	70-20622	3/8" Flange Hex Nut Gr 5 NC
62	4	70-20646	5/8" Hex Top Lock Nut Gr 5 NC
63	38	70-20647	3/4" Hex Top Lock Nut Gr 5 NC
64	20	70-20804	1/2" Hex Jam Nut

Use Shims (#48) to achieve 0.06"-0.08" Tolerance

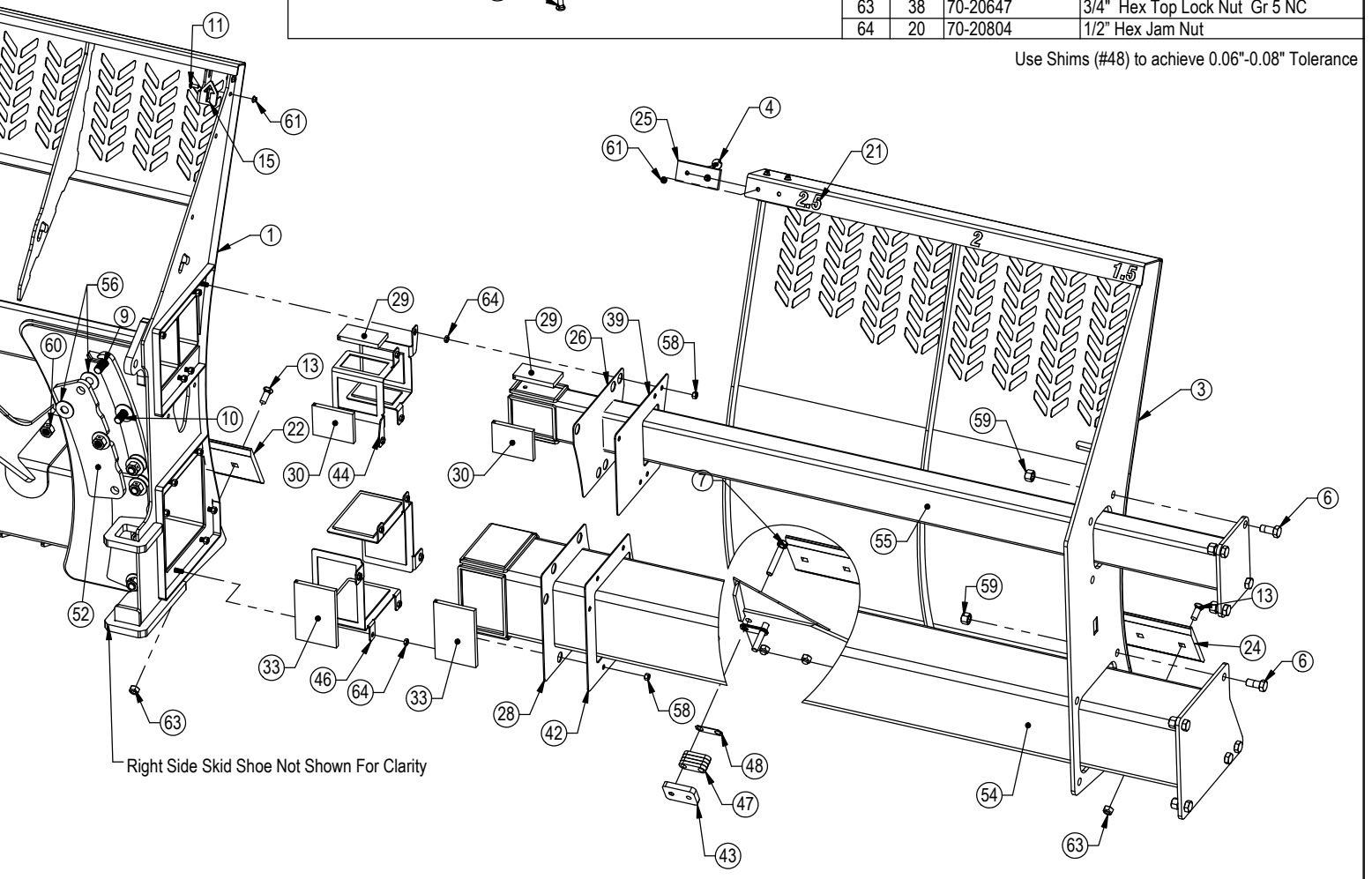

Right Side Skid Shoe Not Shown For Clarity

ITEM NO.	QTY.	PART NO.	DESCRIPTION
1	1	11-40866	Bell Crank
2	1	16-20011	1/4" x 2-3/4" Hex Bolt Gr 5 NC
3	5	16-20036	5/16" x 1-1/2" Hex Bolt Gr 5 NC
4	2	16-20130	1/2" x 2-1/2" Hex Bolt Gr 5 NC
5	5	16-20560	1" x 2-1/2" Hex Bolt Gr 8 NC
6	2	16-20561	1" x 2-3/4" Hex Bolt Gr.8 NC
7	1	16-20562	1" x 3" Hex Bolt Gr 8 NC
8	2	16-21065	3/8" x 1-1/4" Carriage Bolt Gr 5 NC
9	4	16-21126	1/2" x 1-1/2" Carriage Bolt Gr 5 NC
10	4	16-35C612	3/8" x 3/4" Flange Bolt
11	2	16-812525	8mm x 1.25mm x 25mm Metric Hex Bolt Gr 10.9
12	1	18-40589-L	Multi-Coupler Bracket
13	1	18-42046	Bottom Bracket
14	1	18-42048	Top Bracket
15	4	19-13577	NR Pin Spacer Clevis End
16	2	19-40440	.378" ID x .503" OD x .375" Spacer
17	2	19-7774	1" x 1" Spring Bushing
18	1	25-19657	Multi-Coupling Plate - 2 Port Parking Station
19	2	25-19865	Multi-Coupling Plate - Female Coupler
20	1	25-19869	Multi-Coupling Plate - 2 Port - Mobile
21	2	25-40407	Multi-Coupling Plate - Snap Ring

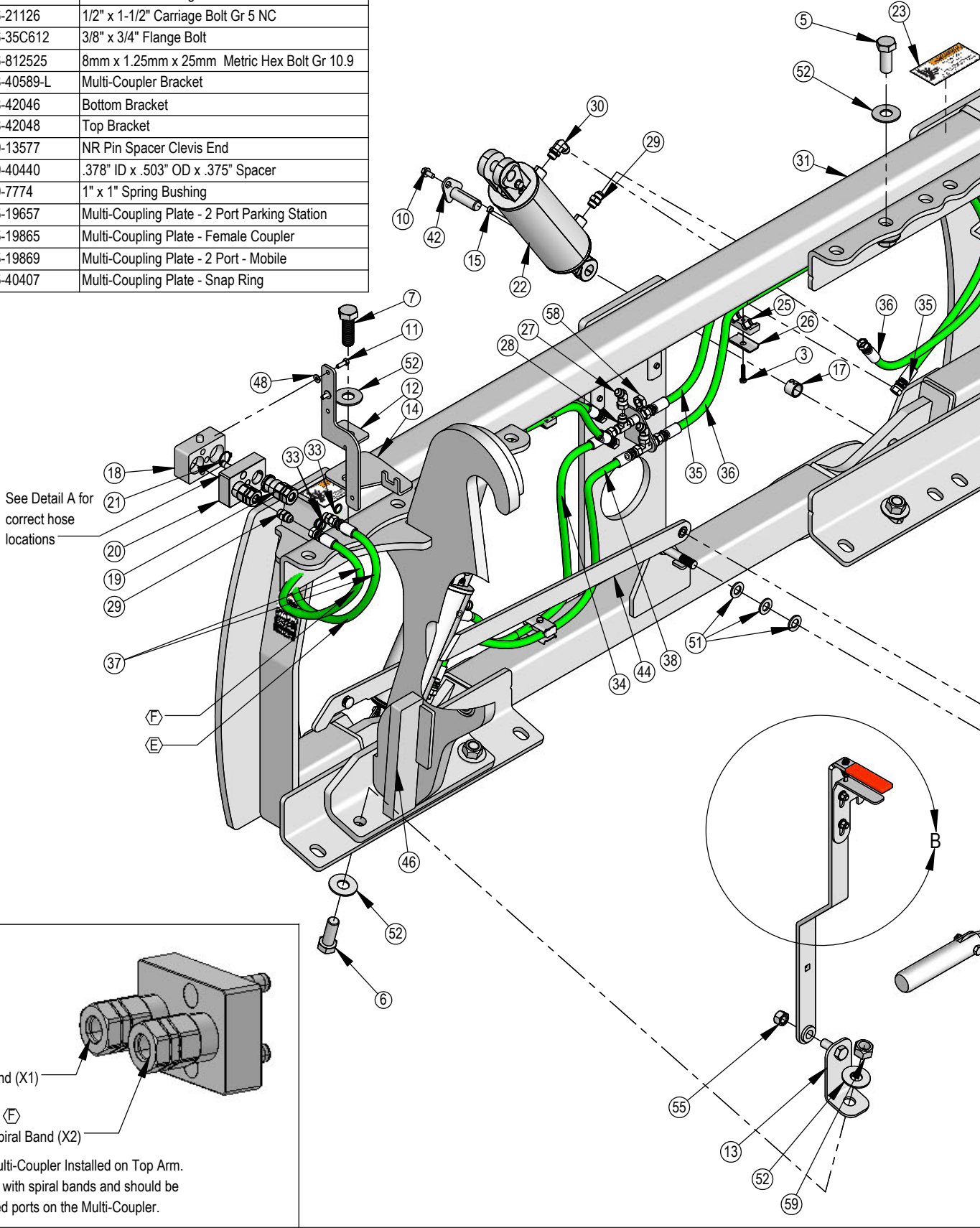

Detail A

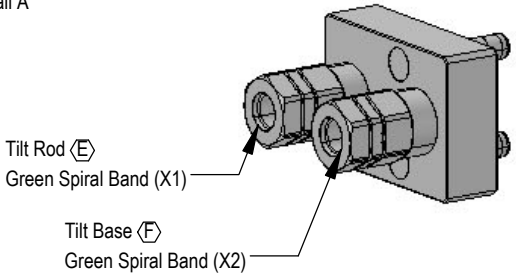

Note: View is from Multi-Coupler Installed on Top Arm.
 All hoses are marked with spiral bands and should be attached to designated ports on the Multi-Coupler.

ITEM NO.	QTY.	PART NO.	DESCRIPTION
22	2	26-34747	4 x 8 Hydraulic Cylinder
23	2	27-2409	Pinch Decal (Hand)
24	2	27-9503	Pinch Decal (Foot)
25	5	3074	Hose Hold Down Clamp
26	5	3075	Hose Hold Down Clamp Plate
27	2	31-11492-8-8	Male JIC x Female JIC Swivel Nut Elbow 45°
28	2	31-34030	Bulkhead Run Tee JIC
29	4	31-34040	Straight JIC x O-Ring
30	2	31-34050	Straight Thread Elbow 90° JIC x O-Ring
31	1	32-18780	Tilt Frame Weld
32	1	34-17799	Latch Spring
33	12	34-18888-GR	-12 Green - Spiral Band
34	1	35-30021	36" x 3/8" -8JIC/-8JIC Hose
35	1	35-30033	72" x 3/8" -8JIC/-8JIC Hose
36	1	35-30036	80" x 3/8" -8JIC/-8JIC Hose
37	2	35-30035	78" x 3/8" -8JIC/-8JIC Hose
38	1	35-30079	40" x 3/8" -8JIC/-8JIC Hose
39	1	39-14663	Latch
40	1	39-3072	Rubber Handle
41	1	39-42050	Handle Weld
42	4	43-13580	Pin Weld
43	2	43-18486	AG Pro SS QA Lock Pin
44	1	44-42049	Link, Handle to Bell Crank
45	4	44-8490	Spacer
46	1	45-40870-L	SS Bolt in Quick Attach - Left
47	1	45-40870-R	SS Bolt in Quick Attach - Right
48	2	57-20740	1/4" Flat Washer
49	2	57-20742	3/8" Flat Washer
50	4	57-20744	1/2" Washer
51	3	57-20757	3/4" Flat Washer - 1-1/2" OD
52	16	57-20819	1" Flat Washer Heavy Duty Gr 8
53	4	57-40408	3/8" Flat Nylon Washer
54	6	70-20604	1/2" Hex Center Lock Nut Gr. 2
55	2	70-20607	3/4" Center Lock Hex Nut Gr 2 NC
56	1	70-20610	1/4" Nyloc Hex Nut Gr 5 NC
57	2	70-20612	3/8" Nyloc Hex Nut Gr 5 NC
58	2	70-20807	3/4" Hex Jam Nut NF
59	8	70-20999	1" Hex Top Lock Nut Gr 8 NC
60	2	75-40869	Link, Bell Crank To Pin

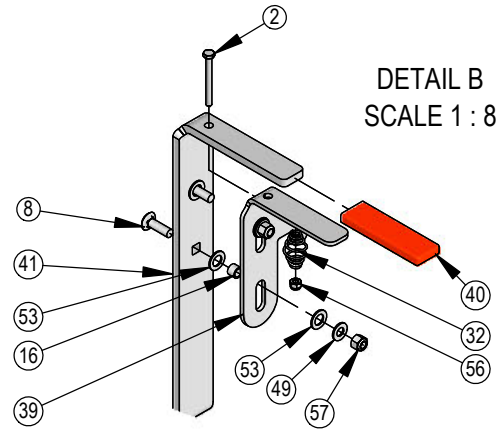
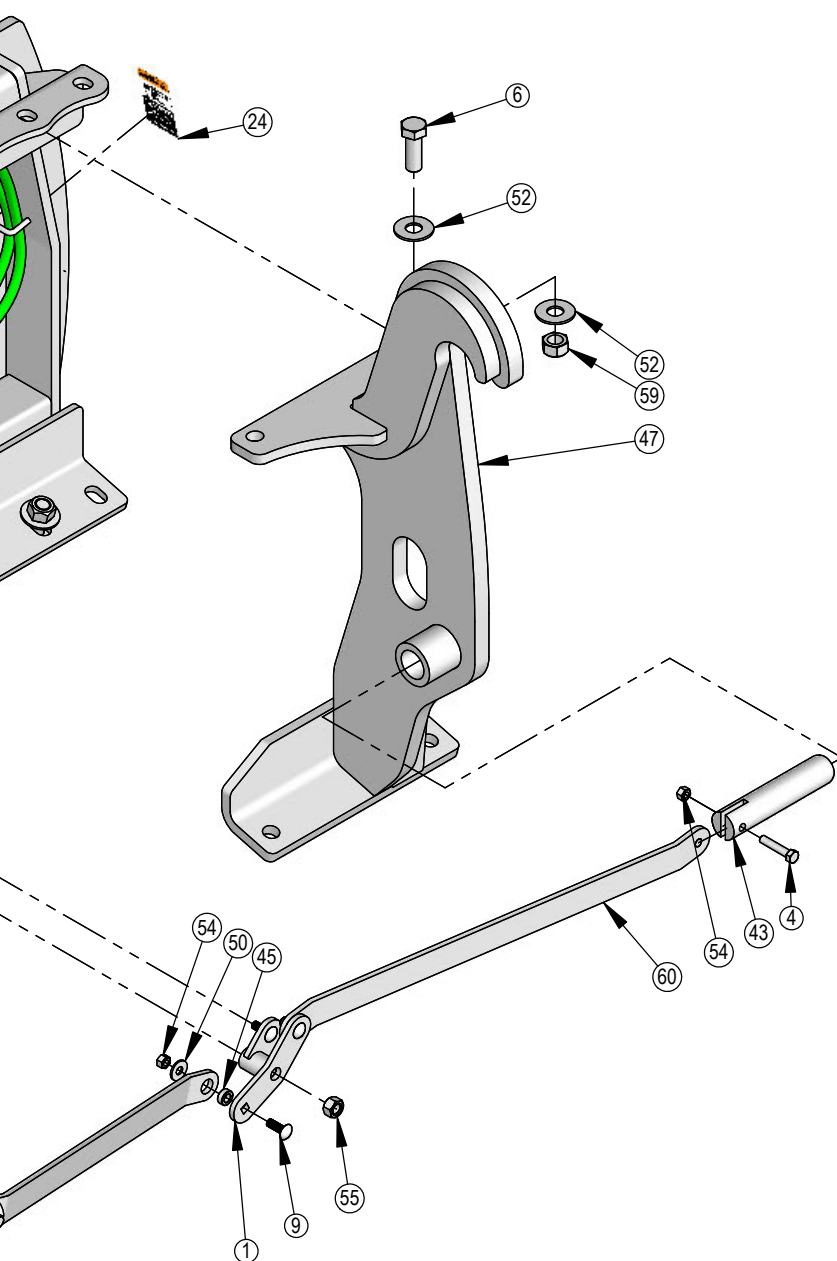

DWG. NO.: 41668

ITEM NO.	QTY.	PART NO.	DESCRIPTION
1	1	16-20043	5/16" x 3-1/4" Hex Bolt Gr. 5 NC
2	2	16-20126	1/2" x 1-1/2" Hex Bolt Gr. 5 NC
3	2	16-812525	8mm x 1.25mm x 25mm Metric Hex Bolt Gr 10.9
4	2	18-19311-02-P-062	Hose Clamp
5	2	18-19312-02	Twin Cover Plate
6	1	18-40589-R	Multi-Coupler Bracket
7	1	25-18956	Multi-Coupling Plate - 4 Port Parking Station
8	1	25-19866	Multi-Coupling Plate - 4 Port Mobile
9	2	26-34741	3 x 48 Hydraulic Cylinder
10	4	31-34040	Straight JIC x O-Ring
11	4	31-34050	Straight Thread Elbow 90° JIC x O-Ring
12	2	34-17585R1	Cylinder Strap

ITEM NO.	QTY.	PART NO.	DESCRIPTION
13	1	35-11686-0650	65" x 3/8" -8JIC x -8JIC Hose
14	2	35-11686-0850	85" x 3/8" -8JIC x -8JIC Hose
15	1	35-11686-1310	131" x 3/8" -8JIC x -8JIC Hose
16	4	43-16306	Cylinder Pin w/ Cotter Pins
17	4	43-18943	3/16" x 1-1/2" Cotter Pin
18	4	43-7767	Cylinder Pin Clip
19	2	57-20740	1/4" Flat Washer
20	4	57-20744	1/2" Flat Washer
21	1	70-20611	5/16" Nyloc Hex Nut Gr. 5
22	2	70-20604	1/2" Hex Center Lock Nut Gr. 2

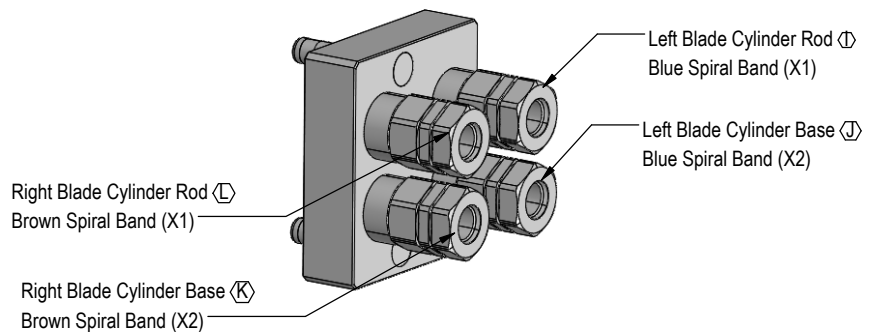
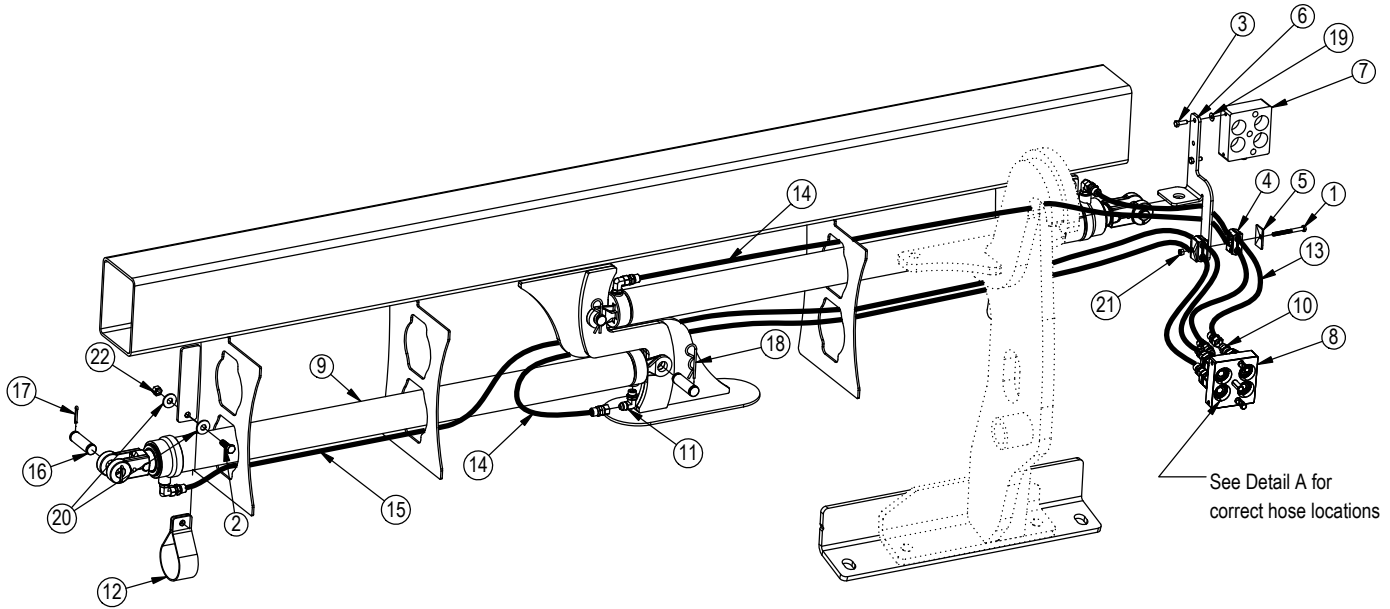

Note: View is from Multi-Coupler installed on Top Arm. All hoses are marked with colored spiral bands and should be attached to designated ports on the Multi-Coupler.

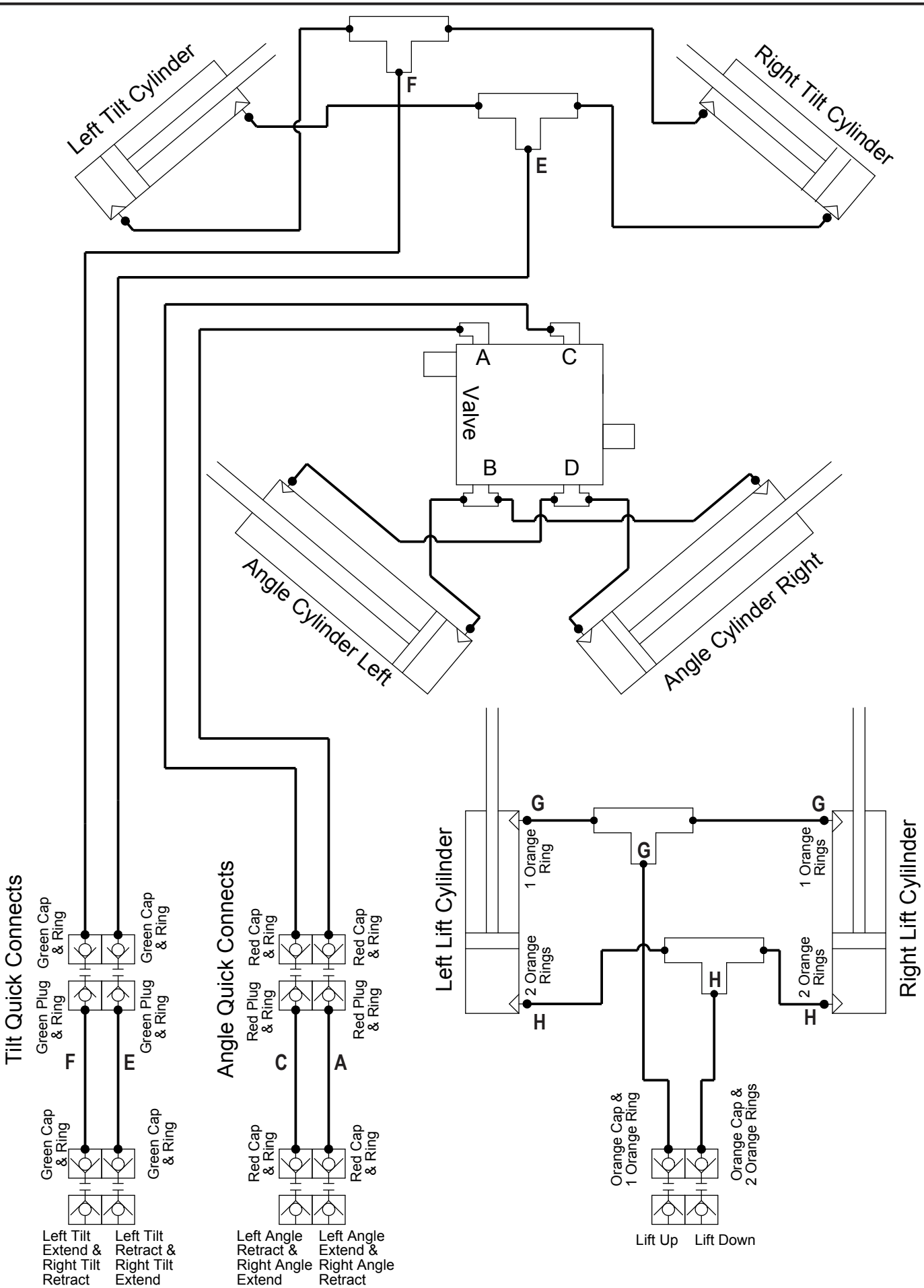

Tilt Quick Connects

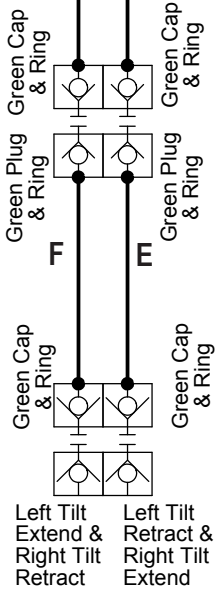

Angle Quick Connects

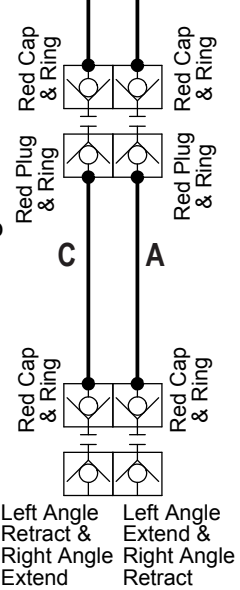

Female Quick Connects At Rear Of Tractor

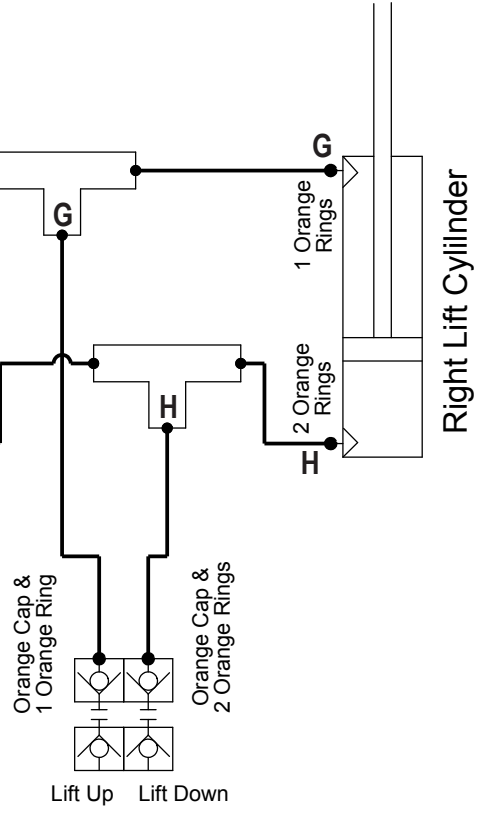



* Parts Not Shown

ITEM NO.	QTY.	PART NO.	DESCRIPTION
1	6	16-21064	3/8" x 1" Carriage Bolt Gr 5 NC
2	1	44-18995	Ag Pro 3-5M Name Plate
3*	1	44-15600	Custom Name Plate
4	6	70-20622	3/8" Flange Hex Nut Gr 5 NC

3-5 Blade Cylinders

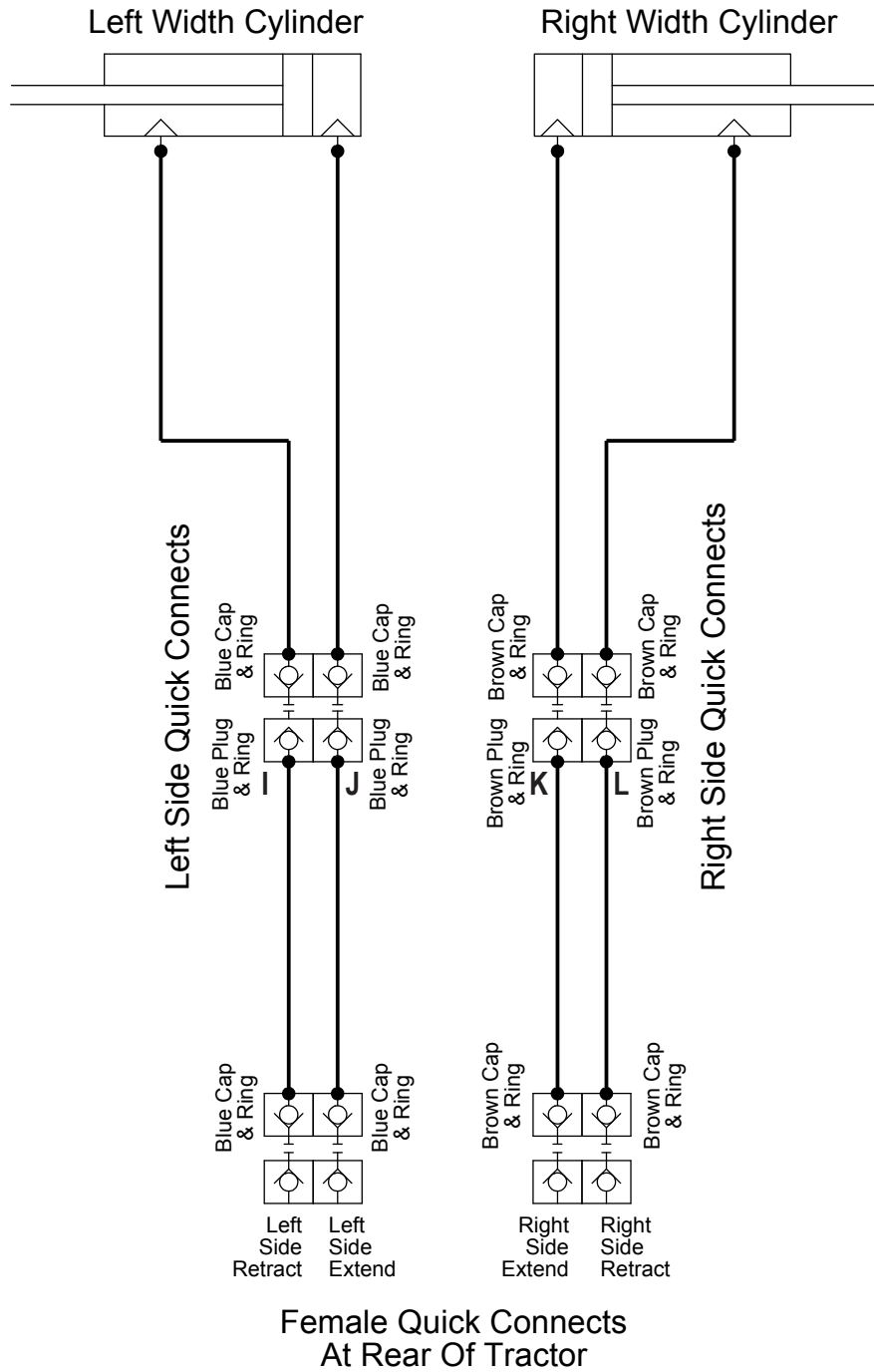

Before Each Use:

1. Disconnect the mobile half from the parking station and the cap from the fixed half.
2. Check that there is no contamination (salt, sand, dirt, etc.):
 - A. On the pins.
 - B. Inside the cam.
 - C. In the locking mechanism area.
 - D. On the face of the plates and couplings.
3. In case of contamination, remove it with a cloth and/or compressed air.
4. Check that there is still a lubricant/anti-corrosion (grease or silicone - see Note 1):
 - A. On the pins.
 - B. Inside the cam.
 - C. In the locking mechanism area.
5. Connect the mobile and fixed halves together.

Fixed Half

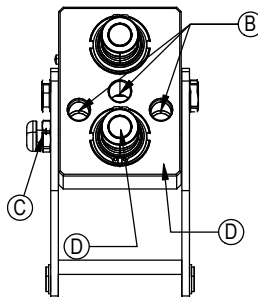

Mobile Half

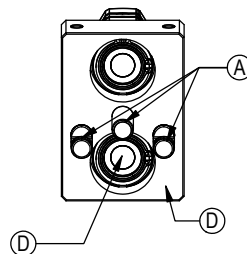

After Each Use:

1. Disconnect the mobile half from the fixed half.
2. Clean all contamination (salt, sand, dirt, etc.) from the following areas:
 - A. On the pins.
 - B. Inside the cam.
 - C. In the locking mechanism area.
 - D. On the face of the plates and couplings.

*Use a cloth or compressed air. It is advised to not use water to clean these surfaces
3. Apply a lubricant/anti-corrosion (grease or silicone - see Note 1):
 - A. On the pins.
 - B. Inside the cam.
 - C. In the locking mechanism area.
4. Connect the cap to the fixed half and the mobile half to the parking station.

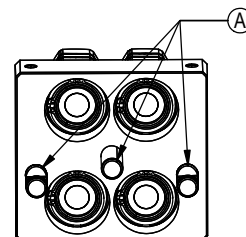
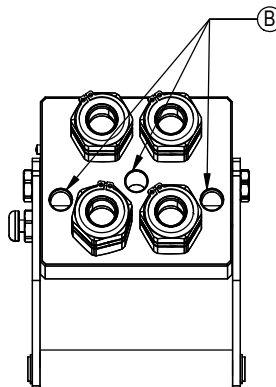

Note 1:

When sand and salt are present, or the plates under go a washdown, a heavy duty silicone spray lubricant should be used to replace grease from the factory. The lubricant should help protect from corrosion without collecting dust and contaminants, and will resist washing off when exposed to water.

Recommended Lubricant Brands:

Fluid Film (Aerosol or Non-Aerosol), LPS-2 Heavy Duty Lubricant, or CRC 3-36.

Cleaning The Male Interface Seal:



1. Make sure the coupling is securely fastened into the plate or place in a vice.
2. Using a blunt, non-marring tool, depress the valve face until the seal is exposed. Insert a bent metal wire between the valve face and the body of the coupling. Use caution not to damage or scratch the seal when inserting the wire.
3. Inspect the seal and interior surfaces for contamination.
4. In case of contamination, carefully wipe surfaces with a soft cloth, or use compressed air to blow the contamination out. Do Not press hard on the seal as contamination can scratch the seal surface.
5. Using a non-marring tool, depress the valve face and remove the metal wire. Release the valve to the flush position.

Cleaning The Female Bushing:



1. Make sure the coupling is securely fastened into the plate or place in a vice.
2. Using a non-marring tool, depress the outer ring to expose the bushing. There is no need to expose the valve seal, so stop pressing before the valve is opened.
3. Inspect the interior body and bushing surfaces for contamination.
4. In case of contamination, carefully wipe surfaces with a soft cloth, or use compressed air to blow the contamination out.
5. Release the outer ring so that it returns to the flush position.

Page Left Blank Intentionally

Page Left Blank Intentionally

Contact Us

As always, if you have any questions about your Ag Pro 3-5 Dozer or other products made by Grouser, feel free to contact us.

Grouser Products

755 2nd Ave NW - West Fargo, ND 58078

Phone: 1-800-747-6182

Fax: 1-701-282-8131

E-mail: grouser@grouser.com

Website: www.grouser.com

Improvements

Grouser Products Inc. is continually striving to improve its products. We reserve the right to change prices, specification, or equipment at any time without notice. We also reserve the right to make improvements or changes when it becomes practical and possible to do so without incurring any obligation to make changes or additions to the equipment sold previously.

Warranty

Grouser Products warrants to the original purchaser of each item that the product be free from defects in material and workmanship under normal use and service for a period of two years. If such equipment is found to be defective within two years, it is the obligation of Grouser Products under this warranty to repair or replace (exclusive of the cost of labor and transportation), any equipment or parts, in the judgment of Grouser Products to be defective in material or workmanship.

All equipment or parts claimed to be defective in material or workmanship must be made available for inspection at the place of business of a dealer authorized to handle the equipment covered by this warranty, or, upon request by Grouser Products, shipped to the Grouser Products factory in West Fargo, North Dakota. Grouser Products shall have no obligation to bear the cost of labor or transportation in connection with replacement or repair of any such defective parts in the setup process.

This warranty covers only defects in material and workmanship. It does not cover depreciation or damage caused by normal wear, accident, improper assembly, improper adjustments, improper maintenance including lack of proper lubrication, or improper use. Therefore, Grouser Products liability under this warranty shall not be effective or actionable unless the equipment is assembled, maintained and operated in accordance with the operating instructions accompanying the equipment. Grouser Products shall have no liability if the equipment has been altered or reworked without the written authorization of Grouser Products.

Grouser Products' parts, which are furnished under this warranty and properly installed, shall be warranted to the same extent as the original parts under this warranty if, and only if, such parts are found to be defective within the original warranty period covering the original equipment.

