

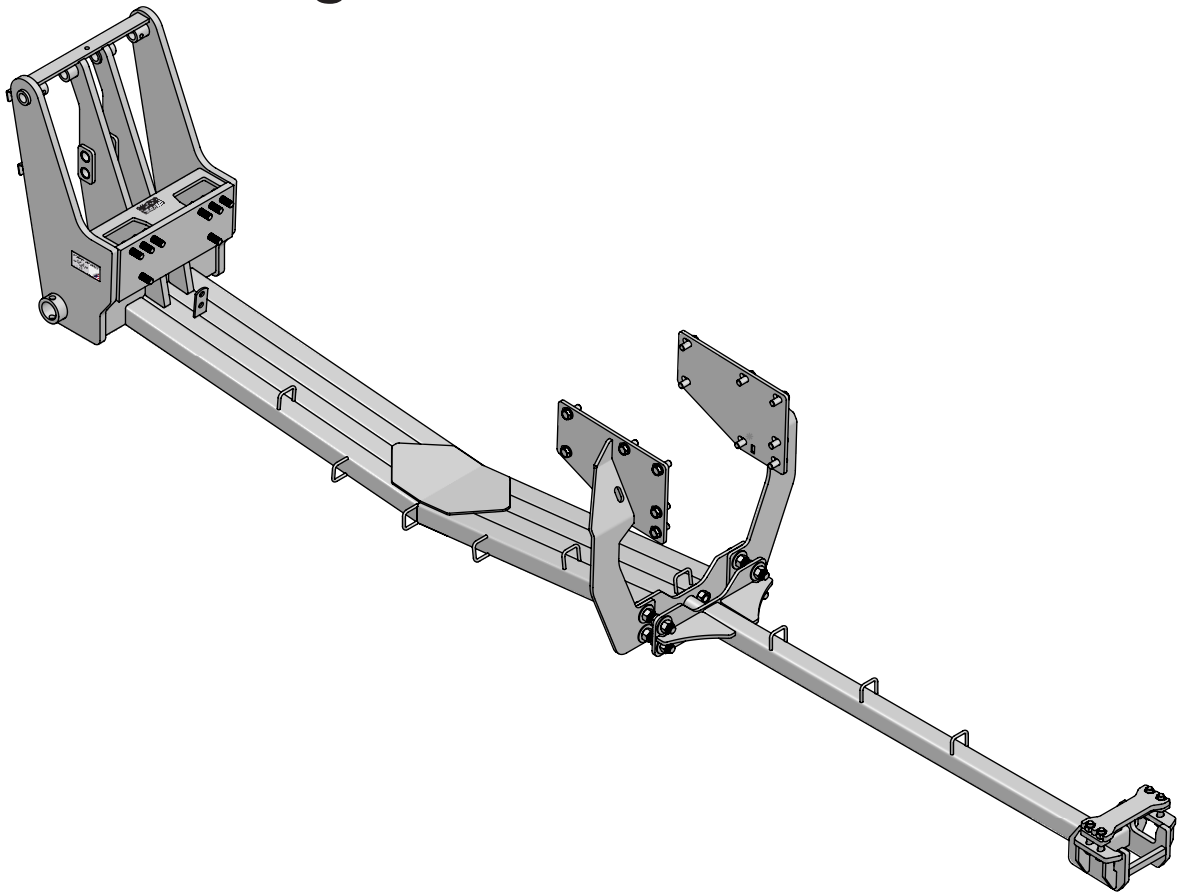

# *Case Magnum - Tier 4 & B Undercarriage Installation Instructions*



**For Models:**

**Case Magnum Standard & Suspended Front Axle  
(With 4" or 4.5" Rear Axles):**

235, 250, 260, 280, 290, 310, 315, 340

Purchase Date
Serial Number
Model Number
Tractor Model
Dealer

# To The Owner

This manual contains information concerning the installation of the undercarriage. You have purchased dependable, long lasting equipment, but only by proper care and operation can you expect to receive the performance and long service built into our products. Please have all operators read this manual carefully and keep the manual available for ready reference. If you have any questions or concerns, contact Grouser Products.

## Caution:

- Always use caution when working around any equipment.
- Always wear safety glasses.
- Follow tractor manufacturer's safety guidelines when installing this product.
- Use paint where necessary to prevent rust.
- Do not modify or permit anyone else to modify or alter the equipment and its components without first consulting Grouser Products.

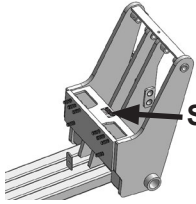

Serial Number Location

## Note:

- When installing hardware, only finger tighten until all hardware is in place.
- A full diagram of the assembly with the full list of parts is on pages 4-5.
- Unstrap and remove any components that are attached for shipping.
- Read all instructions prior to performing installation.
- Tractor frame not shown in some diagrams for clarity.



To ensure the safety of those working under and around the machine, apply parking brake, remove key from ignition, and block tires before working on the machine.

## Installation

1. Remove weights and weight bracket from front of tractor if necessary.
2. Position undercarriage under tractor and center on frame of tractor.



**Caution:** When lifting undercarriage, watch for any potential pinching of hoses or any other components to prevent any damage.

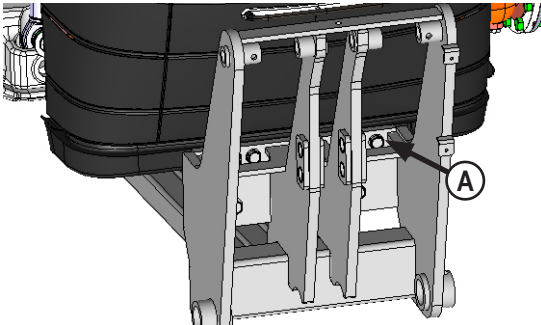

3. Lift undercarriage and attach front of undercarriage to tractor with 8 - 20mm x 70mm bolts and 8 - 3/4" flat washers (A).

**NOTE:** If tractor has Standard Front Axle, continue with Step #7.

### Suspended Front Axle Installation Only:

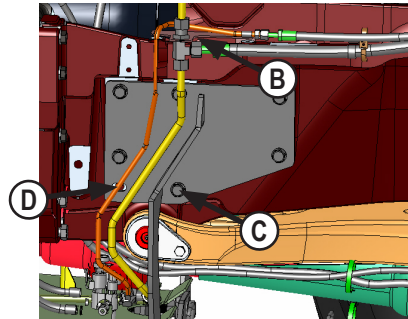

4. Loosen bracket that holds steel line on right side of tractor engine (B). This allows room for side plate to be installed.
5. Attach side brackets to tractor with 13 - 20mm x 50mm bolts and 13 - 3/4" flat washers (C). Eliminate bottom left bolt on right side plate due to steel line obstruction (D).
6. Continue with Step #8.

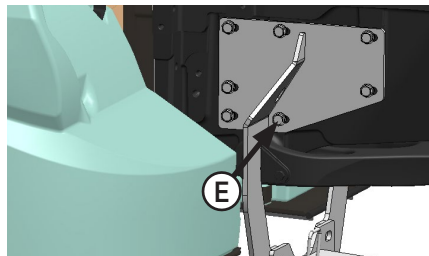

7. Attach side brackets to tractor with 14 - 20mm x 50mm bolts and 14 - 3/4" flat washers (E).

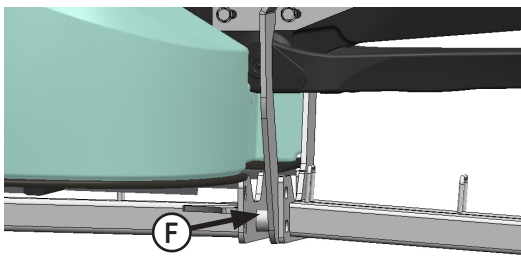

8. Position push pole under tractor.
9. Slide front of push pole onto rod at end of undercarriage (F).

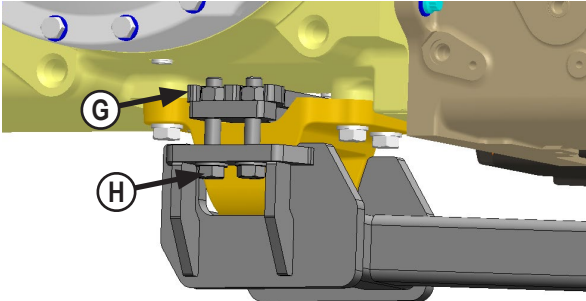

10. Place clamp weld bracket on top of drawbar bracket (G).  
**NOTE: The drawbar pin may have to be lowered to get bracket in place. Reinstall after bracket is in place.**
11. Raise rear of push pole up to drawbar bracket and attach to clamp weld bracket with 4 - 3/4" x 4" bolts, 4 - 3/4" flat washers and 4 - 3/4" center lock nuts (H).
- NOTE: Verify that push pole is touching the front and back of drawbar bracket.**

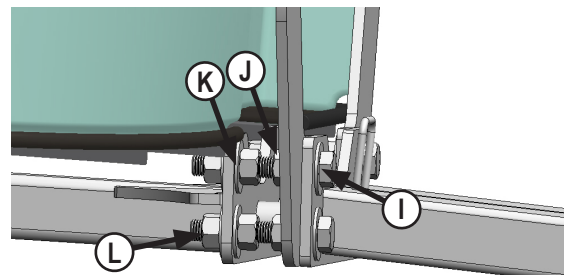

12. Install 4 - 1" x 6" bolts and 4 - 1" flat washers through the rear of undercarriage and side plates (F). Do Not insert bolts fully through push pole until nuts (J & K) are installed in next step.
13. Install 8 - 1" flat washers and 8 - 1" nuts on 1" bolts from Step #12. 4 of the washers should be against side plates (J) and the other 4 washers should be against push pole (K).
- NOTE: See exploded view on pages 4-5 for further clarification.**
14. After 1" bolts are through the push pole, install 4 - 1" flat washers and 4 - 1" nuts (L).
15. Torque rear 3/4" bolts (H) to 100 ft-lbs.
16. Torque the front 20mm bolts (A) to 432 ft-lbs.
17. Torque 1" nuts attaching side plates to undercarriage (J) to 909 ft-lbs.
18. Torque the side 20mm bolts (C or E) to 432 ft-lbs.
- NOTE: Suspended front axle - Tighten bracket that was loosened in Step #4 (B).**
20. Tighten inside 1" nuts (K) against the push pole plate. Plus an additional 1/2 turn.
21. Torque outside 1" nuts (L) to 909 ft-lbs.
22. Route hoses through hose loops on the undercarriage and push pole to the back of the tractor.
23. Protect the hoses around sharp corners and moving objects. Use zip ties to secure the hoses in place.
24. Plug the hoses into the open SCV's at the rear of the tractor.

## Assembling Lift Components

1. Refer to the Blade Owner's Manual & Parts Book for instructions on how to assemble the lift components.

## Maintenance

1. After first 8 hours of use, re-torque all bolts.
2. Check all fasteners regularly to ensure proper operation of equipment.
3. Inspect all equipment for existing or potential damages every 10 hours or less.

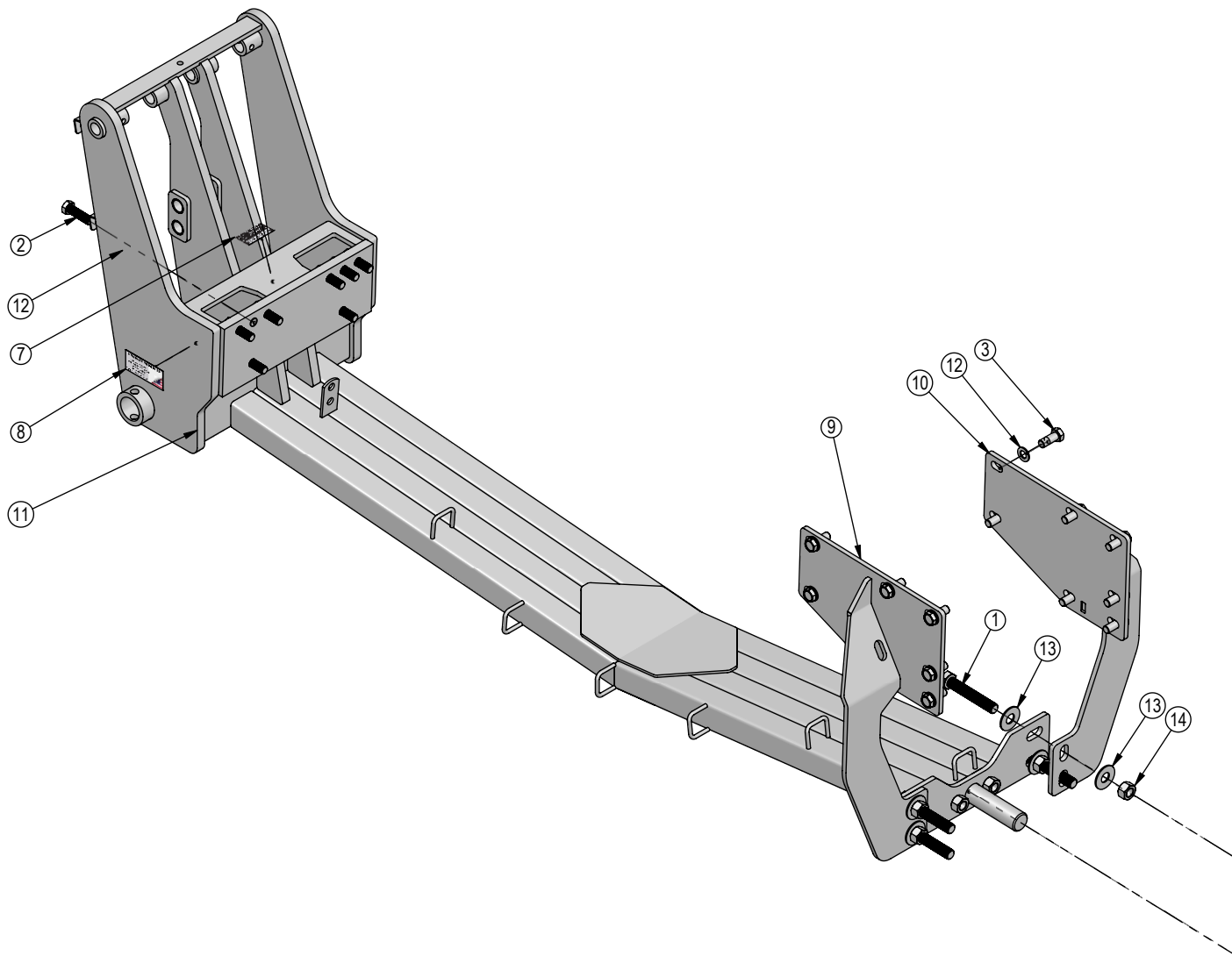

ITEM NO.	QTY.	PART NO.	DESCRIPTION
1	4	16-17271	1" X 6" Hex Bolt Gr 8 NC (Full Thread)
2	8	16-1876	20mm x 2.5mm x 70mm Gr. 10.9 Hex Bolt
3	14	16-1878	20mm x 2.5mm x 50mm Hex Bolt Gr. 10.9
4	4	16-20226	3/4" X 4" Hex Bolt Gr. 5 NC
5	1	17-42090	Push Pole Weld
6	1	18-42245	Clamp Weld
7	1	NA	Grouser Dozer Metal Serial Tag
8	1	27-18887	Grouser Name Plate Decal
9	1	44-14933-L	Side Plate, Left
10	1	44-14933-R	Side Plate, Right
11	1	54-14910	Undercarriage Weld
12	26	57-20757	3/4" Flat Washer - 1-1/2" OD
13	16	57-20819	1" Flat Washer Heavy Duty Gr 8
14	12	70-20599	1" Hex Nut Gr 8 NC
15	4	70-20607	3/4" Center Lock Hex Nut Gr 2 NC

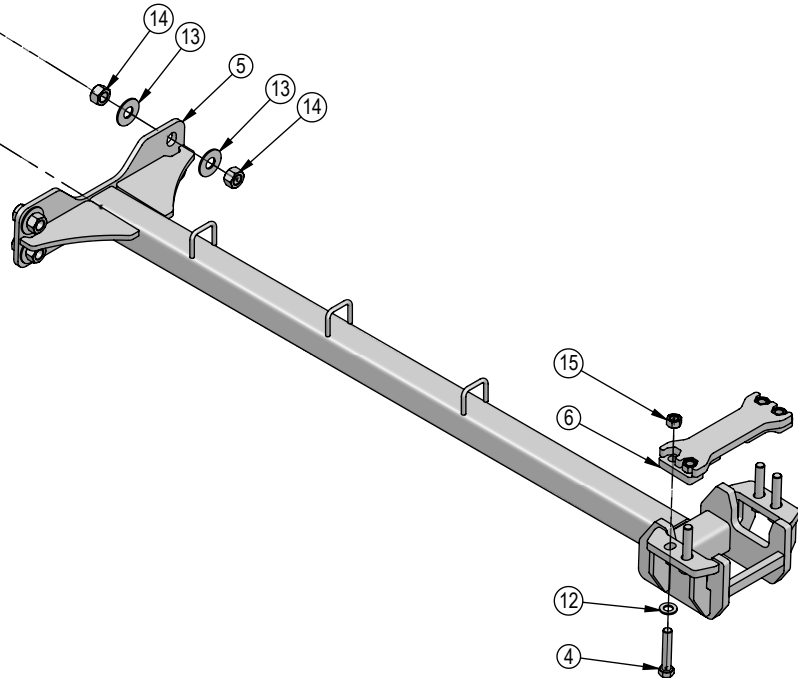

DWG. NO.: 42445-A

# Notes

---

---

# Notes

---

---

# Improvements

---

---

Grouser Products Inc. is continually striving to improve its products. We reserve the right to change prices, specification, or equipment at any time without notice. We also reserve the right to make improvements or changes when it becomes practical and possible to do so without incurring any obligation to make changes or additions to the equipment sold previously.

## Warranty

---

---

Grouser Products warrants to the original purchaser of each item that the product be free from defects in material and workmanship under normal use and service for a period of **two (2) years for Agriculture Series Blades and one (1) year for Heavy Duty Series from date of original retail delivery.**

### **The obligation of the consumer under this warranty:**

1. To read the operators manual and to operate, lubricate, maintain and store equipment in accordance with the instructions listed in the operators manual.
2. To inspect equipment and if any part needs repair or replacement when continued use would cause damage or wear to other parts or safety.
3. All equipment or parts claimed to be defective in material or workmanship must be made available for inspection at the place of business of a dealer authorized to handle the equipment covered by this warranty, or, upon request by Grouser Products, shipped to the Grouser Products factory in West Fargo, North Dakota.

### **The obligation of the dealer under this warranty:**

1. Complete warranty registration form and submit within 30 days of sale.
2. Contact Grouser Products for authorization prior to performing any warranty repairs or part replacement.
3. Complete warranty request form and submit with photos and supporting documentation.

### **The obligation of Grouser Products under this warranty:**

1. Repair or replace, any equipment or parts, in the judgment of Grouser Products to be defective in material or workmanship.
2. Grouser Products will cover the cost of parts and ground shipping at dealer invoice only.
3. Grouser Products shall have no obligation to bear the cost of labor or transportation in connection with replacement or repair of any such defective parts.

### **This warranty does not cover:**

1. Depreciation or damage caused by normal wear, accident, improper assembly, improper adjustments.
2. Improper maintenance including lack of proper lubrication, or improper use. Including loose bolts, nuts, or fitting due to over tightening or vibration after 20 hours of operation.
3. Repairs or alterations without authorization from a Grouser Products representative.
4. Grouser Products shall have no liability if the equipment has been altered or reworked without the written authorization of Grouser Products.

Grouser Products' parts, which are furnished under this warranty and properly installed, shall be warranted to the same extent as the original parts under this warranty if, and only if, such parts are found to be defective within the original warranty period covering the original equipment.

**NO EMPLOYEE OR REPRESENTATIVE OF GROUSER PRODUCTS IS AUTHORIZED TO CHANGE THE WARRANTY IN ANY WAY OR GRANT ANY OTHER WARRANTY.**

## Contact Us

---

---

As always, if you have any questions about your system or other products made by Grouser, feel free to contact us.



755 2nd Ave NW - West Fargo, ND 58078  
+1 701-282-7710 | [info@grouser.com](mailto:info@grouser.com)  
[www.grouser.com](http://www.grouser.com)