

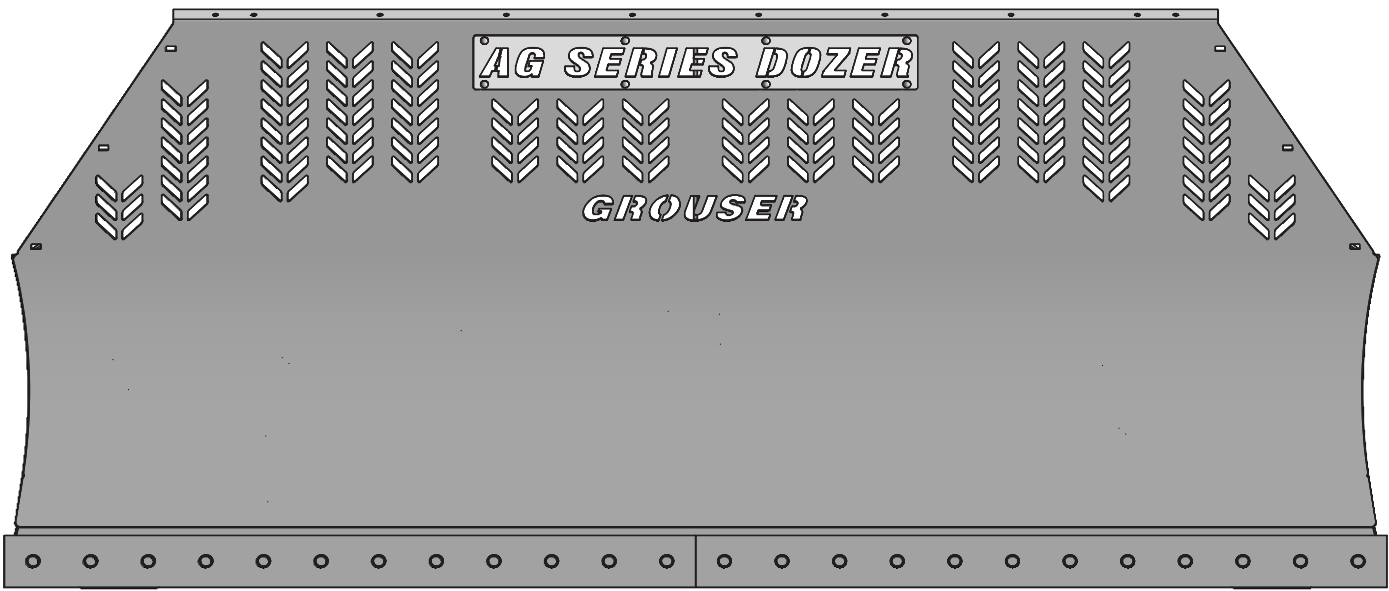

AG240 Dozer with FH-440 Front Hitch Owner's Manual & Parts Book



Grouser Products
755 2nd Ave NW - West Fargo, ND 58078
Phone: 1-800-747-6182
Fax: 1-701-282-8131
E-mail: grouser@grouser.com
Website: www.grouser.com

Purchase Date
Serial Number
Model Number
Tractor Model
Dealer

Description	Page
Welcome To The Owner _____	2
Safety Precautions, Torque Specifications & Abbreviation Key _____	3
Decals _____	4
Maintenance & Lubrication _____	5
Connecting and Disconnecting the Blade & Tilt Plate & Skid Shoe Adjustment _____	6
10'-16' No Angle-No Tilt Blade Assembly _____	9
12'-16' Hydraulic Angle-Hydraulic Tilt Blade Assembly _____	8
10'-16' Hydraulic Angle-No Tilt Blade Assembly _____	9
Hydraulic Angle-Hydraulic Tilt or Hydraulic Angle No Tilt System _____	10-11
Lift System _____	12-13
Quick Attach System _____	14
Tractor Side Hydraulics _____	15
Blade Options _____	16-17
Replacement Parts _____	18
HAHT Hydraulic Multi-Coupler Option _____	19
HANT Hydraulic Multi-Coupler Option _____	20
Hydraulic Multi-Coupler Maintenance _____	21-22
Hydraulic Schematic _____	23
Contact Us, Improvements, & Warranty _____	24

Thank you for your recent purchase of a Grouser dozer blade. Welcome to the family of satisfied Grouser blade owners. Grouser Products is committed to offering quality products to help professionals in their daily jobs. We are also committed to providing you the highest level of customer satisfaction possible. Again, thank you for your patronage. We look forward to serving you.

This manual contains information concerning the operation, adjustment, safety and maintenance of the AG240 Dozer and FH-440 Front Hitch. You have purchased a dependable, long lasting piece of equipment. You can expect to receive long lasting performance and long service built into our products with proper care and operation. Please have all operators read and understand this manual carefully. Keep the manual available for reference. If, for any reason, you have questions or comments, we would be happy to hear from you. Call our toll-free number, 800-747-6182, or send us an e-mail at info@grouser.com. You can expect us to respond to your e-mail in a timely manner.

A careful operator is the best operator. Most accidents can be avoided by observing certain precautions. To help prevent accidents, read and take the following precautions before operating this equipment. In addition, please follow all safety and operational instructions of your tractor manufacturer.

The Dozer:

1. The AG240 Dozer and FH-440 Front Hitch should be operated only by those who are responsible and instructed to do so.
2. Read the owner’s manual carefully before using this equipment. Lack of operating knowledge can lead to accidents.
3. Keep the dozer maintained in reliable and satisfactory condition to ensure your safety.
4. Make sure the area is clear of people before moving any equipment.
5. Do not modify or permit anyone else to modify or alter the equipment and its components without first consulting Grouser Products.
6. Lower the blade to the ground when not in use.

Servicing the Dozer:

1. Read and follow all safety instructions provided by the tractor manufacturer.
2. Always use proper personal safety gear when performing maintenance on equipment.
3. Before servicing, relieve hydraulic pressure, stop engine and fully engage parking brake.
4. Escaping hydraulic fluid under pressure can penetrate skin causing serious injury. If fluid is injected into skin, obtain medical attention immediately.
 - DO NOT use your hand to check for leaks. Use a piece of cardboard or paper to search for leaks.
 - Stop the engine and relieve pressure before connecting or disconnecting lines.
 - Tighten all connections before starting the engine or pressurizing lines.

Storing the Dozer:

1. Thoroughly clean the inside and outside of the dozer before storage. Use paint where necessary to prevent rust.
2. Check the dozer for worn or damaged parts. Install new parts as required.
3. Lubricate all pins and joints.

Tighten all bolts to the values listed below unless otherwise noted. Refer to the parts lists for proper length and grade of the bolts.

Size	Torque - Dry (ft-lbs)			
	SAE Grade 5		SAE Grade 8	
	UNC	UNF	UNC	UNF
5/16	17	19	24	27
3/8	30	35	45	50
7/16	50	55	70	80
1/2	75	85	110	120
9/16	110	120	150	170
5/8	150	170	210	240
3/4	260	300	380	420
7/8	430	470	600	670
1	640	720	910	1020

Size	Torque - Dry (ft-lbs)
	Grade 10.9
M18 x 2.50	284
M20 x 2.50	401
M22 x 2.50	547
M24 x 3.00	694

Angle/Tilt Function Abbreviation Key		
HAHT	Hydraulic Angle - Hydraulic Tilt	6-Way
HANT	Hydraulic Angle - No Tilt	4-Way
NANT	No Angle - No Tilt	2-Way

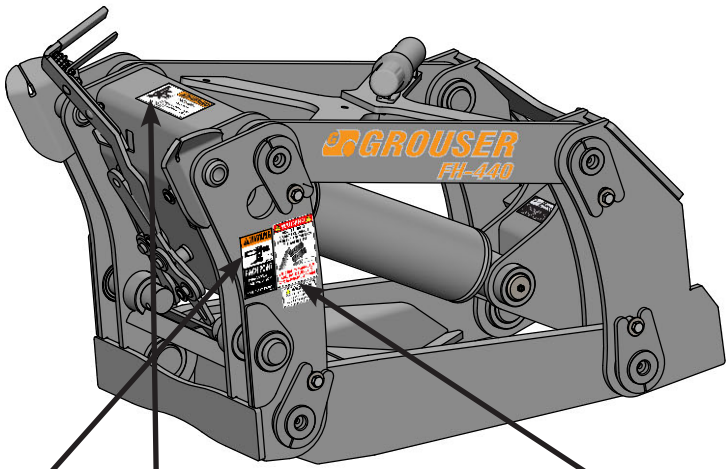

WARNING

PINCH POINT
AVOID INJURY FROM
FRAME PIVOT AND STOPS.

- Keep hands and feet away.

27-9503

PN: 27-9503
Left and Right Side

WARNING

PINCH AREA
Keep away

Failure to comply could
result in death or serious
injury.

27-2409

PN: 27-2409

WARNING

**INSURE THERE IS
ADEQUATE CLEARANCE
BETWEEN TIRES AND BACK
OF BLADE SYSTEM**

**SEE OWNER'S MANUAL FOR
CORRECT EXTENSION TO
GAIN ADEQUATE CLEARANCE**

27-40425

PN: 27-40425
See Page 15 for
Extension

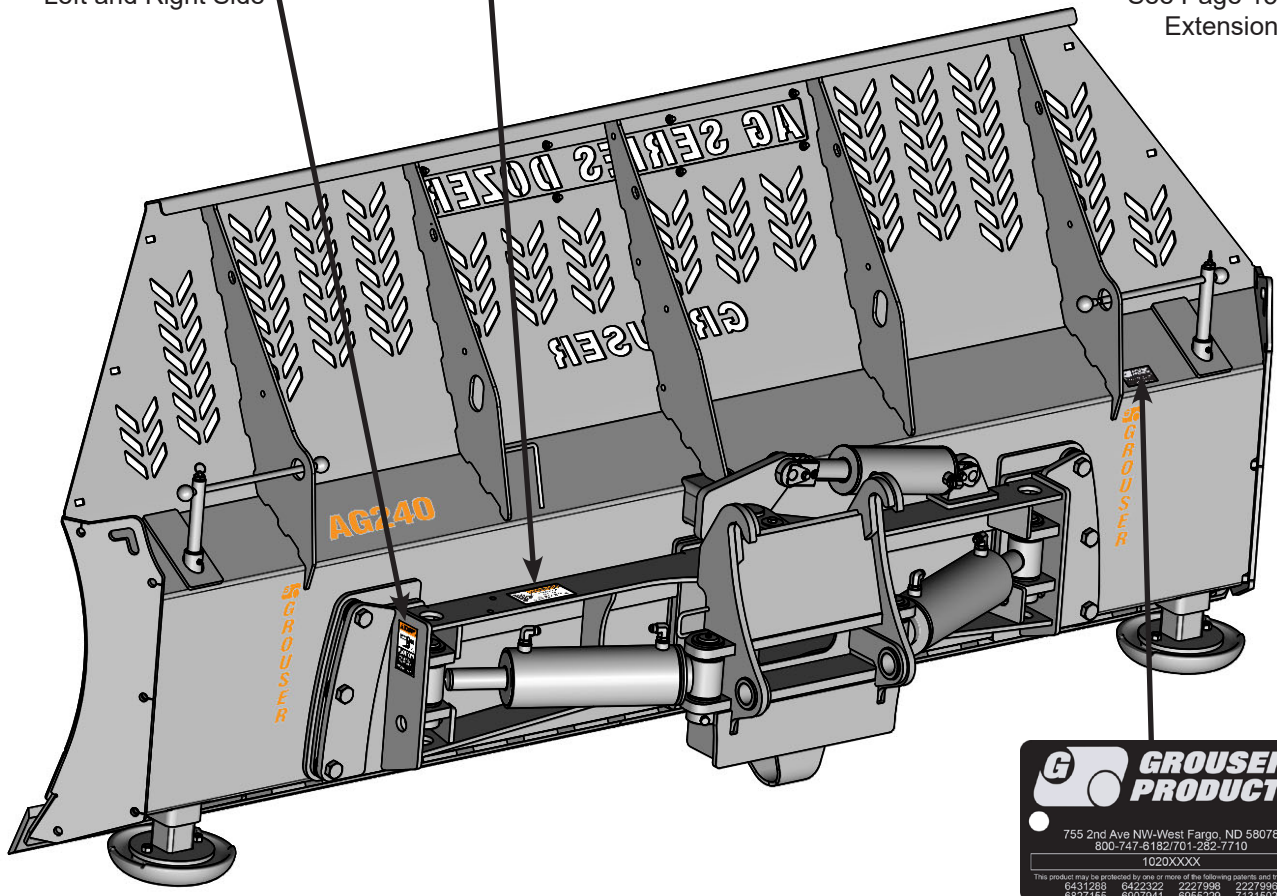

GROUSER PRODUCTS

755 2nd Ave NW-West Fargo, ND 58078
800-747-6182/701-282-7710

1020XXXX

This product may be protected by one or more of the following patents and trademarks:
6451288 6422322 2227388 2227998
6827155 6807941 6856229 7131502

Due to the harsh environment this equipment operates in, the following tasks should be performed every 10 hours or less.

- Inspect all equipment before operation for existing or potential damage.
- Lubricate all joints with high quality grease. See below for grease locations.
- Inspect all bolts, and tighten any loose bolts to torque specifications on page 3.
- Check replaceable cutting edge for wear ensuring there is enough material to prevent permanent damage to the blade.
- Check hydraulic cylinders and hoses for damage or leaks. For replacement parts, see hydraulic pages for your specific system.
- If equipped with hydraulic multi-coupler, see page 19-20 for hydraulic multi-coupler maintenance.
- Make sure all non-rotating pins are secured properly.
- Inspect all decals and order replacement decals from your dealer if any are damaged or worn.
- Check skid shoes for wear and replace if necessary. For adjustment, see page 6.
- Inspect all tilt-ways for wear. See page 6 for tilt plate adjustment.
- Replace parts with original parts only.

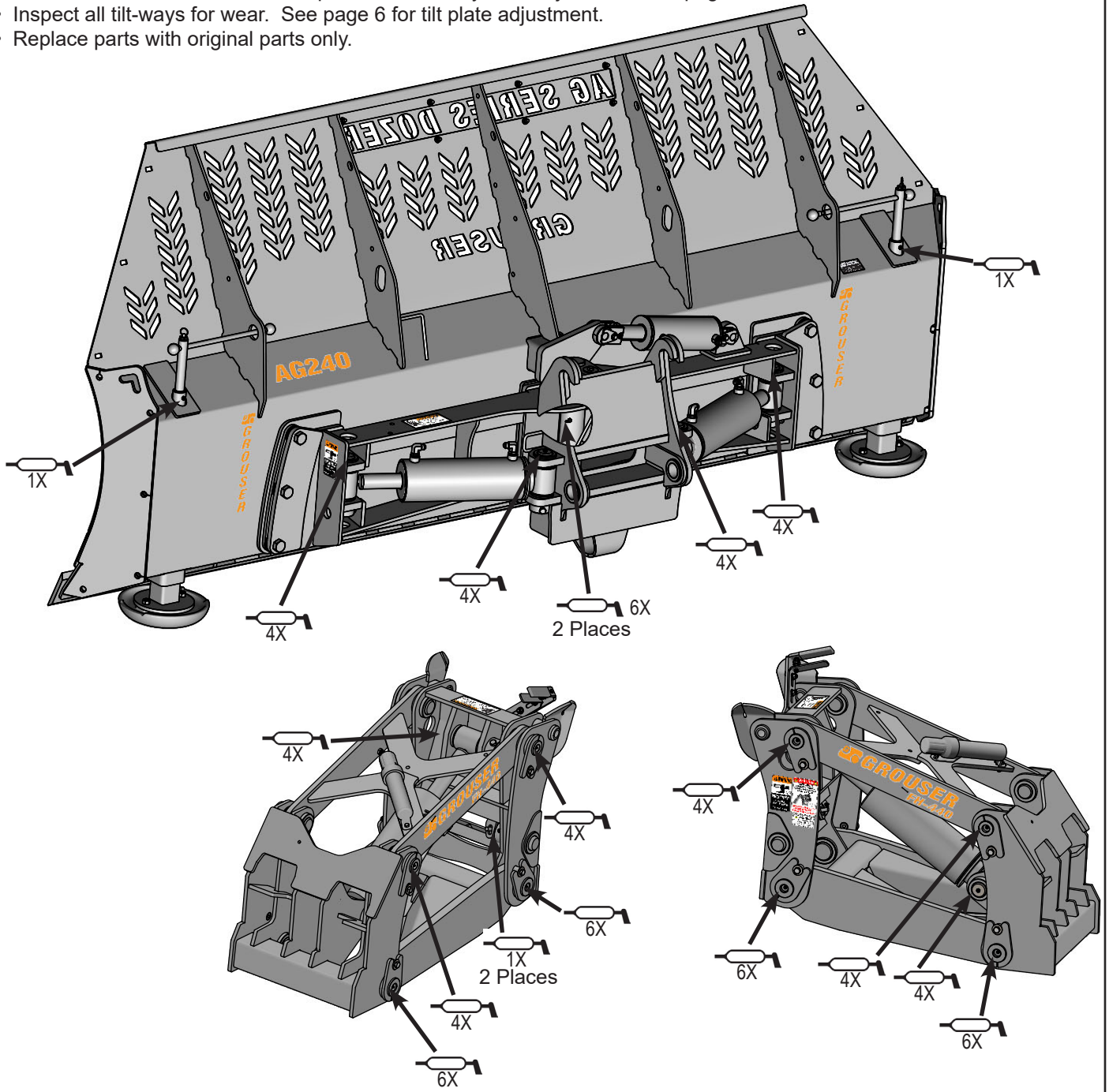

	Grease Locations
Hydraulic Angle & Hydraulic Tilt	10
Hydraulic Angle & No Tilt	10
No Angle & No Tilt	4
Lift System	12

NOTE: Only the HAHT system is shown.
 HAHT and HANT have similar grease locations.
 NANT only has grease locations on the ratchet jacks.

To Connect:

Note: If necessary, use a spotter to help center the blade on the lift system.

1. Lift the locking latch and push the quick attach lock handle on the left side of the lift system to open the quick attach system. Refer to Page #12 for further clarification on the quick attach system.
2. Drive the tractor forward slowly until the top edge of the male quick attach is under the top angle frame hook.
3. Raise the lift system until the male quick attach engages the angle frame hooks. Continue to raise the lift system until the blade is off the ground and the angle frame is against the front of the male quick attach.
4. Shut off the tractor engine and set the parking brake.
5. Pull the quick attach lock handle to engage the quick attach pins and lift the locking latch to lock the handle in place.
6. Clean and connect hydraulic couplers on the top arm. Refer to Page #13 for proper locations of all functions.

To Disconnect:

1. Lower the blade until the cutting edge is off the ground a few inches.
2. Shut off the tractor engine and set the parking brake.
3. Unhook all of the hydraulic couplers on the top arm.
4. Lift the locking latch and push the quick attach lock handle to disengage the quick attach pins.
5. Start tractor, disengage the parking brake, and lower the blade until cutting edge is on the ground.
6. Continue to slowly lower the lift system to disengage the blade.
7. Slowly back away from the blade. When lift system is clear from the blade, raise the lift system.
8. Shut off the tractor engine and set the parking brake.
9. Pull the quick attach lock handle and lift the locking latch to lock the handle in place.

Note: Do not remove all of the bolts at the same time.

1. The preferred blade position for adjusting the tilt plates is laying face down on blocks.
2. Remove the top and bottom bolts from each tilt plate.
3. Add or remove washers as needed to adjust tilt-way clearance to 1/16" - 1/8".
4. Reinstall top and bottom bolts.
5. Follow Steps #2-4 for the center bolts.
6. Once the tilt-way clearance is set, torque bolts to 640 ft-lbs.

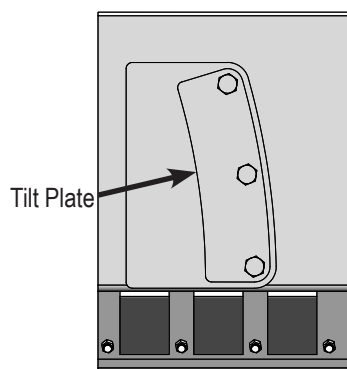
**Skid Shoe Adjustment:**

1. Pull up on the retractable plunger on the top of the threaded rod to release the handle.
2. Slide the handle out from the locking position on the blade.
3. Turn the handle to adjust the skid shoe to the preferred height.
4. Place the handle back in the hole on the blade and lock in place with the retractable plunger.

ITEM NO.	PART NO.	10' QTY.	12' QTY.	14' QTY.	16' QTY.	DESCRIPTION
1	11-11316	1	1	1	1	Arm, Blade Stand
2	15-41950-10	1	-	-	-	240 2-Way Blade Weld
2	15-41950-12	-	1	-	-	240 2-Way Blade Weld
2	15-41950-14	-	-	1	-	240 2-Way Blade Weld
2	15-41950-16	-	-	-	1	240 2-Way Blade Weld
3	16-20558	1	1	1	1	1" x 2" Hex Bolt Gr. 8 NC
4	16-21666	24	28	32	36	5/8" x 1-3/4" Plow Bolt Gr 5 NC
5	27-17262	1	1	1	1	Ag 240 Decal
6	27-40962	1	1	1	1	Warning Prop 65 Decal
7	27-9505	2	2	2	2	Grouser Vertical Decal
8	NA	1	1	1	1	Grouser Dozer Metal Serial Tag
9	29-7950-5	2	-	-	-	Cutting Edge
9	29-7950-6	-	2	-	-	Cutting Edge
9	29-7950-7	-	-	2	-	Cutting Edge
9	29-7950-8	-	-	-	2	Cutting Edge

ITEM NO.	PART NO.	10' QTY.	12' QTY.	14' QTY.	16' QTY.	DESCRIPTION
10	34-40852	2	2	2	2	Retractable Spring Plunger, 3/8"
11	34-40853	4	4	4	4	Knob, 1-1/2" Ball
12	34-40859	2	2	2	2	Spring Clip, 1-3/16"
13	40-40739	2	2	2	2	Skid Shoe Mount, 240
14	43-7767	1	1	1	1	Cylinder Pin Clip
15	43-9582	1	1	1	1	Pin
16	50-15458	2	2	2	2	12" Round Mushroom Skid Shoe
17	50-40855	2	2	2	2	Threaded Rod, Skid Shoe
18	50-40857	2	2	2	2	Handle, Skid Shoe
19	58-9369	2	2	2	2	Straight 1/8" NPT Grease Zerk
20	70-20609	1	1	1	1	1" Hex Center Lock Nut Gr.2 NC
21	70-20646	24	28	32	36	5/8" Hex Top Lock Nut Gr 5 NC

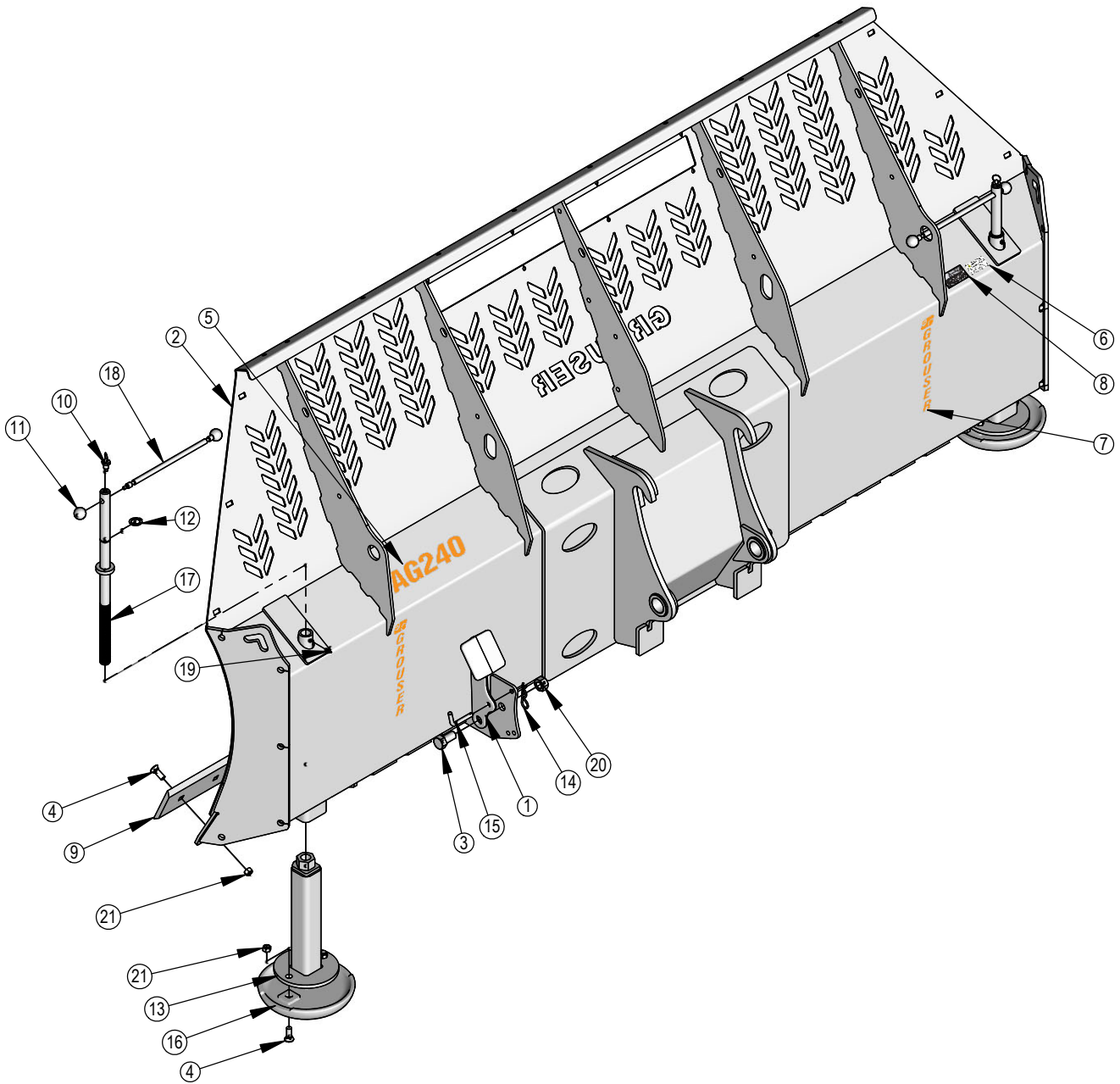

12'-16' Hydraulic Angle-Hydraulic Tilt Blade Assembly

ITEM NO.	PART NO.	12' QTY.	14' QTY.	16' QTY.	DESCRIPTION
1	15-41815-12	1	-	-	240 Blade Weld - 12'
1	15-41518-14	-	1	-	240 Blade Weld - 14'
1	15-41815-16	-	-	1	240 Blade Weld - 16'
2	16-20560	6	6	6	1" x 2-1/2" Hex Bolt Gr 8 NC
3	16-20562	1	1	1	1" x 3" Hex Bolt Gr.8 NC
4	16-21064	8	8	8	3/8" x 1" Carriage Bolt Gr 5 NC
5	16-21666	28	30	32	5/8" x 1-3/4" Plow Bolt Gr 5 NC
6	19-7774	1	1	1	1" x 1" Spring Bushing
7	27-17262	1	1	1	Ag 240 Decal
8	27-40962	1	1	1	Warning Prop 65 Decal
9	27-9505	2	2	2	Grouser Vertical Decal
10	NA	1	1	1	Grouser Dozer Metal Serial Tag
11	29-7950-6	2	-	-	Cutting Edge
11	29-7950-7	-	2	-	Cutting Edge
11	29-7950-8	-	-	2	Cutting Edge

ITEM NO.	PART NO.	12' QTY.	14' QTY.	16' QTY.	DESCRIPTION
12	34-40852	2	2	2	Retractable Spring Plunger, 3/8"
13	34-40853	4	4	4	Knob, 1-1/2" Ball
14	34-40859	2	2	2	Spring Clip, 1-3/16"
15	40-40739	2	2	2	Skid Shoe Mount, 240
16	44-15339	1	1	1	Back Drag Plate
17	44-16880	1	1	1	Ag Series Name Plate
18*	44-14830	1	1	1	Custom Name Plate
19	50-15458	2	2	2	12" Round Mushroom Skid Shoe
20	50-40855	2	2	2	Threaded Rod, Skid Shoe
21	50-40857	2	2	2	Handle, Skid Shoe
22	52-8204	2	2	2	240 Tilt Plate
23	57-20749	18	18	18	1" Flat Washer
24	58-9369	2	2	2	Straight 1/8" NPT Grease Zerk
25	70-20622	8	8	8	3/8" Flange Hex Nut Gr 5 NC
26	70-20646	28	30	32	5/8" Hex Top Lock Nut Gr 5 NC

* Part Not Shown

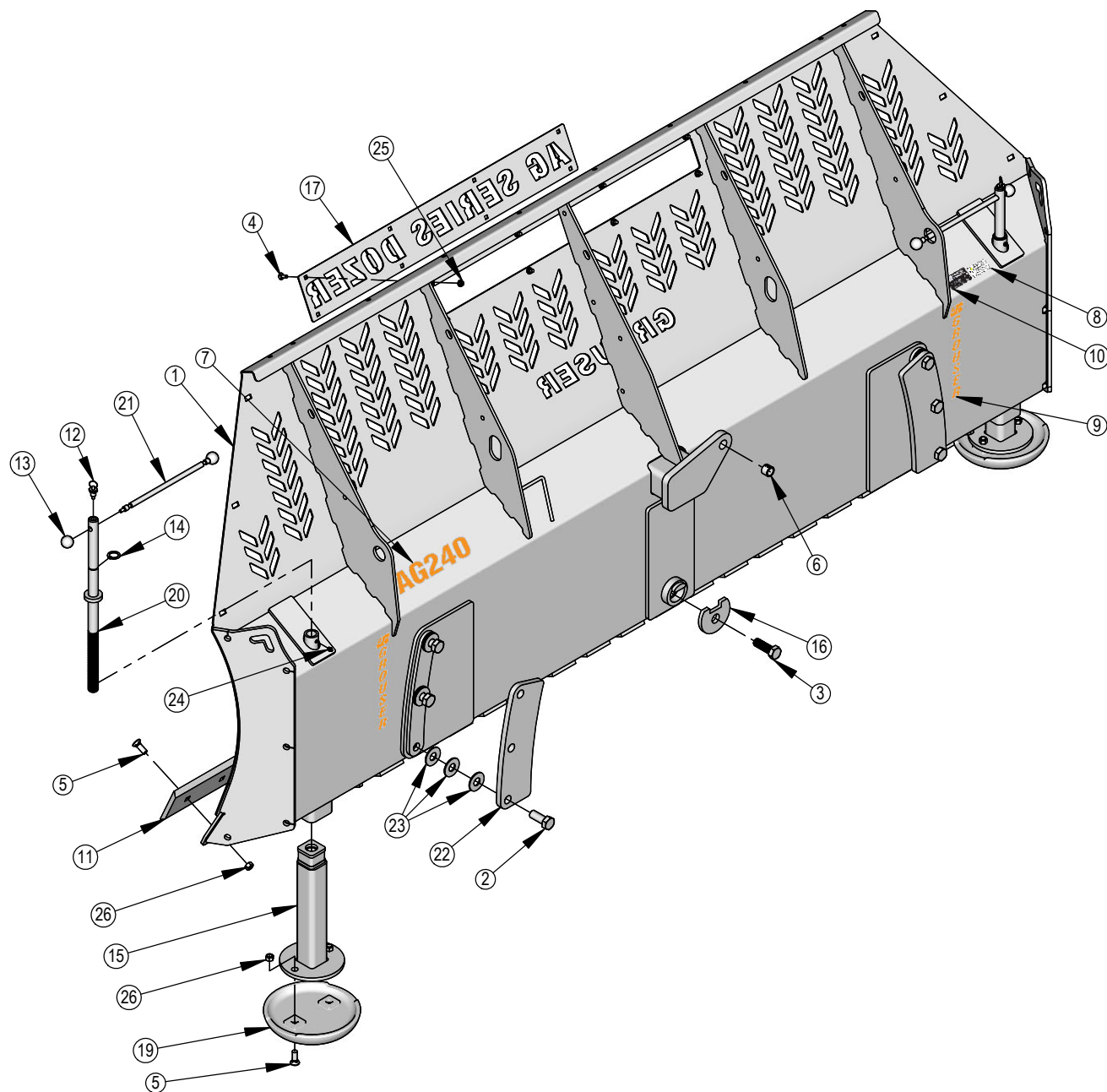

ITEM NO.	PART NO.	10' Qty.	12' Qty.	14' Qty.	16' Qty.	DESCRIPTION
1	15-42385-10	1	-	-	-	240 HANT Blade Weld
1	15-42385-12	-	1	-	-	240 HANT Blade Weld
1	15-42385-14	-	-	1	-	240 HANT Blade Weld
1	15-42385-16	-	-	-	1	240 HANT Blade Weld
2	16-20559	8	8	8	8	1" x 2-1/4" Hex Bolt Gr 8 NC
3	16-21064	8	8	8	8	3/8" x 1" Carriage Bolt Gr 5 NC
4	16-21666	24	28	30	32	5/8" x 1-3/4" Plow Bolt Gr 5 NC
5	17-42380	1	1	1	1	Center Adjustable Mount
6	27-17262	1	1	1	1	Ag 240 Decal
7	27-40962	1	1	1	1	Warning Prop 65 Decal
8	27-9505	2	2	2	2	Grouser Vertical Decal
9	NA	1	1	1	1	Grouser Dozer Metal Serial Tag
10	29-7950-5	2	-	-	-	Cutting Edge
10	29-7950-6	-	2	-	-	Cutting Edge
10	29-7950-7	-	-	2	-	Cutting Edge
10	29-7950-8	-	-	-	2	Cutting Edge

ITEM NO.	PART NO.	10' Qty.	12' Qty.	14' Qty.	16' Qty.	DESCRIPTION
11	34-40852	2	2	2	2	Retractable Spring Plunger, 3/8"
12	34-40853	4	4	4	4	Knob, 1-1/2" Ball
13	34-40859	2	2	2	2	Spring Clip, 1-3/16"
14	40-40739	2	2	2	2	Skid Shoe Mount, 240
15	44-16880	1	1	1	1	Ag Series Name Plate
16	50-15458	2	2	2	2	12" Round Mushroom Skid Shoe
17	50-40855	2	2	2	2	Threaded Rod, Skid Shoe
18	50-40857	2	2	2	2	Handle, Skid Shoe
19	57-20819	8	8	8	8	1" Flat Washer Heavy Duty Gr 8
20	58-9369	4	4	4	4	Straight 1/8" NPT Grease Zerk
21	70-20622	8	8	8	8	3/8" Flange Hex Nut Gr 5 NC
22	70-20646	24	28	30	32	5/8" Hex Top Lock Nut Gr 5 NC

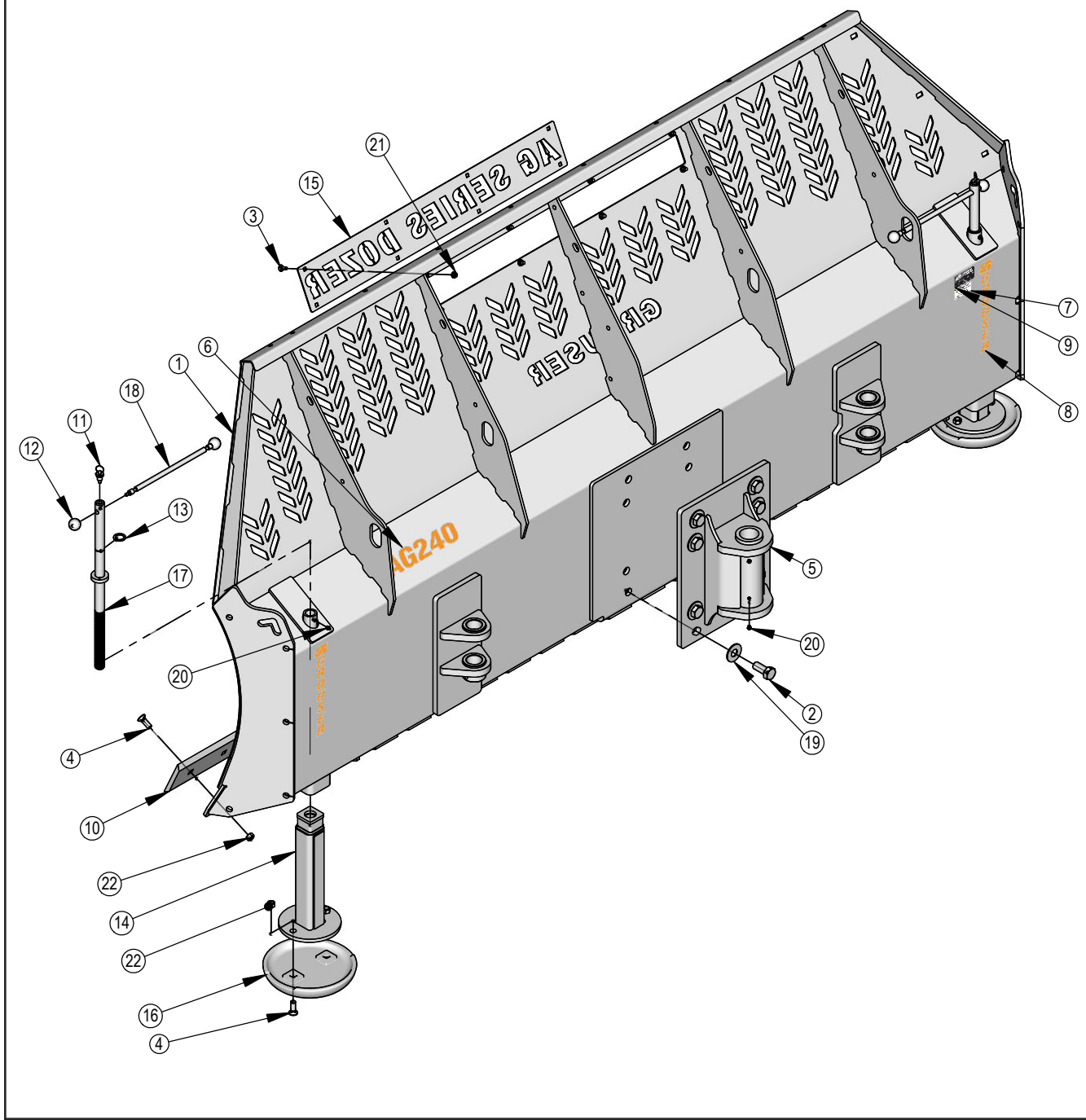

Hydraulic Angle-Hydraulic Tilt or Hydraulic Angle-No Tilt System

Item	Part No.	Description	Configuration	HAHT	HANT
				Qty.	Qty.
1	16-20040	5/16" x 2-1/2" Hex Bolt Gr 5 NC		3	2
2	16-20125	1/2" X 1-1/4" Hex Bolt Gr 5 NC		1	-
3	16-20134	1/2" x 3-1/2" Hex Bolt Gr 5 NC		4	4
4	16-20558	1" x 2" Hex Bolt Gr 8 NC		1	1
5	16-35C612	3/8" x 3/4" Flanged Bolt		2	-
6	18-19311-02-P-062	Hose Clamp		1	-
7	18-19312-02	Twin Cover Plate		2	-
8	19-13577	NR Pin Spacer Clevis End		2	-
9	19-40419	2.25 x 2.00 x 1.38 Spring Bushing		8	8
10	19-7774	1"x1" Spring Bushing		1	-
11	25-34342	Tappet Quick Coupler - Male		4	2
12	25-3453	Pioneer Dust Cap Tilt (Green)		2	-
13	25-3455	Pioneer Dust Cap Angle (Red)		2	2
14	26-34711	4 x 8 Cylinder W/ Cast Clevis Ends		1	-
15	26-34748	5 x 12 Cylinder W/ Tube Ends (2.0")		2	2
15A	26-34759	5 x 10 Cylinder W/ Tube Ends (2.0")		2	2
16	27-2409	Pinch Decal (Hand)		1	-
17	27-9503	Pinch Decal (Foot)		2	-
18	31-11699-8-8	JIC Union (2403-8-8)		2	2
19	31-34040	Straight JIC x O-Ring (6400-8-8)		2	2
20	31-34050	Straight Thread Elbow 90° JIC x O-Ring (6801-8-8)		2	-
21	31-34051	Straight Thread Elbow 90° JIC x O-Ring (6801-8-10)		8	6
22	31-34070	Run Tee JIC x O-Ring (6804-8-8-8)		2	2
23	31-34100	Swivel Nut Elbow 90° JIC (6500-8-8)		2	2
24	32-18400	Tilt Frame (2.0")		1	-
25	32-18410	Angle Frame (2.0")		1	1
26	34-12932	Cylinder Saddle		2	2
27	34-12933	Hose Clamp		2	2
28	34-13807	Spring, Hose Support		1	-
29	34-18888-GR	-12 Green - Spiral Band		2	-
30	34-18888-RD	-12 Red - Spiral Band		2	2
31	35-17260	240 Formed Steel Line		2	2
32	35-31010	25" x 3/8" -8 JIC/-8 JIC Hose w/ Cordura		2	2
33	35-31013	28" x 3/8" -8 JIC/-8 JIC Hose w/ Cordura		2	2
34	35-31022	39" x 3/8" -8 JIC/-8 JIC Hose w/ Cordura		2	2
35	35-31030	63" x 3/8" -8 JIC/-8 JIC Hose w/ Cordura		1	-
36	35-31032	69" x 3/8" -8 JIC/-8 JIC Hose w/ Cordura		1	-
37	43-13580	1" Clevis Bolt in Pin		2	-
38	43-16925	Angle Pin		1	1
39	43-18405	Cylinder Pin (2")		4	4
40	56-7772	Relief Valve		1	1
41	57-16928	3.50" OD x 1.06" ID Washer		1	1
42	57-20791	5/16" Fender Washer		1	-
43	57-20794	1/2" Fender Washer		1	-
44	58-9369	Grease Zerk 1/8" NPT Straight		4	4
45	58-9371	Grease Zerk 1/8" NPT 45°		2	2
46	70-20581	5/16" Hex Nut NC		1	-
47	70-20604	1/2" Hex Center Lock Nut NC		4	4

Item A: For Challenger 1000 & Fendt 1000 Tractors.
 See Page 13 for the tractor side hydraulics.
 See Page 21 for hydraulic schematic.

NOTE: When ordering cylinder seal kits, the part number on the cylinder is needed. The number is stamped on the base end of the cylinder opposite of the hydraulic ports.

No. On Cylinder	Part No.	Description
26-34748	49-12272	Seal Kit 5 x 12 Nitrided Rod
26-34711	49-12271	Seal Kit 4 x 8 Nitrided Rod, Clevis Ends

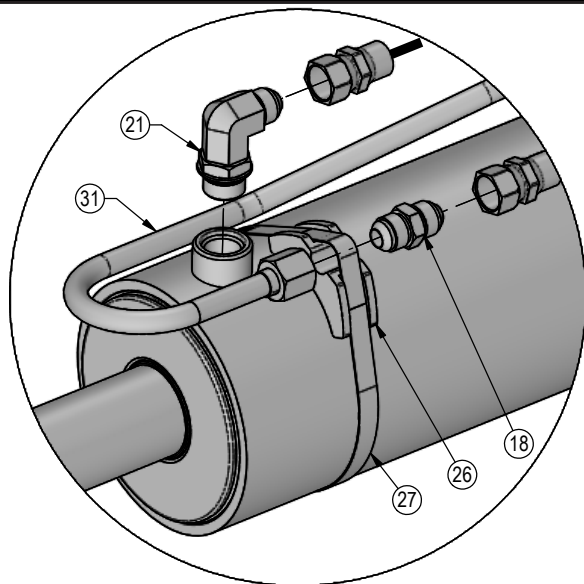

DETAIL B

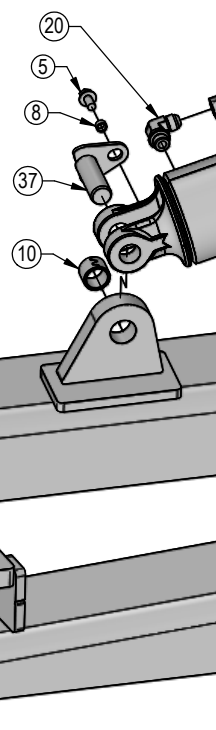
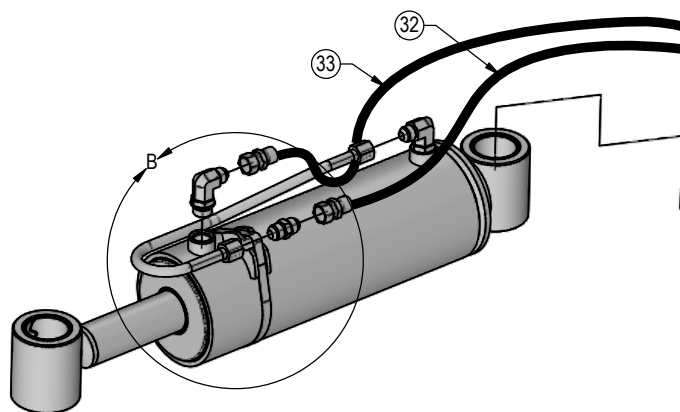

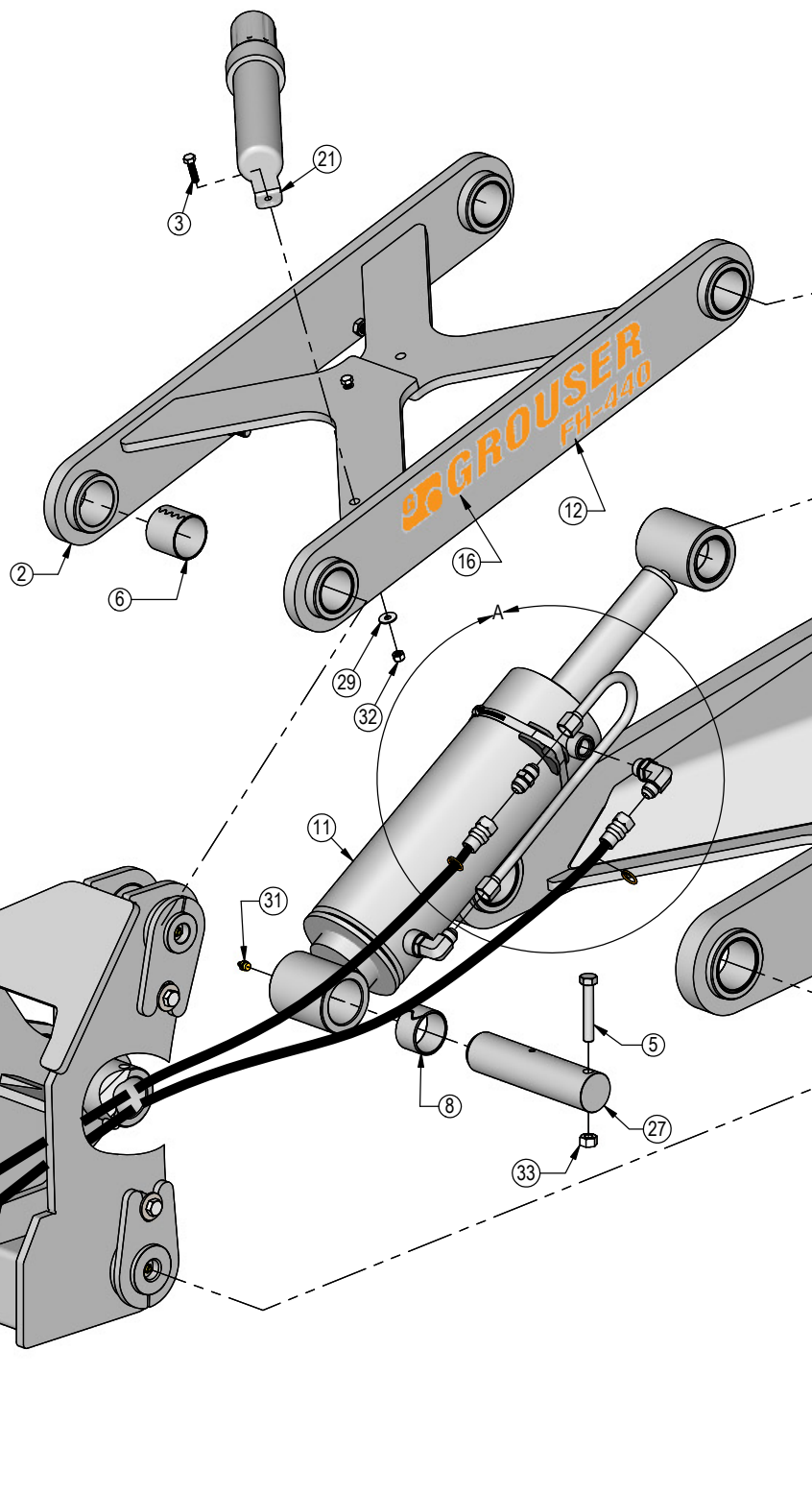
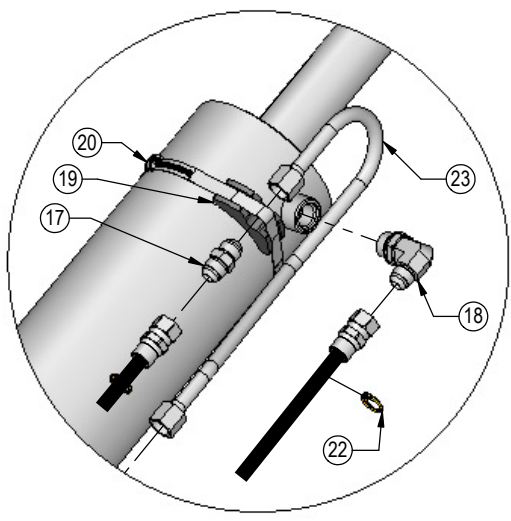

Item	Qty.	Part No.	Description
1	1	11-19000	FH-440 Lower Arm
2	1	11-19010	FH-440 Top Arm
3	2	16-20035	5/16" x 1-1/4" Hex Bolt Gr 5 NC
4	8	16-20125	1/2" x 1-1/4" Hex Bolt Gr 5 NC
5	2	16-20424	1/2" x 3-1/2" Hex Bolt Gr 8 NC
6	4	19-7954	2.25 x 2.00 x 2.00 Spring Bushing
7	4	19-16328	2.75 x 2.50 x 2.00 Spring Bushing
8	4	19-40419	2.25 x 2.00 x 1.38 Spring Bushing
9	2	25-34342	Tappet Quick Coupler Male - Poppet Style
10	2	25-3457	Pioneer Dust Cap Lift (Orange)
11	1	26-34748	5 x 12 Cylinder Tube Ends (2.0") (658378)
12	2	27-17263	FH-440 Decal
13	1	27-40425	Warning Decal - Extension
14	1	27-2409	Pinch Decal (Hand)

See Page 21 for hydraulic schematic.

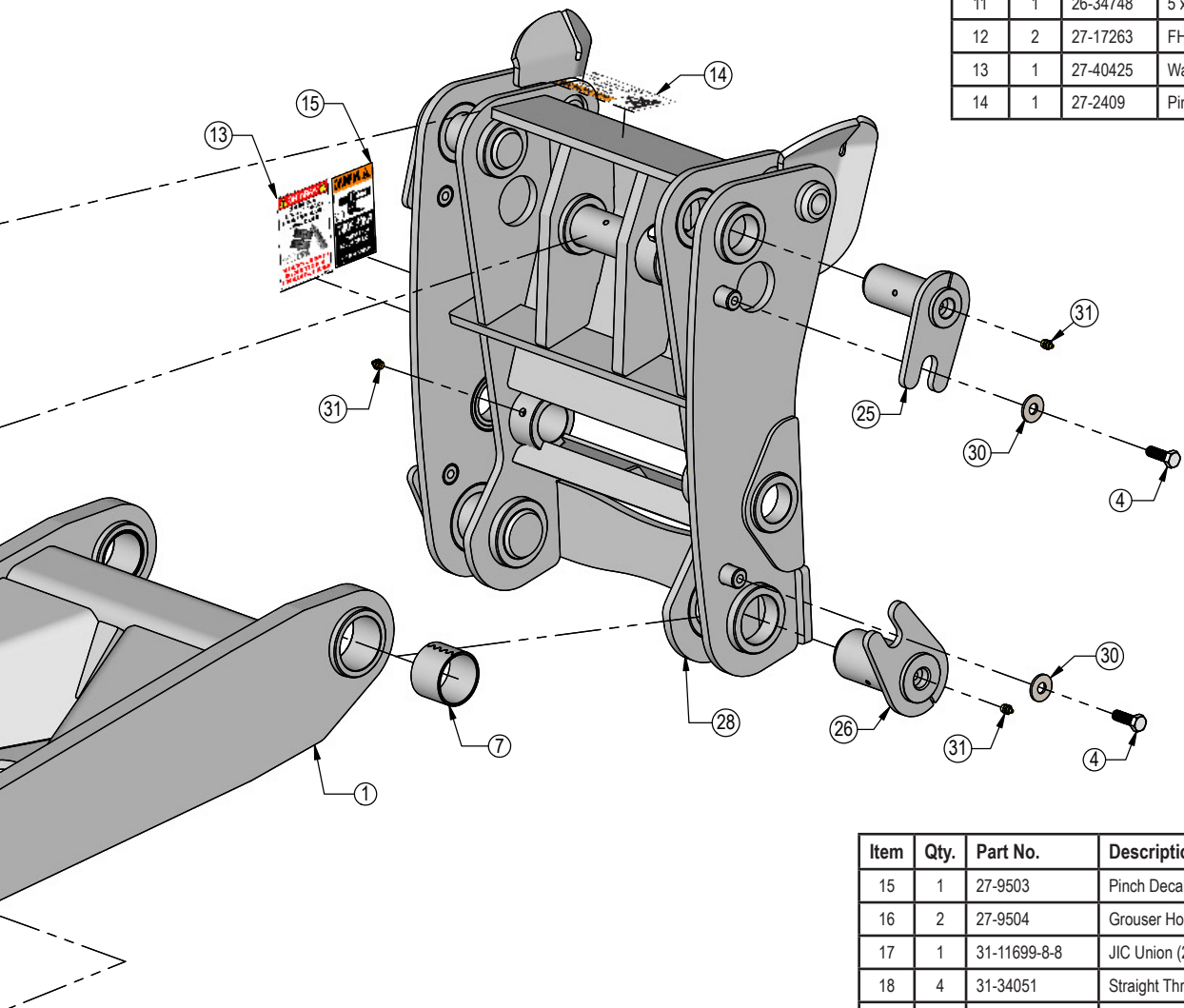

Item	Qty.	Part No.	Description
15	1	27-9503	Pinch Decal (Foot)
16	2	27-9504	Grouser Horizontal Decal
17	1	31-11699-8-8	JIC Union (2403-8-8)
18	4	31-34051	Straight Thread Elbow 90° JIC x O-Ring (6801-8-10)
19	1	34-12932	Cylinder Saddle (ZR518)
20	1	34-12933	Hose Clamp
21	1	34-14961	Manual Canister
22	4	34-18888-OR	-12 Spiral Band - Orange
23	1	35-17260	240 Formed Steel Line
24	2	35-17721-280-1	280" x 1/2" -8JIC/-8JIC Hose W/ 36" Cordura
25	4	43-16385	240 Upper Pin
26	4	43-16390	240 Lower Pin
27	2	43-18405	240 Cylinder Pin (2.0")
28	1	45-18300	240 Quick Attach (2.0")
29	2	57-20741	5/16" Flat Washer
30	8	57-20794	1/2" Fender Washer
31	12	58-9369	Grease Zerk 1/8" NPT Straight
32	2	70-20611	5/16" Nyloc Nut
33	2	70-20604	1/2" Hex Center Lock Nut NC

NOTE: When ordering cylinder seal kits, the part number on the cylinder is needed. The number is stamped on the base end of the cylinder opposite of the hydraulic ports.

No. On Cylinder	Part No.	Description
26-34748	49-12272	Seal Kit 5 x 12 - Nitrided Rod

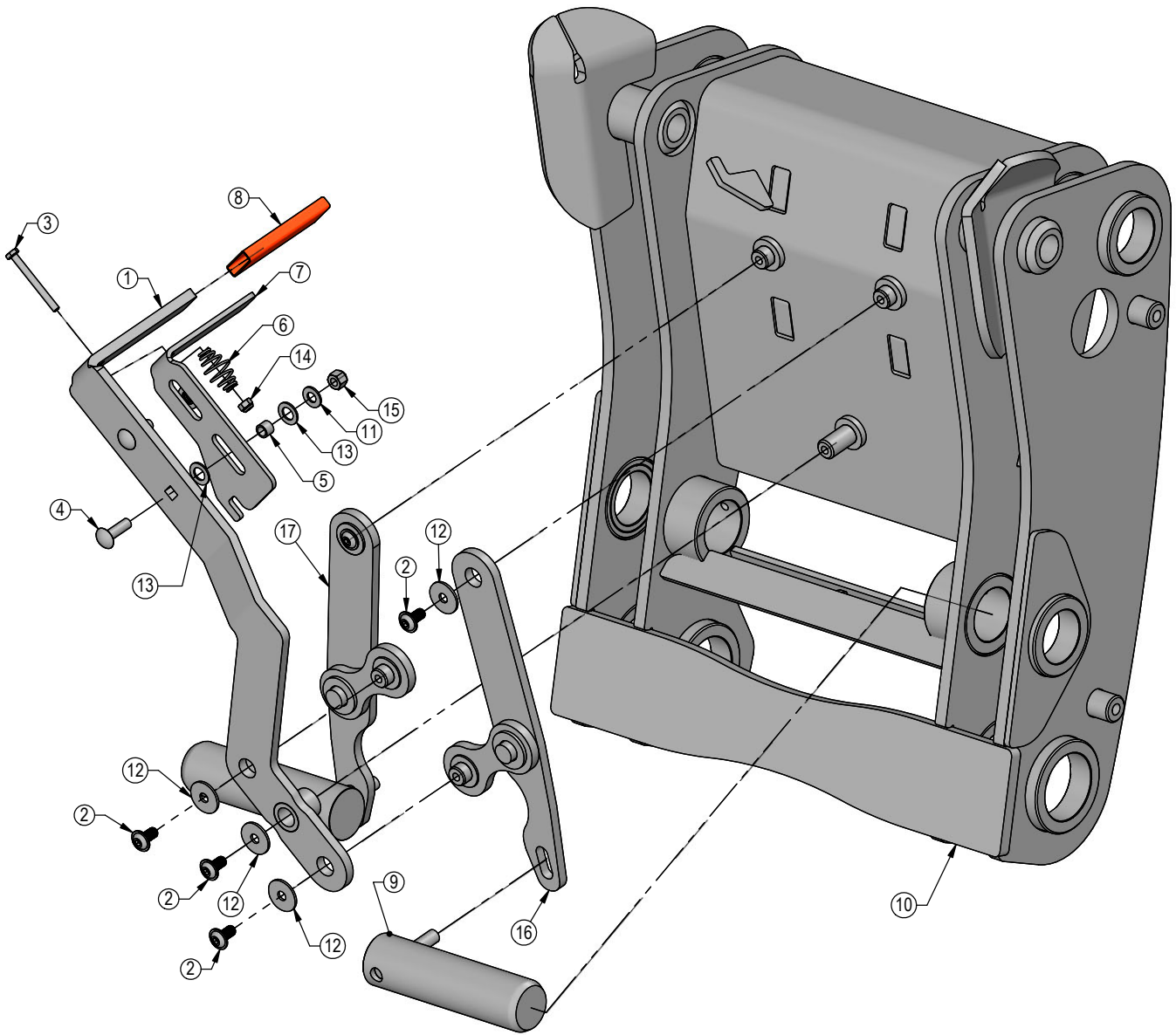

ITEM NO.	QTY.	PART NO.	DESCRIPTION
1	1	11-16918	Pin Pulling Arm Assembly
2	5	16-17266	3/8" x 3/4" Flange Button Socket Cap Bolt
3	1	16-20011	1/4" x 2-3/4" Hex Bolt Gr 5 NC
4	2	16-21065	3/8" x 1-1/4" Carriage Bolt Gr 5 NC
5	2	19-40440	.378" ID x .503" OD x .375" Spacer
6	1	34-17799	Latch Spring
7	1	39-16931	Latch
8	1	39-3072	Rubber Handle
9	2	43-40765	Pin, 240 Lock Out
10	1	45-18300	Quick Attach
11	2	57-20742	3/8" Flat Washer
12	5	57-20792	3/8" Fender Washer
13	4	57-40408	3/8" Flat Nylon Washer
14	1	70-20610	1/4" Nyloc Hex Nut Gr 5 NC
15	2	70-20612	3/8" Nyloc Hex Nut Gr 5 NC
16	1	75-16915-L	Link Assembly
17	1	75-16915-R	Link Assembly

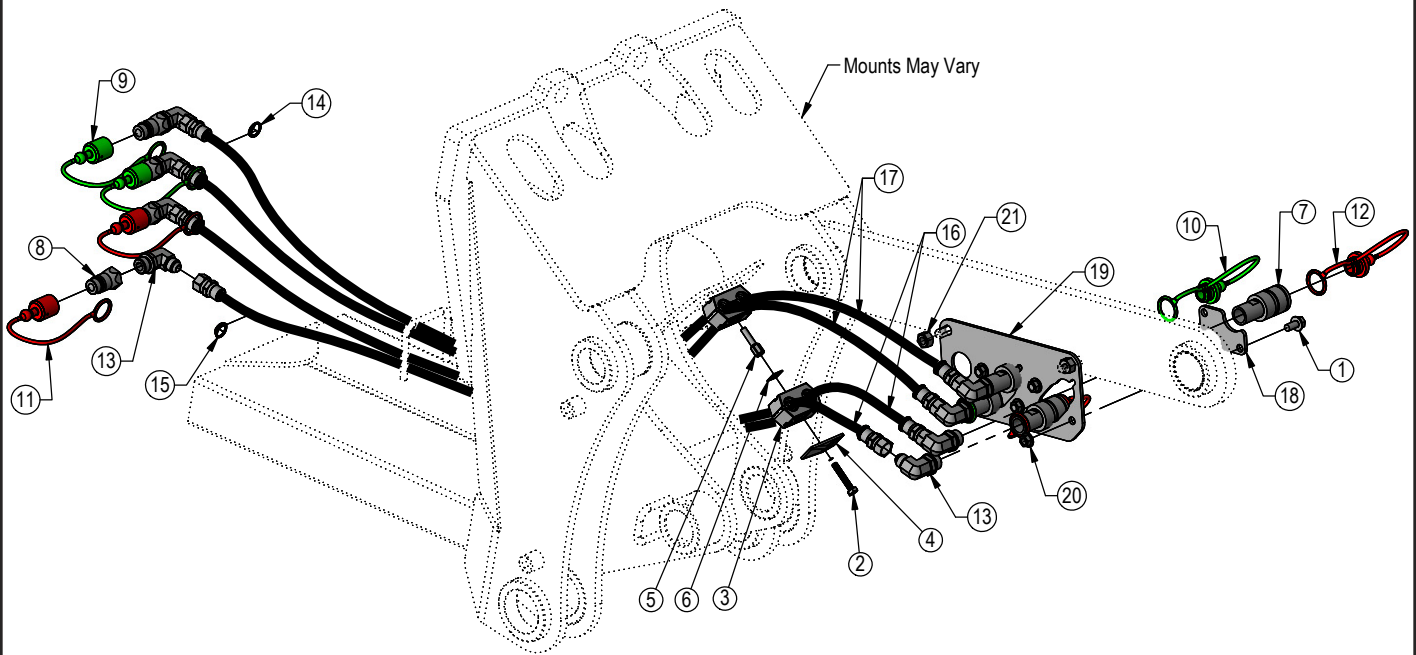

Some parts hidden for clarity
See Page 21 for hydraulic schematic.

Item	Part No.	Description	Configuration	HAHT	HANT
			Qty.	Qty.	Qty.
1	16-35C612	3/8" x 3/4" Flanged Bolt		4	2
2	16-20037	5/16" x 1-3/4 " Hex Bolt Gr 5 NC		1	1
3	18-19311-03-P-087	Hose Clamp (TS-CLH-03-P-087)		2	1
4	18-19312-03	Twin Cover Plate (TS-TCP-03-Z)		1	1
5	18-19313-03	Twin Stacking Bolt (TS-STB-03-Y-56H)		1	-
6	18-19314-02	Twin Safety Plate (TS-SAF-02-Y)		1	-
7	25-34321	Tappet Quick Coupler - Female		4	2
8	25-34342	Tappet Quick Coupler - Male		4	2
9	25-3453	Pioneer Dust Cap Tilt (Green)		2	-
10	25-3454	Pioneer Dust Plug Tilt (Green)		2	-
11	25-3455	Pioneer Dust Cap Angle (Red)		2	2
12	25-3456	Pioneer Dust Plug Angle (Red)		2	2
13	31-34051	Straight Thread Elbow 90° JIC x O-Ring (6801-8-10)		8	-
14	34-18888-GR	-12 Green - Spiral Band		4	-
15	34-18888-RD	-12 Red - Spiral Band		4	4
16	35-17722-280-1	280" (23.3') x 3/8" -8JIC/-8JIC Hose w/21" Cordura & Collar		2	2
17	35-17722-280-2	280" (23.3') x 3/8" -8JIC/-8JIC Hose w/18.5" Cordura & Collar		2	-
18	44-14734	Female Coupler Retainer		2	1
19	44-16236	Female Coupler Mount		1	1
20	70-20622	3/8" Flange Hex Nut		4	2
21	70-20604	1/2" Hex Center Lock Nut		2	2

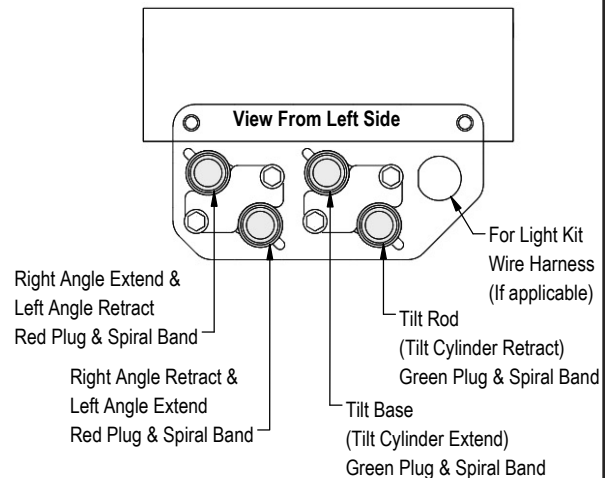

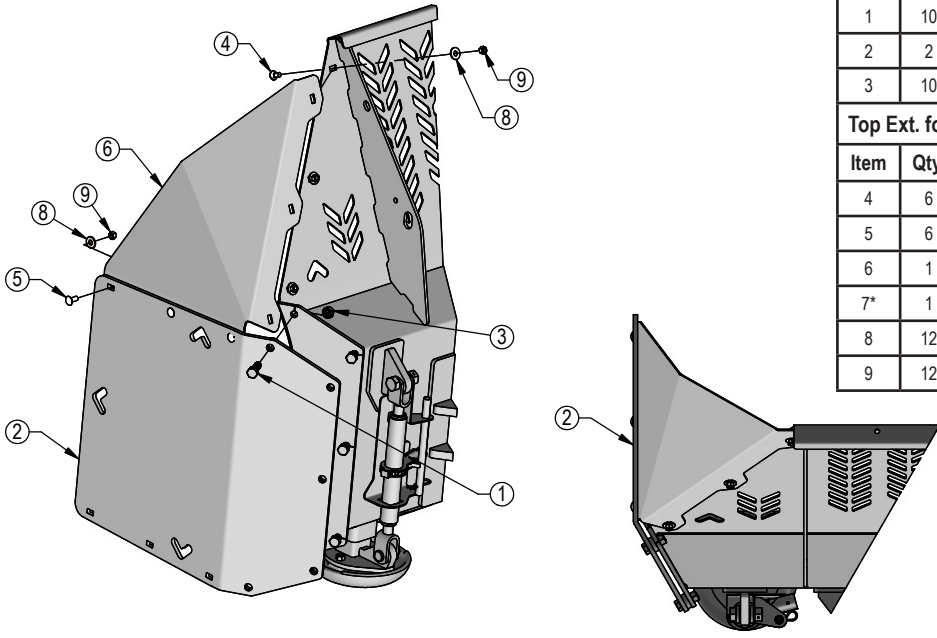

240 Box End Plates - 19350-K

Item	Qty.	Part No.	Description
1	10	16-20219	3/4" x 2-1/4" Hex Bolt Gr 5 NC
2	2	44-19350	240 - 1/2" Bent End Plates (Std Straight)
3	10	70-20607	3/4" Hex Center Lock Nut Gr 2 NC

Top Ext. for Box End Plates - 19351-K

Item	Qty.	Part No.	Description
4	6	16-21124	1/2" x 1" Carriage Bolt Gr 5 NC
5	6	16-21125	1/2" x 1-1/4" Carriage Bolt Gr 5 NC
6	1	44-19351-L	240 - Top Ext for Box End Plates - Left
7*	1	44-19351-R	240 - Top Ext for Box End Plates - Right
8	12	57-20744	1/2" Flat Washer
9	12	70-20604	1/2" Hex Center Lock Nut Gr 2 NC

* Parts Not Shown

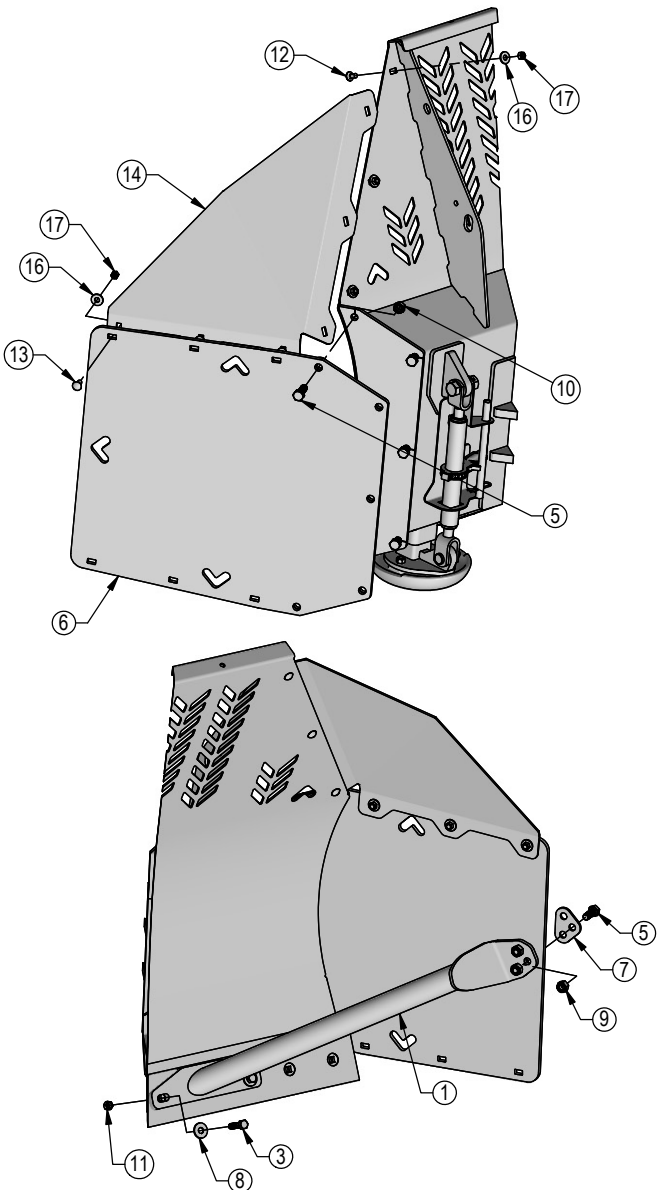

240 U-End Plates (U-End) - 19349-K

Item	Qty.	Part No.	Description
1	1	11-18640-L	240 - U-End Plate Brace - Left
2*	1	11-18640-R	240 - U-End Plate Brace - Right
3	4	16-20190	5/8" x 2 1/2" Hex Bolt Gr 5 NC
4	10	16-20219	3/4" x 2-1/4" Hex Bolt Gr 5 NC
5	6	16-20508	3/4" x 2" Hex Bolt Gr 8 NC
6	2	44-19349	240 - 1/2" Box End Plates (U-End)
7	2	44-18645	Lift Hook Washer
8	4	57-20816	5/8" Flat Washer Grade 8 (USS)
9	6	70-20597	3/4" Hex Nut Gr 8 NC
10	10	70-20607	3/4" Hex Center Lock Nut Gr 2 NC
11	4	70-20646	5/8" Hex Top Lock Nut Gr 5 NC

Top Ext. for U-End Plates - 19348-K

Item	Qty.	Part No.	Description
12	6	16-21124	1/2" x 1" Carriage Bolt Gr 5 NC
13	6	16-21125	1/2" x 1-1/4" Carriage Bolt Gr 5 NC
14	1	44-19348-L	240 - Top Ext for U-End Plates - Left
15*	1	44-19348-R	240 - Top Ext for U-End Plates - Right
16	12	57-20744	1/2" Flat Washer
17	12	70-20604	1/2" Hex Center Lock Nut Gr 2 NC

* Parts Not Shown

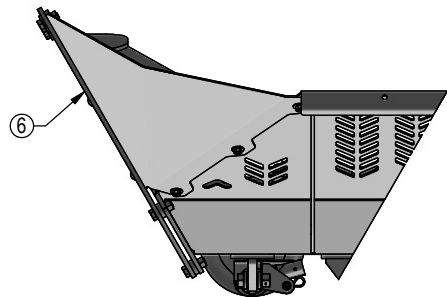

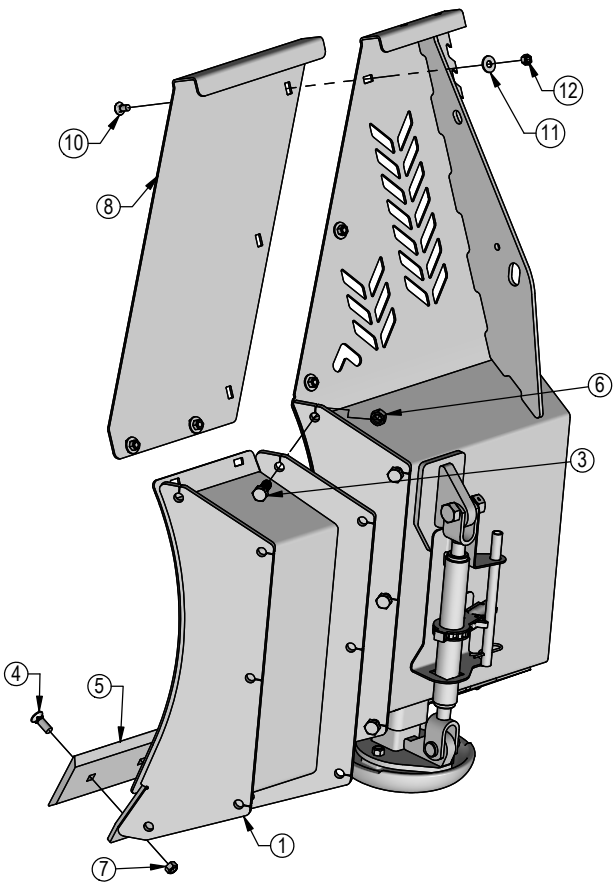

240 - 1' End Extension Kit - 17525-1-A			
Item	Qty.	Part No.	Description
1	1	15-17525-1-L	1' End Extension - Left
2*	1	15-17525-1-R	1' End Extension - Right
3	10	16-20218	3/4" x 2" Hex Bolt Gr 5 NC
4	4	16-21666	5/8" x 1-3/4" Plow Bolt Gr 5 NC
5	2	29-7950-1	1'- 5/8" x 6" Double Bevel Cutting Edge
6	10	70-20607	3/4" Hex Center Lock Nut Gr 2 NC
7	4	70-20646	5/8" Hex Top Lock Nut Gr 5 NC

240 - 1' End Extension Top Extension Kit - 19215-K			
Item	Qty.	Part No.	Description
8	1	15-19215-L	240 1' End Extension Top Extension - Left
9*	1	15-19215-R	240 1' End Extension Top Extension - Right
10	10	16-21124	1/2" x 1" Carriage Bolt Gr 5 NC
11	10	57-20744	1/2" Flat Washer
12	10	70-20604	1/2" Hex Center Lock Nut Gr 2 NC

240 - 2' End Extension Kit - 17525-2-A			
Item	Qty.	Part No.	Description
1*	1	15-17525-2-L	2' End Extension - Left
2*	1	15-17525-2-R	2' End Extension - Right
3	10	16-20218	3/4" x 2" Hex Bolt Gr 5 NC
4	8	16-21666	5/8" x 1-3/4" Plow Bolt Gr 5 NC
5*	2	29-7950-2	2'- 5/8" x 6" Double Bevel Cutting Edge
6	10	70-20607	3/4" Hex Center Lock Nut Gr 2 NC
7	8	70-20646	5/8" Hex Top Lock Nut Gr 5 NC

240 - 2' End Extension Top Extension Kit - 19216-K			
Item	Qty.	Part No.	Description
8*	1	15-19216-L	240 2' End Extension Top Extension - Left
9*	1	15-19216-R	240 2' End Extension Top Extension - Right
10	12	16-21124	1/2" x 1" Carriage Bolt Gr 5 NC
11	12	57-20744	1/2" Flat Washer
12	12	70-20604	1/2" Hex Center Lock Nut Gr 2 NC

* Parts Not Shown

NOTE: The FH-440 to 240 Extension is an option for tractors equipped with duals. The extension provides extra clearance between the tires and the blade system. Tire size and row spacing will determine if your system will require the extension.

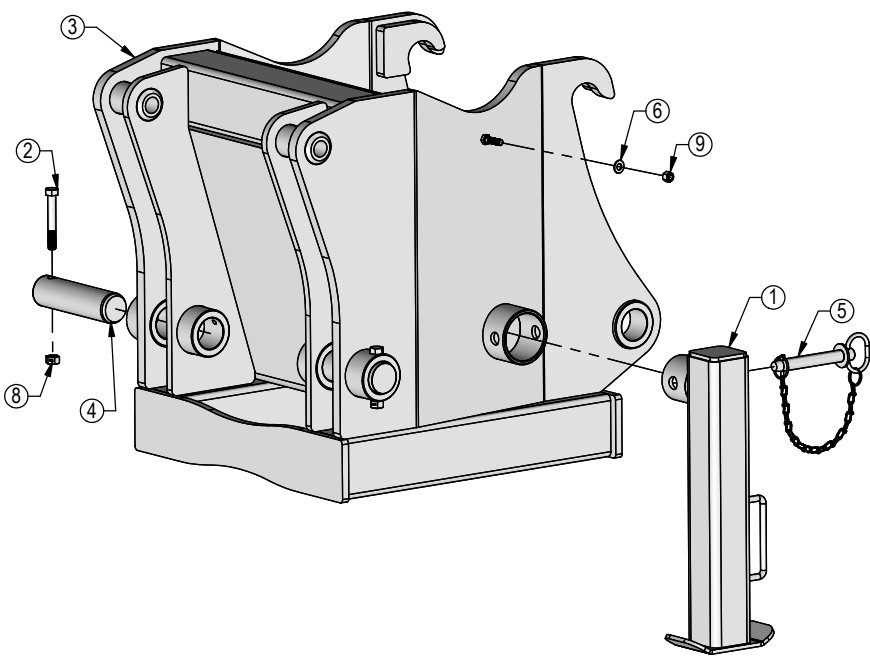

FH-440 to 240 Extension Assy - 40285-A			
Item	Qty.	Part No.	Description
1	1	11-40610R1	440 To 240 Adapter Stand
2	2	16-20134	1/2" X 3 1/2" Hex Bolt Gr 5 NC
3	1	32-40285R2	FH-440 to 240 Extension
4	2	43-16923R2	240 Pin Pulling Pin
5	1	43-40453	Hitch Pin with Chain
6	1	57-20742	3/8" Flat Washer
7*	1	59-16899-6	Heavy Duty Velcro Strap
8	2	70-20604	1/2" Hex Center Lock Nut Gr 2 NC
9	1	70-20612	3/8" Nyloc Nut

* Parts Not Shown

1' - 5/8" x 6" Cutting Edge w/ Hardware Kit - 7950-1K

Item	Qty.	Part No.	Description
1	2	16-21666	5/8" x 1-3/4" Plow Bolt Gr 5 NC
2	1	29-7950-1	1' - 5/8" x 6" Double Bevel Cutting Edge
3	2	70-20646	5/8" Hex Top Lock Nut Gr 5 NC

2' - 5/8" x 6" Cutting Edge w/ Hardware Kit - 7950-2K

Item	Qty.	Part No.	Description
1	4	16-21666	5/8" x 1-3/4" Plow Bolt Gr 5 NC
2	1	29-7950-2	2' - 5/8" x 6" Double Bevel Cutting Edge
3	2	70-20646	5/8" Hex Top Lock Nut Gr 5 NC

5' - 5/8" x 6" Cutting Edge w/ Hardware Kit - 7950-5K

Item	Qty.	Part No.	Description
1	10	16-21666	5/8" x 1-3/4" Plow Bolt Gr 5 NC
2	1	29-7950-5	5' - 5/8" x 6" Double Bevel Cutting Edge
3	10	70-20646	5/8" Hex Top Lock Nut Gr 5 NC

6' - 5/8" x 6" Cutting Edge w/ Hardware Kit - 7950-6K

Item	Qty.	Part No.	Description
1	12	16-21666	5/8" x 1-3/4" Plow Bolt Gr 5 NC
2	1	29-7950-6	6' - 5/8" x 6" Double Bevel Cutting Edge
3	12	70-20646	5/8" Hex Top Lock Nut Gr 5 NC

7' - 5/8" x 6" Cutting Edge w/ Hardware Kit - 7950-7K

Item	Qty.	Part No.	Description
1	12	16-21666	5/8" x 1-3/4" Plow Bolt Gr 5 NC
2	1	29-7950-7	7' - 5/8" x 6" Double Bevel Cutting Edge
3	14	70-20646	5/8" Hex Top Lock Nut Gr 5 NC

8' - 5/8" x 6" Cutting Edge w/ Hardware Kit - 7950-8K

Item	Qty.	Part No.	Description
1	16	16-21666	5/8" x 1-3/4" Plow Bolt Gr 5 NC
2	1	29-7950-1	1' - 5/8" x 6" Double Bevel Cutting Edge
3	16	70-20646	5/8" Hex Top Lock Nut Gr 5 NC

12" Round Mushroom Skid Shoe Kit (12'-16' Blades) - 15458-K

Item	Qty.	Part No.	Description
4	4	16-21666	5/8" x 1-3/4" Plow Bolt Gr 5 NC
5	2	50-15458	12" Round Mushroom Skid Shoe
6	4	70-20646	5/8" Hex Top Lock Nut Gr 5 NC

240 Skid Shoe Kit (10' Blades) - 8740-K

Item	Qty.	Part No.	Description
7	8	16-21218	3/4" x 2" Carriage Bolt Gr 5 NC
8	2	50-8740	2X0 Skid Shoe
9	8	57-20747	3/4" Flat Washer
10	8	70-20607	3/4" Hex Center Lock Nut Gr 2 NC

NOTE: Multiple cutting edge kits may be required.

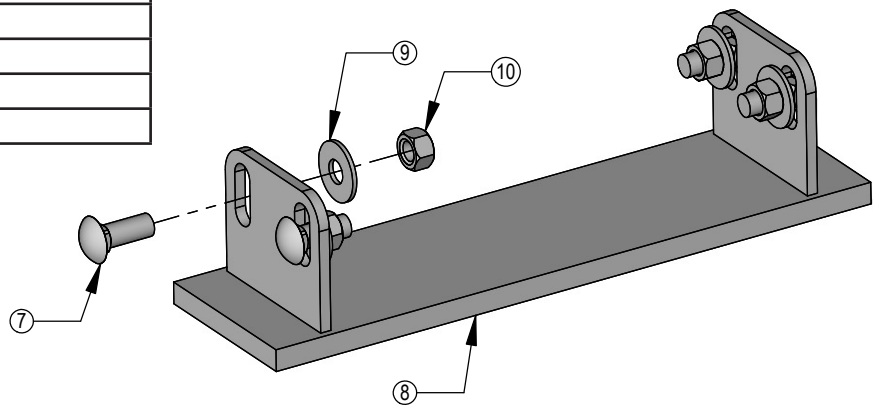
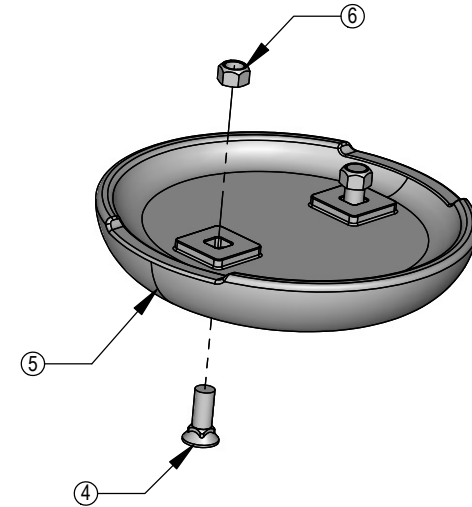
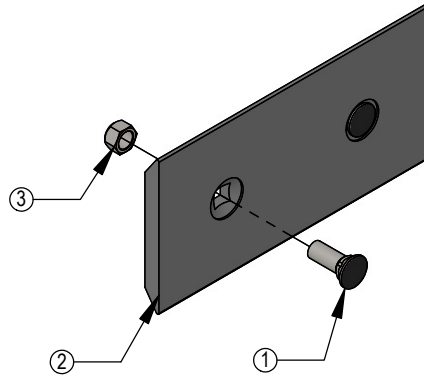

Some parts hidden for clarity

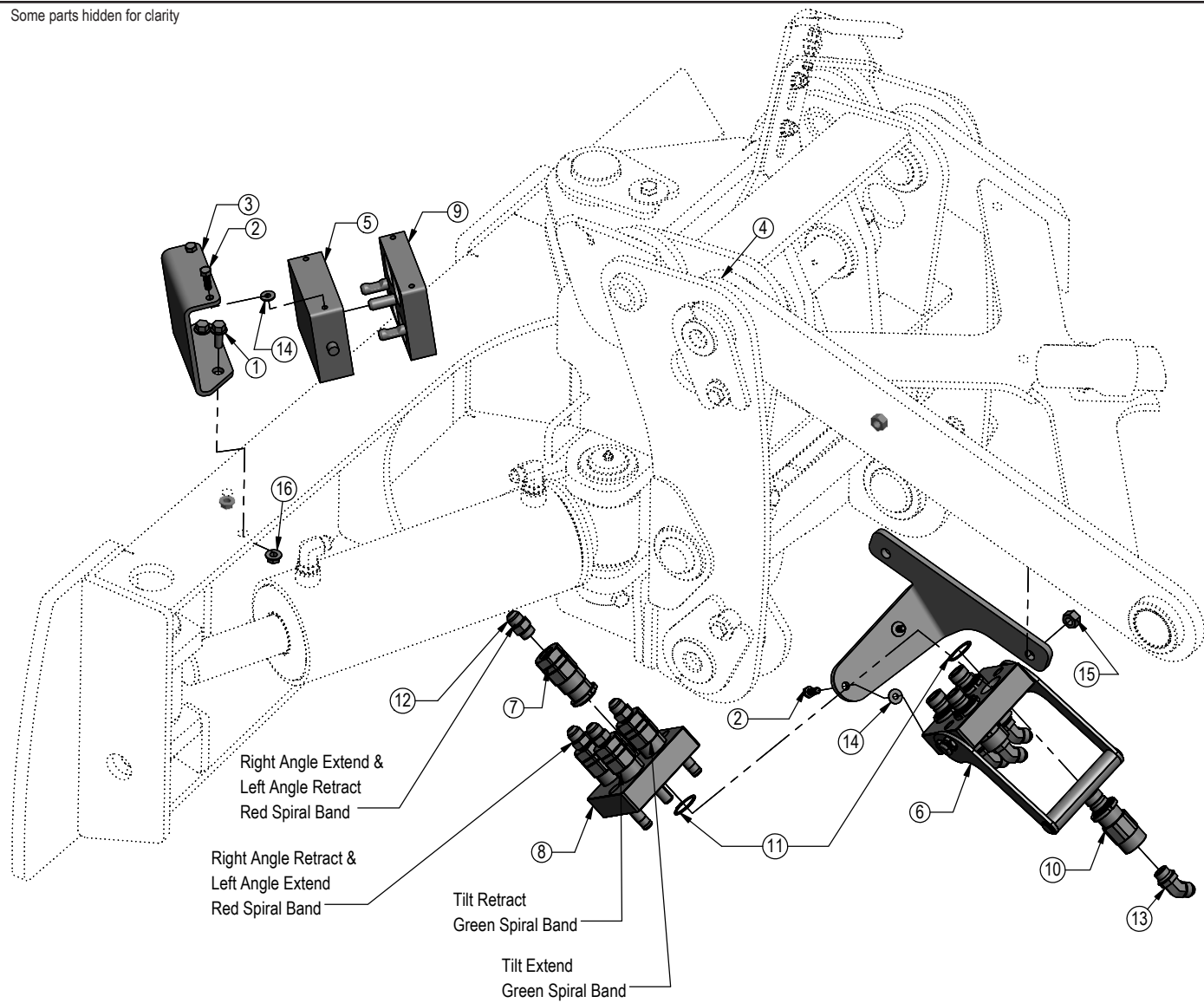

Item No.	Qty.	Part No.	Description
1	2	16-35C616	3/8" x 1" Flanged Bolt
2	4	16-812525	8mm x 1.25mm x 25mm Metric Hex Bolt Gr 10.9
3	1	18-19008	240 Quick Coupler - Parking Station Mount
4	1	18-19011	240 Quick Coupler Mount
5	1	25-18956	Multi-Coupling Plate - 4 Port Parking Station
6	1	25-19864	Multi-Coupling Plate - 4 Port Fixed
7	4	25-19865	Multi-Coupling Plate - Coupler - Female
8	1	25-19866	Multi-Coupling Plate - 4 Port Mobile
9	1	25-19867	Multi-Coupling Plate - 4 Port - Cap
10	4	25-19870	Multi-Coupling Plate - Coupler - Male
11	8	25-40407	Multi-Coupling Plate - Snap Ring
12	4	31-34040	Straight JIC x O-Ring (6400-08-08)
13	4	31-34150	Straight Thread Elbow 45° JIC x O-Ring (6802-8-8)
14	4	57-20740	1/4" Flat Washer
15	2	70-20604	1/2" Hex Center Lock Nut Gr 2 NC
16	2	70-20622	3/8" Flange Hex Nut Gr 5 NC

Notes:
 1. Follow the multi-coupler maintenance steps for connecting and disconnecting on pages 19-20.
 2. After any maintenance, verify that hoses are in their correct position during reinstallation.

Some parts hidden for clarity

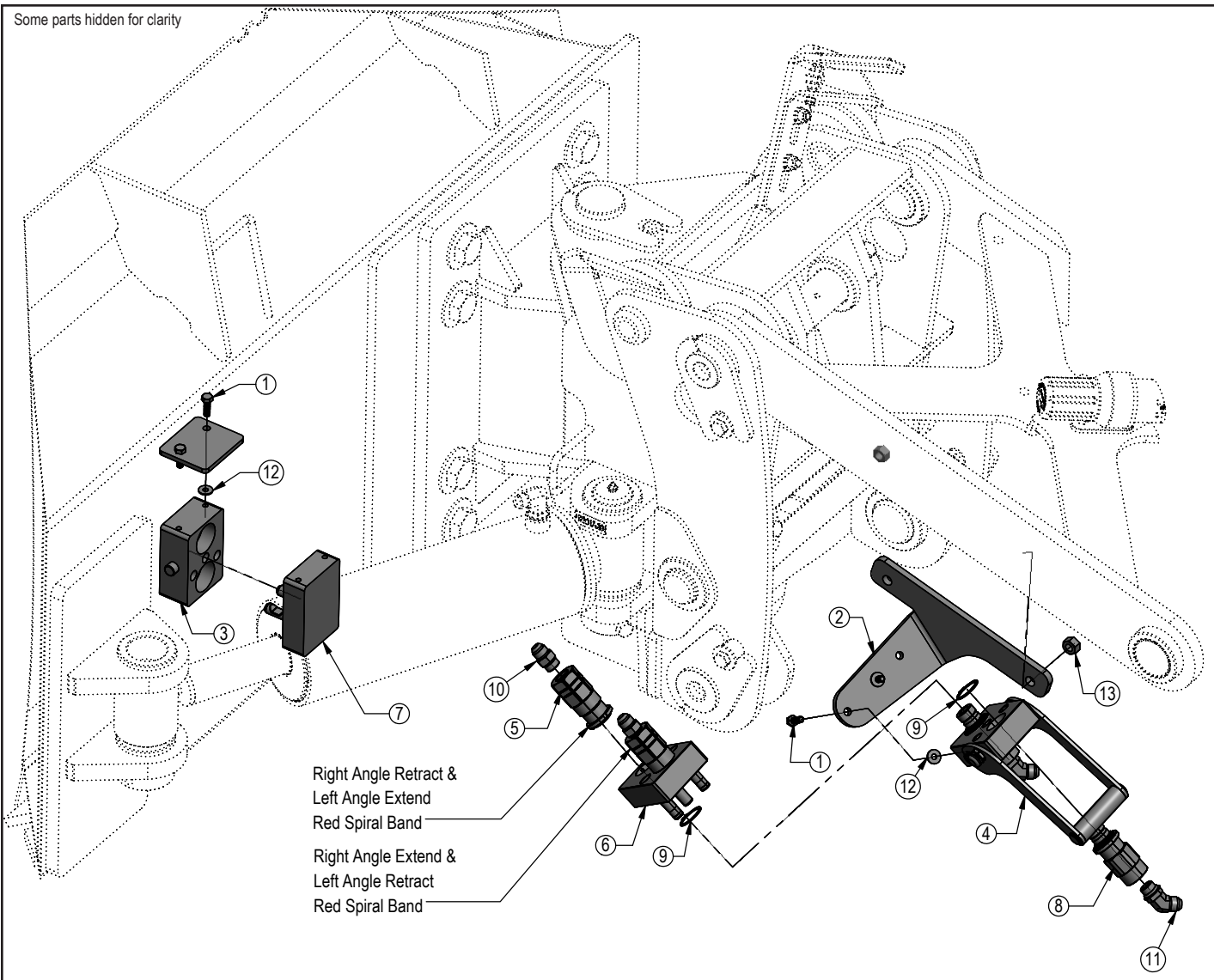

Right Angle Retract &
Left Angle Extend
Red Spiral Band

Right Angle Extend &
Left Angle Retract
Red Spiral Band

Notes:

1. Follow the multi-coupler maintenance steps for connecting and disconnecting on pages 19-20.
2. After any maintenance, verify that hoses are in their correct position during reinstallation.

Item No.	Qty.	Part No.	Description
1	4	16-812525	8mm x 1.25mm x 25mm Metric Hex Bolt Gr 10.9
2	1	18-19011	240 Quick Coupler Mount
3	1	25-19657	Multi-Coupling Plate - 2 Port Parking Station
4	1	25-19868	Multi-Coupling Plate - 2 Port Fixed
5	2	25-19865	Multi-Coupling Plate - Coupler - Female
6	1	25-19869	Multi-Coupling Plate - 2 Port Mobile
7	1	25-19871	Multi-Coupling Plate - 2 Port - Cap
8	2	25-19870	Multi-Coupling Plate - Coupler - Male
9	4	25-40407	Multi-Coupling Plate - Snap Ring
10	2	31-34040	Straight JIC x O-Ring (6400-08-08)
11	2	31-34150	Straight Thread Elbow 45° JIC x O-Ring (6802-8-8)
12	4	57-20740	1/4" Flat Washer
13	2	70-20604	1/2" Hex Center Lock Nut Gr 2 NC

Before Each Use:

1. Disconnect the mobile half from the parking station and the cap from the fixed half.
2. Check that there is no contamination (salt, sand, dirt, etc.):
 - A. On the pins.
 - B. Inside the cam.
 - C. In the locking mechanism area.
 - D. On the face of the plates and couplings.
3. In case of contamination, remove it with a cloth and/or compressed air.
4. Check that there is still a lubricant/anti-corrosion (grease or silicone - see Note 1):
 - A. On the pins.
 - B. Inside the cam.
 - C. In the locking mechanism area.
5. Connect the mobile and fixed halves together.

Fixed Half

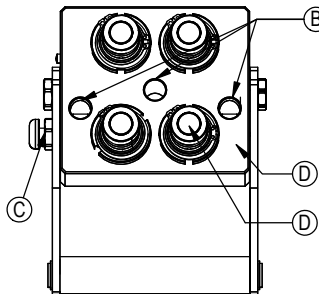

Mobile Half

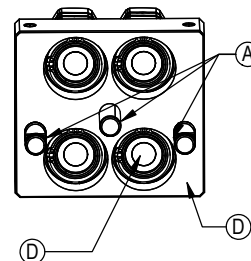

After Each Use:

1. Disconnect the mobile half from the fixed half.
2. Clean all contamination (salt, sand, dirt, etc.) from the following areas:
 - A. On the pins.
 - B. Inside the cam.
 - C. In the locking mechanism area.
 - D. On the face of the plates and couplings.

*Use a cloth or compressed air. It is advised to not use water to clean these surfaces
3. Apply a lubricant/anti-corrosion (grease or silicone - see Note 1):
 - A. On the pins.
 - B. Inside the cam.
 - C. In the locking mechanism area.
4. Connect the cap to the fixed half and the mobile half to the parking station.

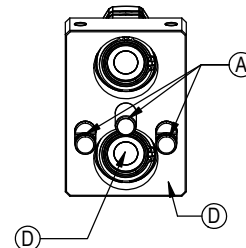
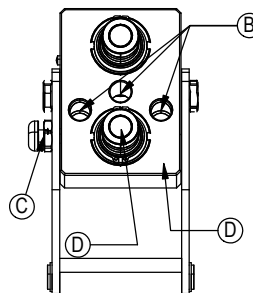

Note 1:

When sand and salt are present, or the plates under go a washdown, a heavy duty silicone spray lubricant should be used to replace grease from the factory. The lubricant should help protect from corrosion without collecting dust and contaminants, and will resist washing off when exposed to water.

Recommended Lubricant Brands:

Fluid Film (Aerosol or Non-Aerosol), LPS-2 Heavy Duty Lubricant, or CRC 3-36.

Cleaning The Male Interface Seal:



1. Make sure the coupling is securely fastened into the plate or place in a vice.



2. Using a blunt, non-marring tool, depress the valve face until the seal is exposed. Insert a bent metal wire between the valve face and the body of the coupling. Use caution not to damage or scratch the seal when inserting the wire.



3. Inspect the seal and interior surfaces for contamination.



4. In case of contamination, carefully wipe surfaces with a soft cloth, or use compressed air to blow the contamination out. Do Not press hard on the seal as contamination can scratch the seal surface.



5. Using a non-marring tool, depress the valve face and remove the metal wire. Release the valve to the flush position.

Cleaning The Female Bushing:



1. Make sure the coupling is securely fastened into the plate or place in a vice.



2. Using a non-marring tool, depress the outer ring to expose the bushing. There is no need to expose the valve seal, so stop pressing before the valve is opened.



3. Inspect the interior body and bushing surfaces for contamination.



4. In case of contamination, carefully wipe surfaces with a soft cloth, or use compressed air to blow the contamination out.



5. Release the outer ring so that it returns to the flush position.

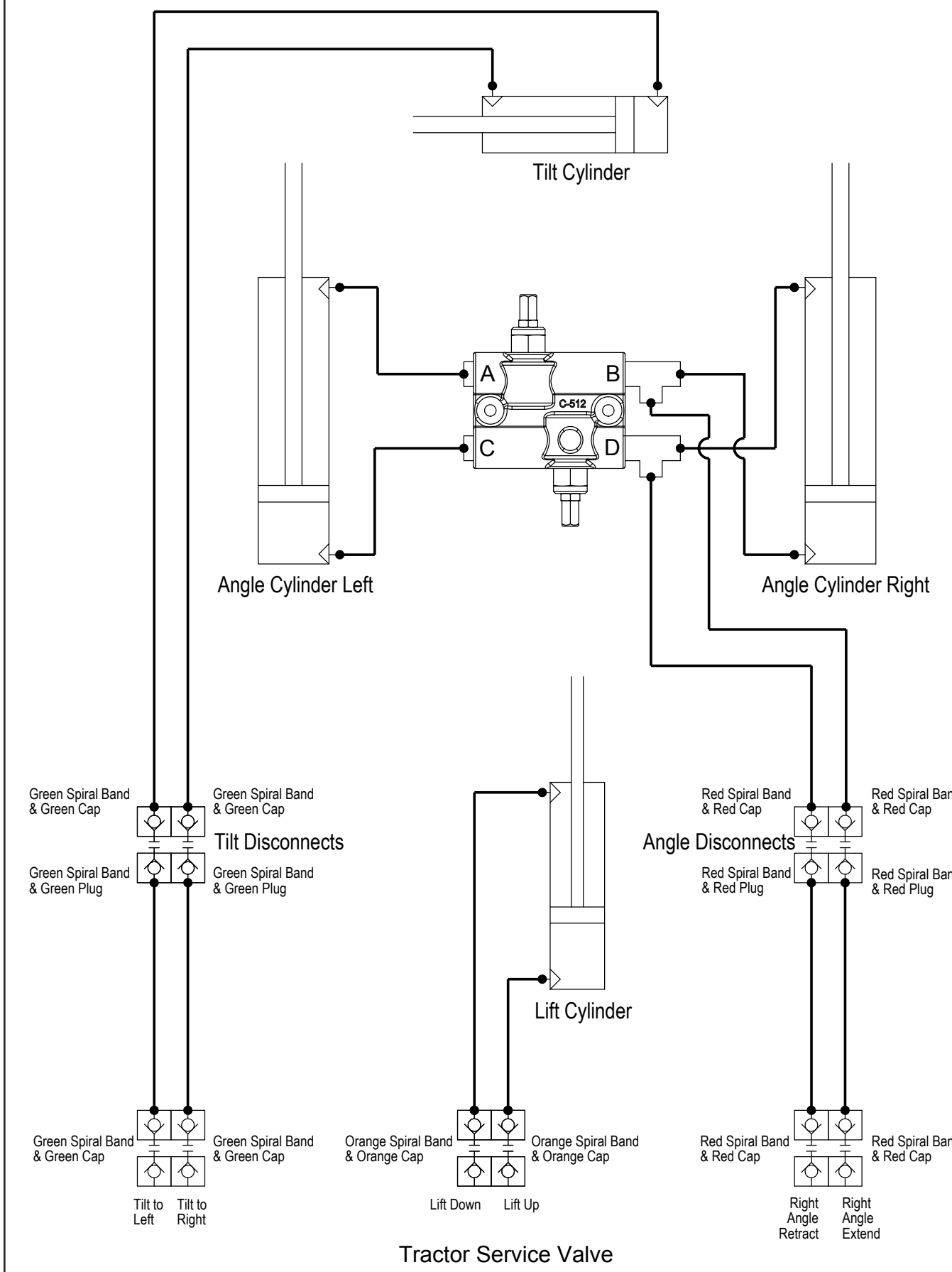

Contact Us

As always, if you have any questions about your AG240 Dozer and FH-440 Front Hitch or other products made by Grouser, feel free to contact us.

Grouser Products

755 2nd Ave NW - West Fargo, ND 58078

Phone: 1-701-282-7710

Fax: 1-701-282-8131

E-mail: info@grouser.com

Website: www.grouser.com

Improvements

Grouser Products Inc. is continually striving to improve its products. We reserve the right to change prices, specification, or equipment at any time without notice. We also reserve the right to make improvements or changes when it becomes practical and possible to do so without incurring any obligation to make changes or additions to the equipment sold previously.

Warranty

Grouser Products warrants to the original purchaser of each item that the product be free from defects in material and workmanship under normal use and service for a period of two years. If such equipment is found to be defective within two years, it is the obligation of Grouser Products under this warranty to repair or replace (exclusive of the cost of labor and transportation), any equipment or parts, in the judgment of Grouser Products to be defective in material or workmanship.

All equipment or parts claimed to be defective in material or workmanship must be made available for inspection at the place of business of a dealer authorized to handle the equipment covered by this warranty, or, upon request by Grouser Products, shipped to the Grouser Products factory in West Fargo, North Dakota. Grouser Products shall have no obligation to bear the cost of labor or transportation in connection with replacement or repair of any such defective parts in the setup process.

This warranty covers only defects in material and workmanship. It does not cover depreciation or damage caused by normal wear, accident, improper assembly, improper adjustments, improper maintenance including lack of proper lubrication, or improper use. Therefore, Grouser Products liability under this warranty shall not be effective or actionable unless the equipment is assembled, maintained and operated in accordance with the operating instructions accompanying the equipment. Grouser Products shall have no liability if the equipment has been altered or reworked without the written authorization of Grouser Products.

Grouser Products' parts, which are furnished under this warranty and properly installed, shall be warranted to the same extent as the original parts under this warranty if, and only if, such parts are found to be defective within the original warranty period covering the original equipment.

