



450 & 660 - Slant Top Owner's Manual & Parts Book

Purchase Date

Serial Number

Model Number

Tractor Model

Dealer

Contents

Description	Page
To The Owner & Maintenance _____	2
Safety Precautions & Torque Specifications _____	3
Skid Shoe and Tilt Plate Adjustment _____	4
Blade Assemblies _____	5
Hydraulic Angle System & 2-Lever Angle System Operating Instructions _____	6
Relief Valve Instructions _____	6-7
Hydraulic Angle - Hydraulic Tilt _____	8
Hydraulic Angle and Tilt Hose Routing _____	9
Hydraulic Angle - No Tilt _____	10
Hydraulic Angle - No Tilt Hose Routing _____	11
No Angle - Hydraulic Tilt w/ Tilt Frame & Hose Routing _____	12
No Angle - Hydraulic Tilt Hose Routing _____	12
Angle Hydraulic Components & Quick Attach _____	13
No Angle - No Tilt w/ Tilt Frame & Hydraulic Angle 2-Lever System _____	14
Lift System & Hydraulic Components _____	15-16
Wiring Harness and Electrical System _____	17
Hydraulic Schematic & 2-Lever Hydraulic Schematic _____	18-19
Contact Us, Improvements, & Warranty _____	20

To The Owner

This manual contains information concerning the operation, adjustment, and maintenance of the 450 and 660 blade assembly. You have purchased dependable, long lasting equipment, but only by proper care and operation can you expect to receive the performance and long service built into our products. Please have all operators read this manual carefully and keep the manual available for ready reference. If you have any questions or concerns, contact Grouser Products.

Maintenance

Due to the harsh environment many of our equipment operates in, the following tasks should be performed every 10 hours or less.

- Inspect all equipment before operation for existing or potential damages.
- Lubricate all joints with high quality grease.
- Inspect and tighten all bolts to torque specifications on page 3.
- Check replaceable cutting edge for wear ensuring there is enough material to prevent permanent damage to the blade.
- Make sure all non-rotating pins are secured properly.
- Check hydraulic cylinders and hoses for damage or leaks. For replacement parts, see pages 9, 11, 12, 13 or 16 for your specific system.
- Check skid shoes for wear and replace if necessary. For adjustment, see page 4.
- Inspect all tilt-ways for aggressive wear. See page 4 for tilt plate adjustment.

Safety Precautions

A careful operator is the best operator. Most accidents can be avoided by observing certain precautions. To help prevent accidents, read and take the following precautions before operating this equipment. In addition to these precautions, please follow all safety and operational instructions of your tractor manufacturer.

The Dozer:

1. The 450 and 660 Dozer should be operated only by those who are responsible and instructed to do so.
2. Read the owner's manual carefully before using this equipment. Lack of operating knowledge can lead to accidents.
3. Keep the dozer maintained in reliable and satisfactory condition to ensure your safety.
4. Make sure the area is clear of people before moving any equipment.
5. Do not modify or permit anyone else to modify or alter the equipment and its components without first consulting Grouser Products or a Grouser dealer.

Servicing the Dozer:

1. Read and follow all safety instructions provided by the tractor manufacturer.
2. Always use proper personal safety gear when performing maintenance on equipment.
3. Before servicing, relieve hydraulic pressure, stop engine and fully engage parking brake.
4. Escaping hydraulic fluid under pressure can penetrate skin causing serious injury. If fluid is injected into skin, obtain medical attention immediately.
 - DO NOT use your hand to check for leaks. Use a piece of cardboard or paper to search for leaks.
 - Stop the engine and relieve pressure before connecting or disconnecting lines.
 - Tighten all connections before starting the engine or pressurizing lines.

Storing the Dozer:

1. Thoroughly clean the dozer before storage. Use paint where necessary to prevent rust.
2. Check the dozer for worn or damaged parts. Install new parts as required.
3. Lubricate all pins and joints.

Torque Specifications

All bolts should be tightened to specifications set by the manufacturer or previously stated amounts. If neither of these can be found the following torque chart should be used.

Size	Torque (ft-lbs)			
	SAE Grade 5		SAE Grade 8	
	UNC	UNF	UNC	UNF
5/16	17	19	24	27
3/8	30	35	45	50
7/16	50	55	70	80
1/2	75	85	110	120
9/16	110	120	150	170
5/8	150	170	210	240
3/4	260	300	380	420
7/8	430	470	600	670
1	640	720	910	1020

Size	Torque (ft-lbs)	
	Grade 8.8	Grade 10.9
M18 x 2.50	202	284
M20 x 2.50	286	401
M22 x 2.50	388	547
M24 x 3.00	493	694

Skid Shoe and Tilt Plate Adjustment

Skid Shoe Adjustment:

1. Raise and secure blade to access skid shoe bolts and nuts.
2. Loosen nuts and set skid shoe depth by sliding the shoe back and forth in direction 'A' shown in Figure 1.
3. Once the depth is set, tighten bolts to 150 ft-lbs.
4. When skid shoes are worn down, replace with new skid shoes.

Tilt Plate Adjustment:

1. Remove bolts and tilt plates.

Note: Don't remove all of the bolts at the same time.

2. Add or remove washers as needed to adjust tilt-way clearance to have $1/16''$ - $1/8''$ of clearance in direction 'B' shown in Figure 1.
3. Once the tilt-way clearance is set, tighten bolts to 640 ft-lbs.

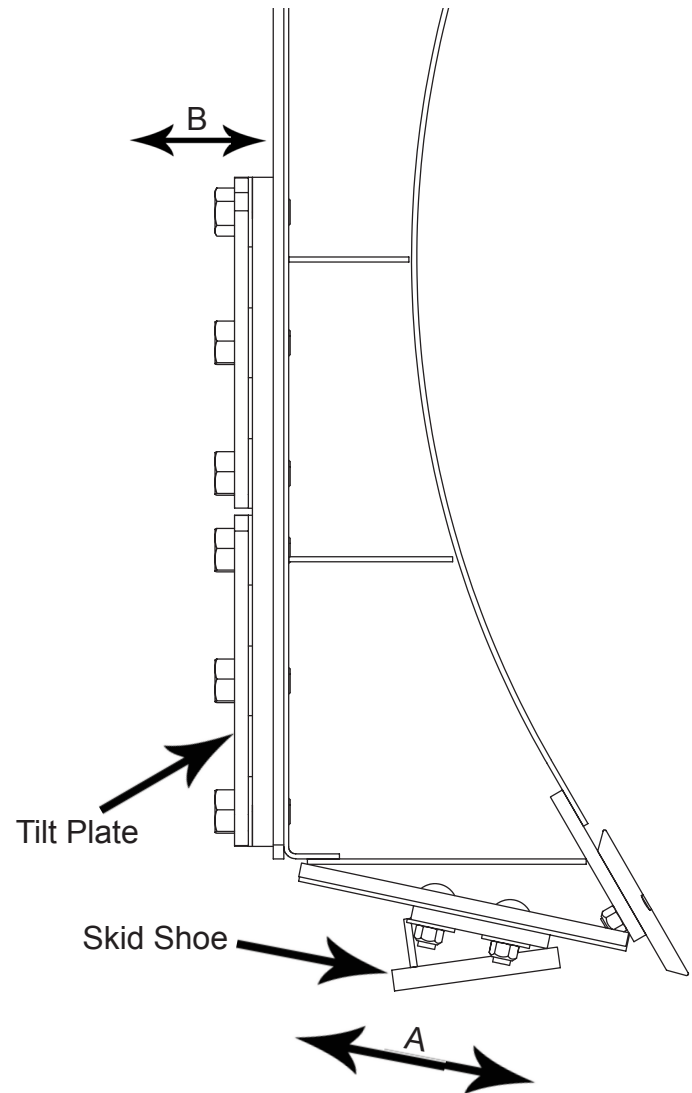

Figure 1

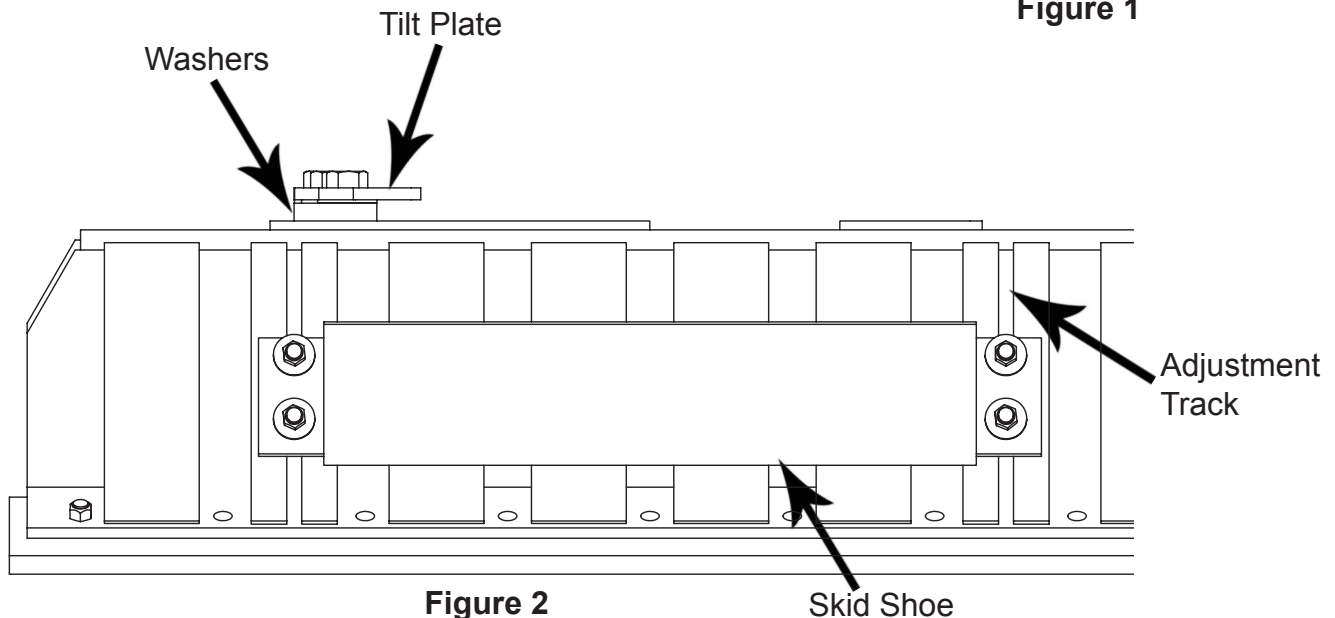
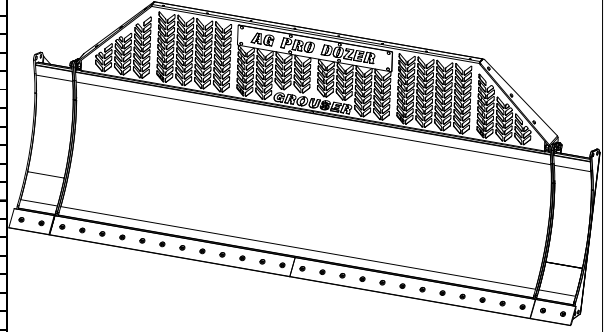

Figure 2

THE INFORMATION CONTAINED IN THIS DRAWING IS THE SOLE PROPERTY OF GROUSER PRODUCTS INC. ANY REPRODUCTION IN PART OR WHOLE WITHOUT THE WRITTEN PERMISSION OF GROUSER PRODUCTS INC. IS PROHIBITED.

Blade Assembly

Item No.	Part No.	Description	Blade Length				
			12'	14'	16'	18'	20'
			Qty.	Qty.	Qty.	Qty.	Qty.
1	15-13970-12	AG Pro Blade 12' - Slant Top	1				
1	15-13970-14	AG Pro Blade 14' - Slant Top		1			
1	15-13970-16	AG Pro Blade 16' - Slant Top			1		
1	15-13970-18	AG Pro Blade 18' - Slant Top				1	
1	15-13970-20	AG Pro Blade 20' - Slant Top					1
2	15-14730-12	12" x 24" Bolt on Top Extension - Slant Top	1				
2	15-14730-14	14" x 24" Bolt on Top Extension - Slant Top		1			
2	15-14730-16	16" x 24" Bolt on Top Extension - Slant Top			1		
2	15-14730-18	18" x 24" Bolt on Top Extension - Slant Top				1	
2	15-14730-20	20" x 24" Bolt on Top Extension - Slant Top					1
3	16-20538	7/8" x 2" Hex Bolt Gr 8 NC	14	14	18	18	22
4	16-20558	1" x 2" Hex Bolt Gr 8 NC	3	3	3	3	3
5	16-20562	1" x 3" Hex Bolt Gr 8 NC	12	12	12	12	12
6	16-21064	3/8" x 1" Carga Bolt Gr 5 NC	8	8	8	8	8
7	16-21188	5/8" x 2" Carga Bolt Gr 5 NC	8	8	8	8	8
8	16-21666	5/8" x 1-3/4" Plow Bolt Gr 5 NC	24	28	32	36	40
9	19-7774	1" x 1" Spring Bushing	2	2	2	2	2
10	29-7950-6	6" - 5/8" x 6" Double Bevel Cutting Edge	2			3	2
10	29-7950-7	7" - 5/8" x 6" Double Bevel Cutting Edge		2			
10	29-7950-8	8" - 5/8" x 6" Double Bevel Cutting Edge			2		1
11	44-3749	Backdrag Brace Plate	1	1	1	1	1
12A	44-14830	Custom Name Plate	1	1	1	1	1
12B	44-15150	AG Pro Name Plate	1	1	1	1	1
13	50-8725	Skid Shoe 33"	2	2	2	2	2
14	52-8204	Tilt Plate	4	4	4	4	4
15	57-20749	1" Flat Washer	12	12	12	12	12
16	57-20816	5/8" Flat Washer Grade 8 (USS)	8	8	8	8	8
17	57-20818	7/8" Flat Washer Heavy Duty Grade 8 (USS)	28	28	36	36	44
18	70-20598	7/8" Hex Nut Gr 8 NC	14	14	18	18	22
19	70-20646	5/8" Hex Top Lock Nut Gr 5 NC	32	36	40	44	48
20	70-20622	3/8" Flange Nut	8	8	8	8	8



Item No.	Part No.	Description	End Extension Length	
			1'	2'
			Qty.	Qty.
21	15-13990-1-L	Slant Top 1' End Extension cmb - Left	1	
22	15-13990-1-R	Slant Top 1' End Extension cmb - Right	1	
23	15-13990-2-L	Slant Top 2' End Extension cmb - Left		1
24	15-13990-2-R	Slant Top 2' End Extension cmb - Right		1
25	16-20540	7/8" x 2-1/2" Hex Bolt Gr 8 NC	12	12
26	16-20542	7/8" x 3" Hex Bolt Gr 8 NC	4	4
27	16-21666	5/8" x 1-3/4" Plow Bolt Gr 5 NC	4	8
28	29-7950-1	1" - 6" Cutting Edge	2	
29	29-7950-2	2" - 6" Cutting Edge		2
30	57-20816	5/8" Flat Washer Gr 8 (USS)	4	8
31	57-20818	7/8" Flat Washer Heavy Duty Gr 8 (USS)	20	20
32	70-20598	7/8" Hex Nut Gr 8 NC	16	16
33	70-20646	5/8" Hex Top Lock Nut Gr 5 NC	4	8

Item #A for Custom Name Plates and Item #B for AG Pro Name Plate



GROUSER PRODUCTS INC.

755 2nd Ave NW Phone 701.282.7710
West Fargo, ND 58078 Fax 701.282.8131
WWW.GROUSER.COM

TITLE:

Blade Assembly

Date:

3-27-2011

THE INFORMATION CONTAINED IN THIS DRAWING IS THE SOLE PROPERTY OF GROUSER PRODUCTS INC. ANY REPRODUCTION IN PART OR WHOLE WITHOUT THE WRITTEN PERMISSION OF GROUSER PRODUCTS INC. IS PROHIBITED.

Blade Assembly

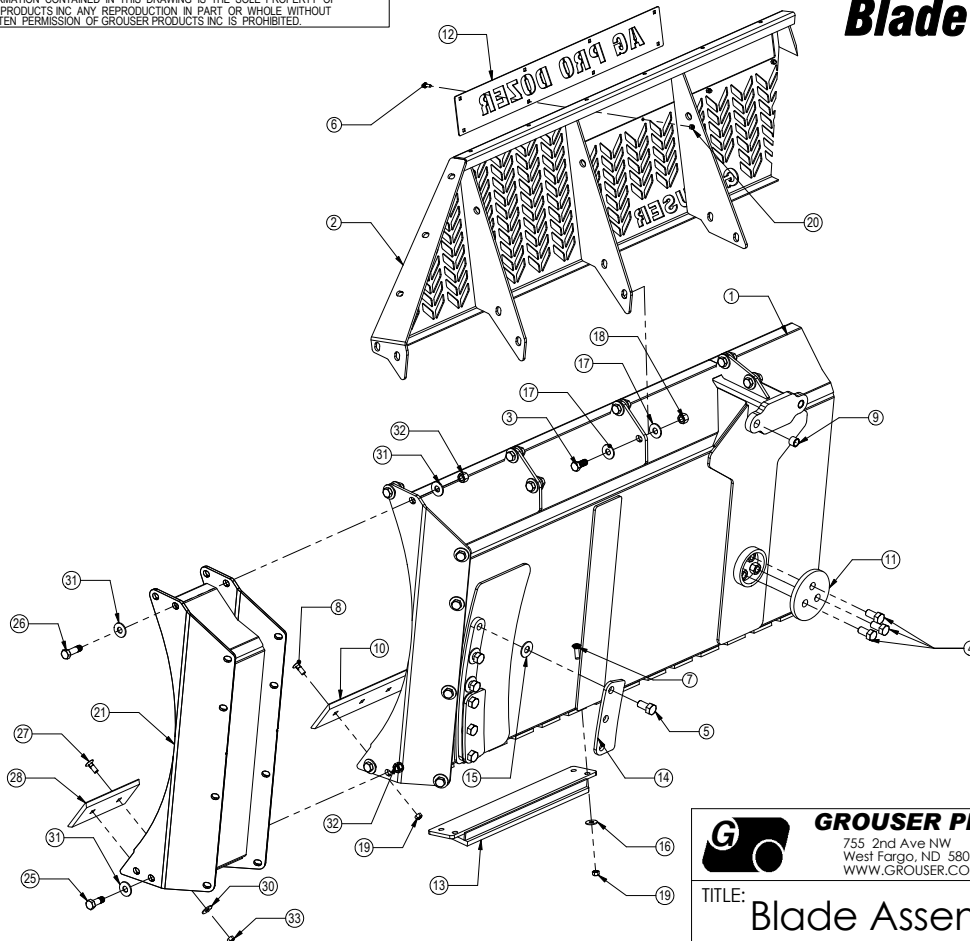

Item #22, 23 & 24 are not shown.



GROUSER PRODUCTS INC.

755 2nd Ave NW Phone 701.282.7710
West Fargo, ND 58078 Fax 701.282.8131
WWW.GROUSER.COM

TITLE:

Blade Assembly

Date:

3/27/2011

Hydraulic Instructions

Prior to operating the blade, bleed all air out of the hydraulic system. Start with the furthest location away from the remote until all air is out.

Hydraulic Angle System Operating Instructions

If your Grouser blade was purchased with the Hydraulic Angle Option, you will have the ability to angle the blade 30 degrees left or right. To achieve these angles, the two cylinders are designed to operate independently of each other through an electric diverter valve. To angle the blade to the left, actuate the tractor hydraulic control lever in the cab with the diverter valve un-powered. To angle the blade to the right, apply power to the diverter valve and then actuate the tractor hydraulic control lever.

2-Lever Angle System Operating Instructions

If your Grouser blade was purchased with the 2-Lever Hydraulic Angle Option, you will have the ability to angle the blade 30 degrees left or right. To achieve these angles, the two cylinders are designed to operate independently of each other with the use of 2 tractor hydraulic control levers and a safety relief valve. To angle the blade to the left or right, actuate the tractor hydraulic control lever corresponding to the left or right cylinder.

The safety relief valve allows the cylinder to retract if its internal pressure exceeds 2,000 psi. With this safety feature in place, when either cylinder reaches the end of its stroke, the safety relief valve will reroute pressure to the opposite cylinder causing it to extend. Refer to the Relief Valve Instructions below for possible adjustments.

Relief Valve Instructions

Set the safety relief valve at a higher pressure than tractor: To increase the pressure of the relief valve, install a 0-5,000 psi pressure gauge into the base end of right angle cylinder (see page 26). Loosen the jam nut on the safety valve and tighten the Allen screw 1/2 turn. Next, extend the right side cylinder out until the safety valve activates, while the safety valve is in function, record the pressure reading on the gauge. Continue to tighten the Allen screw in 1/2 turn increments and record the pressure until a high enough relief setting is obtained. **Do not exceed the 3,000-psi operating pressure of the cylinders.** Tighten the jam nut and remove the gauge.

Automatic lever release: In certain newer model tractors, the hydraulic control lever will automatically release and instantly stop oil flow once the end of the stroke is reached.

(Continued on next page)

CAUTION: Do not bypass the safety relief valve and plumb each cylinder to separate valves on the tractor.

To ensure proper use and life of equipment, it is recommended to have both cylinders closed for straight ahead dozing and only one cylinder partially or fully extended for angled dozing as shown in the diagrams below. **If the angle system is not used correctly, frame damage may occur.** Some damaged frames can be repaired, please contact Grouser Products for repair instructions if needed.

Please contact Grouser Products with any questions by:
Phone - 701-282-7710 or 800-747-6182; Fax - 701-282-8131

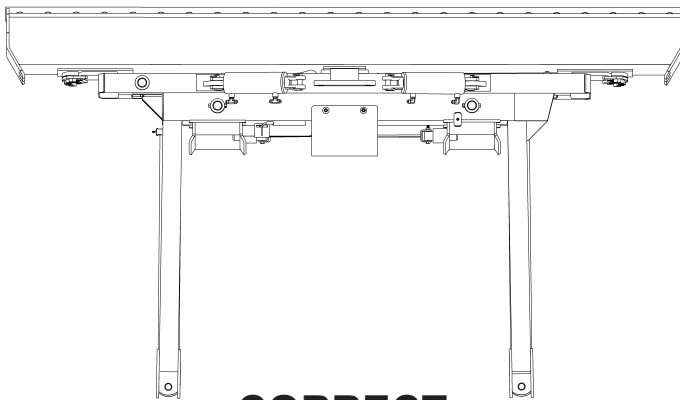

CORRECT

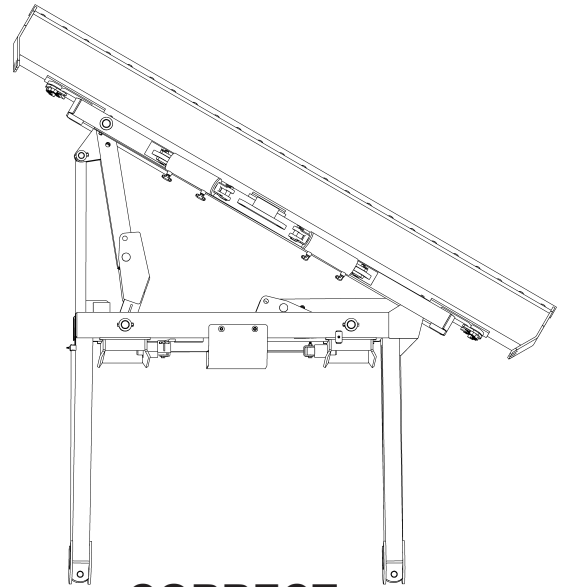

CORRECT
(Left or Right)

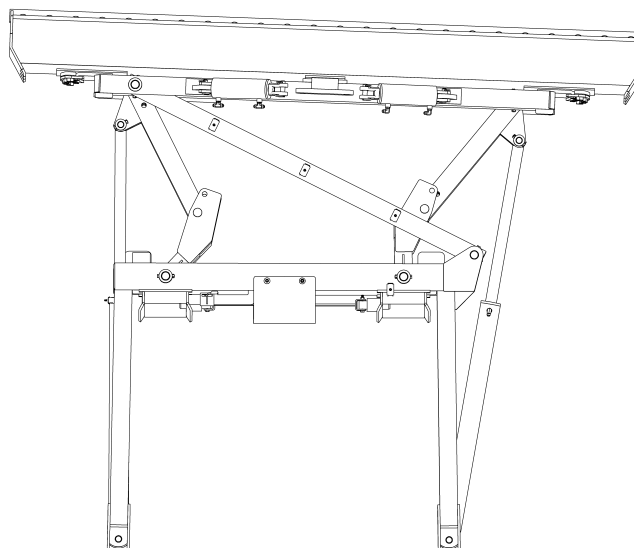

INCORRECT

THE INFORMATION CONTAINED IN THIS DRAWING IS THE SOLE PROPERTY OF GROUSER PRODUCTS INC. ANY REPRODUCTION IN PART OR WHOLE WITHOUT THE WRITTEN PERMISSION OF GROUSER PRODUCTS INC. IS PROHIBITED.

Hydraulic Angle - Hydraulic Tilt

To avoid frame damage, please read Hydraulic Angle System Operating Instructions (pages 6-7) before use!

Item No.	Qty.	Part No.	Description
1	1	11-5055	450, 660 & 760 Stabilizer Arm
2	1	11-8082	Angle Arm Right
3	1	11-9039	Angle Arm Left
4*	2	13-12294	Cast Rod End Clevis (490168)
5	5	16-20036	5/16" x 1-1/2" Hex Bolt Gr 5 NC
6	2	16-20043	5/16" x 3-1/4" Hex Bolt Gr 5 NC
7	4	16-20132	1/2" x 3" Hex Bolt Gr 5 NC
8	2	16-20424	1/2" x 3-1/2" Hex Bolt Gr 8 NC
9	3	16-20427	1/2" x 4-1/2" Hex Bolt Gr 8 NC
10	4	16-35C612	3/8" x 3/4" Flanged Bolt
11	8	18-3074	Hose Hold Down Clamp
12	8	18-3075	Hose Hold Down Clamp Plate
13	4	19-13577	NR Pin Spacer Clevis End
14	2	19-7774	1"x1" Spring Bushing (125100100)
15	2	26-34711	4x8 Cylinder w/ clevis ends (647134)
16	2	26-34725	4x43.5 Cylinder w/ tube ends -Top Port (647196)
17	1	32-14700	450, 660 & 760 Bolt on QA Angle Frame
18	1	32-5060	450, 660 Tilt Frame
19	4	43-13580	1" Clevis Bolt In Pin
20	1	43-8130	1-15/16" x 23-1/4" Pin (Tilt Frame / Angle Arm Right)
21	2	43-8131	1-15/16" x 31" Pin (Angle Frame/ Angle Arm)
22	1	43-8132	1-15/16" x 35-1/2" Pin (Tilt Frame / Angle Arm Left)
23	1	43-8133	1-15/16" x 7-1/8" Stabilizer Arm Pin
24	2	43-8134	1-1/2" x 8" Angle Cylinder Pin Base End
25	2	43-9352	1-1/2" x 7-1/2" Angle Cylinder Pin
26	2	58-9371	Grease Zerk 1/8" NPT 45°
27	6	58-9372	Grease Zerk 1/8" NPT 90°
28	1	70-20581	5/16" Hex Nut Gr 5 NC
29	9	70-20604	1/2" Hex Center Lock Nut Gr 5 NC

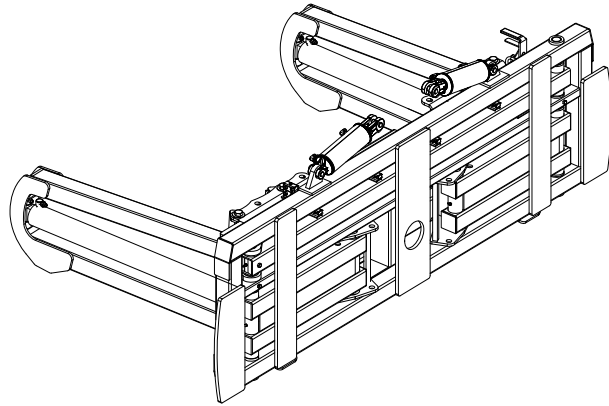

Refer to Page 9 & 13 for hydraulic components and hoses.
 Refer to Page 13 for Quick Attach Lever System Assembly.
 * Parts not shown.



GROUSER PRODUCTS INC.

755 2nd Ave NW Phone 701.282.7710
 West Fargo, ND 58078 Fax 701.282.8131
 WWW.GROUSER.COM

TITLE:
Hydraulic Angle - Hydraulic Tilt

Date:
2-15-2011

THE INFORMATION CONTAINED IN THIS DRAWING IS THE SOLE PROPERTY OF GROUSER PRODUCTS INC. ANY REPRODUCTION IN PART OR WHOLE WITHOUT THE WRITTEN PERMISSION OF GROUSER PRODUCTS INC. IS PROHIBITED.

Hydraulic Angle - Hydraulic Tilt

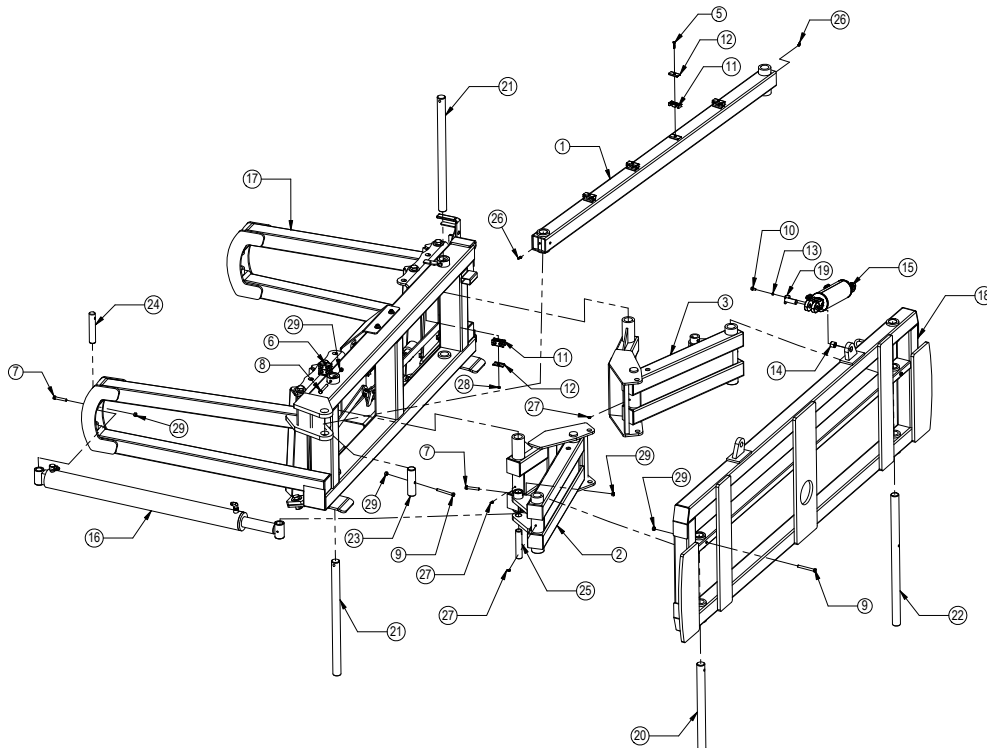

GROUSER PRODUCTS INC.

755 2nd Ave NW Phone 701.282.7710
 West Fargo, ND 58078 Fax 701.282.8131
 WWW.GROUSER.COM

TITLE:
Hydraulic Angle - Hydraulic Tilt

Date:
2-15-2011

THE INFORMATION CONTAINED IN THIS DRAWING IS THE SOLE PROPERTY OF GROUSER PRODUCTS INC. ANY REPRODUCTION IN PART OR WHOLE WITHOUT THE WRITTEN PERMISSION OF GROUSER PRODUCTS INC. IS PROHIBITED.

Hydraulic Angle and Tilt Hose Routing

Item No.	Qty.	Part No.	Description
1	7	16-20036	5/16" x 1-1/2" Hex Bolt Gr 5 NC
2	1	18-20043	5/16" x 3-1/4" Hex Bolt Gr 5 NC
3	8	18-3074	Hose Hold Down Clamp
4	9	18-3075	Hose Hold Down Clamp Plate
5	2	18-8973	Coupler Mounting Bracket (5006-4)
6	4	25-34321	Tappet Quick Coupler Female (8250-16)
7	8	25-34322	Tappet Quick Coupler Male (8010-16)
8*	4	25-3453	Pioneer Dust Cap Tilt (Green)
9*	2	25-3454	Pioneer Dust Plug Tilt (Green)
10*	4	25-3455	Pioneer Dust Cap Angle (Red)
11*	2	25-3456	Pioneer Dust Plug Angle (Red)
12	2	26-34711	4x8 Cylinder w/ clevis ends (647134)
13	2	26-34725	4x43.5 Cylinder w/ tube ends - Top Port (647196)
14*	1	31-13332	-8 SAE Breather Fitting
15	7	31-34040	Straight JIC x O-Ring (6400-8-8)
16	5	31-34050	Straight Thread Elbow 90° JIC x O-Ring (6801-8-8)
17	12	31-34051	Straight Thread Elbow 90° JIC x O-Ring (6801-08-10)
18	2	31-34060	Branch Tee JIC x O-Ring (6803-8-8-8)
19	1	31-34100	Swivel Nut Elbow 90° JIC (6500-8-8)
20	2	35-30022	39" x 3/8" -8JIC/-8JIC Hose (R16)
21	2	35-30121	35" x 1/2" -8JIC/-8JIC Hose (R16)
22	2	35-30134	75" x 1/2" -8JIC/-8JIC Hose (R16)
23	2	35-30145	108" x 1/2" -8JIC/-8JIC Hose (R16)
24	1	35-30149	156" x 1/2" -8JIC/-8JIC Hose (R16)
25	1	35-30150	160" x 1/2" -8JIC/-8JIC Hose (R16)
26	4	35-30162	390" x 1/2" -8JIC/-8JIC Hose (R16)
27	1	56-13305	Hydraulic Valve
28	2	57-20744	1/2" Flat Washer
29*	1	69-13351	Wire Harness - Valve To Disconnect
30*	1	69-1531	Wire Harness - Disconnect to Tractor
31*	1	70-20581	5/16" Hex Nut Gr 5 NC
32	2	70-20604	1/2" Hex Center Lock Nut Gr 5 NC

* Parts not shown.

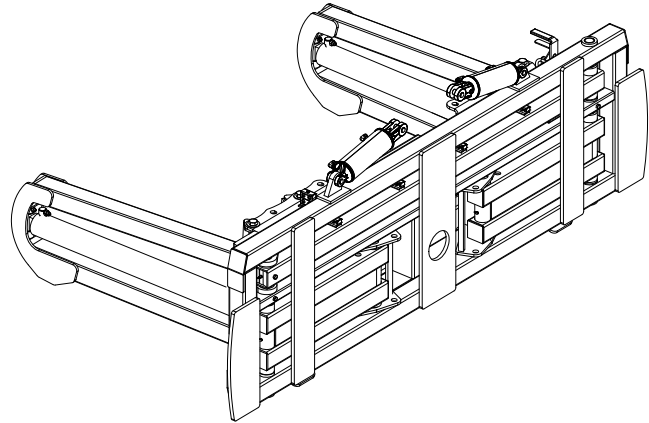

NOTE: When ordering cylinder seal kits, the part number on the cylinder is needed. The number is stamped on the base end of the cylinder opposite of the hydraulic ports.

No. On Cylinder	Part No.	Description
26-34711	49-12271	Seal Kit 4x8 (647135) Nitrided Rod, Clevis Ends
C40-158A	49-1534	Seal Kit 4x2 (SKC40-158A) Nitrided Rod, Clevis Ends
26-34725	49-12274	Seal Kit 4" x 43.5" (647210) Nitrided Rod
C40-179A10	49-1536	Seal Kit 4x2-1/2 (SKC40-163A) Nitrided Rod, Tube Ends



GROUSER PRODUCTS INC.

755 2nd Ave NW Phone 701.282.7710
West Fargo, ND 58078 Fax 701.282.8131
WWW.GROUSER.COM

TITLE: Hydraulic Angle and Tilt
Hose Routing

Date:
2-21-2011

THE INFORMATION CONTAINED IN THIS DRAWING IS THE SOLE PROPERTY OF GROUSER PRODUCTS INC. ANY REPRODUCTION IN PART OR WHOLE WITHOUT THE WRITTEN PERMISSION OF GROUSER PRODUCTS INC. IS PROHIBITED.

Hydraulic Angle and Tilt Hose Routing

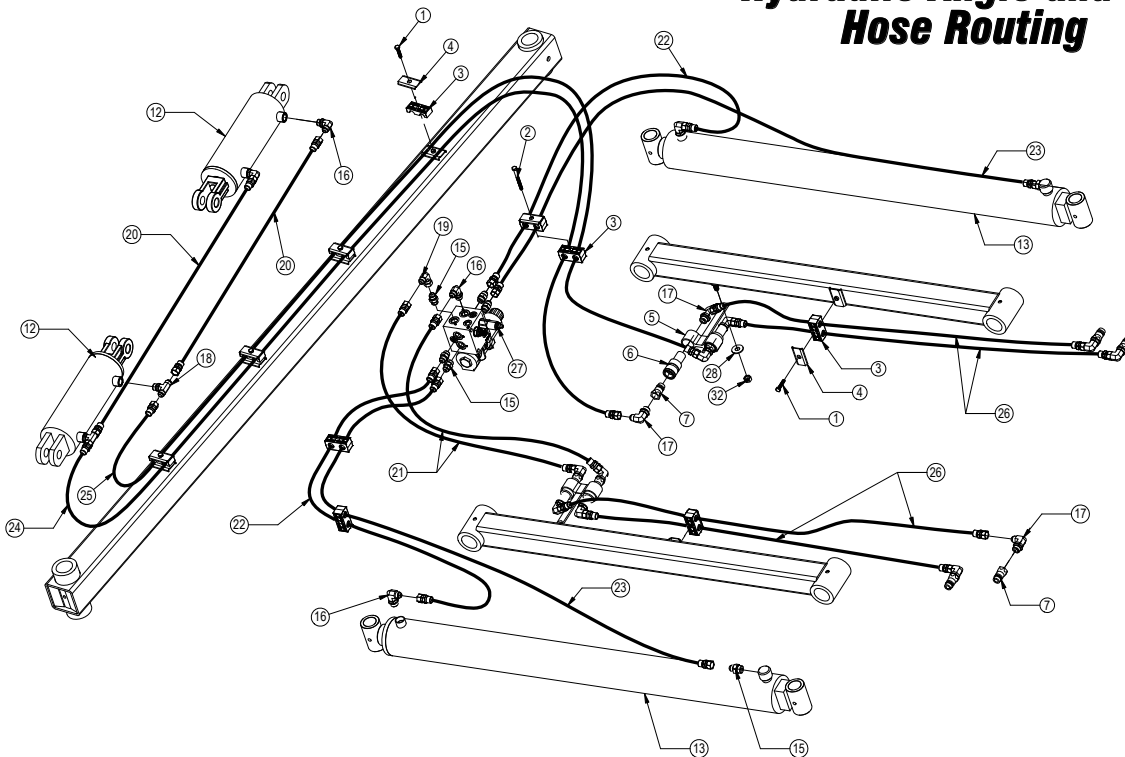

Hoses are not drawn to scale.



GROUSER PRODUCTS INC.

755 2nd Ave NW Phone 701.282.7710
West Fargo, ND 58078 Fax 701.282.8131
WWW.GROUSER.COM

TITLE: Hydraulic Angle and Tilt
Hose Routing

Date:
2-21-2011

THE INFORMATION CONTAINED IN THIS DRAWING IS THE SOLE PROPERTY OF GROUSER PRODUCTS INC. ANY REPRODUCTION IN PART OR WHOLE WITHOUT THE WRITTEN PERMISSION OF GROUSER PRODUCTS INC. IS PROHIBITED.

Hydraulic Angle - No Tilt

To avoid frame damage, please read Hydraulic Angle System Operating Instructions (pages 6-7) before use!

Item No.	Qty.	Part No.	Description
1	1	11-5055	450, 660 & 760 Stabilizer Arm
2	1	11-8082	Angle Arm Right
3	1	11-9039	Angle Arm Left
4	1	14-9366	Non Tilt Bar
5	3	16-20036	5/16" x 1-1/2" Hex Bolt Gr 5 NC
6	4	16-20132	1/2" x 3" Hex Bolt Gr 5 NC
7	2	16-20424	1/2" x 3-1/2" Hex Bolt Gr 8 NC
8	3	16-20427	1/2" x 4-1/2" Hex Bolt Gr 8 NC
9	2	16-20564	1" x 3-1/2" Hex Bolt Gr 8 NC
10	4	18-3074	Hose Hold Down Clamp
11	4	18-3075	Hose Hold Down Clamp Plate
12	2	19-7774	1"x1" Spring Bushing (125100100)
13	2	26-34725	4x43.5 Cylinder w/ tube ends - Top Port (647196)
14	1	32-14700	450, 660 & 760 Bolt on QA Angle Frame
15	1	32-14760	450, 660 & 760 Tilt Frame
16	1	43-8130	1-15/16" x 23-1/4" Pin (Tilt Frame / Angle Arm Right)
17	2	43-8131	1-15/16" x 31" Pin (Angle Frame / Angle Arm)
18	1	43-8132	1-15/16" x 35-1/2" Pin (Tilt Frame / Angle Arm Left)
19	1	43-8133	1-15/16" x 7-1/8" Stabilizer Arm Pin
20	2	43-8134	1-1/2" x 8" Angle Cylinder Pin Base End
21	2	43-9352	1-1/2" x 7-1/2" Angle Cylinder Pin
22	4	57-20749	1" Flat Washer
23	2	58-9371	Grease Zerk 1/8" NPT 45°
24	6	58-9372	Grease Zerk 1/8" NPT 90°
25	1	70-20581	5/16" Hex Nut Gr 5 NC
26	9	70-20604	1/2" Hex Center Lock Nut Gr 5 NC
27	2	70-20609	1" Hex Center Lock Nut Gr 5 NC

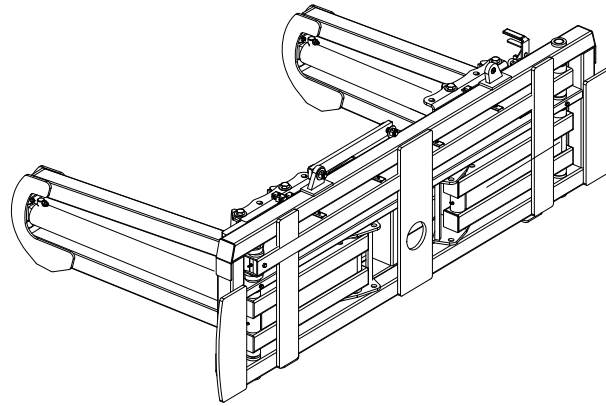

Refer to Page 11 and 13 for hydraulic components and hoses.

Refer to Page 13 for Quick Attach Lever System Assembly.

GROUSER PRODUCTS INC.
 755 2nd Ave NW Phone 701.282.7710
 West Fargo, ND 58078 Fax 701.282.8131
 WWW.GROUSER.COM

TITLE: Hydraulic Angle - No Tilt	Date: 2-15-2011
-------------------------------------	--------------------

THE INFORMATION CONTAINED IN THIS DRAWING IS THE SOLE PROPERTY OF GROUSER PRODUCTS INC. ANY REPRODUCTION IN PART OR WHOLE WITHOUT THE WRITTEN PERMISSION OF GROUSER PRODUCTS INC. IS PROHIBITED.

Hydraulic Angle - No Tilt

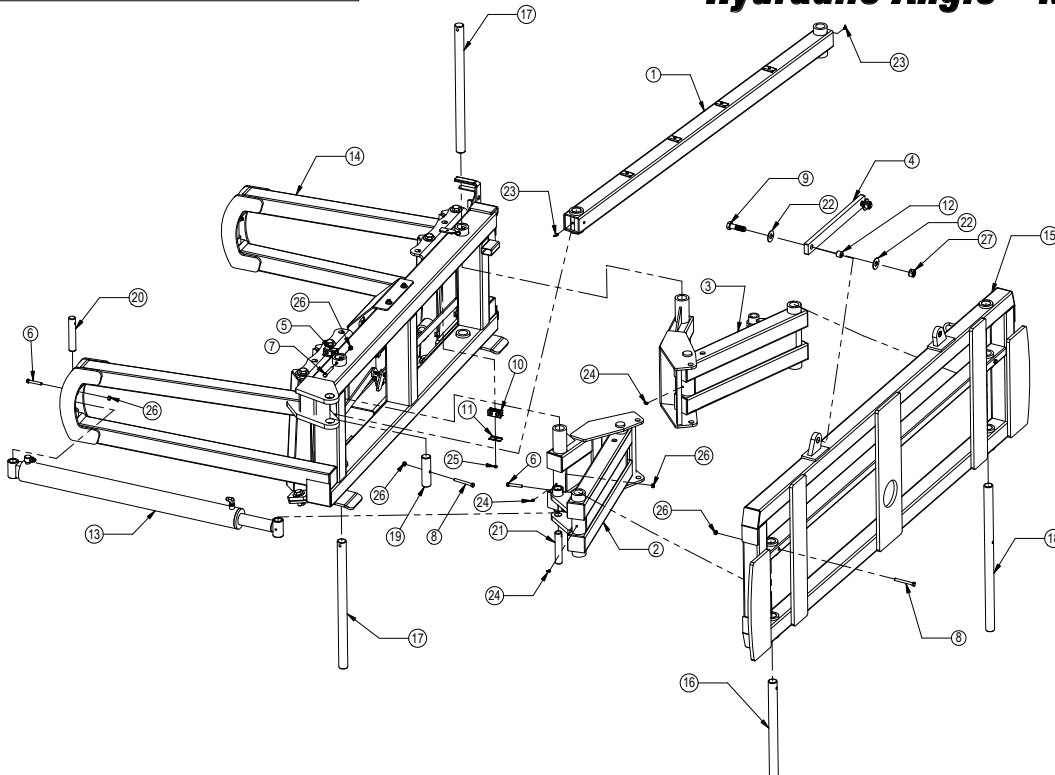

GROUSER PRODUCTS INC.
 755 2nd Ave NW Phone 701.282.7710
 West Fargo, ND 58078 Fax 701.282.8131
 WWW.GROUSER.COM

TITLE: Hydraulic Angle - No Tilt	Date: 2-15-2011
-------------------------------------	--------------------

THE INFORMATION CONTAINED IN THIS DRAWING IS THE SOLE PROPERTY OF GROUSER PRODUCTS INC. ANY REPRODUCTION IN PART OR WHOLE WITHOUT THE WRITTEN PERMISSION OF GROUSER PRODUCTS INC. IS PROHIBITED.

Hydraulic Angle and No Tilt Hose Routing

Item No.	Qty.	Part No.	Description
1	3	16-20036	5/16" x 1-1/2" Hex Bolt Gr 5 NC
2	1	16-20038	5/16" x 2" Hex Bolt Gr 5 NC
3	4	18-3074	Hose Hold Down Clamp
4	4	18-3075	Hose Hold Down Clamp Plate
5	1	18-8973	Coupler Mounting Bracket (5006-4)
6	2	25-34321	Tappet Quick Coupler Female (8250-16)
7	4	25-34322	Tappet Quick Coupler Male (8010-16)
8*	4	25-3455	Pioneer Dust Cap Angle (Red)
9*	2	25-3456	Pioneer Dust Plug Angle (Red)
10	2	26-34725	4x43.5 Cylinder w/ tube ends - Top Port (647196)
11*	1	31-13332	-6 SAE Breather Fitting
12	7	31-34040	Straight JIC x O-Ring (6400-8-8)
13	3	31-34050	Straight Thread Elbow 90° JIC x O-Ring (6801-8-8)
14	6	31-34051	Straight Thread Elbow 90° JIC x O-Ring (6801-08-10)
15	1	31-34100	Swivel Nut Elbow 90° JIC (6500-8-8)
16	2	35-30121	35" x 1/2" -8JIC/-8JIC Hose (R16)
17	2	35-30134	75" x 1/2" -8JIC/-8JIC Hose (R16)
18	2	35-30145	108" x 1/2" -8JIC/-8JIC Hose (R16)
19	2	35-30162	390" x 1/2" -8JIC/-8JIC Hose (R16)
20	1	56-13305	Hydraulic Valve
21	1	57-20744	1/2" Flat Washer
22*	1	69-13351	Wire Harness - Valve to Disconnect
23*	1	69-1531	Wire Harness - Disconnect to Tractor
24*	1	70-20581	5/16" Hex Nut Gr 5 NC
25	1	70-20604	1/2" Hex Center Lock Nut Gr 5 NC

* Parts not shown.

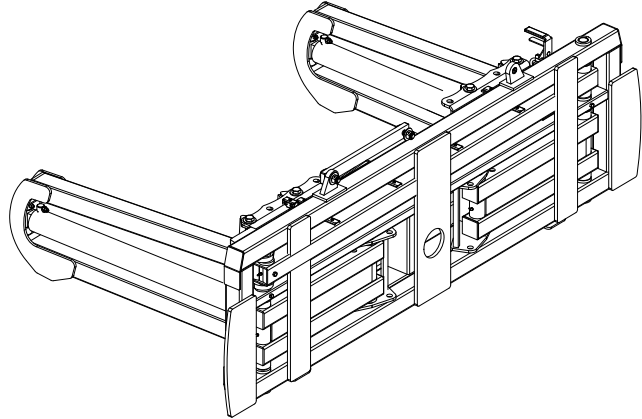

NOTE: When ordering cylinder seal kits, the part number on the cylinder is needed. The number is stamped on the base end of the cylinder opposite of the hydraulic ports.

No. On Cylinder	Part No.	Description
26-34725	49-12274	Seal Kit 4" x 43.5" (647210) Nitrided Rod
C40-179A10	49-1536	Seal Kit 4x2-1/2" (SKC40-163A) Nitrided Rod, Tube Ends



GROUSER PRODUCTS INC.

755 2nd Ave NW Phone 701.282.7710
West Fargo, ND 58078 Fax 701.282.8131
WWW.GROUSER.COM

TITLE: Hydraulic Angle and No Tilt Hose Routing

Date: 2-21-2011

THE INFORMATION CONTAINED IN THIS DRAWING IS THE SOLE PROPERTY OF GROUSER PRODUCTS INC. ANY REPRODUCTION IN PART OR WHOLE WITHOUT THE WRITTEN PERMISSION OF GROUSER PRODUCTS INC. IS PROHIBITED.

Hydraulic Angle and No Tilt Hose Routing

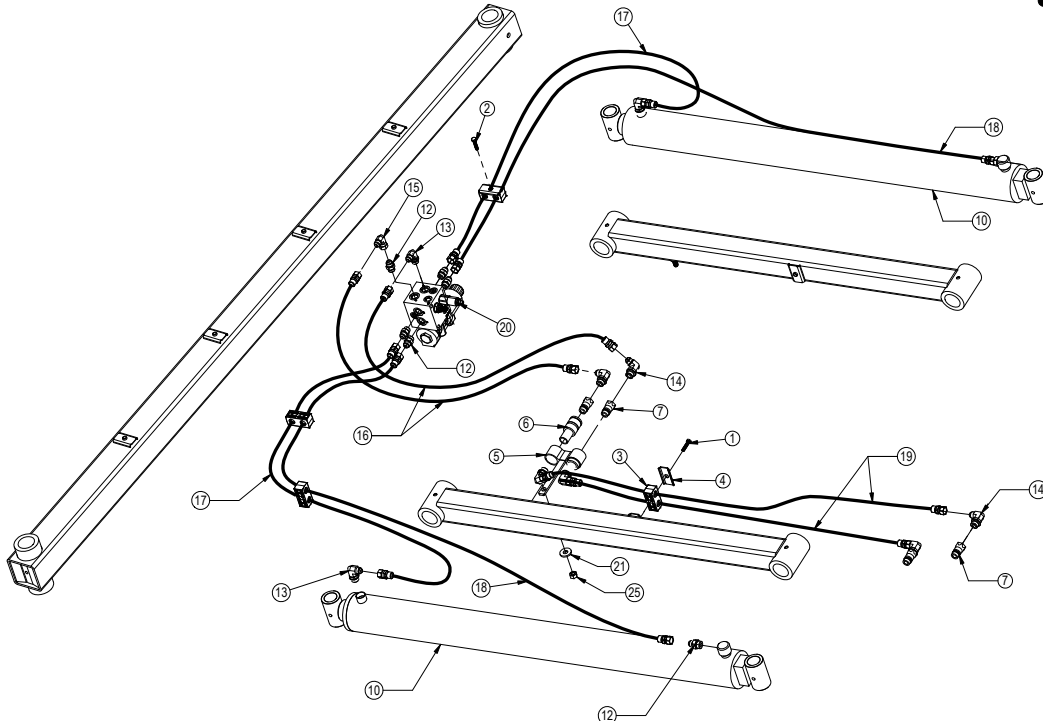

Hoses are not drawn to scale.



GROUSER PRODUCTS INC.

755 2nd Ave NW Phone 701.282.7710
West Fargo, ND 58078 Fax 701.282.8131
WWW.GROUSER.COM

TITLE: Hydraulic Angle and No Tilt Hose Routing

Date: 2-21-2011

THE INFORMATION CONTAINED IN THIS DRAWING IS THE SOLE PROPERTY OF GROUSER PRODUCTS INC. ANY REPRODUCTION IN PART OR WHOLE WITHOUT THE WRITTEN PERMISSION OF GROUSER PRODUCTS INC. IS PROHIBITED.

No Angle - Hydraulic Tilt

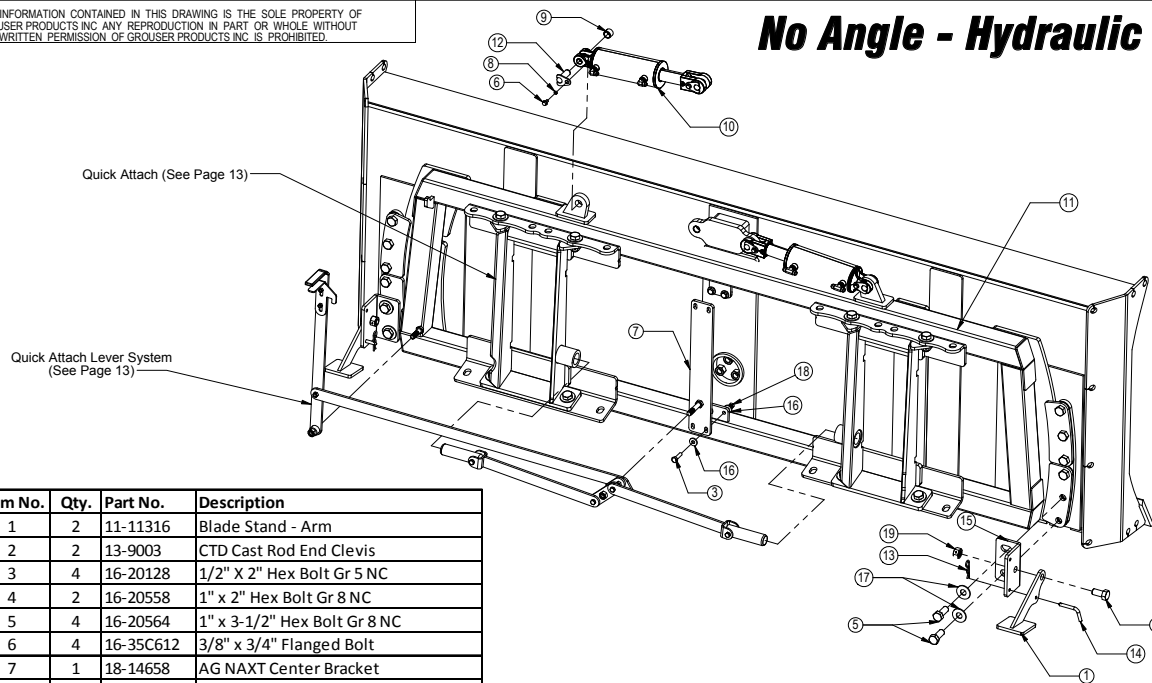

Item No.	Qty.	Part No.	Description
1	2	11-11316	Blade Stand - Arm
2	2	13-9003	CTD Cast Rod End Clevis
3	4	16-20128	1/2" X 2" Hex Bolt Gr 5 NC
4	2	16-20558	1" x 2" Hex Bolt Gr 8 NC
5	4	16-20564	1" x 3-1/2" Hex Bolt Gr 8 NC
6	4	16-35C612	3/8" x 3/4" Flanged Bolt
7	1	18-14658	AG NAXT Center Bracket
8	4	19-13577	NR Pin Spacer Clevis End
9	2	19-7774	1"x1" Spring Bushing
10	2	26-34711	4 x 8 Cylinder W/ Cast Clevis Ends
11	1	32-14560	450, 660, 760, 770 NAHT Tilt Frame
12	4	43-13580	1" Clevis Bolt In Pin
13	2	43-7767	Hitch Pin Clip
14	2	43-9582	1/2" x 2 1/2" Bent Claw Pin
15	2	44-11315	Blade Stand - Plate
16	8	57-20744	1/2" Flat Washer
17	4	57-20749	1" Flat Washer
18	4	70-20604	1/2" Hex Center Lock Nut Gr 2 NC
19	2	70-20609	1" Hex Center Lock Nut Gr 2 NC

GROUSER PRODUCTS INC.
 755 2nd Ave NW Phone 701.282.7710
 West Fargo, ND 58078 Fax 701.282.8131
 WWW.GROUSER.COM

TITLE: No Angle Hydraulic Tilt Date: 2/23/2011

THE INFORMATION CONTAINED IN THIS DRAWING IS THE SOLE PROPERTY OF GROUSER PRODUCTS INC. ANY REPRODUCTION IN PART OR WHOLE WITHOUT THE WRITTEN PERMISSION OF GROUSER PRODUCTS INC. IS PROHIBITED.

No Angle - Hydraulic Tilt Hose Routing

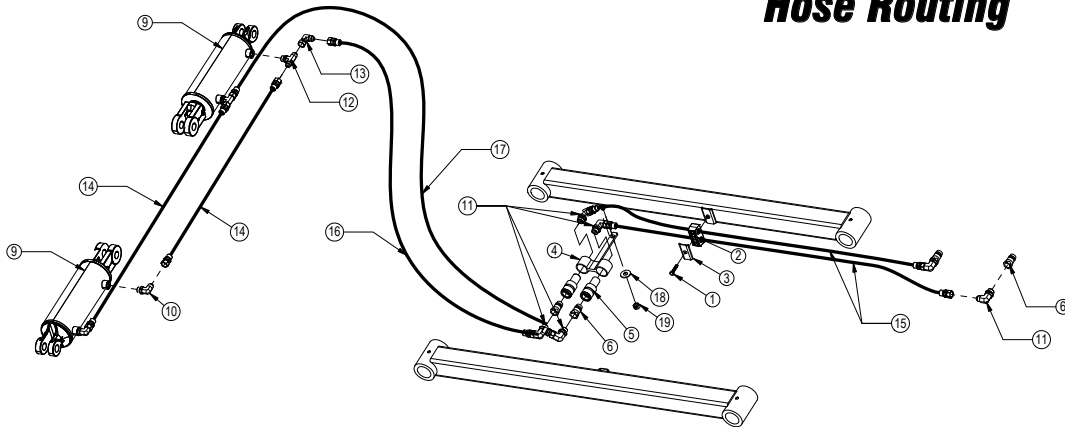

* Parts not shown.

Item No.	Qty.	Part No.	Description
1	1	16-20036	5/16" x 1-1/2" Hex Bolt Gr 5 NC
2	1	18-3074	Hose Hold Down Clamp
3	1	18-3075	Hose Hold Down Clamp Plate
4	1	18-8973	Coupler Mounting Bracket (5006-4)
5	2	25-34321	Tappet Quick Coupler Female (8250-16)
6	4	25-34322	Tappet Quick Coupler Male (8010-16)
7*	4	25-3453	Pioneer Dust Cap Tilt (Green)
8*	2	25-3454	Pioneer Dust Plug Tilt (Green)
9	2	26-34711	4x8 Cylinder w/ clevis ends (647134)
10	2	31-34050	Straight Thread Elbow 90° JIC x O-Ring (6801-8-8)
11	6	31-34051	Straight Thread Elbow 90° JIC x O-Ring (6801-08-10)
12	2	31-34060	Branch Tee JIC x O-Ring (6803-8-8-8)
13	1	31-34100	Swivel Nut Elbow 90° JIC (6500-8-8)
14	2	35-30022	39" x 3/8" -8JIC/-8JIC Hose (R16)
15	2	35-30162	390" x 1/2" -8JIC/-8JIC Hose (R16)
16	1	35-31109	24" x 1/2" -8JIC/-8JIC Hose w/ Cordura (R16)
17	1	35-31115	30" x 1/2" -8JIC/-8JIC Hose w/ Cordura (R16)
18	1	57-20744	1/2" Flat Washer
19	1	70-20604	1/2" Hex Center Lock Nut Gr 5 NC

NOTE: When ordering cylinder seal kits, the part number on the cylinder is needed. The number is stamped on the base end of the cylinder opposite of the hydraulic ports.

No. On Cylinder	Part No.	Description
26-34711	49-12271	Seal Kit 4x8 (647135) Nitrided Rod, Clevis Ends
C40-158A	49-1534	Seal Kit 4x2 (SKC40-158A) Nitrided Rod, Clevis Ends

GROUSER PRODUCTS INC.
 755 2nd Ave NW Phone 701.282.7710
 West Fargo, ND 58078 Fax 701.282.8131
 WWW.GROUSER.COM

TITLE: No Angle - Hydraulic Tilt Hose Routing Date: 2-26-2011

THE INFORMATION CONTAINED IN THIS DRAWING IS THE SOLE PROPERTY OF GROUSER PRODUCTS INC. ANY REPRODUCTION IN PART OR WHOLE WITHOUT THE WRITTEN PERMISSION OF GROUSER PRODUCTS INC IS PROHIBITED.

Angle Hydraulic Components

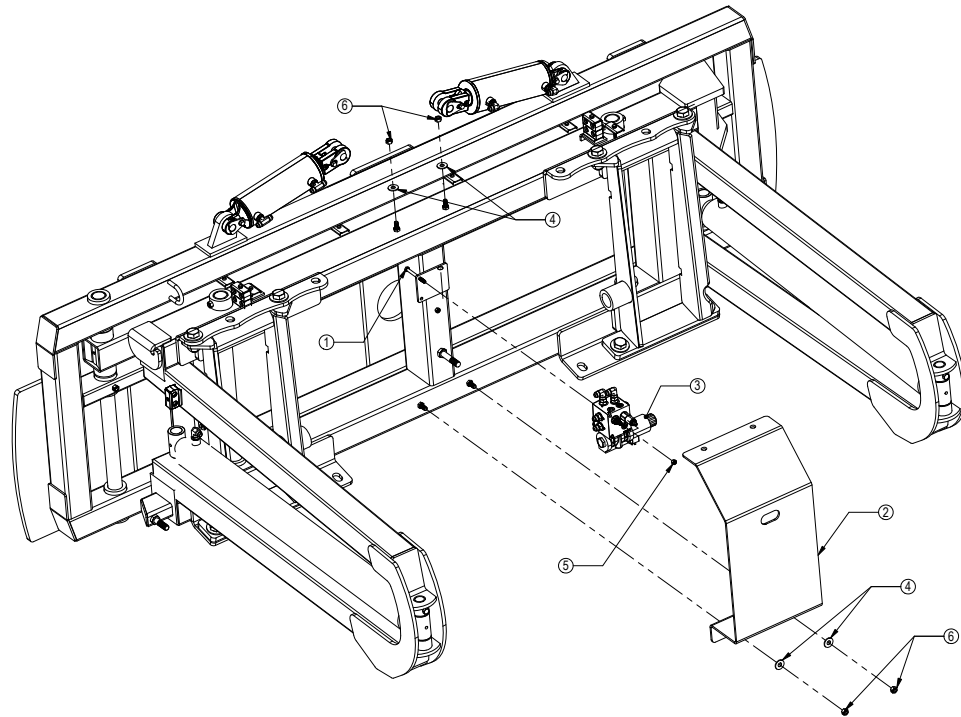

Item No.	Qty.	Part No.	Description
1	2	16-20077	3/8" x 4-1/2" Hex Bolt Gr 5 NC
2	1	18-1701	Hydraulic Valve Cover
3	1	56-13305	Hydraulic Valve
4	4	57-20744	1/2" Flat Washer
5	2	70-20582	3/8" Hex Nut
6	4	70-20604	1/2" Hex Center Lock Nut Gr 5 NC



GROUSER PRODUCTS INC.

755 2nd Ave NW Phone 701.282.7710
West Fargo, ND 58078 Fax 701.282.8131
WWW.GROUSER.COM

TITLE:
Angle Hydraulic Components

Date:
2-21-2011

THE INFORMATION CONTAINED IN THIS DRAWING IS THE SOLE PROPERTY OF GROUSER PRODUCTS INC. ANY REPRODUCTION IN PART OR WHOLE WITHOUT THE WRITTEN PERMISSION OF GROUSER PRODUCTS INC IS PROHIBITED.

Quick Attach System

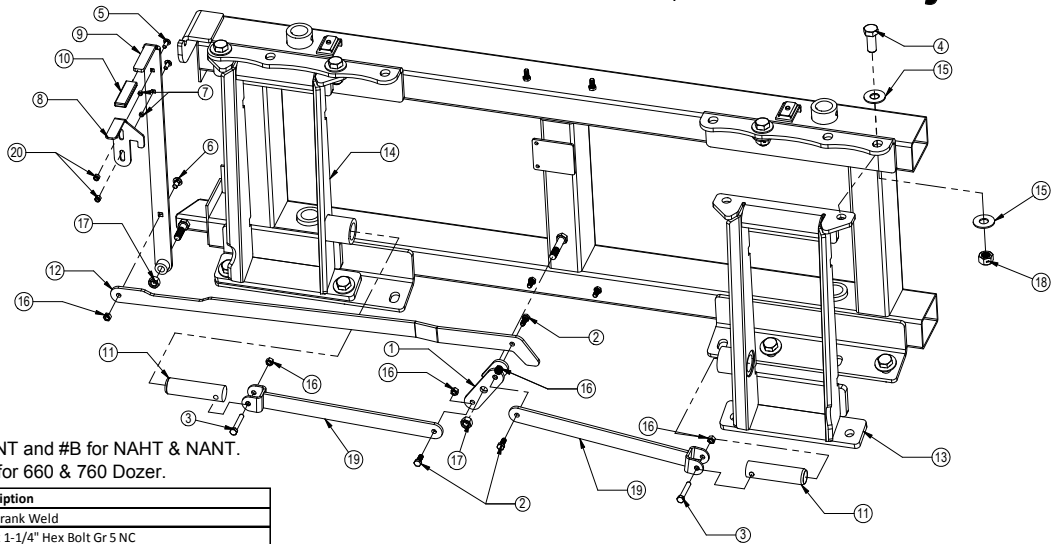

Item #A for HAHT & HANT and #B for NAHT & NANT.
Item #C for 450 and #D for 660 & 760 Dozer.

Item No.	Qty.	Part No.	Description
1	1	11-3049	Bell Crank Weld
2	3	16-20125	1/2" x 1-1/4" Hex Bolt Gr 5 NC
3	2	16-20132	1/2" x 3" Hex Bolt Gr 5 NC Zinc
4	8	16-20560	1" x 2-1/2" Hex Bolt Gr 8 NC
5	2	16-21064	3/8" x 1" Carriage Bolt
6	1	16-21125	1/2" x 1-1/4" Carriage Bolt
7	2	19-13577	NR Pin Spacer Clevis End
8	1	39-14663	AG Pin Puller Latch
9	1	39-14665	AG Pin Puller Handle Weld
10	1	39-3072	Handle Cover (Orange)
11	2	43-3050	QA Lock Pin
12A	1	44-14709	450, 660 & 760 Pin Puller Link Plate
12B	1	44-14662	AG Pro Pin Puller Link Plate
13	1	45-14710-R	AG Pro Female Vertical Bolt On Quick Attach, Right
14	1	45-14710-L	AG Pro Female Vertical Bolt On Quick Attach, Left
15	16	57-20819	1" Flat Washer Heavy Duty Gr 8 (USS)
16	6	70-20604	1/2" Hex Center Lock Nut Gr 2 NC
17	2	70-20607	3/4" Hex Center Lock Nut Gr 2 NC
18	8	70-20609	1" Hex Center Lock Nut Gr 2 NC
19C	2	75-3053	450 QA Fork - Link Weld
19D	2	75-5053	660 & 760 QA Fork - Link Weld
20	2	70-59D6	Nut Polylock 3/8"-16

Some Parts Hidden For Clarity



GROUSER PRODUCTS INC.

755 2nd Ave NW Phone 701.282.7710
West Fargo, ND 58078 Fax 701.282.8131
WWW.GROUSER.COM

TITLE:
Quick Attach System

Date:
2/22/2011

THE INFORMATION CONTAINED IN THIS DRAWING IS THE SOLE PROPERTY OF GROUSER PRODUCTS INC. ANY REPRODUCTION IN PART OR WHOLE WITHOUT THE WRITTEN PERMISSION OF GROUSER PRODUCTS INC. IS PROHIBITED.

No Angle - No Tilt With Tilt Frame

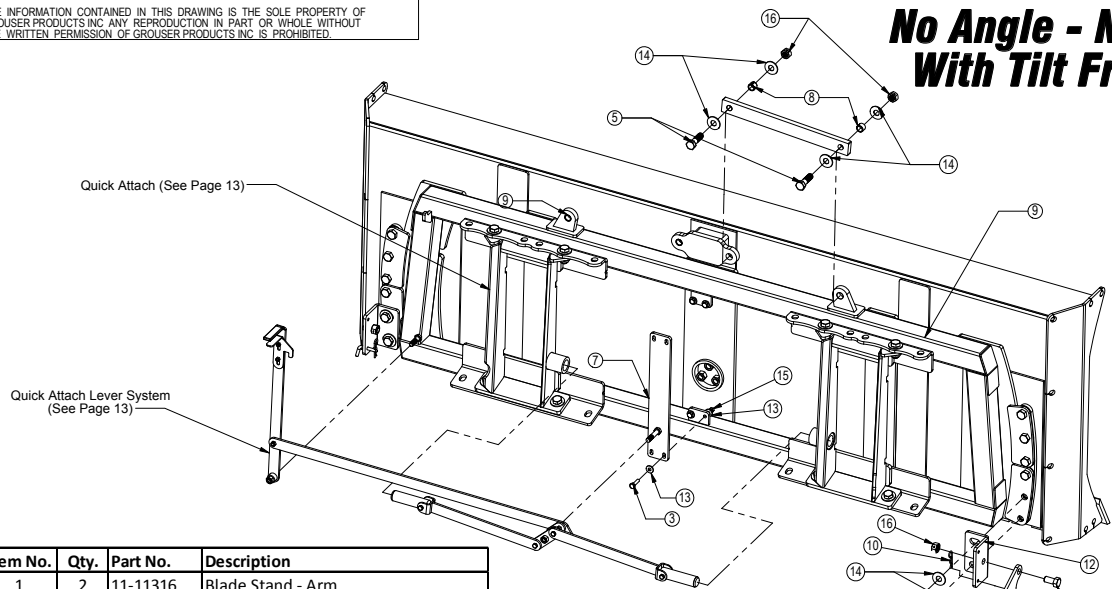

Item No.	Qty.	Part No.	Description
1	2	11-11316	Blade Stand - Arm
2	1	14-9366	Non Tilt Bar
3	4	16-20128	1/2" X 2" Hex Bolt Gr 5 NC
4	2	16-20558	1" x 2" Hex Bolt Gr 8 NC
5	6	16-20564	1" x 3-1/2" Hex Bolt Gr 8 NC
6	4	16-35C612	3/8" x 3/4" Flanged Bolt
7	1	18-14658	AG NAXT Center Bracket
8	2	19-7774	1"x1" Spring Bushing
9	1	32-14560	450, 660, 760, 770 NAHT Tilt Frame
10	2	43-7767	Hitch Pin Clip
11	2	43-9582	1/2" x 2 1/2" Bent Claw Pin
12	2	44-11315	Blade Stand - Plate
13	8	57-20744	1/2" Flat Washer
14	8	57-20749	1" Flat Washer
15	4	70-20604	1/2" Hex Center Lock Nut Gr 2 NC
16	4	70-20609	1" Hex Center Lock Nut Gr 2 NC



GROUSER PRODUCTS INC.

755 2nd Ave NW Phone 701.282.7710
West Fargo, ND 58078 Fax 701.282.8131
WWW.GROUSER.COM

TITLE: No Angle Hydraulic Tilt

Date: 2/26/2011

THE INFORMATION CONTAINED IN THIS DRAWING IS THE SOLE PROPERTY OF GROUSER PRODUCTS INC. ANY REPRODUCTION IN PART OR WHOLE WITHOUT THE WRITTEN PERMISSION OF GROUSER PRODUCTS INC. IS PROHIBITED.

Hydraulic Angle 2 Lever System (Option)

No. On	Cylinder	Part No.	Description
26	34725	49-12274	Seal Kit 4" x 43.5" (647210) Nitrided Rod
C40-179A10	49-1536	Seal Kit 4x2-1/2" (SKC40-163A) Nitrided Rod, Tube Ends	

NOTE: When ordering cylinder seal kits, the part number on the cylinder is needed. The number is stamped on the base end of the cylinder opposite of the hydraulic ports.

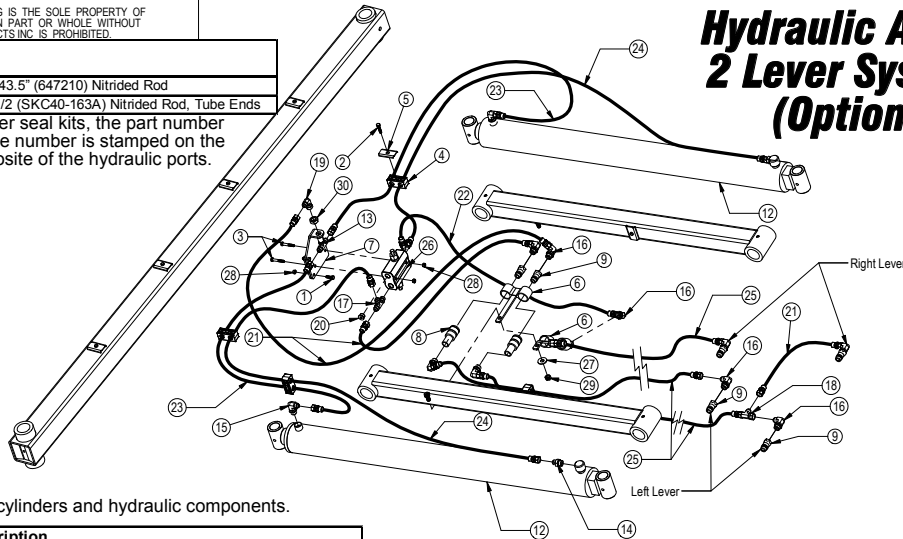

* Parts not shown.

Refer to Page 9 or 12 for tilt cylinders and hydraulic components.

Item No.	Qty.	Part No.	Description
1	2	16-20034	5/16" x 1" Hex Bolt Gr 5 NC
2	2	16-20036	5/16" x 1-1/2" Hex Bolt Gr 5 NC
3	2	16-20040	5/16" x 2-1/2" Hex Bolt Gr 5 NC
4	5	18-3074	Hose Hold Down Clamp
5	4	18-3075	Hose Hold Down Clamp Plate
6	2	18-8973	Coupler Mounting Bracket (5006-4)
7	1	18-14695	Bracket, Relief Valve
8	3	25-34321	Tappet Quick Coupler Female (8250-16)
9	7	25-34322	Tappet Quick Coupler Male (8010-16)
10*	7	25-3455	Pioneer Dust Cap Angle (Red)
11*	3	25-3456	Pioneer Dust Plug Angle (Red)
12	2	26-34725	4x43.5 Cylinder w/ tube ends - Top Port (647196)
13	1	31-34020	Bulkhead Branch Tee JIC (2703-8-8-8)
14	2	31-34040	Straight JIC x O-Ring (6400-8-8)
15	2	31-34050	Straight Thread Elbow 90° JIC x O-Ring (6801-08-08)
16	10	31-34051	Straight Thread Elbow 90° JIC x O-Ring (6801-08-10)
17	2	31-34070	Run Tee JIC O-Ring (6804-8-8-8)
18	1	31-34090	Swivel Nut Run Tee JIC (6602-8-8-8)
19	1	31-34100	Swivel Nut Elbow 90° JIC (6500-8-8)
20	2	31-34123	Hex Socket O-Ring Plug (6409-8)

Item No.	Qty.	Part No.	Description
21	3	35-30121	35" x 1/2" -8JIC/-8JIC Hose (R16)
22	1	35-30127	54" x 1/2" -8JIC/-8JIC Hose (R16)
23	2	35-30134	75" x 1/2" -8JIC/-8JIC Hose (R16)
24	2	35-30145	108" x 1/2" -8JIC/-8JIC Hose (R16)
25	3	35-30162	390" x 1/2" -8JIC/-8JIC Hose (R16)
26	1	56-7772	Relief Valve
27	1	57-20744	1/2" Flat Washer
28	1	70-20581	5/16" Hex Nut Gr 5 NC
29	1	70-20604	1/2" Hex Center Lock Nut Gr 5 NC
30	1	70-20807	3/4" Hex Jam Nut NF



GROUSER PRODUCTS INC.

755 2nd Ave NW Phone 701.282.7710
West Fargo, ND 58078 Fax 701.282.8131
WWW.GROUSER.COM

TITLE: Hydraulic Angle 2 Lever System

Date: 2-26-2011

THE INFORMATION CONTAINED IN THIS DRAWING IS THE SOLE PROPERTY OF GROUSER PRODUCTS INC. ANY REPRODUCTION IN PART OR WHOLE WITHOUT THE WRITTEN PERMISSION OF GROUSER PRODUCTS INC. IS PROHIBITED.

Lift System

Item #A for 4200 and Item #B for 6200.

Item No.	Qty.	Part No.	Description
1	1	11-5025-L	4X00, 5X00, 6X00 Top Arm Left
2	1	11-5025-R	4X00, 5X00, 6X00 Top Arm Right
3	4	16-1795	Lift Frame Grease Bolt
4	8	16-20216	3/4" x 1-1/2" Hex Bolt Gr 5 NC
5	2	16-20220	3/4" x 2-1/2" Hex Bolt Gr 5 NC
6	2	16-20227	3/4" x 4-1/2" Hex Bolt Gr 5 NC
7	10	19-13515	3/4" ID Pin Spacer Bushing
8	4	19-1794	Lift Frame Bushing w/ Tapped Hole
9	2	26-34738	4x20 Long Cylinder - Bushed Tube Ends (347267)
10A	1	32-13020	4200 Lift Frame
10B	1	32-13110	6200 Lift Frame
11	2	43-13025	4X00, 6X00 Pin (Lift Frame / UC)
12	2	43-5033	4X00, 5X00, 6X00 Pin Weld (Lift Cyl. / Lift Frame)
13	2	43-5035	4X00, 5X00, 6X00 Pin Weld (Lift Cyl. / UC)
14	2	43-5037	4X00, 5X00, 6X00 Pin Weld (Top Arm / UC)
15	2	43-5042	4X00, 5X00, 6X00 Pin Weld (Top Arm / QA)
16	2	43-8896	QA Bottom 2-7/16" x 9" Pin
17	1	45-5075	4X00, 5X00, 6X00 QA Male
18	10	57-20747	3/4" Flat Washer
19	6	58-9369	Grease Zerk 1/8" NPT Straight
20	2	58-9371	Grease Zerk 1/8" NPT 45°
21	2	70-20607	3/4" Hex Center Lock Nut Gr 5 NC

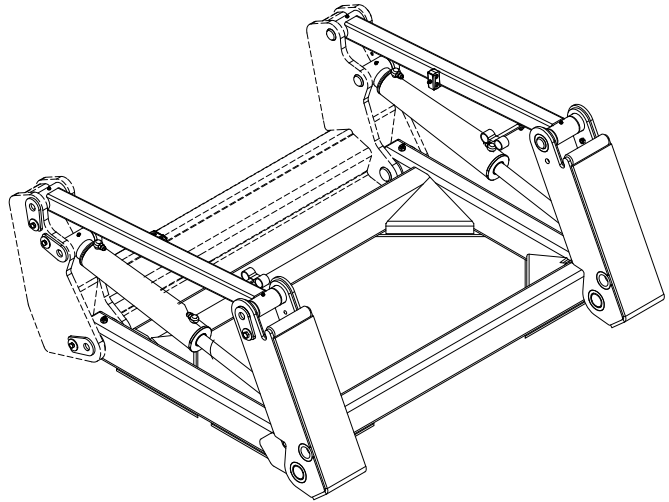

Refer to Page 16 for hydraulic components and hoses.



GROUSER PRODUCTS INC.

755 2nd Ave NW Phone 701.282.7710
West Fargo, ND 58078 Fax 701.282.8131
WWW.GROUSER.COM

TITLE:

Lift System

Date:

3-4-2010

THE INFORMATION CONTAINED IN THIS DRAWING IS THE SOLE PROPERTY OF GROUSER PRODUCTS INC. ANY REPRODUCTION IN PART OR WHOLE WITHOUT THE WRITTEN PERMISSION OF GROUSER PRODUCTS INC. IS PROHIBITED.

Lift System

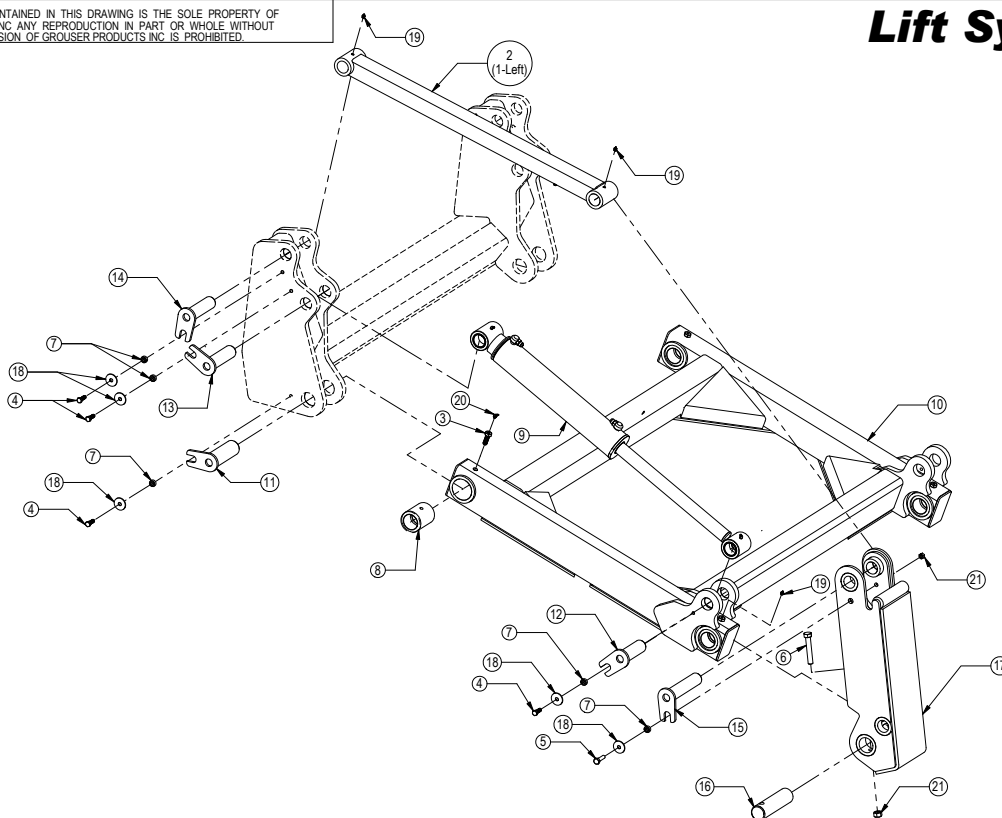

Note: Parts shown for right side. Left side is identical.



GROUSER PRODUCTS INC.

755 2nd Ave NW Phone 701.282.7710
West Fargo, ND 58078 Fax 701.282.8131
WWW.GROUSER.COM

TITLE:

Lift System

Date:

3-4-2010

THE INFORMATION CONTAINED IN THIS DRAWING IS THE SOLE PROPERTY OF GROUSER PRODUCTS INC. ANY REPRODUCTION IN PART OR WHOLE WITHOUT THE WRITTEN PERMISSION OF GROUSER PRODUCTS INC. IS PROHIBITED.

Lift System Hydraulic Components

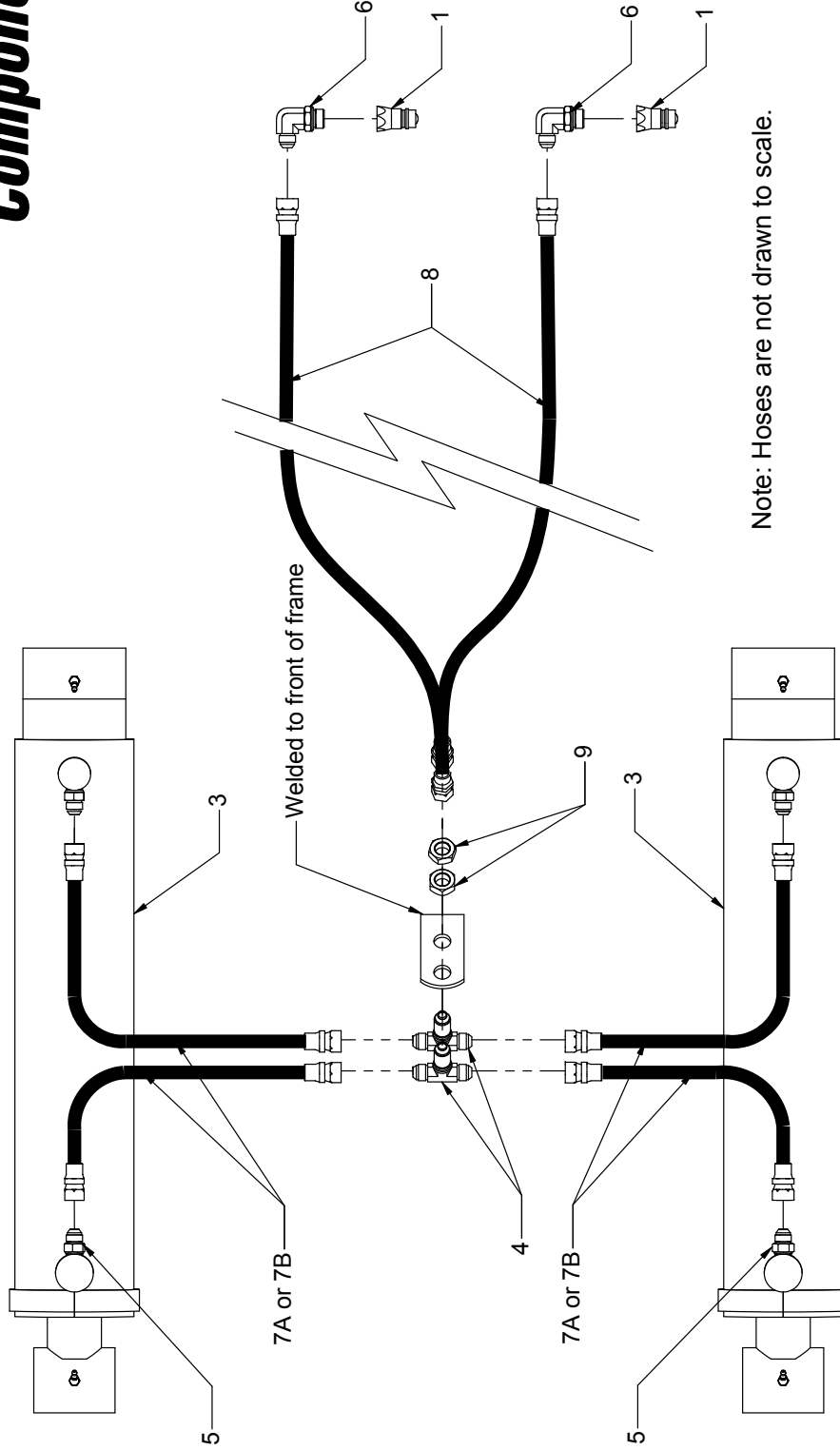

Note: Hoses are not drawn to scale.

NOTE: When ordering cylinder seal kits, the part number on the cylinder is needed. The number is stamped on the base end of the cylinder opposite of the hydraulic ports.

* Part Not Shown.

Item #A for 450 and #B for 660 Dozer.

Item No.	Qty.	Part No.	Description
1	2	25-34322	Tappet Quick Coupler Male (8010-16)
2*	2	25-3457	Pioneer Dust Cap Lift (Orange)
3	2	26-34738	4x20 Long Cylinder - Bushed Tubed Ends (647267)
4	2	31-34020	Bulkhead Branch Tee JIC (2703-8-8-8)
5	4	31-34040	Straight JIC x O-Ring (6400-8-8)
6	2	31-34051	Straight Thread Elbow 90° JIC x O-Ring (6801-08-10)
7A	4	35-30131	66" x 1/2" -8JIC/-8JIC Hose
7B	4	35-30134	75" x 1/2" -8JIC/-8JIC Hose
8	2	35-30160	288" x 1/2" -8JIC/-8JIC Hose
9	2	70-20807	3/4" Hex Jam Nut NF

No. On Cylinder	Part No.	Description
26-34738	49-12272	Seal Kit 4" Bore x 2" Rod (647204) Nitrided Rod
C40-201A	49-1535	Seal Kit 4x2" (SKC40-162A) Nitrided Rod, Tube Ends



GROUSER PRODUCTS INC.

755 2nd Ave NW
West Fargo, ND 58078
WWW.GROUSER.COM
Phone 701.282.7710
Fax 701.282.8131

TITLE: Lift System Hydraulic Components

Date: 2-26-2011

THE INFORMATION CONTAINED IN THIS DRAWING IS THE SOLE PROPERTY OF GROUSER PRODUCTS, INC. ANY REPRODUCTION IN PART OR WHOLE WITHOUT THE WRITTEN PERMISSION OF GROUSER PRODUCTS, INC. IS PROHIBITED.

Wiring Harness and Electrical System

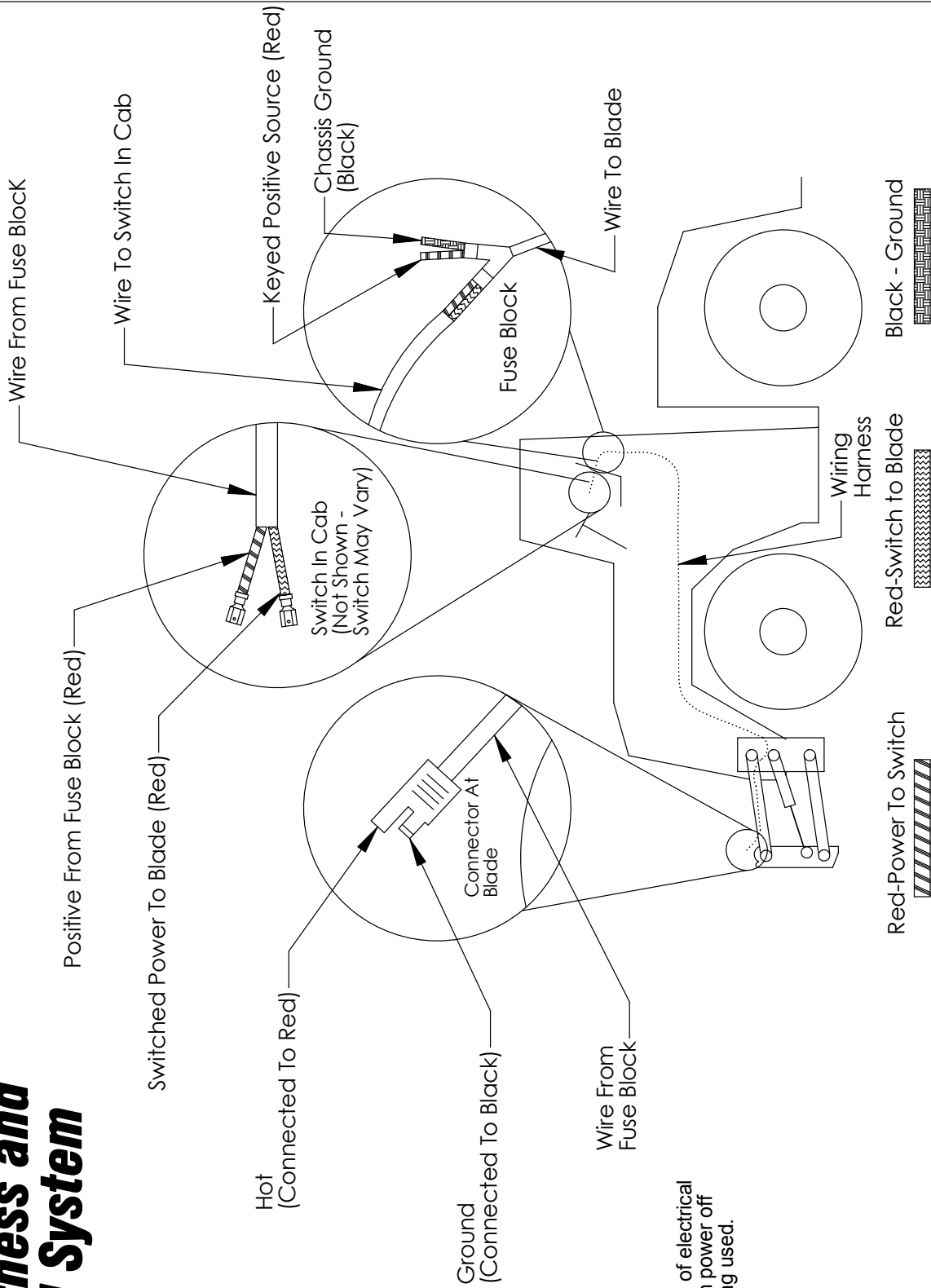

Note: To maximize life of electrical system and valve, turn power off when dozer is not being used.

Instructions

1. Locate "keyed and fused" 12 V power supply in cab of tractor.
2. Disconnect battery.
3. Connect the red wire to power and the black wire to ground.
4. Install switch in convenient place in cab.
5. Route wire harness from switch to the blade. (plug-in connector at blade)
6. Connect the switch to the wire harness.
7. Reconnect the battery.



GROUSER PRODUCTS INC.
 755 2nd Ave NW Phone 701.282.7710
 West Fargo, ND 58078 Fax 701.282.8131
 WWW.GROUSER.COM

TITLE: **Wiring Harness and Electrical System** Date: **6-26-2011**

THE INFORMATION CONTAINED IN THIS DRAWING IS THE SOLE PROPERTY OF GROUSER PRODUCTS INC. ANY REPRODUCTION IN PART OR WHOLE WITHOUT THE WRITTEN PERMISSION OF GROUSER PRODUCTS INC. IS PROHIBITED.

Hydraulic Schematic

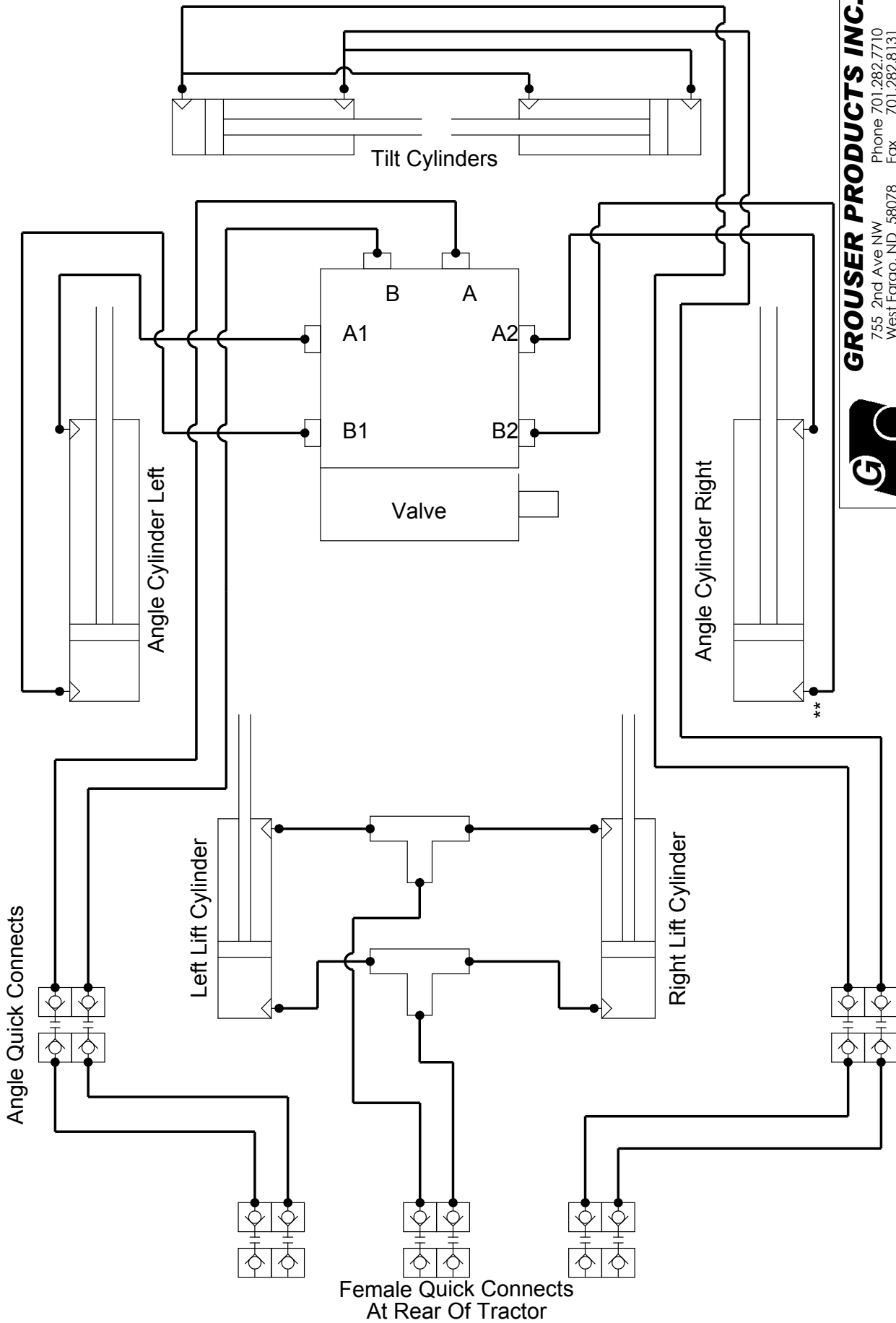

GROUSER PRODUCTS INC.

755 2nd Ave NW
West Fargo, ND 58078
Phone 701.282.7710
Fax 701.282.8131
WWW.GROUSER.COM

TITLE:

Hydraulic Schematic

Date:

3-26-2011

** Denotes location of gauge for adjustment of relief valve.

THE INFORMATION CONTAINED IN THIS DRAWING IS THE SOLE PROPERTY OF GROUSER PRODUCTS INC ANY REPRODUCTION IN PART OR WHOLE WITHOUT THE WRITTEN PERMISSION OF GROUSER PRODUCTS INC IS PROHIBITED.

2 - Lever System Hydraulic Schematic

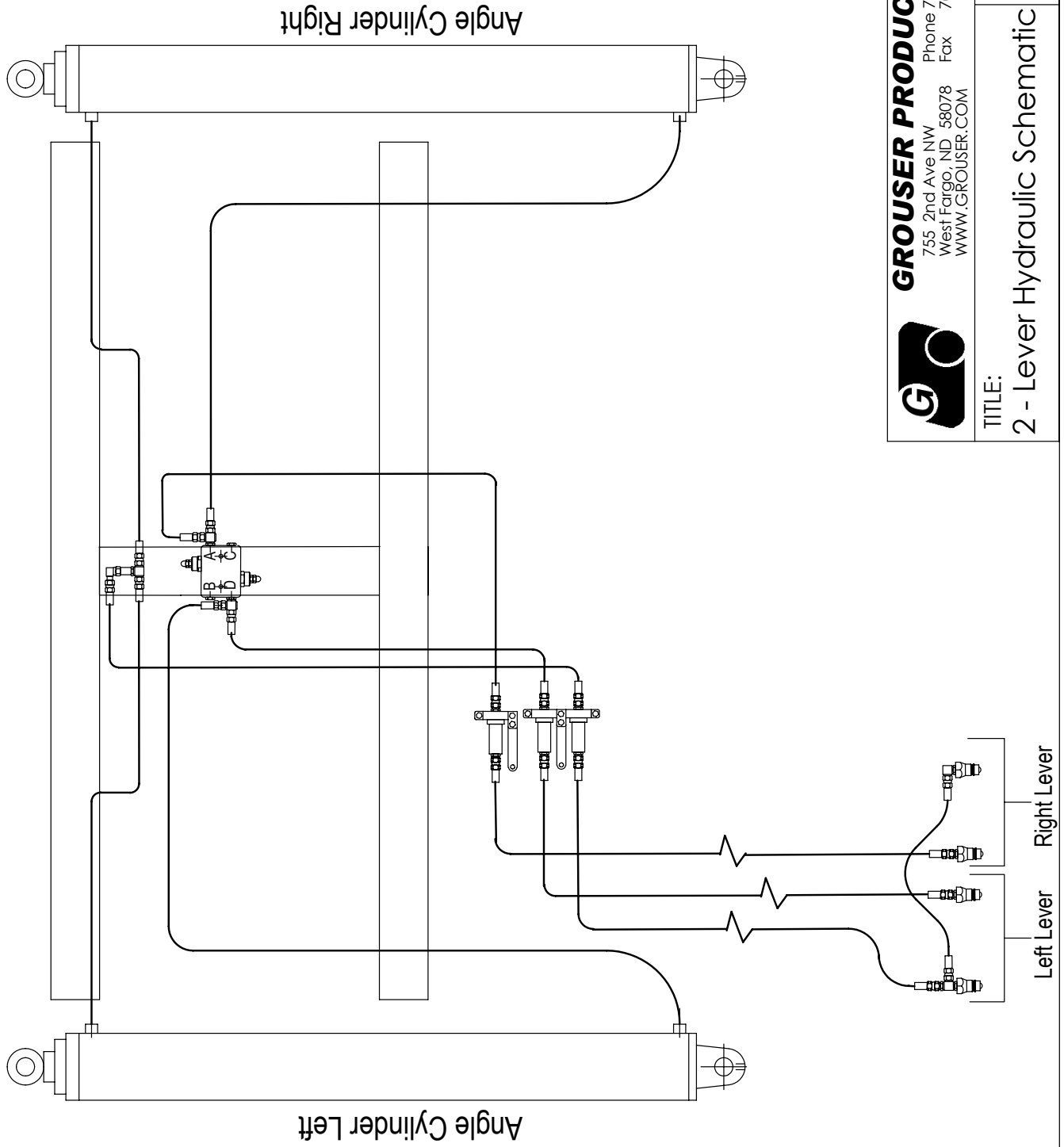

GROUSER PRODUCTS INC.

755 2nd Ave NW
West Fargo, ND 58078
WWW.GROUSER.COM

Phone 701.282.7710
Fax 701.282.8131

TITLE:

2 - Lever Hydraulic Schematic

Date:

2-19-2007

Contact Us

As always, if you have any questions about your 450 and 660 Dozer or other products made by Grouser, feel free to contact us.

Grouser Products

755 2nd Ave NW - West Fargo, ND 58078

Phone: 1-800-747-6182

Fax: 1-701-282-8131

E-mail: grouser@grouser.com

Website: www.grouser.com

Improvements

Grouser Products Inc. is continually striving to improve its products. We reserve the right to change prices, specification, or equipment at any time without notice. We also reserve the right to make improvements or changes when it becomes practical and possible to do so without incurring any obligation to make changes or additions to the equipment sold previously.

Warranty

Grouser Products warrants to the original purchaser of each item that the product be free from defects in material and workmanship under normal use and service for a period of one year. If such equipment is found to be defective within one year, it is the obligation of Grouser Products under this warranty to repair or replace (exclusive of the cost of labor and transportation), any equipment or parts, in the judgment of Grouser Products to be defective in material or workmanship.

All equipment or parts claimed to be defective in material or workmanship must be made available for inspection at the place of business of a dealer authorized to handle the equipment covered by this warranty, or, upon request by Grouser Products, shipped to the Grouser Products factory in West Fargo, North Dakota. Grouser Products shall have no obligation to bear the cost of labor or transportation in connection with replacement or repair of any such defective parts in the setup process.

This warranty covers only defects in material and workmanship. It does not cover depreciation or damage caused by normal wear, accident, improper assembly, improper adjustments, improper maintenance including lack of proper lubrication, or improper use. Therefore, Grouser Products liability under this warranty shall not be effective or actionable unless the equipment is assembled, maintained and operated in accordance with the operating instructions accompanying the equipment. Grouser Products shall have no liability if the equipment has been altered or reworked without the written authorization of Grouser Products.

Grouser Products' parts, which are furnished under this warranty and properly installed, shall be warranted to the same extent as the original parts under this warranty if, and only if, such parts are found to be defective within the original warranty period covering the original equipment.

