



760 Owner's Manual & Parts Book

Purchase Date
Serial Number
Model Number
Tractor Model
Dealer

Contents

Description	Page
To The Owner, Maintenance	2
Safety Precautions & Torque Specifications	3
Skid Shoe and Tilt Plate Adjustment	4
Angle / Tilt Function Abbreviation Key	4
Blade Assembly & NANT Blade Assembly	5
Hydraulic Instructions, Angle System & 2-Lever Angle System Operating Instructions	6
Relief Valve Instructions	7
Assembling Lift Components & Initial System Startup	8
Lift System	9
No Angle - Hydraulic Tilt System & Hydraulics	10-11
Angle Hydraulic Components	11
Quick Attach System	12-13
Hydraulic Angle - Hydraulic Tilt & Hydraulic Angle - No Tilt System	14-15
Hydraulic Angle - Hydraulic Tilt & Hydraulic Angle - No Tilt Hose Routing (Blade Side)	16-17
Hydraulic Angle - 2 Lever System Hose Routing (Blade Side)	18-19
Tractor Side Hydraulic Hose Routing	20-21
Hydraulic Connections & End Extensions	22-23
Wire Harness	24
Hydraulic Schematic	25
2- Lever Hydraulic Schematic	26
Notes, Contact Us, Improvements, & Warranty	27-28

To The Owner

This manual contains information concerning the operation, adjustment, and maintenance of the 760 blade assembly. You have purchased dependable, long lasting equipment, but only by proper care and operation can you expect to receive the performance and long service built into our products. Please have all operators read this manual carefully and keep the manual available for ready reference. If you have any questions or concerns, contact Grouser Products.

Maintenance

Due to the harsh environment many of our equipment operates in, the following tasks should be performed every 10 hours or less.

- Inspect all equipment before operation for existing or potential damages.
- Lubricate all joints with high quality grease.
- Inspect and tighten all bolts to torque specifications on page 3.
- Check replaceable cutting edge for wear ensuring there is enough material to prevent permanent damage to the blade.
- Make sure all non-rotating pins are secured properly.
- Check hydraulic cylinders and hoses for damage or leaks. For replacement parts, see hydraulic pages for your specific system.
- Check skid shoes for wear and replace if necessary. For adjustment, see page 4.
- Inspect all tilt-ways for aggressive wear. See page 4 for tilt plate adjustment.

Safety Precautions

A careful operator is the best operator. Most accidents can be avoided by observing certain precautions. To help prevent accidents, read and take the following precautions before operating this equipment. In addition to these precautions, please follow all safety and operational instructions of your tractor manufacturer.

The Dozer:

1. The 760 Dozer should be operated only by those who are responsible and instructed to do so.
2. Read the owner's manual carefully before using this equipment. Lack of operating knowledge can lead to accidents.
3. Keep the dozer maintained in reliable and satisfactory condition to ensure your safety.
4. Make sure the area is clear of people before moving any equipment.
5. Do not modify or permit anyone else to modify or alter the equipment and its components without first consulting Grouser Products.

Servicing the Dozer:

1. Read and follow all safety instructions provided by the tractor manufacturer.
2. Always use proper personal safety gear when performing maintenance on equipment.
3. Before servicing, relieve hydraulic pressure, stop engine and fully engage parking brake.
4. Escaping hydraulic fluid under pressure can penetrate skin causing serious injury. If fluid is injected into skin, obtain medical attention immediately.
 - DO NOT use your hand to check for leaks. Use a piece of cardboard or paper to search for leaks.
 - Stop the engine and relieve pressure before connecting or disconnecting lines.
 - Tighten all connections before starting the engine or pressurizing lines.

Storing the Dozer:

1. Thoroughly clean the inside and outside of the dozer before storage. Use paint where necessary to prevent rust.
2. Check the dozer for worn or damaged parts. Install new parts as required.
3. Lubricate all pins and joints.

Torque Specifications

All bolts should be tightened to the specifications that are stated. If specifications are not stated, follow torque charts below.

Size	Torque - Dry (ft-lbs)			
	SAE Grade 5		SAE Grade 8	
	UNC	UNF	UNC	UNF
5/16	17	19	24	27
3/8	30	35	45	50
7/16	50	55	70	80
1/2	75	85	110	120
9/16	110	120	150	170
5/8	150	170	210	240
3/4	260	300	380	420
7/8	430	470	600	670
1	640	720	910	1020

	Torque - Dry (ft-lbs)
Size	Grade 10.9
M18 x 2.50	284
M20 x 2.50	401
M22 x 2.50	547
M24 x 3.00	694

Skid Shoe and Tilt Plate Adjustment

Skid Shoe Adjustment:

1. Raise and secure blade to access skid shoe bolts and nuts.
2. Loosen nuts and set skid shoe depth by sliding the shoe back and forth in direction 'A' shown in Figure 1.
3. Once the depth is set, tighten bolts to 150 ft-lbs.
4. When skid shoes are worn down, replace with new skid shoes.

Tilt Plate Adjustment:

1. Remove bolts and tilt plates.

Note: Don't remove all of the bolts at the same time.

2. Add or remove washers as needed to adjust tilt-way clearance to have 1/16" - 1/8" of clearance in direction 'B' shown in Figure 1.
3. Once the tilt-way clearance is set, tighten bolts to 640 ft-lbs.

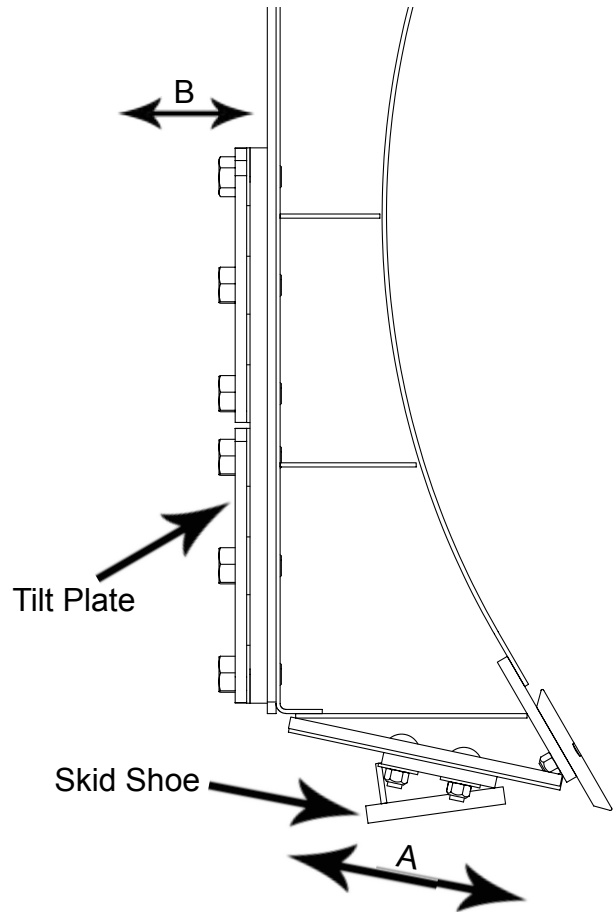

Figure 1

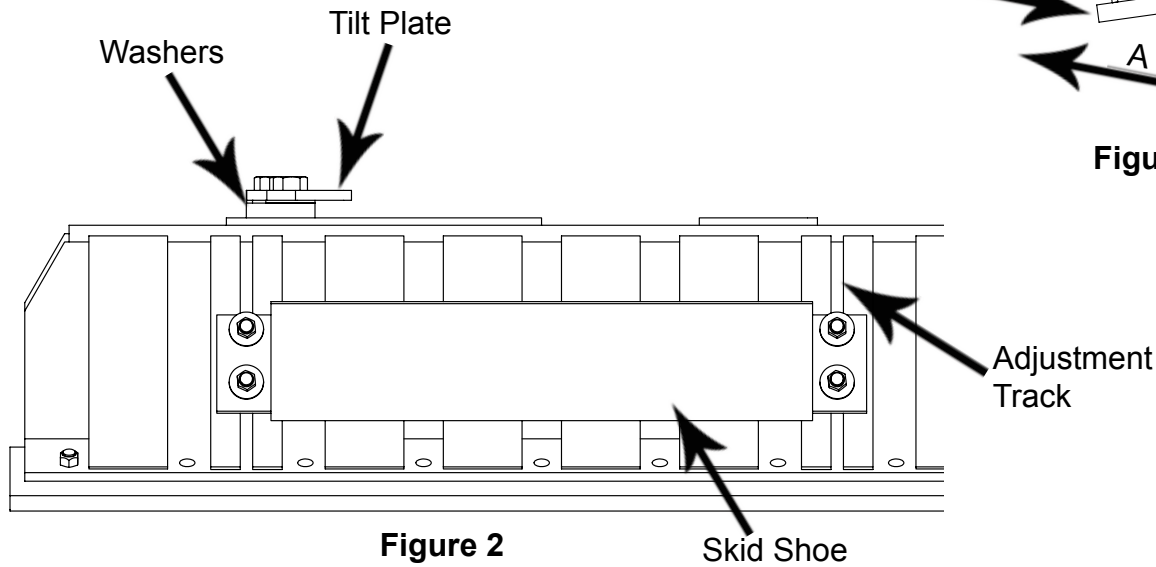
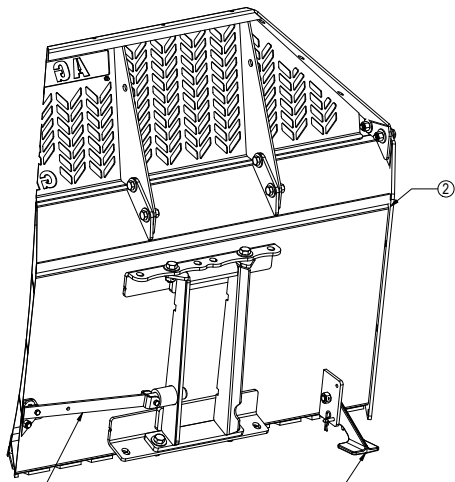
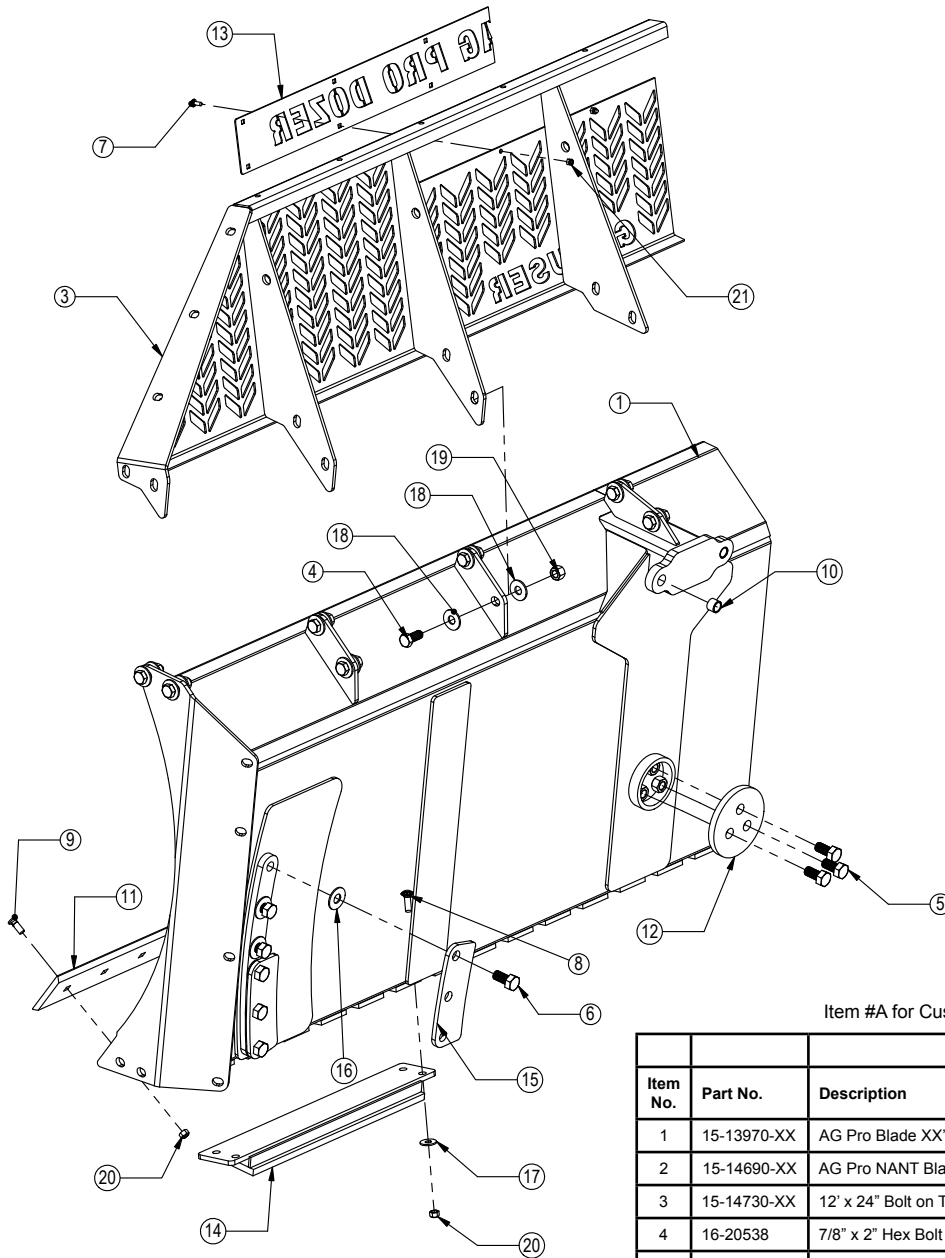

Figure 2

Angle / Tilt Function Abbreviation Key

HAHT	Hydraulic Angle - Hydraulic Tilt	6-Way
HANT	Hydraulic Angle - No Tilt	4-Way
NAHT	No Angle - Hydraulic Tilt	4-Way
NANT	No Angle - No Tilt	2-Way



Refer to Pages 12-13 for Quick Attach System.

Refer to Page 10 for Blade Stand Parts

Item #A for Custom Name Plate and Item #B for AG Pro Name Plate

Item No.	Part No.	Description	Blade Length				
			12'	14'	16'	18'	20'
1	15-13970-XX	AG Pro Blade XX' - Slant Top	1	1	1	1	1
2	15-14690-XX	AG Pro NANT Blade XX' - Slant Top	1	1	1	1	1
3	15-14730-XX	12' x 24" Bolt on Top Extension - Slant Top	1	1	1	1	1
4	16-20538	7/8" x 2" Hex Bolt Gr 8 NC	14	14	18	18	22
5	16-20558	1" x 2" Hex Bolt Gr 8 NC	3	3	3	3	3
6	16-20562	1" x 3" Hex Bolt Gr 8 NC	12	12	12	12	12
7	16-21064	3/8" x 1" Carriage Bolt Gr 5 NC	8	8	8	8	8
8	16-21188	5/8" x 2" Carriage Bolt Gr 5 NC	8	8	8	8	8
9	16-21666	5/8" x 1-3/4" Plow Bolt Gr 5 NC	24	28	32	36	40
10	19-7774	1" x 1" Spring Bushing	2	2	2	2	2
11	29-7950-6	6'- 5/8" x 6" Double Bevel Cutting Edge	2	-	-	3	2
11	29-7950-7	7'- 5/8" x 6" Double Bevel Cutting Edge	-	2	-	-	-
11	29-7950-8	8'- 5/8" x 6" Double Bevel Cutting Edge	-	-	2	-	1
12	44-3749	Backdrag Brace Plate	1	1	1	1	1
13A	44-14830	Custom Name Plate	1	1	1	1	1
13B	44-15150	AG Pro Name Plate	1	1	1	1	1
14	50-8725	Skid Shoe 33"	2	2	2	2	2
15	52-8204	Tilt Plate	4	4	4	4	4
16	57-20749	1" Flat Washer	12	12	12	12	12
17	57-20816	5/8" Flat Washer Grade 8 (USS)	8	8	8	8	8
18	57-20818	7/8" Flat Washer Heavy Duty Grade 8 (USS)	28	28	36	36	44
19	70-20598	7/8" Hex Nut Gr 8 NC	14	14	18	18	22
20	70-20646	5/8" Hex Top Lock Nut Gr 5 NC	32	36	40	44	48
21	70-20622	3/8" Flange Nut	8	8	8	8	8

Hydraulic Instructions

Prior to operating the blade, bleed all air out of the hydraulic system. Start with the furthest location away from the remote until all air is out.

Hydraulic Angle System Operating Instructions

If your Grouser blade was purchased with the Hydraulic Angle Option, you will have the ability to angle the blade 30 degrees left or right. To achieve these angles, the two cylinders are designed to operate independently of each other through an electric diverter valve. To angle the blade to the left, actuate the tractor hydraulic control lever in the cab with the diverter valve un-powered. To angle the blade to the right, apply power to the diverter valve and then actuate the tractor hydraulic control lever.

2-Lever Angle System Operating Instructions

If your Grouser blade was purchased with the 2-Lever Hydraulic Angle Option, you will have the ability to angle the blade 30 degrees left or right. To achieve these angles, the two cylinders are designed to operate independently of each other with the use of 2 tractor hydraulic control levers and a safety relief valve. To angle the blade to the left or right, actuate the tractor hydraulic control lever corresponding to the left or right cylinder.

The safety relief valve allows the cylinder to retract if its internal pressure becomes excessive. With this safety feature in place, when either cylinder reaches the end of its stroke, the safety relief valve will reroute pressure to the opposite cylinder causing it to extend. If this occurs, refer to the Relief Valve Instructions below for possible adjustments. Only one cylinder should be extended when angled dozing.

Relief Valve Instructions

Set the safety relief valve at a higher pressure than tractor: To increase the pressure of the relief valve, install a 0-5,000 psi pressure gauge into the base end of right angle cylinder (see page 26). Loosen the jam nut on the safety valve and tighten the Allen screw 1/2 turn. Next, extend the right side cylinder out until the safety valve activates, while the safety valve is in function, record the pressure reading on the gauge. Continue to tighten the Allen screw in 1/2 turn increments and record the pressure until a high enough relief setting is obtained. **Do not exceed the 3,000-psi operating pressure of the cylinders.** Tighten the jam nut and remove the gauge. Follow the same steps for the left side cylinder.

Automatic lever release: In certain newer model tractors, the hydraulic control lever will automatically release and instantly stop oil flow once the end of the stroke is reached.

(Continued on next page)

CAUTION: Do not bypass the safety relief valve and plumb each cylinder to separate valves on the tractor.

To ensure proper use and life of equipment, it is recommended to have both cylinders closed for straight ahead dozing and only one cylinder partially or fully extended for angled dozing as shown in the diagrams below. **If the angle system is not used correctly, frame damage may occur.** Some damaged frames can be repaired, please contact Grouser Products for repair instructions if needed.

Please contact Grouser Products with any questions by:
Phone - 701-282-7710 or 800-747-6182; Fax - 701-282-8131

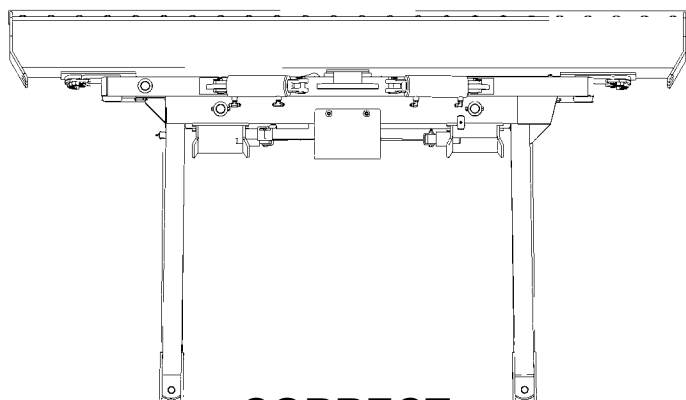

CORRECT

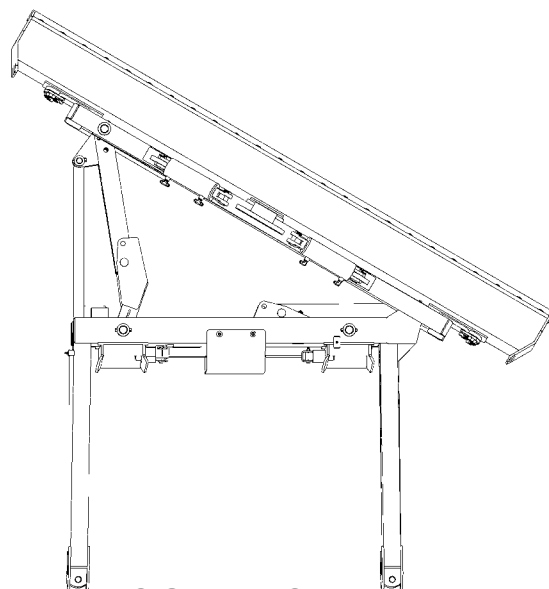

CORRECT
(Left or Right)

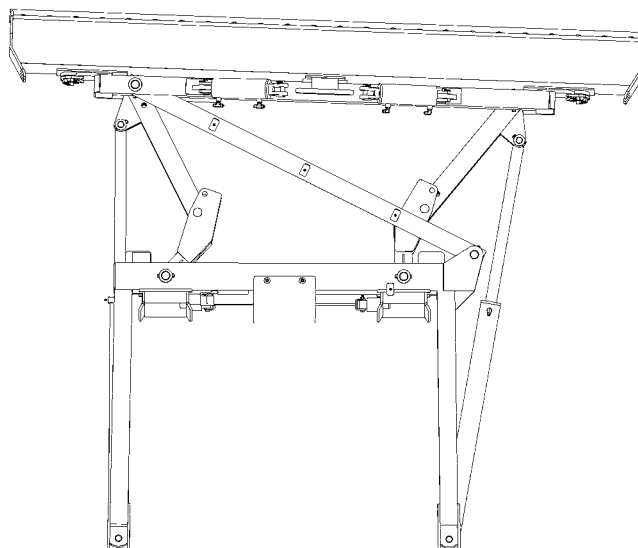

INCORRECT

Unpacking Components

Unstrap and remove the lift frame, hoses, top arms, and any boxes of hardware from the undercarriage. If any components are missing, call Grouser.

Assembling Lift Components

Install undercarriage per the tractor specific mounting instructions. Some assembly of Lift system components is necessary. Follow the steps listed below. Refer to Page 9 for the correct hardware and orientation of parts.

1. Remove all pins on each side of the undercarriage.
2. Position the lift frame between the two plates on both sides of the undercarriage.
3. Align the lift frame to the bottom holes of the undercarriage and attach with the proper pins and hardware.
4. Lift the end of the cylinders up and attach to the undercarriage with the proper pins and hardware.
5. Attach the top arms to the top of the undercarriage with the proper pins and hardware.
6. Remove the male quick attaches that are in the female quicks on the blade, angle frame, or tilt frame.
7. Attach the male quick attaches to the lift frame and top arms with the proper pins and hardware.
8. If the quick couplers and coupler mount are not already attached to the left top arm, attach each of the coupler mounts to the top arms with 4 - 3/8" flange nuts. See Page 20 for proper orientation.
9. Take the lift hoses that are already attached to the furthest forward fittings on the left and right side of the undercarriage and attach them to the lift cylinders.

Note: For Step #10-15, refer to Page 20-23 for further information on hose routing and hose positions. The amount and location of the female couplers is determined by functions the blade is set up for.

10. Run the remaining hoses thru the hose loop on the top arm and attach a 90° fitting to all the hoses.
11. Install a female quick coupler onto each 90° fitting from the previous step.
12. Install each coupler into the designated hole on the coupler mount and hold them in place with the coupler retainer plate, 3/8" x 3/4" bolts and 3/8" flange nuts.
13. Take the long hoses and attach each one to their designated fitting at the center of the undercarriage.
14. Route the hoses thru the hose loops on the undercarriage.
15. Continue to route the hoses thru the tractor. Keep away from all moving parts.
16. If applicable, attach the wire harness to the bottom right hole of the coupler mount. Hold in place with a zip tie. Run the other end of the wire harness up into the cab of the tractor.
17. Locate the fused power supply. Connect the red wire to power and the black to ground. Install provided switch into an open switch hole in the right overhead console or another convenient place in the tractor. Connect the wire harness to the switch.
18. Pull the pin puller handle on the left side of the quick attach system towards the outside of the blade to open the quick attach system. Refer to Page #12-13 for further clarification on the quick attach system.
19. Tilt the male quick attaches forward slightly.
20. Drive the tractor forward slowly until the top edge of the male quick attach is under the top lip of the female quick attach already on the blade assembly.
21. Tilt the male quick attaches backward till the blade is off the ground and the female quick attaches are against the front of the male quick attaches.
22. Shut off machine and set the parking brake.
23. Move the pin puller handle on the left side of the blade assembly towards the center of the blade to lock the blade in place and use the latch to lock the handle in place. If applicable, turn up the blade stands on the blade.
24. Plug the male couplers into the female couplers on the top arm. Refer to Page #22-23 for proper coupler locations for all functions. If applicable, plug the male blade break away end of the wire harness into the female blade break away end of the wire harness on the top arm.

Initial System Startup

Start the tractor and run the blade thru all the functions. If any function does not work properly, bleeding of the system may be required. If problem still persists, call Grouser Products.

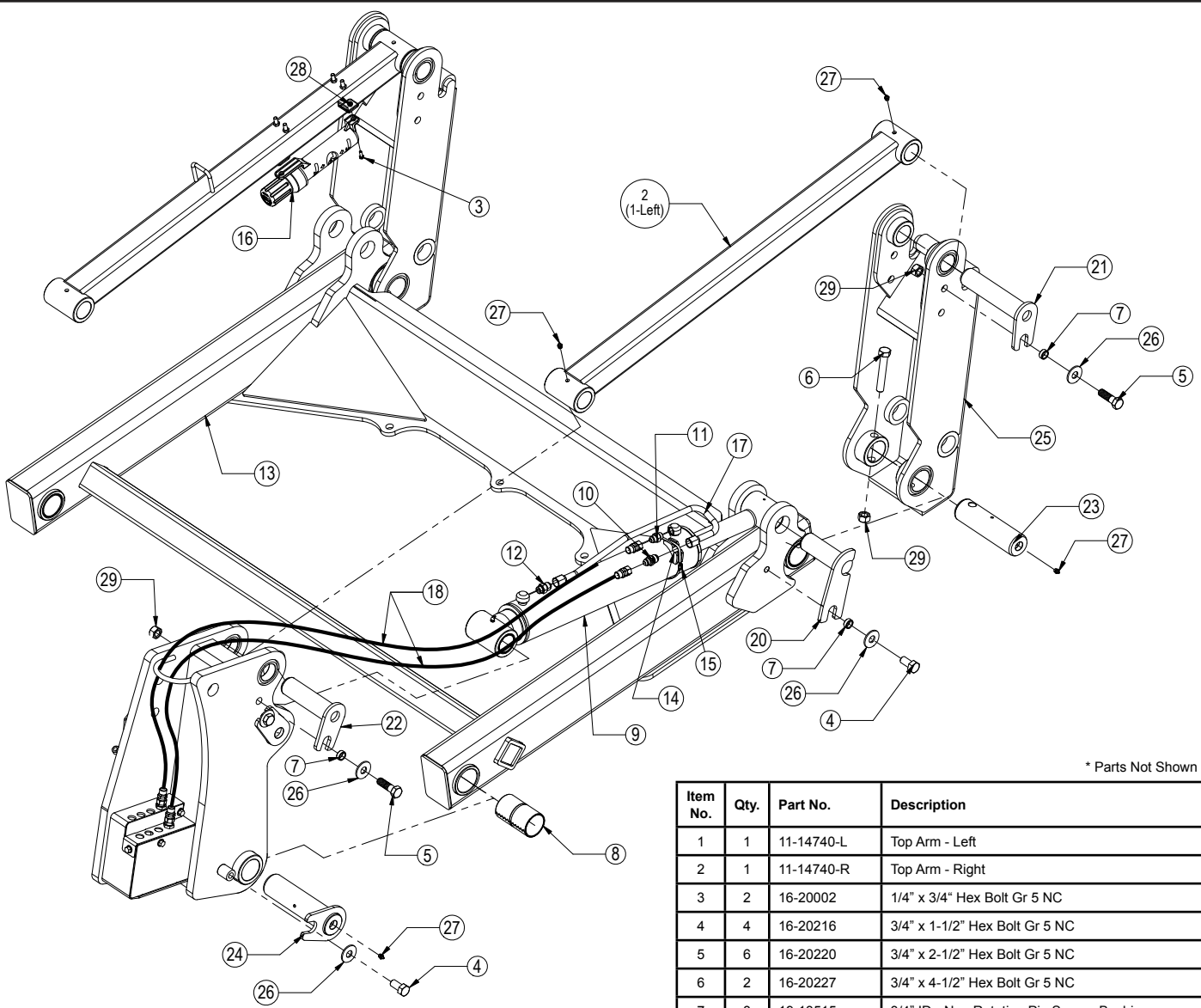

* Parts Not Shown

Item No.	Qty.	Part No.	Description
1	1	11-14740-L	Top Arm - Left
2	1	11-14740-R	Top Arm - Right
3	2	16-20002	1/4" x 3/4" Hex Bolt Gr 5 NC
4	4	16-20216	3/4" x 1-1/2" Hex Bolt Gr 5 NC
5	6	16-20220	3/4" x 2-1/2" Hex Bolt Gr 5 NC
6	2	16-20227	3/4" x 4-1/2" Hex Bolt Gr 5 NC
7	8	19-13515	3/4" ID - Non Rotating Pin Spacer Bushing
8	4	19-13525	2.75 x 2.50 x 4.75 Spring Bushing
9	2	26-34738	4x20 Long Cylinder - Bushed Tube Ends (647267)
10	2	31-11699-10-8	JIC Union (2403-10-8)
11	2	31-34040	Straight JIC x O-Ring (6400-8-8)
12	2	31-6400-10-8	Straight JIC x O-Ring (6400-10-8)
13	1	32-14960	760 Low Obstruction Lift Frame
14	2	34-12932	Cylinder Saddle (ZR518)
15	2	34-12994	Hose Clamp
16	1	34-14961	Manual Canister
17	2	35-12931	Formed Steel Line (Lift Cylinder)
18	4	35-31130	63" x 1/2" -8JIC/-8JIC Hose W/Cordura
19*	1	43-12929-L	Pin Weld - Long Ear (Lift Cyl. / Lift Frame) - Left
20	1	43-12929-R	Pin Weld - Long Ear (Lift Cyl. / Lift Frame) - Right
21	2	43-13478	Pin Weld (Top Arm / QA)
22	4	43-13482	Pin Weld (Top Arm / UC & Lift Cyl. / UC)
23	2	43-14720	Pin Weld (Lift Frame / QA)
24	2	43-14725	Pin Weld (Lift Frame / UC)
25	2	45-12175	700 Series Male Quick Attach
26	10	57-20747	3/4" Flat Washer
27	8	58-9369	Grease Zerk 1/8" NPT Straight
28	2	70-20580	1/4" Hex Nut Gr 5 NC
29	8	70-20607	3/4" Hex Center Lock Nut Gr 2 NC

NOTE: When ordering cylinder seal kits, the part number on the cylinder is needed. The number is stamped on the base end of the cylinder opposite of the hydraulic ports.

No. On Cylinder	Part No.	Description
26-34738	49-12272	Seal Kit 4" Bore x 2" Rod (647204) Nitrided Rod

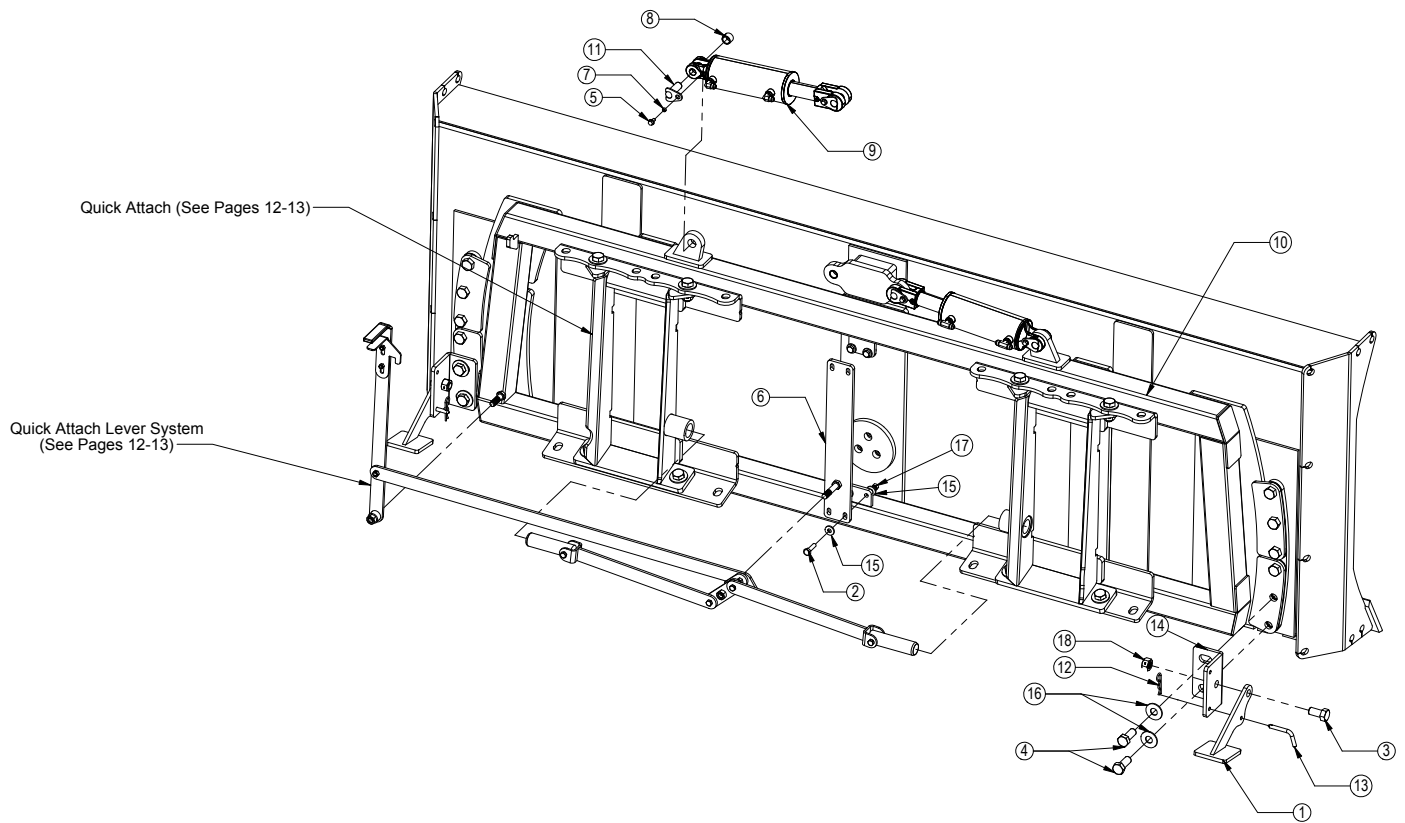

Item No.	Qty.	Part No.	Description
1	2	11-11316	AG Pro Blade Stand - Arm R2
2	4	16-20128	1/2" x 2" Hex Bolt Gr 5 NC
3	2	16-20558	1" X 2" Hex Bolt Gr 8 NC
4	4	16-20564	1" X 3-1/2" Hex Bolt Gr 8 NC
5	4	16-35C612	3/8" x 3/4" Flanged Bolt
6	1	18-14658	NAXT Center Bracket
7	4	19-13577	NR Pin Spacer Clevis End
8	2	19-7774	1" x 1" Spring Bushing
9	2	26-34711	4 x 8 Cylinder w/ Cast Clevis Ends
10	1	32-14560	NAHT Tilt Frame
11	4	43-13580	1" Clevis Bolt In Pin
12	2	43-7767	Hitch Clip Pin
13	2	43-9582	Bent Claw Pin
14	2	44-11315	AG Pro Blade Stand - Plate
15	8	57-20744	1/2" Flat Washer
16	4	57-20749	1" Flat Washer
17	4	70-20604	1/2" Hex Center Lock Nut Gr 2 NC
18	2	70-20609	1" Hex Center Lock Nut Gr 2 NC

Hoses Not Drawn To Scale

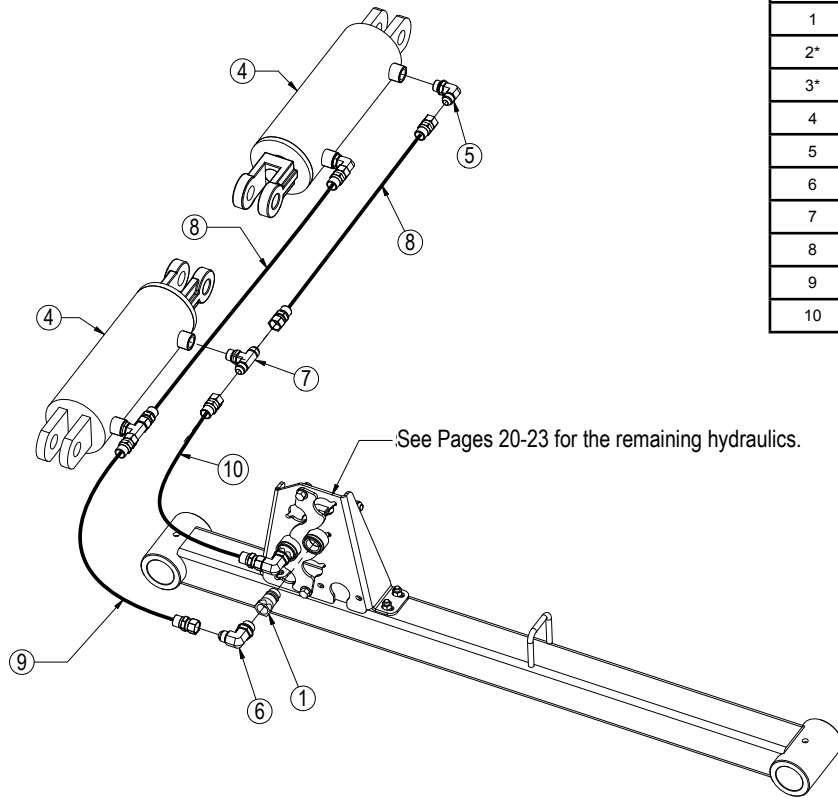

Item No.	Qty.	Part No.	Description
1	2	25-34322	Tappet Quick Coupler Male
2*	2	25-3453	Pioneer Dust Cap Tilt (Green)
3*	2	25-3454	Pioneer Dust Plug Tilt (Green)
4	2	26-34711	4 x 8 Cylinder W/ Cast Clevis Ends
5	2	31-34050	Straight Thread Elbow 90° JIC x O-Ring (6801-8-8)
6	2	31-34051	Straight Thread Elbow 90° JIC x O-Ring (6801-8-10)
7	2	31-34060	Branch Tee JIC x O-Ring (6803-8-8-8)
8	2	35-30022	39" x 3/8" -8JIC/-8JIC Hose
9	1	35-30121	35" x 1/2" -8JIC/-8JIC Hose
10	1	35-30124	45" x 1/2" -8JIC/-8JIC Hose

* Parts Not Shown

See Pages 20-23 for the remaining hydraulics.

NOTE: When ordering cylinder seal kits, the part number on the cylinder is needed. The number is stamped on the base end of the cylinder opposite of the hydraulic ports.

No. On Cylinder	Part No.	Description
26-34711	49-12271	Seal Kit 4 x 8 (647135) Nitrided Rod, Clevis Ends

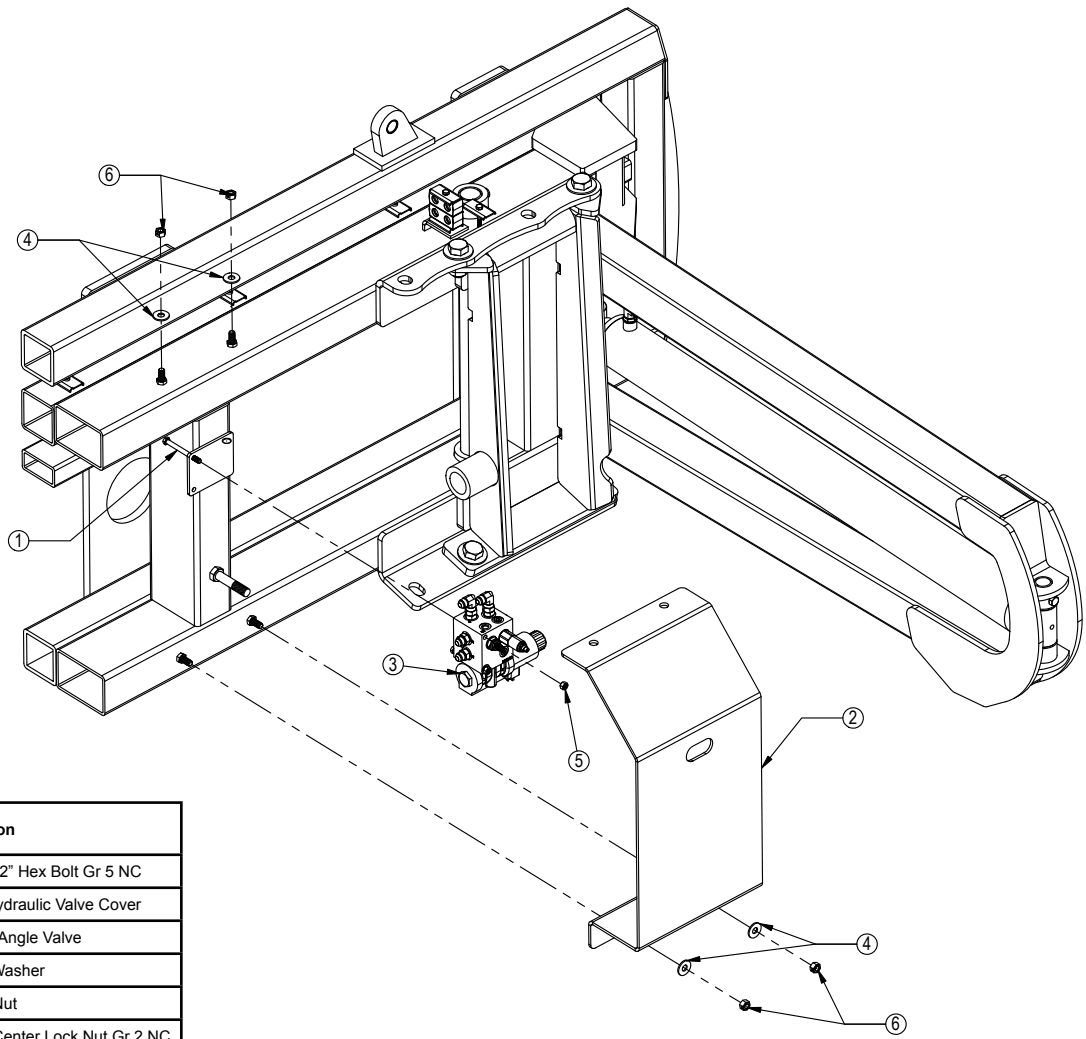

Item No.	Qty.	Part No.	Description
1	2	16-20077	3/8" x 4-1/2" Hex Bolt Gr 5 NC
2	1	18-1701	AG Pro Hydraulic Valve Cover
3	1	56-13305	Hydraulic Angle Valve
4	4	57-20744	1/2" Flat Washer
5	2	70-20582	3/8" Hex Nut
6	4	70-20604	1/2" Hex Center Lock Nut Gr 2 NC

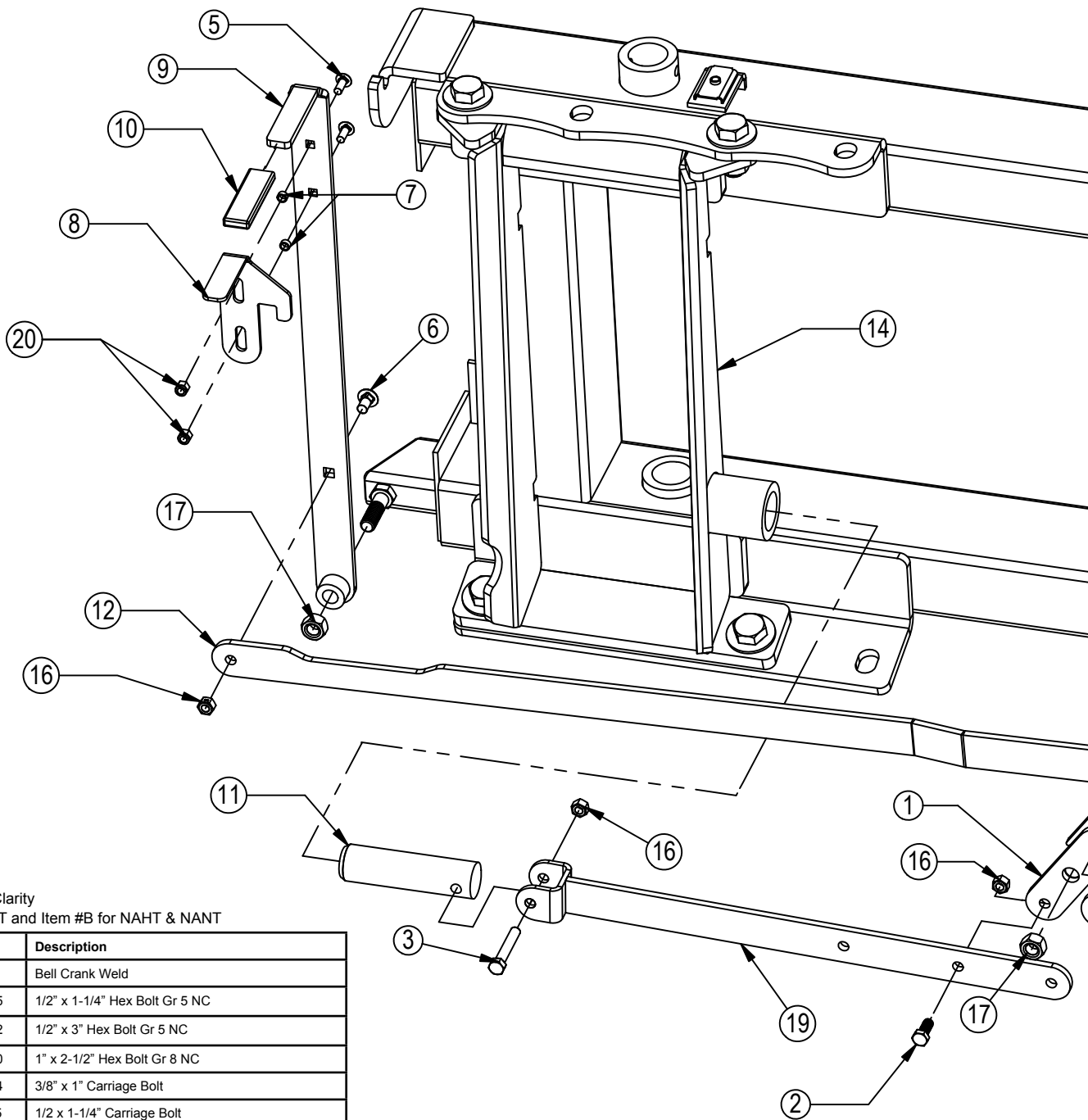

Some Parts Hidden For Clarity
 Item #A for HAHT & HANT and Item #B for NAHT & NANT

Item No.	Qty.	Part No.	Description
1	1	11-3049	Bell Crank Weld
2	3	16-20125	1/2" x 1-1/4" Hex Bolt Gr 5 NC
3	2	16-20132	1/2" x 3" Hex Bolt Gr 5 NC
4	8	16-20560	1" x 2-1/2" Hex Bolt Gr 8 NC
5	2	16-21064	3/8" x 1" Carriage Bolt
6	1	16-21125	1/2 x 1-1/4" Carriage Bolt
7	2	19-13577	NR Pin Spacer Clevis End
8	1	39-14663	AG Pro Pin Puller Latch
9	1	39-14665	AG Pro Pin Puller Handle Weld
10	1	39-3072	Handle Cover (Orange)
11	2	43-3050	QA Lock Pin
12A	1	44-14709	Pin Puller Link Plate
12B	1	44-14662	Pin Puller Link Plate
13	1	45-14710-R	AG Pro Female Vertical Bolt On Quick Attach, Right
14	1	45-14710-L	AG Pro Female Vertical Bolt On Quick Attach, Left
15	16	57-20819	1" Flat Washer Heavy Duty Gr 8 (USS)
16	6	70-20604	1/2" Hex Center Lock Nut Gr 2 NC
17	2	70-20607	3/4" Hex Center Lock Nut Gr 2 NC
18	8	70-20609	1" Hex Center Lock Nut Gr 2 NC
19	2	75-14655	AG Pro Pin Puller Link Weld
20	2	70-20622	3/8" Flange Nut

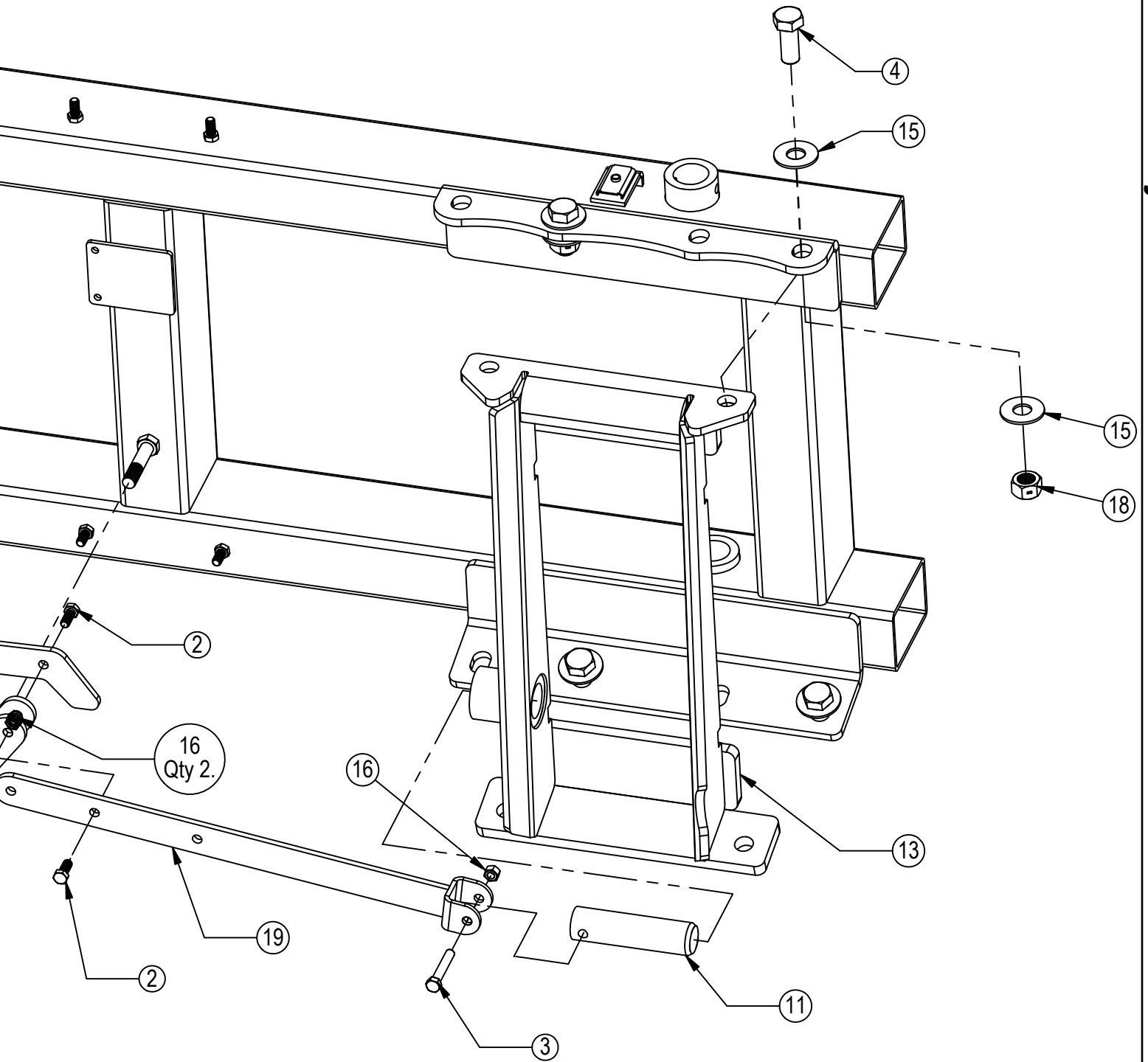

Hydraulic Angle - Hydraulic Tilt Or Hydraulic Angle - No Tilt

Item No.	Qty.	Part No.	Description
1	1	11-5055	760 Series Stabilizer Arm
2	1	11-8082	760 Series Angle Arm Right
3	1	11-9039	760 Series Angle Arm Left
4	1	14-9366	Non Tilt Bar
5	4	16-20036	5/16" x 1-1/2" Hex Bolt Gr 5 NC
6	4	16-20132	1/2" x 3" Hex Bolt Gr 5 NC
7	2	16-20424	1/2" x 3-1/2" Hex Bolt Gr 8 NC
8	3	16-20427	1/2" x 4-1/2" Hex Bolt Gr 8 NC
9	2	16-20564	1" x 3-1/2" Hex Bolt Gr 8 NC
10	4	16-35C612	3/8" x 3/4" Flanged Bolt
11	3	18-3074	Hose Hold Down Clamp
12	5	18-3075	Hose Hold Down Clamp Plate
13	2	19-7774	1" x 1" Spring Bushing
14	4	19-13577	NR Pin Spacer Clevis End
15	2	26-34711	4 x 8 Cylinder W/ Cast Clevis Ends
16	2	26-34725	4 x 43.5 Cylinder Tube Ends, Top Port
17	1	32-14700	760 Angle Frame
18	1	32-14760	760 HA Tilt Frame
19	1	43-8130	1-15/16" x 23-1/4" Pin
20	2	43-8131	1-15/16" x 31" Pin
21	1	43-8132	1-15/16" x 35-1/2" Pin
22	1	43-8133	1-15/16" x 7-1/8" Stabilizer Arm Pin

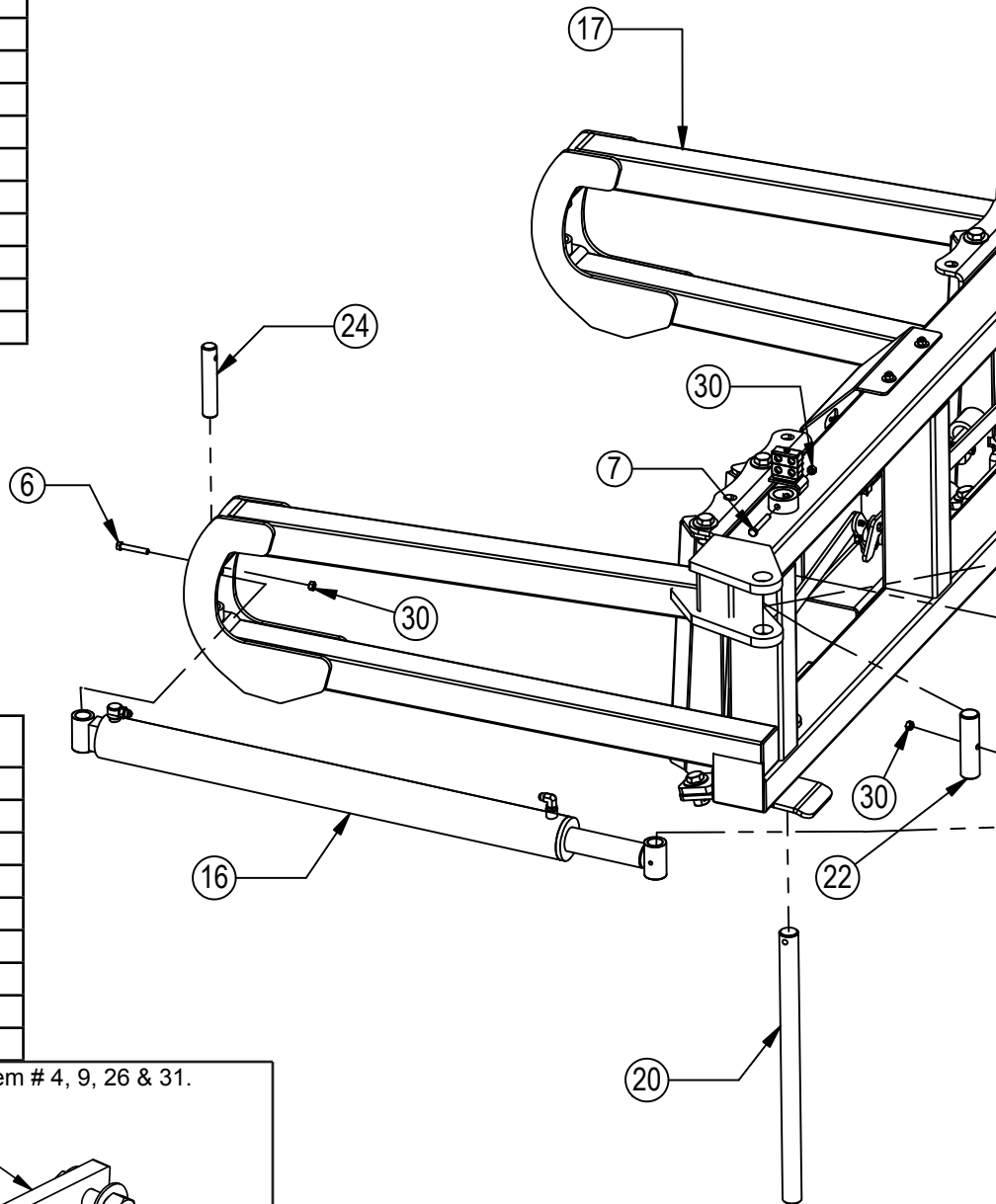

Item No.	Qty.	Part No.	Description
23	4	43-13580	1" Clevis Bolt In Pin
24	2	43-8134	1-1/2" x 8" Angle Cylinder Pin Base End
25	2	43-9352	1-1/2" x 7-1/2" Angle Cylinder Pin Rod End
26	4	57-20749	1" Flat Washer
27	2	58-9371	Grease Zerk 1/8" NPT 45°
28	6	58-9372	Grease Zerk 1/8" NPT 90°
29	1	70-20581	5/16" Hex Nut
30	9	70-20604	1/2" Hex Center Lock Nut Gr 2 NC
31	2	70-20609	1" Hex Center Lock Nut Gr 2 NC

HANT - Replace item # 10, 13, 14, 15 & 23 with item # 4, 9, 26 & 31.

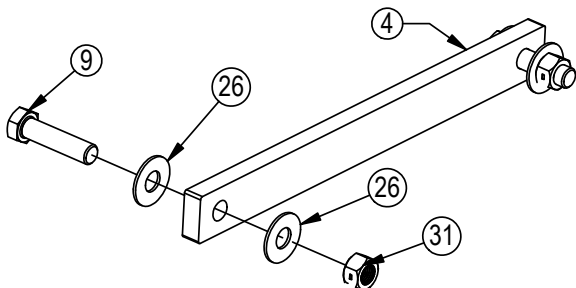

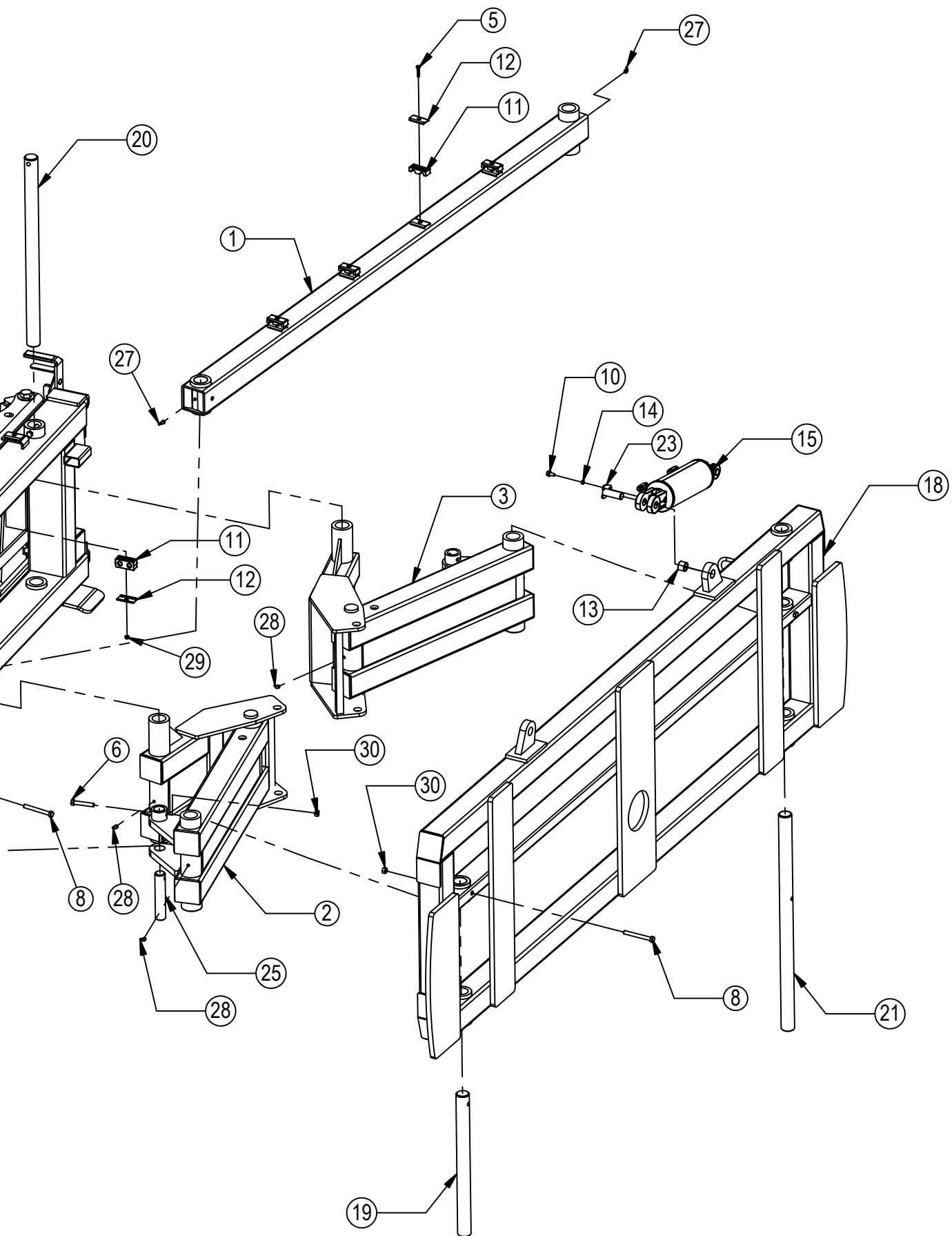

Hydraulic Angle - Hydraulic Tilt Or Hydraulic Angle - No Tilt Hose Routing

Hoses Not Drawn To Scale

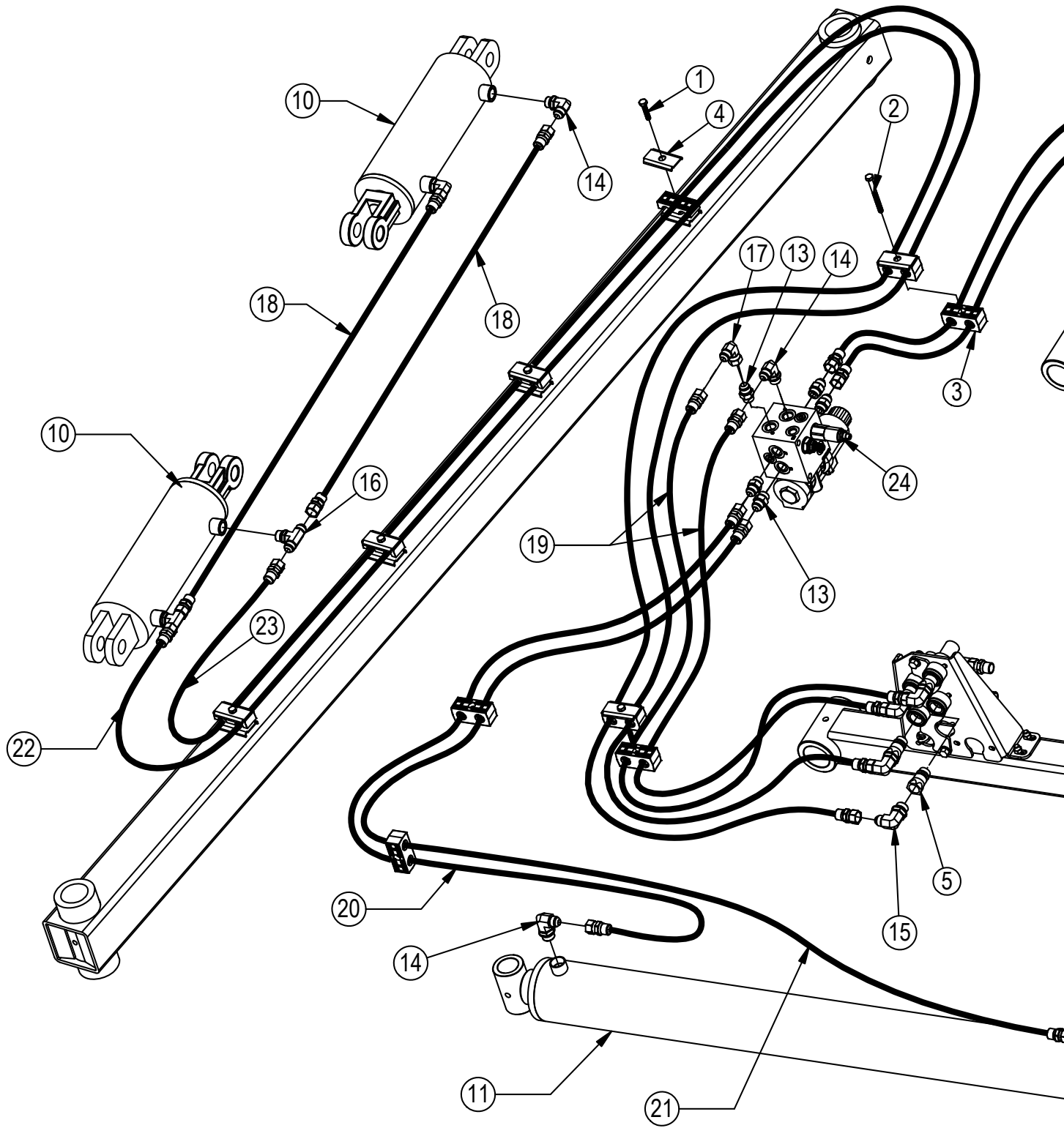

		Configuration	HAHT	HANT
Item No.	Part No.	Description	Qty.	Qty.
1	16-20036	5/16" x 1-1/2" Hex Bolt Gr 5 NC	5	3
2	16-20043	5/16" x 3-1/4" Hex Bolt Gr 5 NC	2	-
3	18-3074	Hose Hold Down Clamp	8	4
4	18-3075	Hose Hold Down Clamp Plate	8	4
5	25-34322	Tappet Quick Coupler Male	4	2
6*	25-3453	Pioneer Dust Cap Tilt (Green)	2	-
7*	25-3454	Pioneer Dust Plug Tilt (Green)	2	-
8*	25-3455	Pioneer Dust Cap Angle (Red)	2	2
9*	25-3456	Pioneer Dust Plug Angle (Red)	2	2
10	26-34711	4 x 8 Cylinder W/ Cast Clevis Ends	2	-
11	26-34725	4 x 43.5 Cylinder Tube Ends, Top Port	2	2

* Parts Not Shown

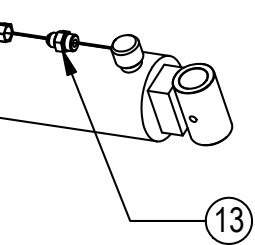
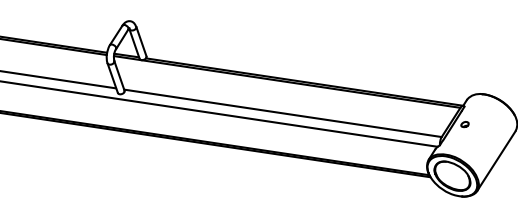
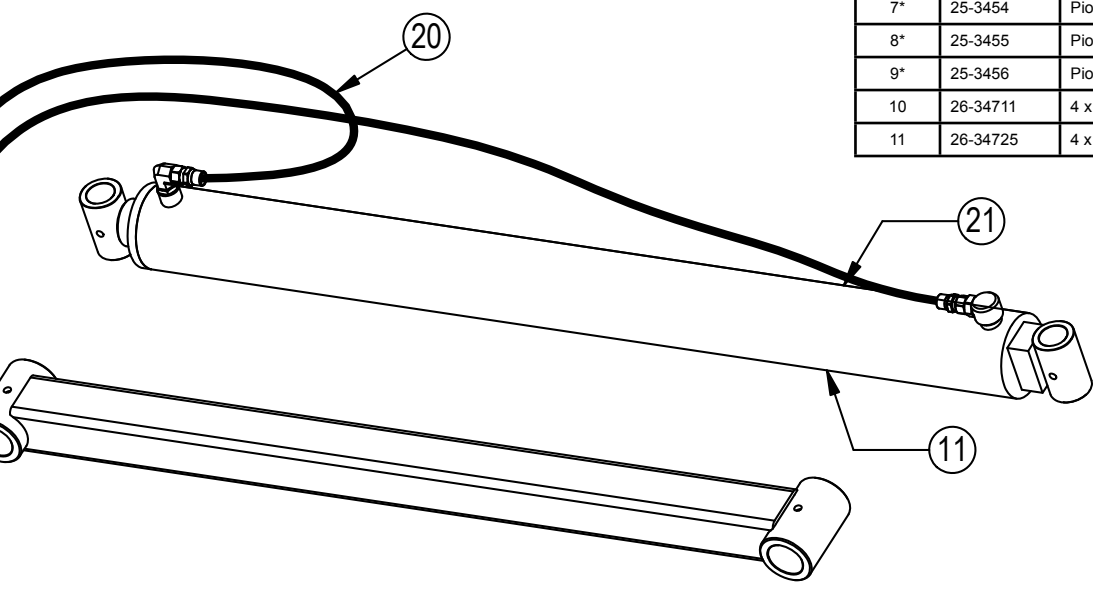

See Pages 20-23 for the remaining hydraulics and hydraulic connections.
See Page 25 for hydraulic schematics.

		Configuration	HAHT	HANT
Item No.	Part No.	Description	Qty.	Qty.
12*	31-13332	-6 SAE Breather Fitting	1	1
13	31-34040	Straight JIC x O-Ring (6400-8-8)	7	7
14	31-34050	Straight Thread Elbow 90° JIC x O-Ring (6801-8-8)	5	3
15	31-34051	Straight Thread Elbow 90° JIC x O-Ring (6801-8-10)	4	2
16	31-34060	Branch Tee JIC x O-Ring (6803-8-8-8)	2	-
17	31-34100	Swivel Nut Elbow 90° JIC (6500-8-8)	1	1
18	35-30022	39" x 3/8" -8JIC/-8JIC Hose	2	-
19	35-30130	63" x 1/2" -8JIC/-8JIC Hose	2	2
20	35-30134	75" x 1/2" -8JIC/-8JIC Hose	2	2
21	35-30145	108" x 1/2" -8JIC/-8JIC Hose	2	2
22	35-30153	205" x 1/2" -8JIC/-8JIC Hose	1	-
23	35-30156	215" x 1/2" -8JIC/-8JIC Hose	1	-
24	56-13305	Hydraulic Angle Valve	1	1
25*	70-20581	5/16" Hex Nut NC	1	1

NOTE: When ordering cylinder seal kits, the part number on the cylinder is needed. The number is stamped on the base end of the cylinder opposite of the hydraulic ports.

No. On Cylinder	Part No.	Description
26-34711	49-12271	Seal Kit 4 x 8 (647135) Nitrided Rod, Clevis Ends
26-34725	49-12274	Seal Kit 4 x 43.5 (647210) Nitrided Rod

Hydraulic Angle - 2 Lever System Hose Routing

Hoses Not Drawn To Scale

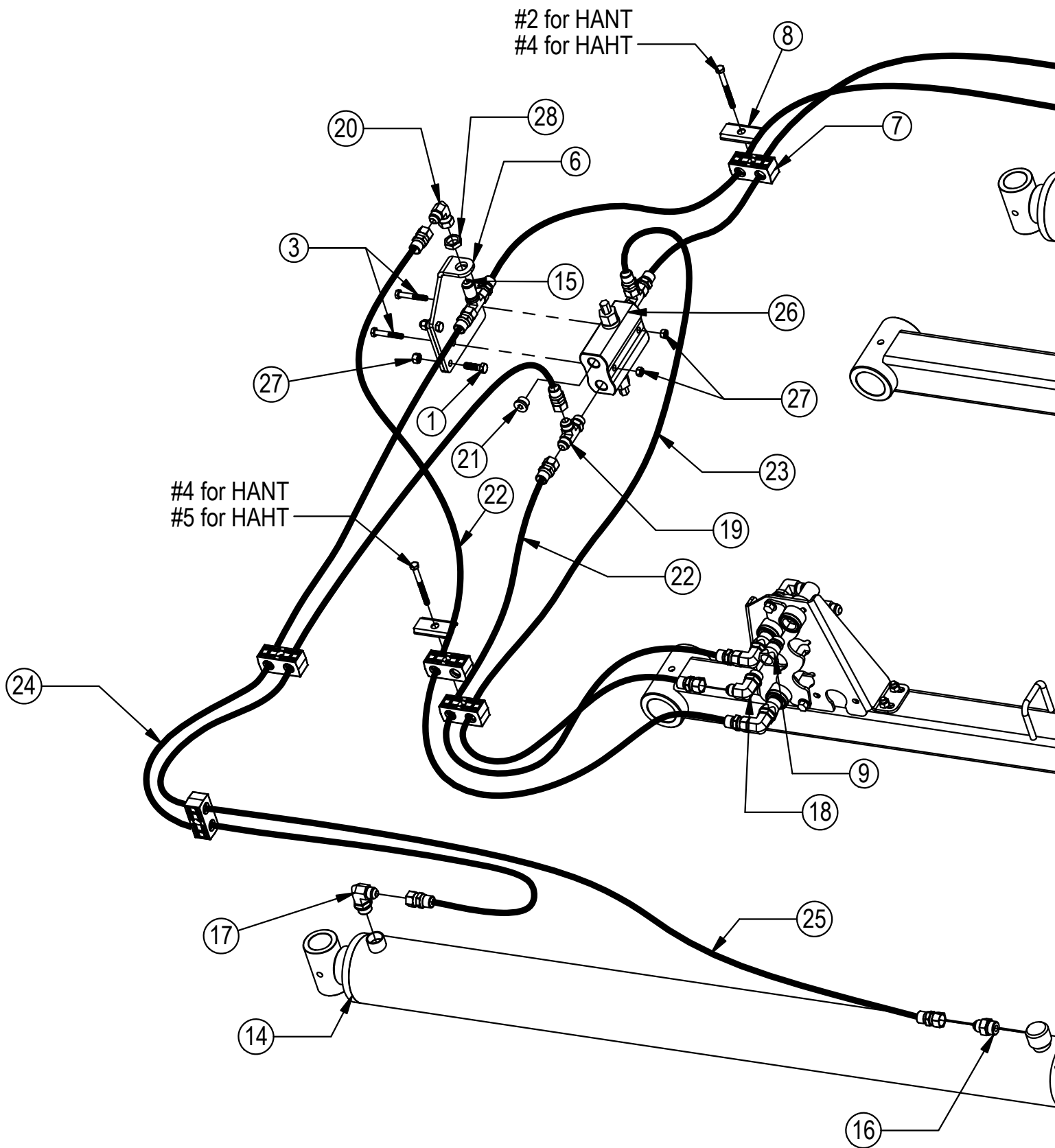

Item No.	Qty.	Part No.	Description
1	2	16-20034	5/16" x 1" Hex Bolt Gr 5 NC
2*	1	16-20036	5/16" x 1-1/2" Hex Bolt Gr 5 NC
3	2	16-20040	5/16" x 2-1/2" Hex Bolt Gr 5 NC
4	1	16-20043	5/16" x 3-1/4" Hex Bolt Gr 5 NC
5	1	16-20048	5/16" x 5" Hex Bolt Gr 5 NC
6	1	18-14695	Bracket, Relief Valve
7	5	18-3074	Hose Hold Down Clamp
8	4	18-3075	Hose Hold Down Clamp Plate
9	3	25-34322	Tappet Quick Coupler Male
10*	1	25-3401	Pioneer Dust Cap Left Angle (Yellow)
11*	1	25-3402	Pioneer Dust Plug Left Angle (Yellow)
12*	2	25-3455	Pioneer Dust Cap Right Angle (Red)

* Parts Not Shown

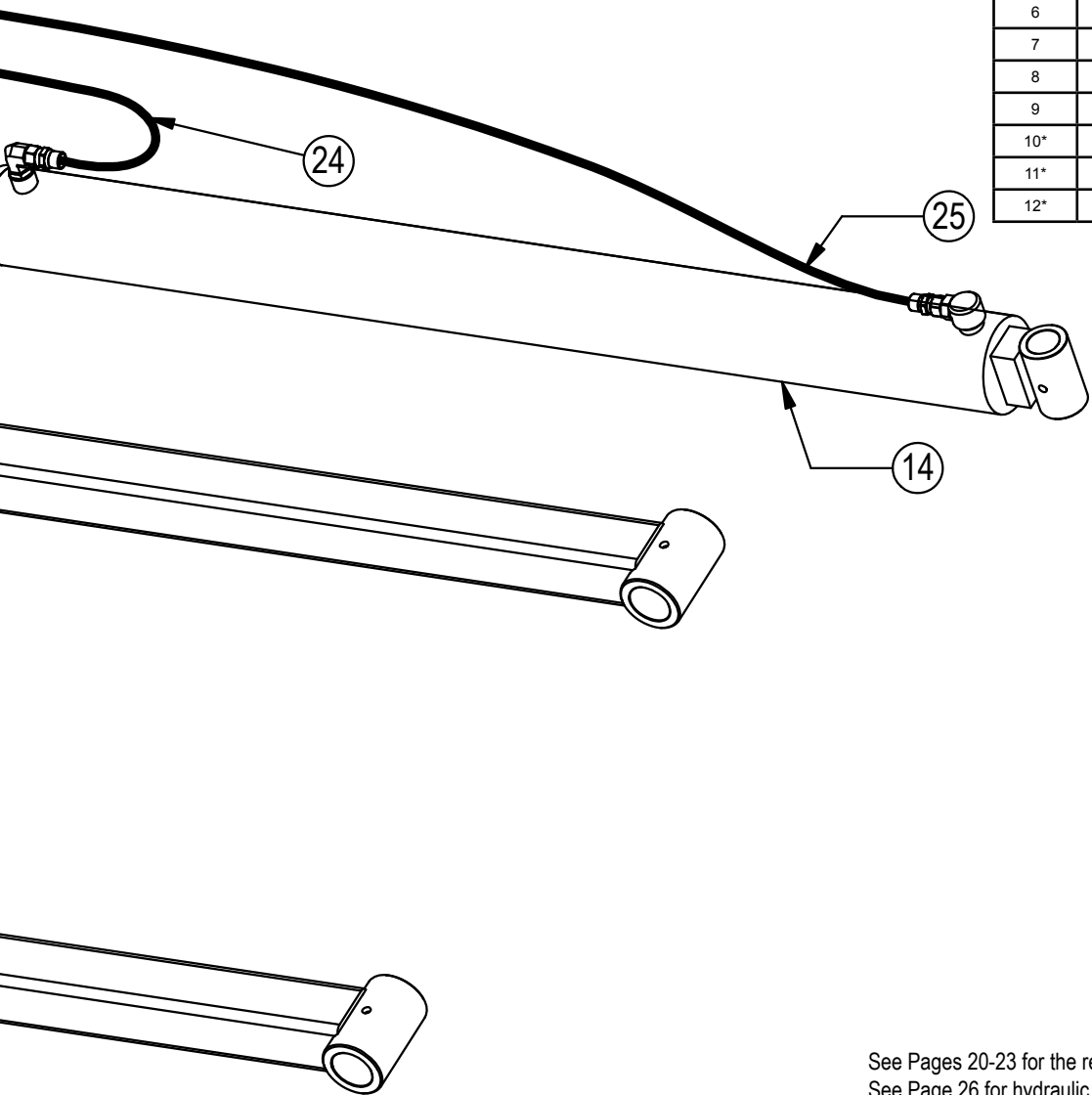

See Pages 20-23 for the remaining hydraulics and hydraulic connections.
See Page 26 for hydraulic schematics.

Item No.	Qty.	Part No.	Description
13*	2	25-3456	Pioneer Dust Plug Right Angle (Red)
14	2	26-34725	4 x 43.5 Cylinder Tube Ends, Top Port
15	1	31-34020	Bulkhead Branch Tee JIC (2703-8-8)
16	2	31-34040	Straight JIC x O-Ring (6400-8-8)
17	2	31-34050	Straight Thread Elbow 90° JIC x O-Ring (6801-8-8)
18	3	31-34051	Straight Thread Elbow 90° JIC x O-Ring (6801-8-10)
19	2	31-34070	Run Tee JIC x O-Ring (6804-8-8)
20	1	31-34100	Swivel Nut Elbow 90° JIC (6500-8-8)
21	2	31-34123	Hex Socket O-Ring Plug (6409-8-8)
22	2	35-30130	63" x 1/2" -8JIC/-8JIC Hose
23	1	35-30132	69" x 1/2" -8JIC/-8JIC Hose
24	2	35-30134	75" x 1/2" -8JIC/-8JIC Hose
25	2	35-30145	108" x 1/2" -8JIC/-8JIC Hose
26	1	56-7772	Relief Valve
27	5	70-20581	5/16" Hex Nut NC
28	1	70-20807	3/4" Hex Jam Nut NF

NOTE: When ordering cylinder seal kits, the part number on the cylinder is needed. The number is stamped on the base end of the cylinder opposite of the hydraulic ports.

No. On Cylinder	Part No.	Description
26-34725	49-12274	Seal Kit 4 x 43.5 (647210) Nitrided Rod

Hoses Not Drawn To Scale

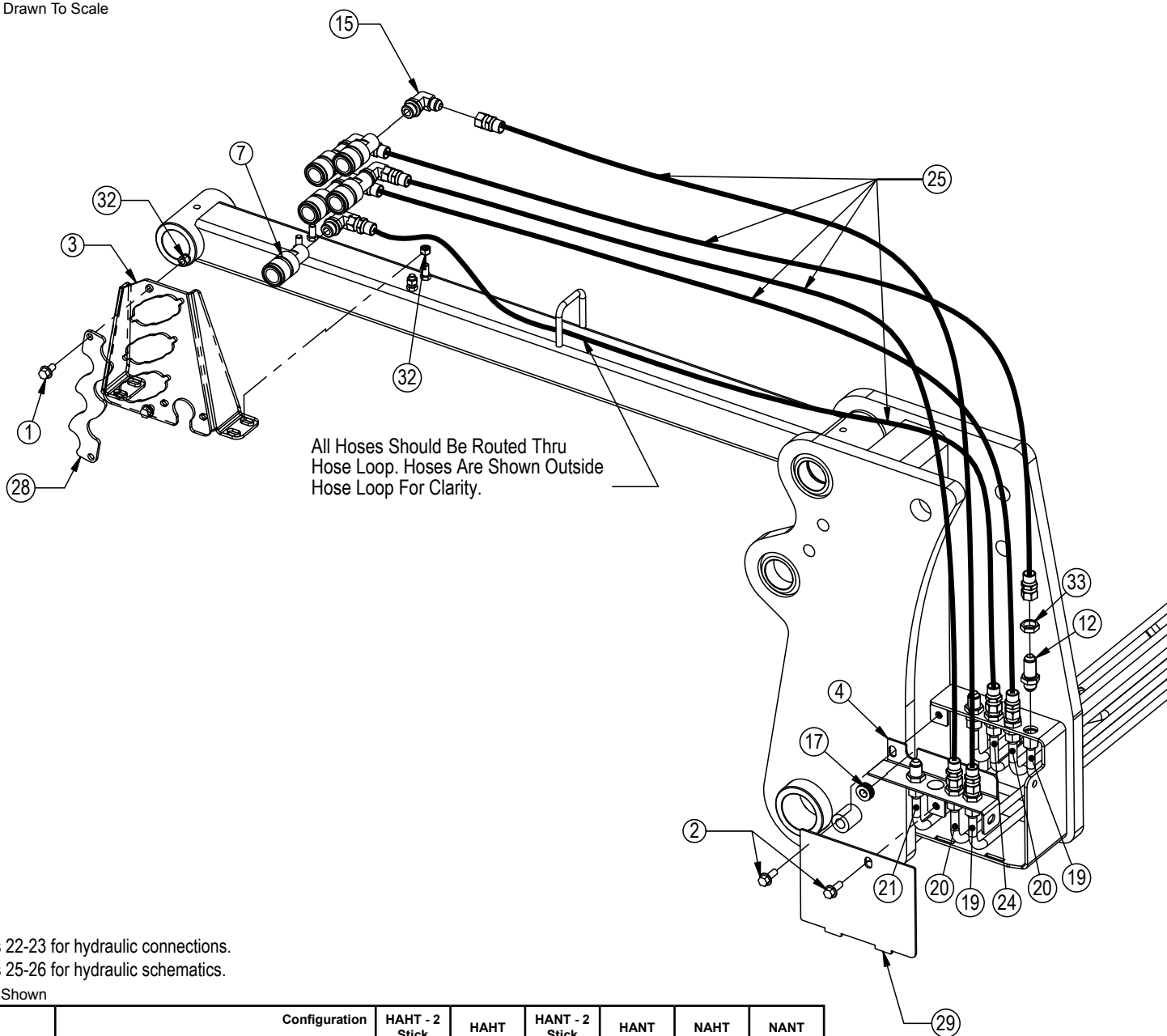

See Pages 22-23 for hydraulic connections.

See Pages 25-26 for hydraulic schematics.

* Parts Not Shown

Item No.	Part No.	Description	Configuration	HAHT - 2	HAHT	HANT - 2	HANT	NAHT	NANT
				Stick		Stick			
			Qty.	Qty.	Qty.	Qty.	Qty.	Qty.	Qty.
1	16-35C612	3/8" x 3/4" Flanged Bolt	2	2	2	2	2	2	-
2	16-35C616	3/8" x 1" Flanged Bolt	6	6	6	6	6	6	6
3	18-14737	700 Series Female Coupler Mount - Universal	1	1	1	1	1	1	-
4	18-15580-L	Bracket, Hydraulic Cover - Top Left	1	1	1	1	1	1	1
5	18-15580-R	Bracket, Hydraulic Cover - Top Right	1	1	1	1	1	1	1
6	25-34322	Tappet Quick Coupler Male	8	6	6	4	4	4	2
7	25-34321	Tappet Quick Coupler Female	5	4	3	2	2	2	-
8*	25-3401	Pioneer Dust Cap Left Angle (Yellow)	2	-	2	-	-	-	-
9*	25-3453	Pioneer Dust Cap Tilt (Green)	2	2	-	-	2	-	-
10*	25-3455	Pioneer Dust Cap Right Angle (Red)	2	2	2	2	-	-	-
11*	25-3457	Pioneer Dust Cap Lift (Orange)	2	2	2	2	2	2	2
12	31-34000	Bulkhead Union JIC (2700-8-8)	14	12	10	8	8	8	4
13	31-34090	Swivel Nut Run Tee JIC (6602-8-8-8)	1	-	1	-	-	-	-
14	31-34030	Bulkhead Run Tee JIC (2704-8-8-8)	2	2	2	2	2	2	2
15	31-34051	Straight Thread Elbow 90° JIC x O-Ring (6801-8-10)	13	10	9	6	6	6	2
16	31-34100	Swivel Nut Elbow 90° JIC (6500-8-8)	2	2	2	2	2	2	2
17	34-14826	1/2" ID Rubber Grommet	-	2	-	2	-	-	-

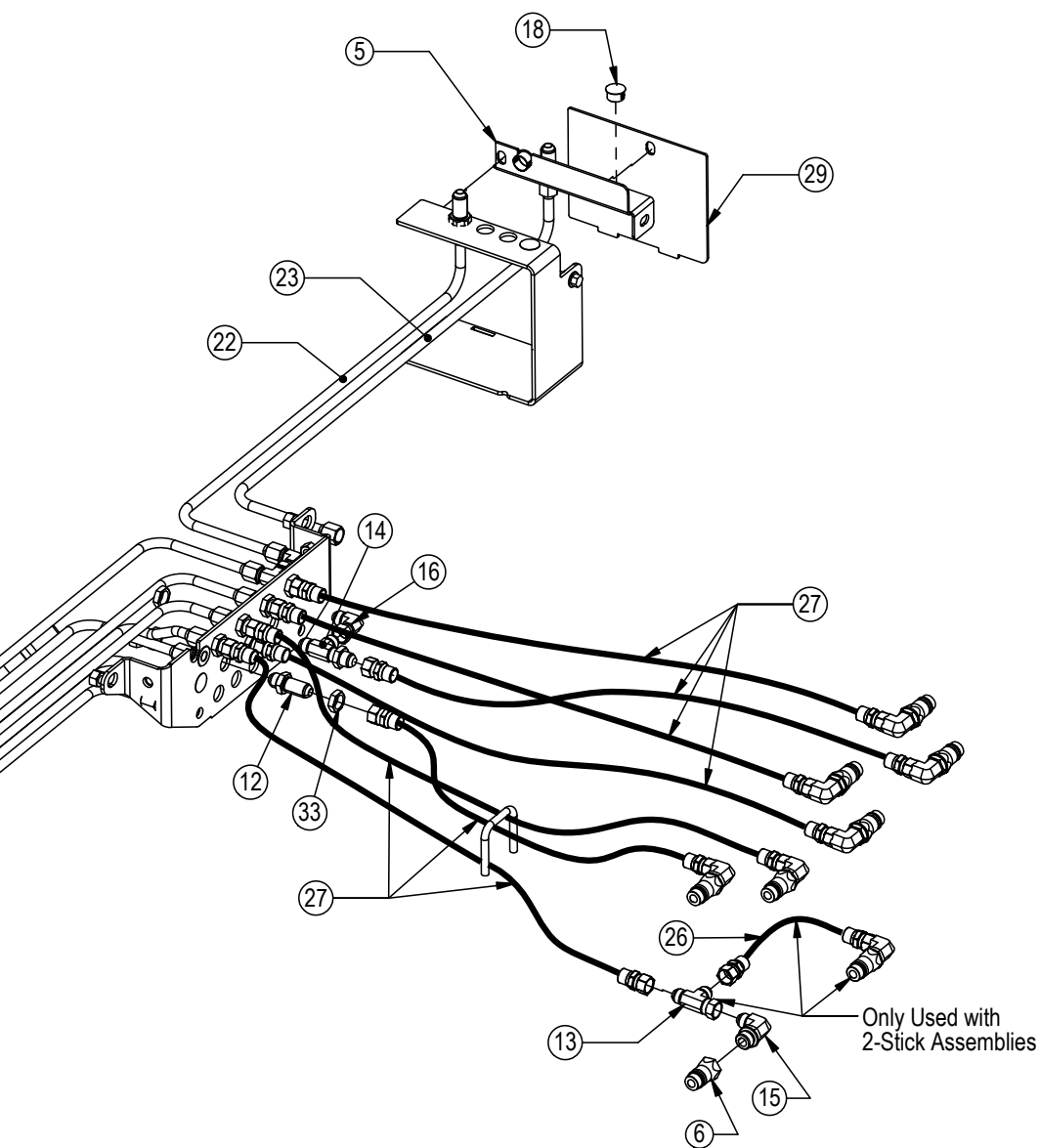

* Parts Not Shown
Item #A for Steiger Tier 4 and Item #B for JD 9R.

		Configuration	HAHT - 2 Stick	HAHT	HANT - 2 Stick	HANT	NAHT	NANT
Item No.	Part No.	Description	Qty.	Qty.	Qty.	Qty.	Qty.	Qty.
18	34-14898	Dome Plug (3044)	11	11	15	15	17	21
19	35-14351	31.63" -8 Formed Steel Line (Angle)	2	2	2	2	-	-
20	35-14352	33.88" -8 Formed Steel Line (Tilt)	2	2	-	-	2	-
21	35-14353	36.13" -8 Formed Steel Line (Left Lift)	2	2	2	2	2	2
22	35-14354	26.63" -8 Formed Steel Line (760 Right Lift)	1	1	1	1	1	1
23	35-14355	29.63" -8 Formed Steel Line (760 Right Lift)	1	1	1	1	1	1
24	35-14824	29.38" -8 Formed Steel Line (2-Stick - Left Side)	1	-	1	-	-	-
25	35-31132	69" x 1/2" -8JIC/-8JIC Hose W/Cordura	5	4	3	2	2	-
26	35-30121	35" x 1/2" -8JIC/-8JIC Hose	1	-	1	-	-	-
27A	35-30172	318" (26.5') x 1/2" -8JIC/-8JIC Hose	7	6	5	4	4	2
27B	35-30160	288" (24') x 1/2" -8JIC/-8JIC Hose	7	6	5	4	4	2
28	44-14738	700 Series Female Coupler Retainer-Universal	1	1	1	1	1	-
29	44-15120	700 Series Side Cover Plate - Left	2	2	2	2	2	2
30*	69-13352	Wire Harness - Valve to Disconnect	-	1	-	1	-	-
31*	69-1531	Wire Harness - Disconnect to Tractor	-	1	-	1	-	-
32	70-20622	3/8" Flange Hex Nut NC	6	6	6	6	6	-
33	70-20807	3/4" Hex Jam Nut	16	14	12	10	10	6

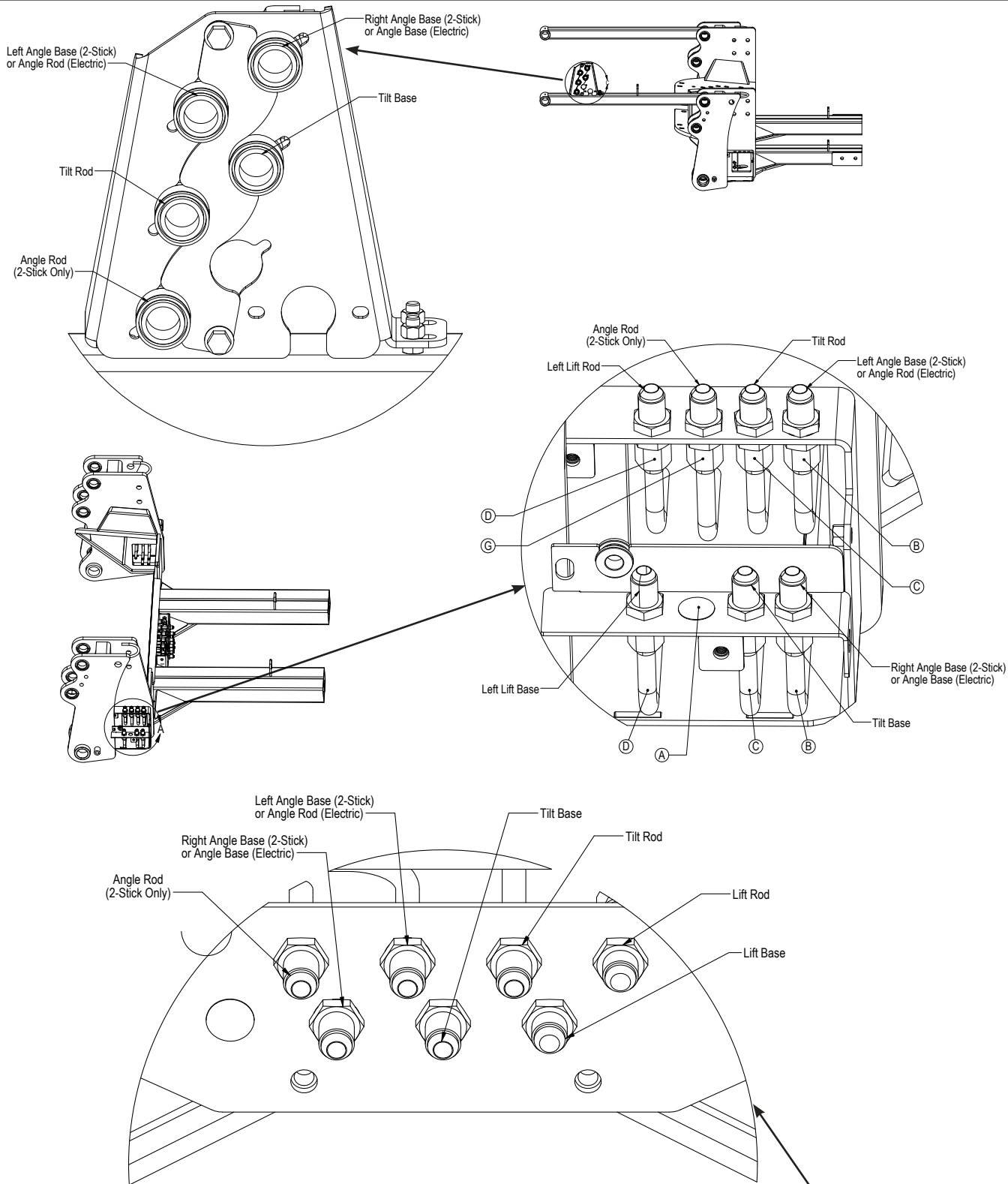

Item	Part No.	Description	Configuration					
			HAHT - 2 Stick Qty.	HAHT Qty.	HANT - 2 Stick Qty.	HANT Qty.	NAHT Qty.	NANT Qty.
A	34-14898	Dome Plug (3044)	7	7	11	11	13	17
B	35-14351	31.63" -8 Formed Steel Line (Angle)	2	2	2	2	-	-
C	35-14352	33.88" -8 Formed Steel Line (Tilt)	2	2	-	-	2	-
D	35-14353	36.13" -8 Formed Steel Line (Left Lift)	2	2	2	2	2	2
E	35-14354	26.63" -8 Formed Steel Line (760 Right Lift)	1	1	1	1	1	1
F	35-14355	29.63" -8 Formed Steel Line (760 Right Lift)	1	1	1	1	1	1
G	35-14824	29.38" -8 Formed Steel Line (2-Stick - Left Side)	1	-	1	-	-	-

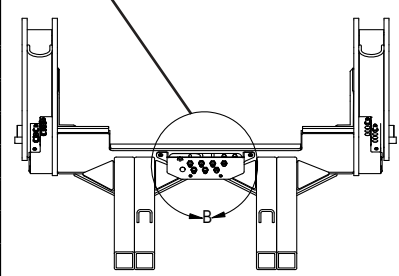

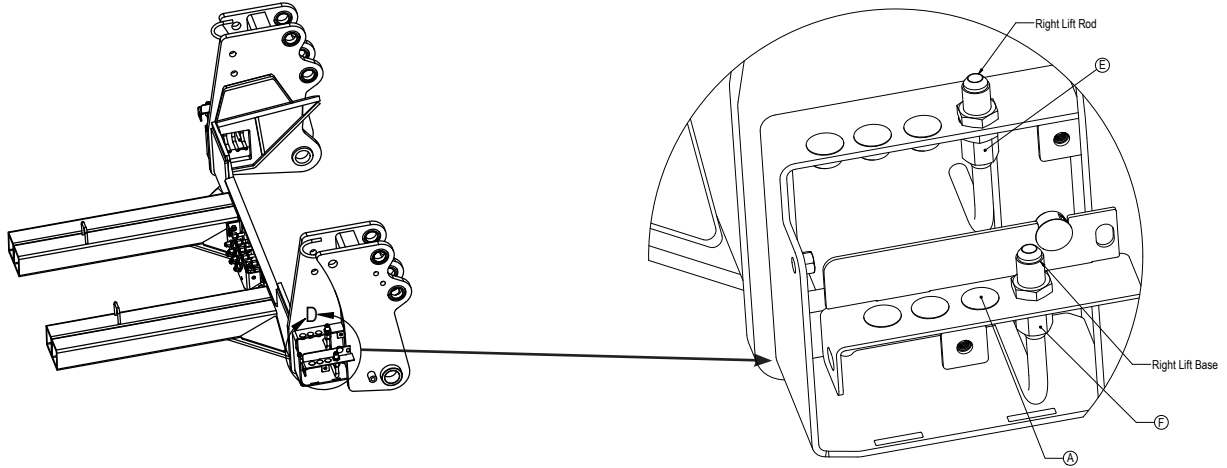

Only Left Side Shown

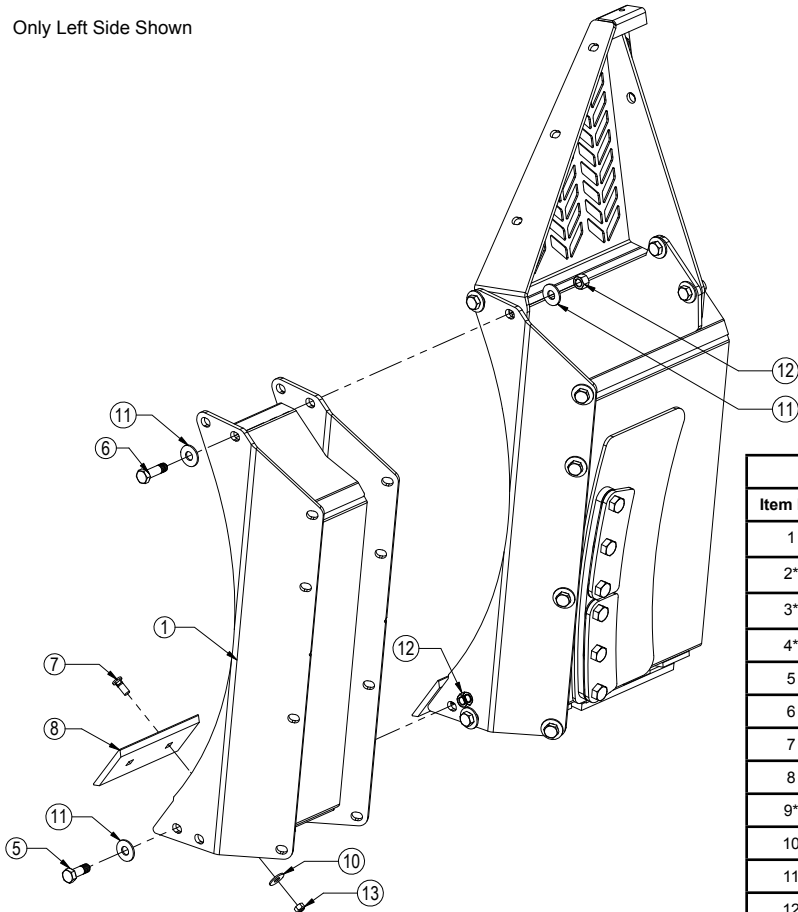

* Parts Not Shown

Item No.	Part No.	Description	End Extension Length	
			1'	2'
1	15-13990-1-L	Slant Top 1' End Extension cmb - Left	1	-
2*	15-13990-1-R	Slant Top 1' End Extension cmb - Right	1	-
3*	15-13990-2-L	Slant Top 2' End Extension cmb - Left	-	1
4*	15-13990-2-R	Slant Top 2' End Extension cmb - Right	-	1
5	16-20538	7/8" x 2" Hex Bolt Gr 8 NC	12	12
6	16-20540	7/8" x 2-1/2" Hex Bolt Gr 8 NC	4	4
7	16-21666	5/8" x 1-3/4" Plow Bolt Gr 5 NC	4	8
8	29-7950-1	1'- 5/8" x 6" Double Bevel Cutting Edge	2	-
9*	29-7950-2	2'- 5/8" x 6" Double Bevel Cutting Edge	-	2
10	57-20816	5/8" Flat Washer Grade 8 (USS)	4	8
11	57-20818	7/8" Flat Washer Heavy Duty Grade 8 (USS)	20	20
12	70-20598	7/8" Hex Nut Gr 8 NC	16	16
13	70-20646	5/8" Hex Top Lock Nut Gr 5 NC	4	8

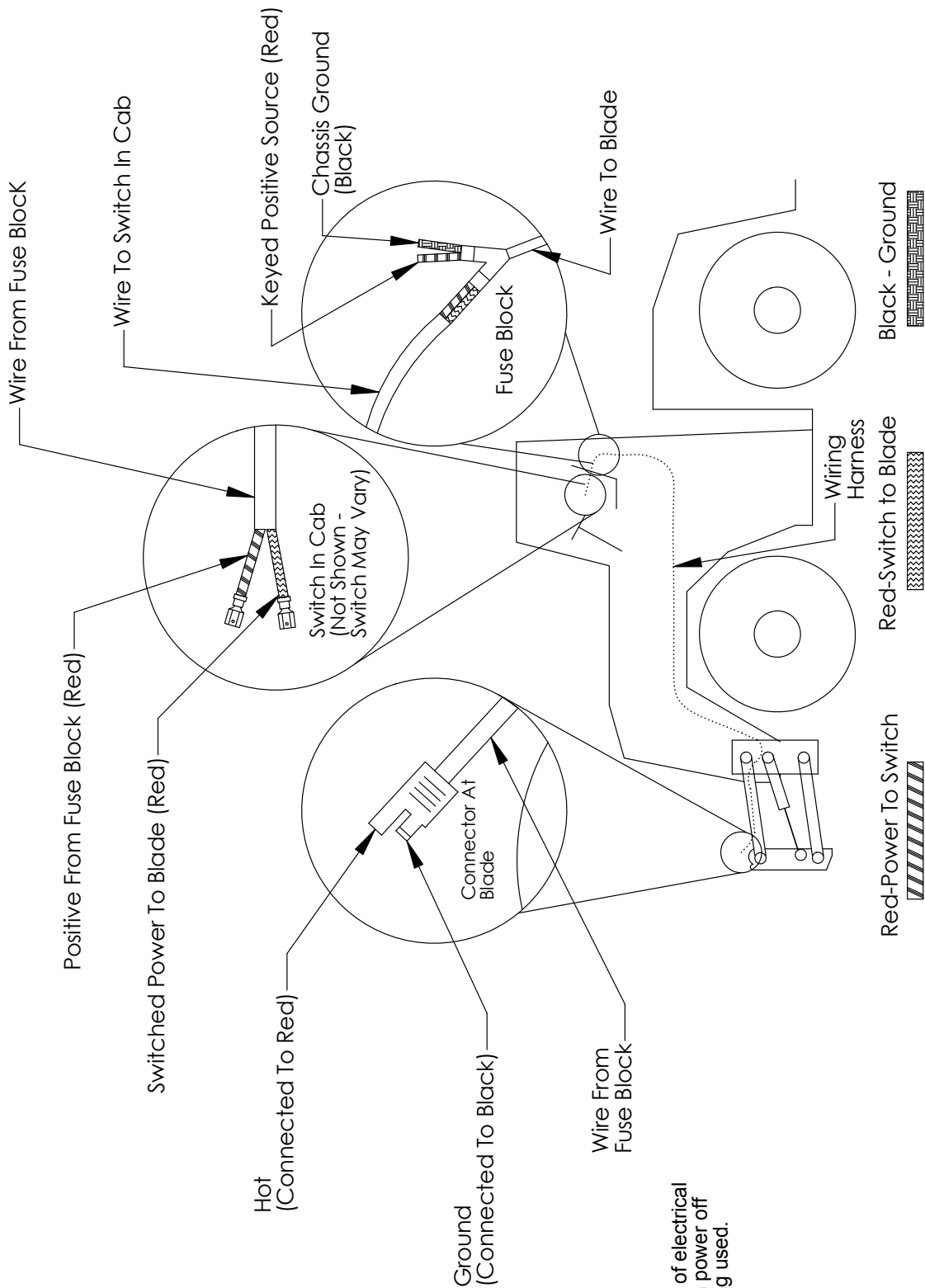

Note: To maximize life of electrical system and valve, turn power off when dozer is not being used.

Instructions

1. Locate "keyed and fused" 12 V power supply in cab of tractor.
2. Disconnect battery.
3. Connect the red wire to power and the black wire to ground.
4. Install switch in convenient place in cab.
5. Route wire harness from switch to the blade. (plug-in connector at blade)
6. Connect the switch to the wire harness.
7. Reconnect the battery.

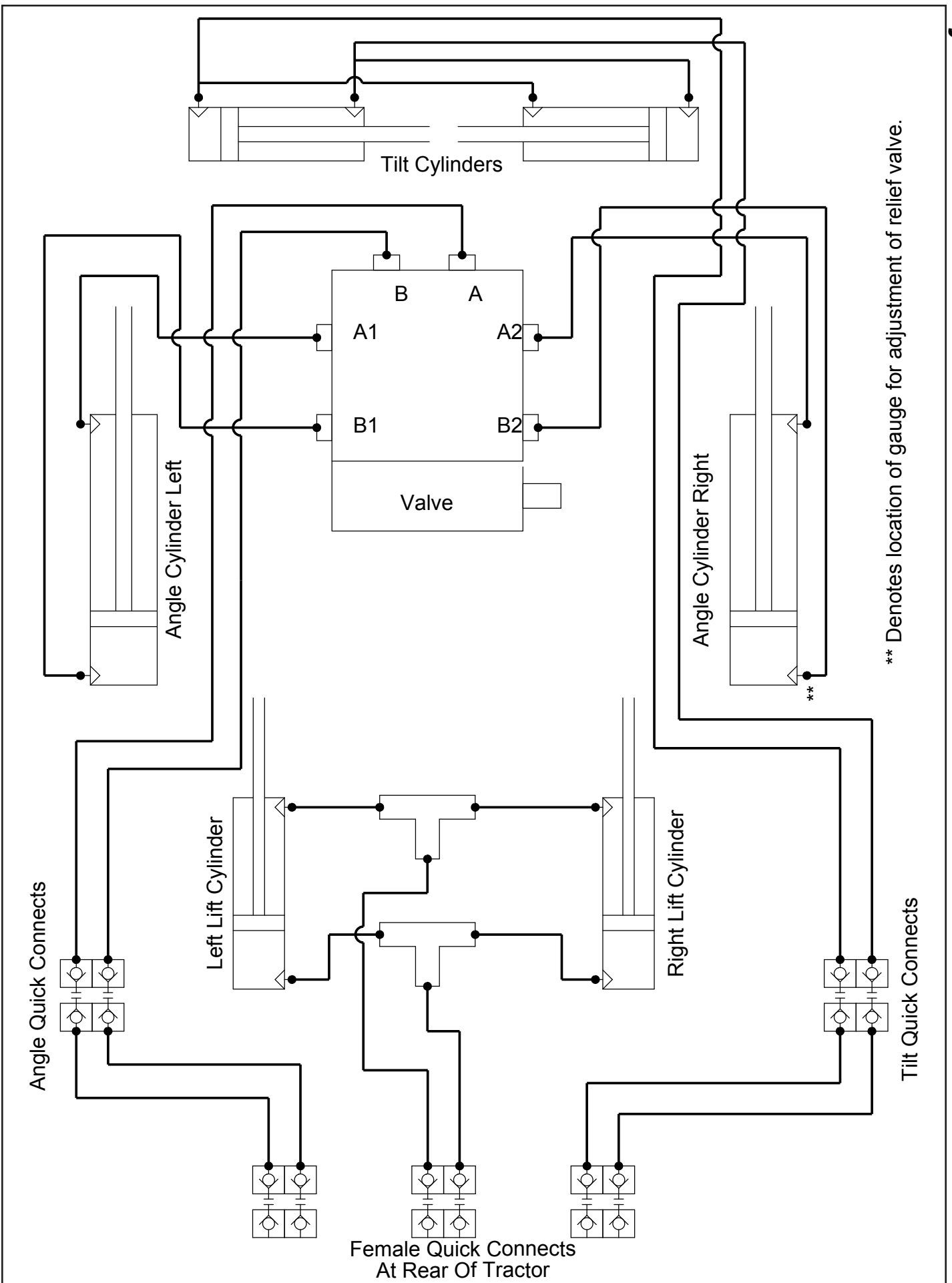

** Denotes location of gauge for adjustment of relief valve.

Tilt Quick Connects

Angle Quick Connects

Female Quick Connects
At Rear Of Tractor

2-Lever Hydraulic Schematic

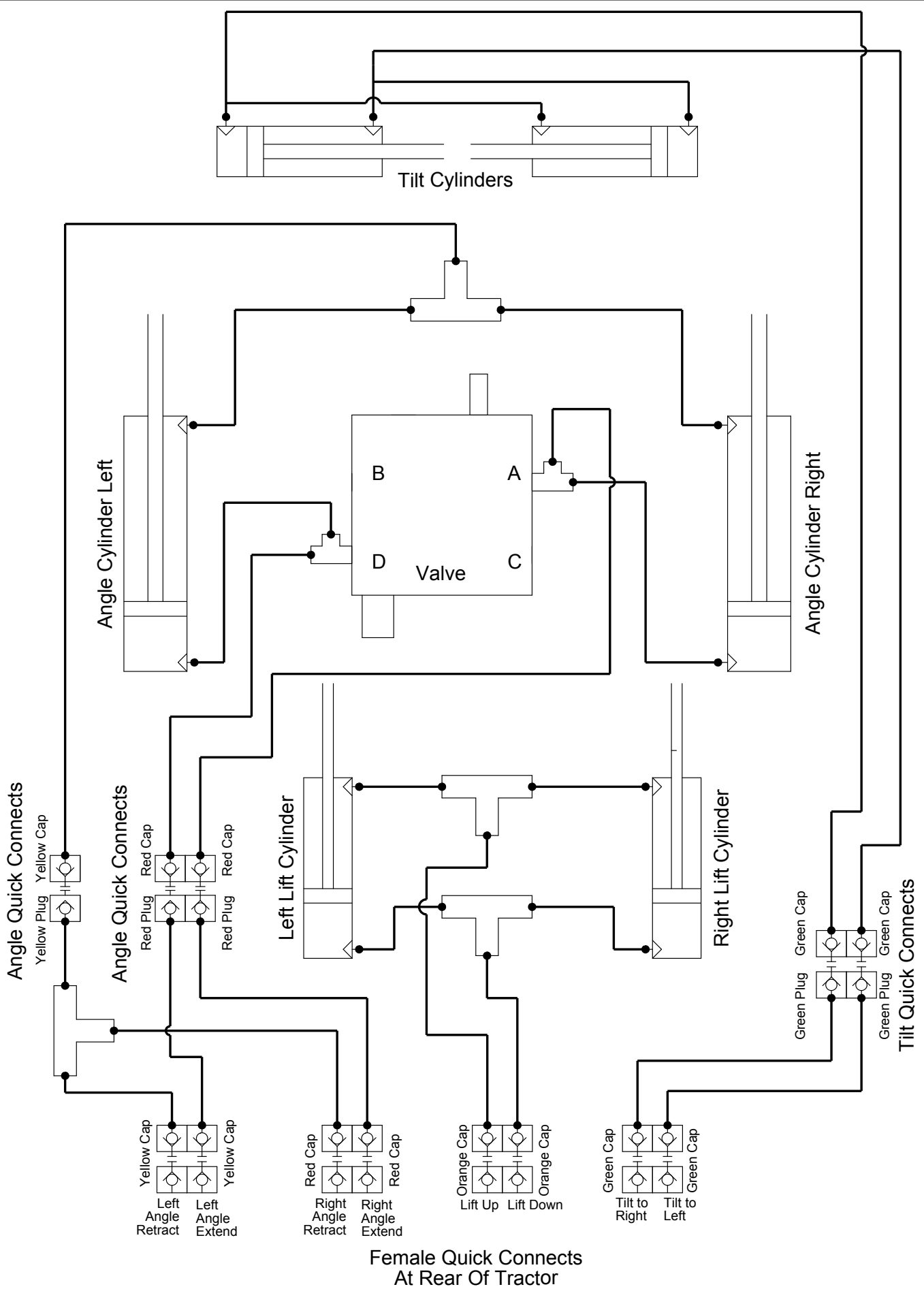

Contact Us

As always, if you have any questions about your 760 Dozer or other products made by Grouser, feel free to contact us.

Grouser Products

755 2nd Ave NW - West Fargo, ND 58078

Phone: 1-800-747-6182

Fax: 1-701-282-8131

E-mail: grouser@grouser.com

Website: www.grouser.com



Improvements

Grouser Products Inc. is continually striving to improve its products. We reserve the right to change prices, specification, or equipment at any time without notice. We also reserve the right to make improvements or changes when it becomes practical and possible to do so without incurring any obligation to make changes or additions to the equipment sold previously.

Warranty

Grouser Products warrants to the original purchaser of each item that the product be free from defects in material and workmanship under normal use and service for a period of one year. If such equipment is found to be defective within one year, it is the obligation of Grouser Products under this warranty to repair or replace (exclusive of the cost of labor and transportation), any equipment or parts, in the judgment of Grouser Products to be defective in material or workmanship.

All equipment or parts claimed to be defective in material or workmanship must be made available for inspection at the place of business of a dealer authorized to handle the equipment covered by this warranty, or, upon request by Grouser Products, shipped to the Grouser Products factory in West Fargo, North Dakota. Grouser Products shall have no obligation to bear the cost of labor or transportation in connection with replacement or repair of any such defective parts in the setup process.

This warranty covers only defects in material and workmanship. It does not cover depreciation or damage caused by normal wear, accident, improper assembly, improper adjustments, improper maintenance including lack of proper lubrication, or improper use. Therefore, Grouser Products liability under this warranty shall not be effective or actionable unless the equipment is assembled, maintained and operated in accordance with the operating instructions accompanying the equipment. Grouser Products shall have no liability if the equipment has been altered or reworked without the written authorization of Grouser Products.

Grouser Products' parts, which are furnished under this warranty and properly installed, shall be warranted to the same extent as the original parts under this warranty if, and only if, such parts are found to be defective within the original warranty period covering the original equipment.

