



# 760 - Steiger Row Trac 350-500

## Undercarriage Installation Instructions

### **Caution:**

- Always use precaution when working around any equipment.
  - Always wear safety glasses.
  - Follow tractor manufacturer's safety guidelines when installing this product.
1. Read all instructions prior to installation.
  2. Remove existing toolboxes, front weights, and tow cable holder if equipped. If a tow cable bracket was purchased from Grouser, then the tow cable can be reinstalled later.
  3. If the bottom covers (PN: 44-16590) are not factory installed, attach to U/C with 1/2" x 1-1/4" bolts (PN: 16-20125) and 1/2" flat washers (PN: 57-20744). See attached diagram for clarification.
  4. If the bulkhead bracket (PN: 18-14249 or 18-15593) is not factory installed, attach to the U/C with 2 - 1/2" x 1-1/4" bolts (PN: 16-20125) and 1/2" flat washers (PN: 57-20744). See attached diagram for clarification. See parts book for bulkhead fittings, steel lines, and hose locations.
  5. If bulkhead covers (PN: 44-14247 & 44-14246 or 44-15596) are not factory installed, verify that all hydraulics are installed correctly and then attach the covers to the U/C with 6 - 1/2" x 1-1/4" bolts (PN: 16-20125) and 1/2" flat washers (PN: 57-20744). See attached diagram for clarification.
  6. Position the undercarriage (U/C) under tractor and center on the frame of the tractor.
  7. Lift the rear of the U/C up and set the top plates at the rear of the U/C on the tractor cross member. Push the U/C back until the vertical push plates are firmly against the cross member. Lift the U/C to within 3/4" of touching the tractor frame.
  8. Insert 8 - 20mm x 90mm bolts (PN: 16-1510) with a 3/4" hardened flat washer (PN: 57-20757) on each bolt through the front holes of the tractor frame that line up with the front vertical holes of the U/C.
  9. After all bolts are through the tractor frame and U/C, attach with a 3/4" heavy washer (PN: 57-3680) and a 20mm nut (PN: 70-20872-10). Verify that the rear of the U/C is firmly against the cross member.
  10. At the rear of the undercarriage and pivot area of the tractor, hook the rear hose routing bracket to the tractor frame and bolt to the rear of the undercarriage with 1" x 3" bolts (PN: 16-20562), 1" hardened flat washers (PN: 57-20759) and 1" nuts (PN: 70-20599). The nut will fit between the plates on the brackets. See attached diagram for clarification.
  11. Center the bracket on the undercarriage and tractor as close as you can. Torque the 1" bolts to 903 ft·lbs. There can be a gap between the bracket and the undercarriage.
  12. Tight the rear vertical bolts up tight against the bottom of the tractor frame. Torque the rear vertical 1" bolts to 500-600 ft·lbs.
  13. Tighten front vertical bolts until frame is tight vertically.
  14. Attach the upper support arms (PN: 11-14240-R,L) to the U/C with 2 - 1" x 3-1/2" bolts (PN: 16-20564), 4 - 1" heavy duty flat washer (PN: 57-20819), and 2 - 1" nuts (PN: 70-20599) on each side of the U/C. See attached diagram for clarification.
  15. Attach the upper support arms to the tractor with a 1-1/4" x 3-1/2" bolt (PN: 16-20896), 4 - 1-1/4" flat washers (PN: 57-11671), and a 1-1/4" nut (PN: 70-20981) in the bottom hole on each side. See attached diagram for clarification.
  16. Install the front side tube bracket (PN: 18-16730) on each side of the undercarriage. The pins on the bracket will fit into the chain down hook on the inside of the tractor frame. Attach to the undercarriage with 2 - 3/4" x 2" bolts (PN: 16-20218), 4 - 3/4" flat washers (PN: 57-20747), and 2 - 3/4" nuts (PN: 70-20607) on each side.
  17. Once all bolts have been installed, torque the front 20mm vertical bolts to 432 ft·lbs., the 1" bolts to 903 ft·lbs., the side tube bracket 3/4" bolts to 257 ft·lbs. and the 1-1/4" bolts to 1,105 ft·lbs.
  18. Bolt the side cover (PN: 44-15575) to both sides of the undercarriage with 1/2" x 1-1/4" bolts (PN: 16-20125) and a 1/2" flat washer (PN: 57-20744) on each bolt.

19. If Tow Cable Support Assembly was purchased, guide the tow cable around the L-Shaped loop at the front of the undercarriage and place the end of the tow cable around the rod. Put the holding plate on the rod and hold all in place with a lynch pin. See attached diagram for clarification.
20. Attach the rear hose routing plate (PN: 44-17208) to the tractor frame behind the pivot point and before the drawbar. There will be 2 bolts sticking down. Attach with a 20mm nut (PN: 70-20872-10) on each side. Make sure the lip of the plate is facing towards the front of the tractor. See picture below for clarification.
21. Torque 20mm nuts to 432 ft·lbs.
22. After first 8 hours of use, re-torque all bolts.
23. Check all fasteners regularly to ensure proper operation of equipment.

**For the following steps, refer to the 2nd attached diagram for further clarification.**

24. Attach the end of the hoses that is 128" from where the cordura starts on the hoses to the front of the undercarriage where all the steel lines come to the center of the undercarriage.
25. Route all the hoses from the front of the undercarriage, thru the hose loops on the undercarriage and thru the large loop at the rear of the undercarriage. Send hoses thru the bracket at the pivot point but stay on the outside of the rods that are by the center large nut on the tractor. The hoses should be between the rods on the bracket and the inside plates of the bracket.
26. Route the hoses thru the hose routing plate that was installed in Step #20.
27. Use Zip Ties to group some hoses on the left and right side of the hose routing plate. Strap the zip Ties over the top part of the routing plate that is bolted to the tractor frame to keep the hoses towards the outside of each side of the routing plate.
28. Continue to route the hoses down the top of the drawbar to the back of the tractor where you can plug them into the tractor SCV Ports.
29. Strap the hoses to the drawbar with a set of hose holding plates (PN: 44-17245) in 2 locations. Place 1 set as close to the front of drawbar as possible and the other behind the axle before the hoses would be routed upwards to be plugged in.
30. Make sure to keep some slack in the hose between the pivot point of the tractor and the first set of hose holding plates. The hoses will move when the tractor moves and oscillates.
31. For each set of plates, use 2 - 1/2" x 5-1/2" bolts (PN: 16-20139) and 2 - 1/2" nuts (PN: 70-20604). If you have a 12-20 dozer, use 1/2" x 6" bolts (PN:16-20140) instead.
32. Tighten the 1/2" nuts so the hoses are tight and don't move. If you have the nuts as far as they go and you can't get the plates tight against the hoses, use the provided 3/4" spacers (PN:34-15528) and a 1/2" washer (PN: 57-20744) between the plates and the nuts to get everything tight against the top of the drawbar.
33. Make sure you still have some slack in the hoses by the pivot area so the hoses don't get pulled too tight when the tractor moves but don't make them too loose that they will get caught on any debris. Turn the tractor and oscillate the tractor to verify there is enough slack.



Hose Routing Plate attached with 20mm nuts. Picture doesn't show cordura on the hose but they should have cordura on them thru this pivot area of the tractor.

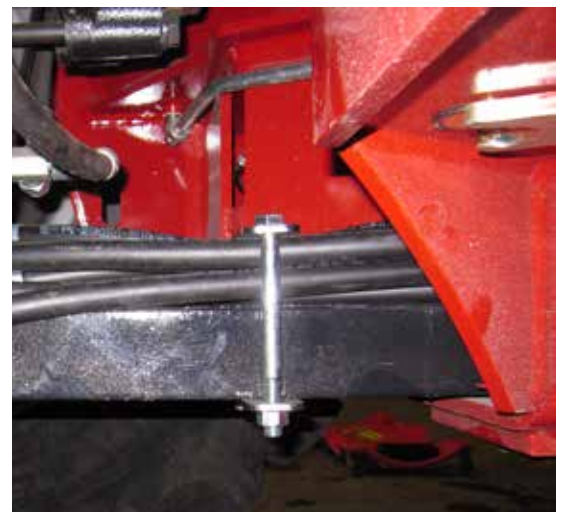

Hose holding plate in place in front of the axle.

THE INFORMATION CONTAINED IN THIS DRAWING IS THE SOLE PROPERTY OF GROUSER PRODUCTS INC ANY REPRODUCTION IN PART OR WHOLE WITHOUT THE WRITTEN PERMISSION OF GROUSER PRODUCTS INC IS PROHIBITED.

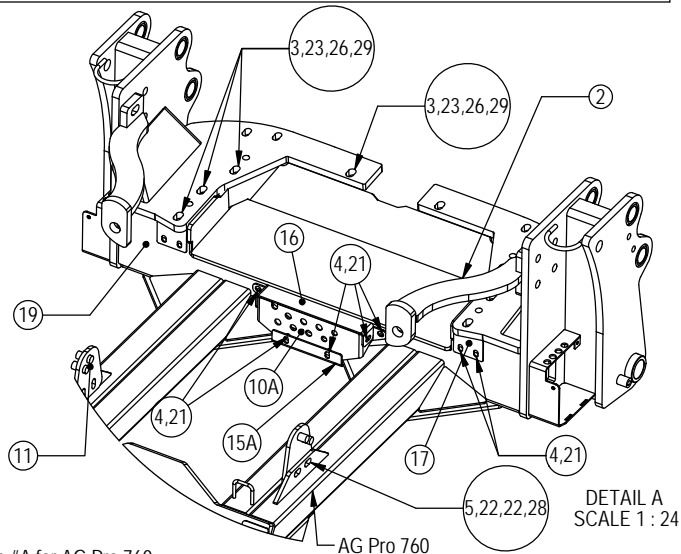

Item #A for AG Pro 760  
 Item #B for AG Pro 12-20  
 Item #C for Tow Cable Support Assy Only

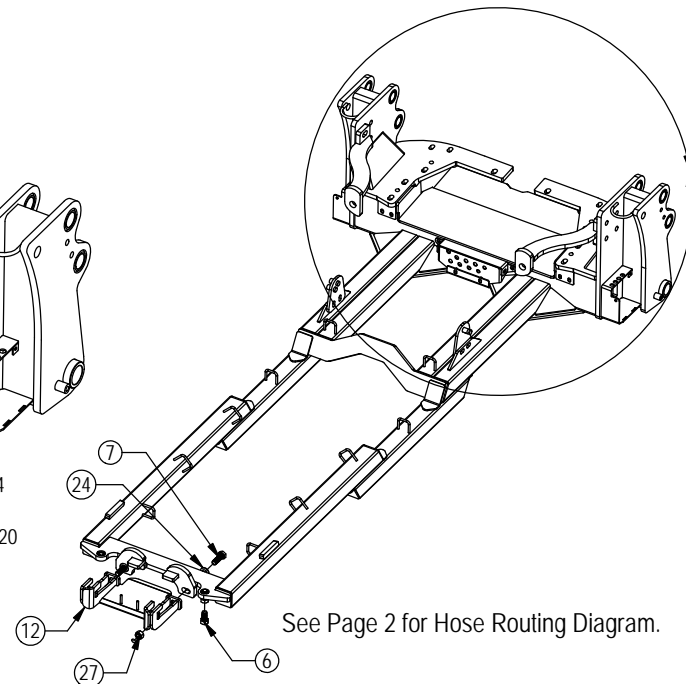
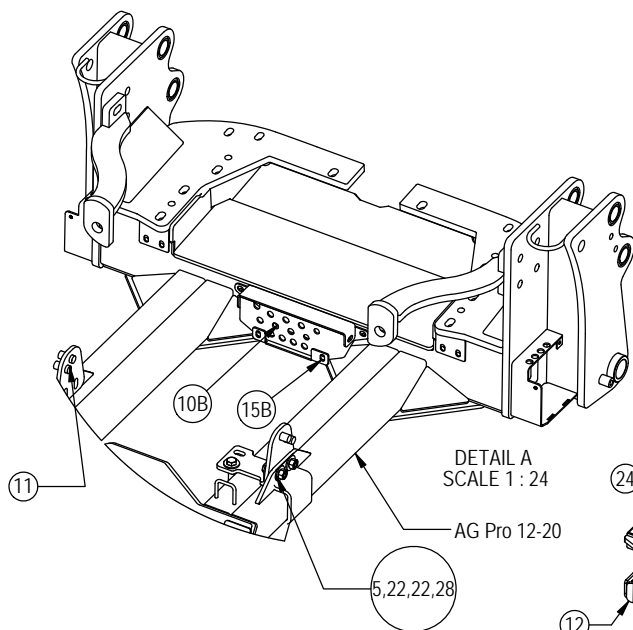

Item No.	Qty.	Part No.	Description
1	1	11-14240-L	Upper Undercarriage Support Arm Left , Steiger/TJ Row Crop
2	1	11-14240-R	Upper Undercarriage Support Arm Right, Steiger/TJ Row Crop
3	8	16-1510	20mm x 2.5mm x 90mm Metric Hex Bolt Gr 10.9 ZC
4	20	16-20125	1/2" X 1 1/4" Hex Bolt Gr 5 NC
5	4	16-20218	3/4" x 2" Hex Bolt Gr 5 NC
6	2	16-20558	1" X 2" Hex Bolt Gr 8 NC
7	2	16-20562	1" X 3" Hex Bolt Gr 8 NC
8	4	16-20564	1" X 3-1/2" Hex Bolt Gr 8 NC
9	2	16-20896	1-1/4" x 3-1/2" Hex Bolt Gr 5 NC Zinc
10A	1	18-14249	Bracket, Bulkhead - AG Pro 760
10B	1	18-15593	Bracket, Bulkhead - AG Pro 12-20 - 760
11	2	18-16730	760 CNH Front Side Tube Bracket
12	1	18-17295	760 CNH Rear UC Hose Routing Bracket
13C	1	43-9360	Lynch Pin
14	2	44-16590	Plate, Bottom Cover - Row Crop
15A	1	44-14246	Plate, Bottom Bulkhead Cover - AG Pro 760
15B	1	44-15596	Plate, Bottom Bulkhead Cover - AG Pro 12-20 - 760
16	1	44-14247	Plate, Top Bulkhead Cover - Row Crop
17	2	44-15575	Plate, Undercarriage Side Bolt Cover
18C	1	44-15585	760/770 Steiger / NH Tow Cable Holding Plate
19	1	54-17060	AG Row Trac UC
20	4	57-11671	1-1/4" Flat Washer
21	20	57-20744	1/2" Flat Washer
22	8	57-20747	3/4" Flat Washer
23	8	57-20757	3/4" Hardened Flat Washer - 1-1/2" OD
24	2	57-20759	1" SAE Hardened Flat Washer - 2" OD
25	8	57-20819	1" Flat Washer Heavy Duty Gr 8 (USS)
26	8	57-3680	2.00 OD X .75 ID x .375" Washer CZ Plated
27	6	70-20599	1" Hex Nut Gr 8 NC
28	4	70-20607	3/4" Hex Center Lock Nut NC
29	8	70-20872-10	20mm Hex Nut 2.5 Pitch Class 10 Zinc
30	2	70-20981	1-1/4" Hex Nut Gr 5 NC

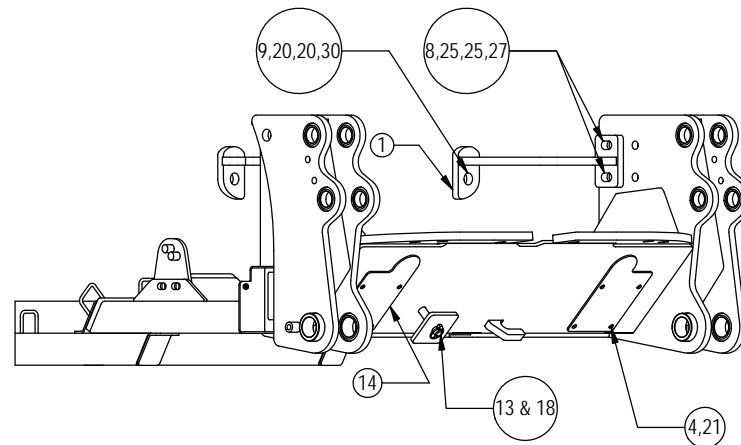

**GROUSER PRODUCTS INC.**

755 2nd Ave NW Phone 701.282.7710  
 West Fargo, ND 58078 Fax 701.282.8131  
 WWW.GROUSER.COM

TITLE: 760 - Row Trac UC Assy.

Date: 8/17/2014

DWG. NO.: 17060-A

THE INFORMATION CONTAINED IN THIS DRAWING IS THE SOLE PROPERTY OF GROUSER PRODUCTS INC ANY REPRODUCTION IN PART OR WHOLE WITHOUT THE WRITTEN PERMISSION OF GROUSER PRODUCTS INC IS PROHIBITED.

Item No.	Qty.	Part No.	Description
1A	4	16-20139	1/2" X 5-1/2" Hex Bolt Gr 5 NC
1B	4	16-20140	1/2" X 6" Hex Bolt Gr 5 NC
2	1	44-17208	760/770 CNH Rear UC Hose Routing Plate
3	4	44-17245	760/770 CNH Hose Holding Plate
4	4	53-15528	Round Tube, 760/770 Hose Routing Spacer - 3/4"
5	4	54-20744	1/2" Flat Washer
6	4	70-20604	1/2" Hex Center Lock Nut Gr 2 NC
7	2	70-20872-10	20mm Hex Nut 2.5 Pitch Class 10 Zinc

Item #A for Ag Pro Dozer  
Item #B for 12-20 Dozer Hydraulics

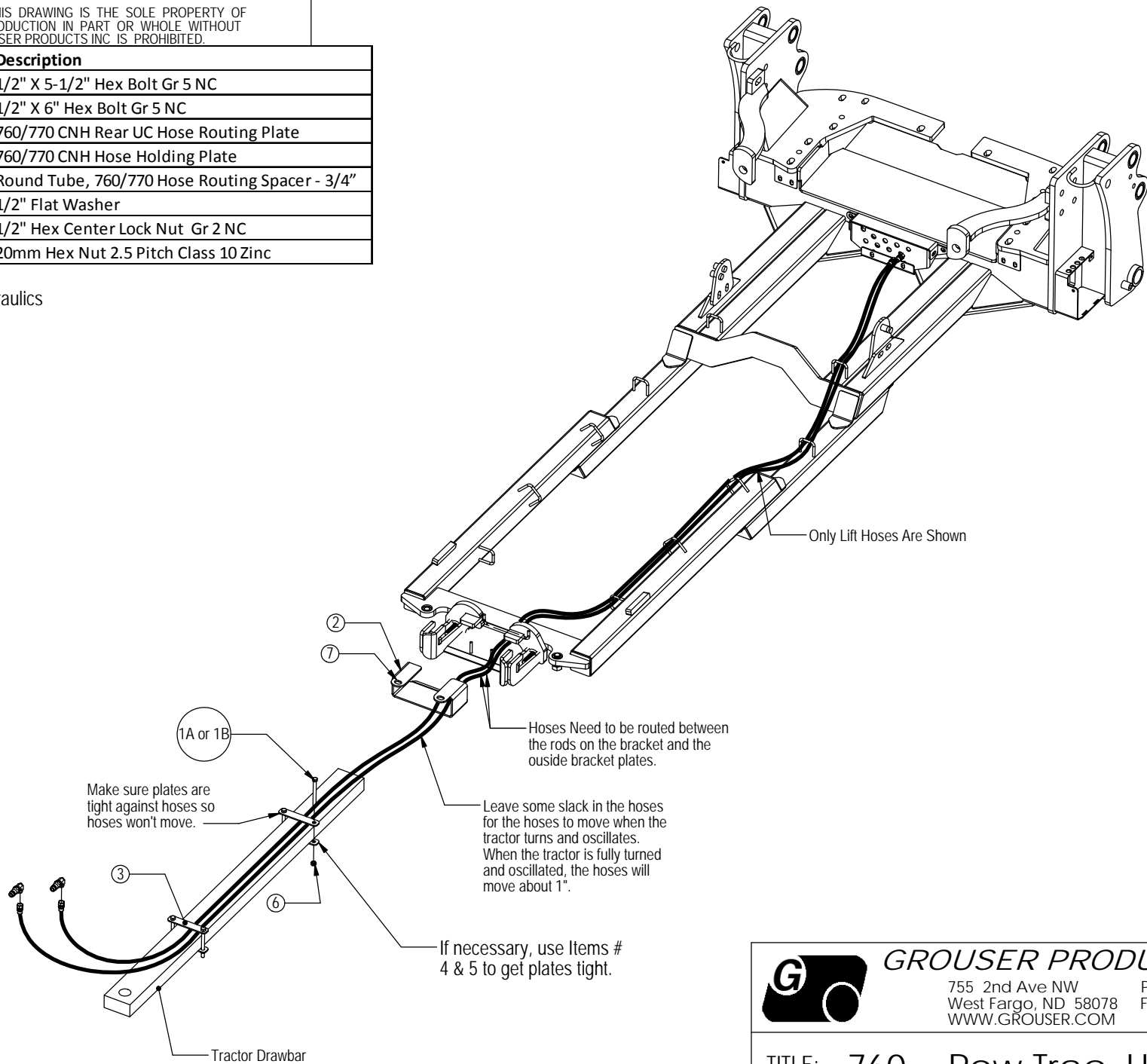

**GROUSER PRODUCTS INC.**

755 2nd Ave NW Phone 701.282.7710  
West Fargo, ND 58078 Fax 701.282.8131  
WWW.GROUSER.COM

TITLE: 760 - Row Trac UC Assy.

Date: 8/17/2014

DWG. NO.: 17060-A