



660 - CAT MT800 - NAHT Owner's Manual & Parts Book

For Models: CAT MT800

Blade Serial # 62S121948P

Matching End Ext #5

Grouser Serial # 10203250

Name Plate - Burton Island

Purchase Date
Serial Number
Model Number
Tractor Model
Dealer

Contents

Description	Page
To The Owner, Angle / Tilt Function Abbreviation Key & Unpacking Components _____	2
Maintenance & Safety Precautions _____	3
Undercarriage Installation Instructions _____	4-5
Assembling Lift Components & Initial System Startup _____	6
Lift System _____	7
Quick Attach System _____	8-9
Skid Shoe and Tilt Plate Adjustment & Torque Specifications _____	10
No Angle - Hydraulic Tilt System & Hydraulics _____	11-12
Blade Assembly _____	13
U-End Extensions _____	14
Hydraulic Schematic _____	15
Contact Us, Improvements, & Warranty _____	16

To The Owner

This manual contains information concerning the operation, adjustment, and maintenance of the 660 blade assembly. You have purchased dependable, long lasting equipment, but only by proper care and operation can you expect to receive the performance and long service built into our products. Please have all operators read this manual carefully and keep the manual available for ready reference. If you have any questions or concerns, contact Grouser Products.

Angle / Tilt Function Abbreviation Key

HAHT	Hydraulic Angle - Hydraulic Tilt	6-Way
HANT	Hydraulic Angle - No Tilt	4-Way
NAHT	No Angle - Hydraulic Tilt	4-Way
NANT	No Angle - No Tilt	2-Way

Unpacking Components

Unstrap and remove the lift frame, hoses, top arms, and any boxes of hardware from the undercarriage. If any components are missing, call Grouser.

Note

All of the parts for the end extensions are a matched set for a specific blade. All of the parts are stamped with a number mentioned on the front cover.

Maintenance

Due to the harsh environment many of our equipment operates in, the following tasks should be performed every 10 hours or less.

- Inspect all equipment before operation for existing or potential damages.
- Lubricate all joints with high quality grease.
- Inspect and tighten all bolts to torque specifications on page 10.
- Check replaceable cutting edge for wear ensuring there is enough material to prevent permanent damage to the blade.
- Make sure all non-rotating pins are secured properly.
- Check hydraulic cylinders and hoses for damage or leaks. For replacement parts, see hydraulic pages for your specific system.
- Check skid shoes for wear and replace if necessary. For adjustment, see page 10.
- Inspect all tilt-ways for aggressive wear. See page 10 for tilt plate adjustment.

Safety Precautions

A careful operator is the best operator. Most accidents can be avoided by observing certain precautions. To help prevent accidents, read and take the following precautions before operating this equipment. In addition to these precautions, please follow all safety and operational instructions of your tractor manufacturer.

The Dozer:

1. The 660 Dozer should be operated only by those who are responsible and instructed to do so.
2. Read the owner's manual carefully before using this equipment. Lack of operating knowledge can lead to accidents.
3. Keep the dozer maintained in reliable and satisfactory condition to ensure your safety.
4. Make sure the area is clear of people before moving any equipment.
5. Do not modify or permit anyone else to modify or alter the equipment and its components without first consulting Grouser Products.

Servicing the Dozer:

1. Read and follow all safety instructions provided by the tractor manufacturer.
2. Always use proper personal safety gear when performing maintenance on equipment.
3. Before servicing, relieve hydraulic pressure, stop engine and fully engage parking brake.
4. Escaping hydraulic fluid under pressure can penetrate skin causing serious injury. If fluid is injected into skin, obtain medical attention immediately.
 - DO NOT use your hand to check for leaks. Use a piece of cardboard or paper to search for leaks.
 - Stop the engine and relieve pressure before connecting or disconnecting lines.
 - Tighten all connections before starting the engine or pressurizing lines.

Storing the Dozer:

1. Thoroughly clean the dozer before storage. Use paint where necessary to prevent rust.
2. Check the dozer for worn or damaged parts. Install new parts as required.
3. Lubricate all pins and joints.

Undercarriage Installation Instructions

Caution:

- Always use precaution when working around any equipment.
- Always wear safety glasses.
- Follow tractor manufacturer's safety guidelines when installing this product.
 1. Read all instructions prior to installation.
 2. Remove weights and weight bracket from front of tractor if necessary.
 3. Remove the battery disconnect switch cover on the left side of the tractor frame.
 4. Position the undercarriage (U/C) under the tractor and center with the frame of the tractor.
 5. Lift the U/C until the holes on the tractor line up with the holes on the U/C.
 6. If there is a gap between the undercarriage and tractor frame, use shims (PN: 44-5132) to fill in the gap.
 7. At the front of the tractor, start 8 - 24mm x 100mm bolts (PN: 16-2486) with a 1" heavy washer (PN: 57-8835) on each bolt in the front 4 holes on each side. See diagrams on the next page for any clarification.
 8. Start 8 - 20mm x 100mm bolts (PN: 16-1877) with a 7/8" heavy washer (PN: 57-3681) on each bolt in the rear 4 holes on each side. See diagrams on the next page for any clarification.
 9. Start 4 - 20mm x 70mm bolts (PN: 16-1876) with a 7/8" heavy washer (PN: 57-3681) on each bolt in the bottom at the rear of the undercarriage into the tractor frame.
 10. Once all bolts are finger tight and the U/C lines up correctly with the tractor frame, torque all 20mm bolts to 300 ft-lbs. and all 24mm bolts to 450 ft-lbs.
 11. Install hose support bracket above the axle on the left side of the tractor frame. Rear will be attached with 16mm bolts (PN: 16-1620050) and 5/8" washers (PN: 57-20816). Front will be attached using washers from the front setp and 16mm bolts (PN: 16-1620050).
 12. Attach the front hose support bracket (PN: 18-5120) with 20mm x 50mm bolts (PN: 16-1878) and 3/4" flat washers (PN: 57-20747) at the front of the tractor.
 13. When routing hoses make sure they are routed through the front hose support bracket (PN: 18-5120) and are positioned to prevent premature wear.
 14. When attaching lift assembly to undercarriage, route large pin through the right side, and you will need to help lift the left side of pin into position.
 15. After first 8 hours of use, re-torque all bolts.
 16. Check all fasteners regularly to ensure proper operation of equipment.

THE INFORMATION CONTAINED IN THIS DRAWING IS THE SOLE PROPERTY OF GROUSER PRODUCTS INC. ANY REPRODUCTION IN PART OR WHOLE WITHOUT THE WRITTEN PERMISSION OF GROUSER PRODUCTS INC IS PROHIBITED.

REVISIONS:

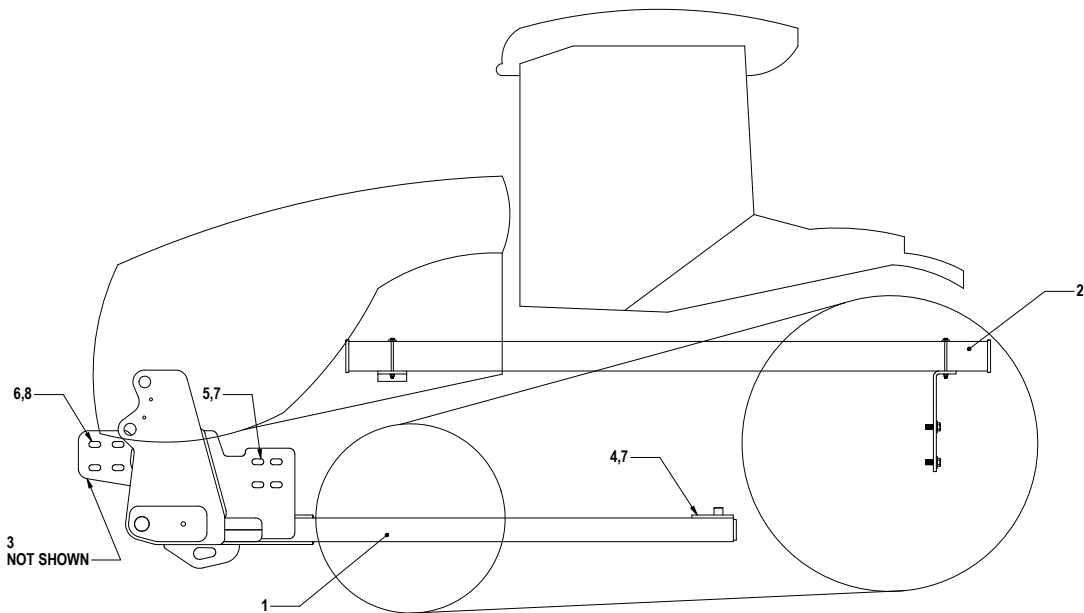

ITEM NO.	QTY.	PART NO.	DESCRIPTION
1	1	54-5100R1	Undercarriage
2	1	18-5125	Hose support bracket assy
3	1	18-5120	Front Hose Support Bracket
4	4	16-1876	20mm x 2.5mm x 70mm Gr 10.9 Metric Bolt
5	8	16-1877	20mm X 2.5mm X 100mm Hex Bolt
6	8	16-2486	24mm x 3.0mm x 100mm Gr 10.9 Metric Bolt
7	12	57-3681	7/8"ID x 2-1/4" OD x .375" Heavy Washer
8	8	57-8835	2.50 OD x 1.05 ID x .50 Thick Washer



GROUSER PRODUCTS INC.

755 2nd Ave NW Phone 701.282.7710
West Fargo, ND 58078 Fax 701.282.8131
WWW.GROUSER.COM

TITLE Mounting Instructions

DWG. NO.
54-5100
page 1

Date: 8/19/03

Scale: 1:16

Sheet: 1

THE INFORMATION CONTAINED IN THIS DRAWING IS THE SOLE PROPERTY OF GROUSER PRODUCTS INC. ANY REPRODUCTION IN PART OR WHOLE WITHOUT THE WRITTEN PERMISSION OF GROUSER PRODUCTS INC IS PROHIBITED.

REVISIONS:

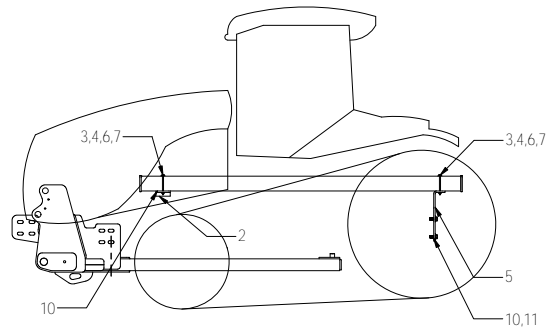
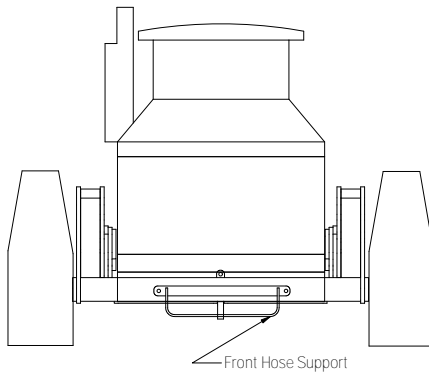

Note: Hose support bracket attached to tractor using front and rear step hardware.

Note:
Front hose support attached to tractor with 20mm x 2.5mm x 50mm (16-1878) and 3/4" washer (57-20747).

Check hoses after first hour of use. Making sure the hoses are not rubbing on edges or frame of tractor. If rubbing adjust hoses.

ITEM NO.	QTY.	PART NO.	DESCRIPTION
1	1	5127	Tube Weld
2	1	5122	Bracket
3	2	5124	Plate
4	4	16-20081	3/8 x 6-1/2 Gr.5 Hex Bolt
5	1	5123	Bracket
6	4	57-20742	3/8 Flat Washer
7	4	70-20582	3/8 Hex Nut
8	4	16-1878	20mm x 2.5mm x 50mm Gr. 10.9 Hex Bolt
9	4	57-20747	3/4" Flat Washer
10	6	16-1620050	16mm x 2.00mm x 50mm Metric Bolt
11	4	57-20816	5/8" Flat Washer Grade 8 (USS) Plated



GROUSER PRODUCTS INC.

755 2nd Ave NW Phone 701.282.7710
West Fargo, ND 58078 Fax 701.282.8131
WWW.GROUSER.COM

TITLE MOUNTING INSTRUCTIONS

DWG. NO.
54-5100
page 2

Date: 8/19/03

Scale: 1:1

Sheet: 1

Assembling Lift Components

Now that the undercarriage is installed, some assembly of components is necessary. Follow the steps listed below. Refer to Page 7 for the correct hardware and orientation of parts.

1. Remove all pins on each side of the undercarriage.
2. Position the lift frame between the two plates on both sides of the undercarriage.
3. Align the lift frame to the bottom holes of the undercarriage and attach with the proper pins and hardware.
4. Lift the end of the cylinders up and attach to the undercarriage with the proper pins and hardware.
5. Attach the top arms to the top of the undercarriage with the proper pins and hardware.
6. Remove the male quick attaches that are in the female quicks on the blade, angle frame, or tilt frame.
7. Attach the male quick attaches to the lift frame and top arms with the proper pins and hardware.
8. If the quick couplers and coupler mount are not already attached to the left top arm, attach the coupler mount to the left top arm with 4 - 3/8" flange nuts. See Page #10 for proper orientation.
9. Attach the lift hoses to the lift cylinders and to the bulkhead tee fitting at the center front of the undercarriage.
10. Take the 252" hoses and attach each one to their designated fitting at the center of the undercarriage.
11. Route the hoses thru the hose support brackets installed on the tractor back on Page 4-5.
12. Keep the hoses away from all moving parts.
13. Install each coupler into the designated hole on the coupler mount and hold them in place with the coupler retainer plate, 3/8" x 3/4" bolts and 3/8" flange nuts.
14. Take the 390" hoses and attach each one to fitting at the back of the female couplers.
15. Route the hoses thru the hose support brackets installed on the tractor back on Page 4-5.
16. Keep the hoses away from all moving parts.
17. Install the 90° fitting and the male couplers on the end of each hose and plug into the rear SCV's of the tractor.
18. Pull the pin puller handle on the left side of the quick attach system towards the outside of the blade to open the quick attach system. Refer to Page #8-9 for further clarification on the quick attach system.
19. Tilt the male quick attaches forward slightly.
20. Drive the tractor forward slowly until the top edge of the male quick attach is under the top lip of the female quick attach already on the blade assembly.
21. Tilt the male quick attaches backward till the blade is off the ground and the female quick attaches are against the front of the male quick attaches.
22. Shut off machine and set the parking brake.
23. Move the pin puller handle on the left side of the blade assembly towards the center of the blade to lock the blade in place and use the latch to lock the handle in place. If applicable, turn up the blade stands on the blade.
24. Plug the male couplers into the female couplers on the top arm.

Initial System Startup

Start the tractor and run the blade thru all the functions. If any function does not work properly, bleeding of the system may be required. If problem still persists, call Grouser Products.

Hose Routing

Note: Installer is responsible to route hoses in a practical manner. The hoses need to be routed away from sharp corners and moving parts and need to be secure.

Hoses Not Drawn to Scale

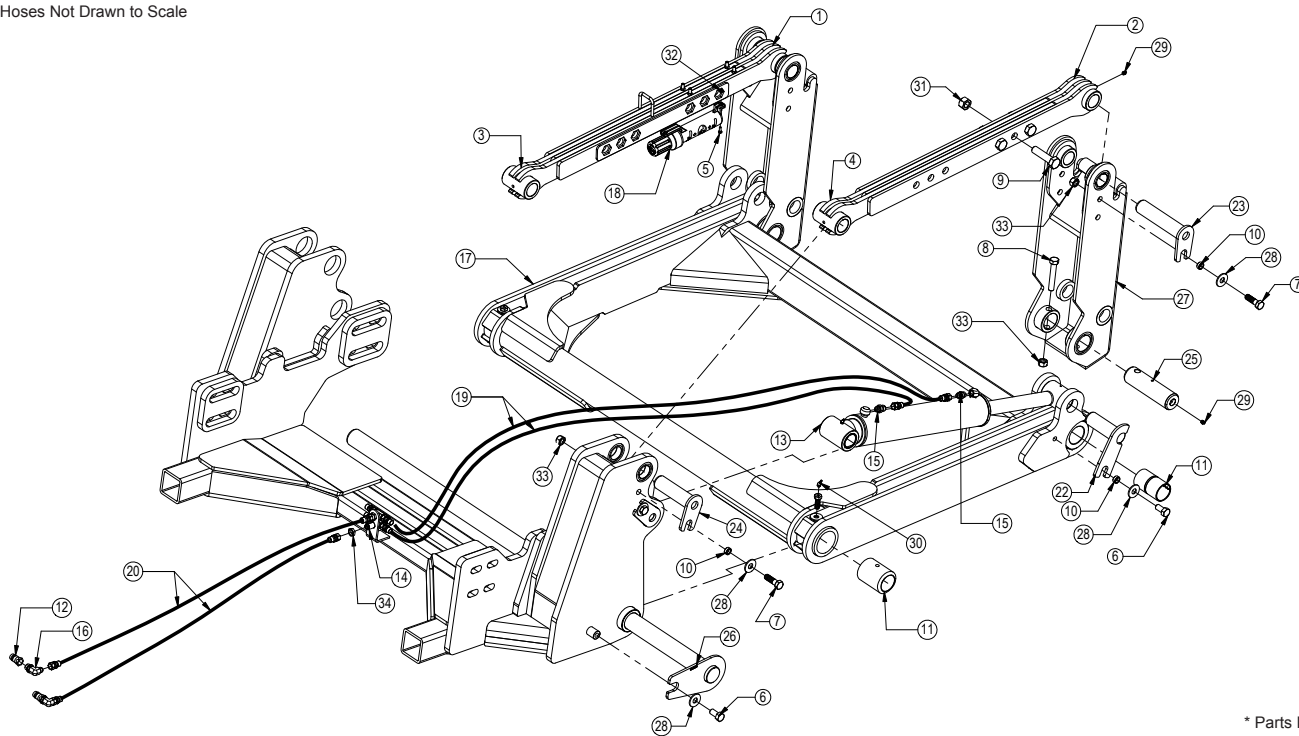

* Parts Not Shown

Item No.	Qty.	Part No.	Description
1	1	11-16330-L	Manual Pitch Top Arm, Female - Left
2	1	11-16330-R	Manual Pitch Top Arm, Female - Right
3	1	11-16335-L	Manual Pitch Top Arm, Male - Left
4	1	11-16335-R	Manual Pitch Top Arm, Male - Right
5	2	16-20002	1/4" x 3/4" Hex Bolt Gr 5 NC
6	3	16-20216	3/4" x 1-1/2" Hex Bolt Gr 5 NC
7	6	16-20220	3/4" x 2-1/2" Hex Bolt Gr 5 NC
8	2	16-20227	3/4" x 4-1/2" Hex Bolt Gr 5 NC
9	12	16-20566	1" x 4" Hex Bolt Gr 8 NC
10	8	19-13515	3/4" ID - Non Rotating Pin Spacer Bushing
11	4	19-13525	2.75 x 2.50 x 4.75 Spring Bushing
12	2	25-34342	Tappet Quick Coupler - Male
13	2	26-17747	5x20 Long Cylinder - Bushed Tube Ends -Cold Weather
14	2	31-34021	Bulkhead Branch Tee JIC (2703-10-10-10)
15	4	31-34042	Straight JIC x O-Ring (6400-10-10)
16	2	31-34052	Straight Thread Elbow 90° JIC x O-Ring (6801-10-10)
17	1	32-17830	660 Arctic Pro Lift Frame (Single Pin)
18	1	34-14961	Manual Canister
19	4	35-12213-0870	87" x 5/8" -10JIC-810JIC Cold Temp Hose
20	2	35-12213-2520	252" x 5/8" -10JIC-810JIC Cold Temp Hose
21*	1	43-12929-L	Pin Weld - Long Ear (Lift Cyl. / Lift Frame) - Left
22	1	43-12929-R	Pin Weld - Long Ear (Lift Cyl. / Lift Frame) - Right
23	2	43-13478	Pin Weld (Top Arm / QA)
24	4	43-13482	Pin Weld (Top Arm / UC & Lift Cyl. / UC)
25	2	43-14720	Pin (Lift Frame / QA)
26	1	43-17806	Cat MT800 HD Pin Weld (Lift Frame / UC)
27	2	45-12175	700 Series Male Quick Attach
28	9	57-20747	3/4" Flat Washer
29	6	58-9369	Grease Zerk 1/8" NPT Straight
30	2	58-9371	Grease Zerk 1/8" NPT 45°
31	12	70-20599	1" Hex Nut Gr 8 NC
32	2	70-20610	1/4" Nyloc Hex Nut Gr 5 NC
33	8	70-20607	3/4" Hex Center Lock Nut Gr 2 NC
34	2	70-20808	7/8" Hex Jam Nut

NOTE: When ordering cylinder seal kits, the part number on the cylinder is needed. The number is stamped on the base end of the cylinder opposite of the hydraulic ports.

No. On Cylinder	Part No.	Description
26-17747	49-11141	CTD Seal Kit 5x2" (SKC50-115S) Cold Weather For 5x20 Nitride Cylinder

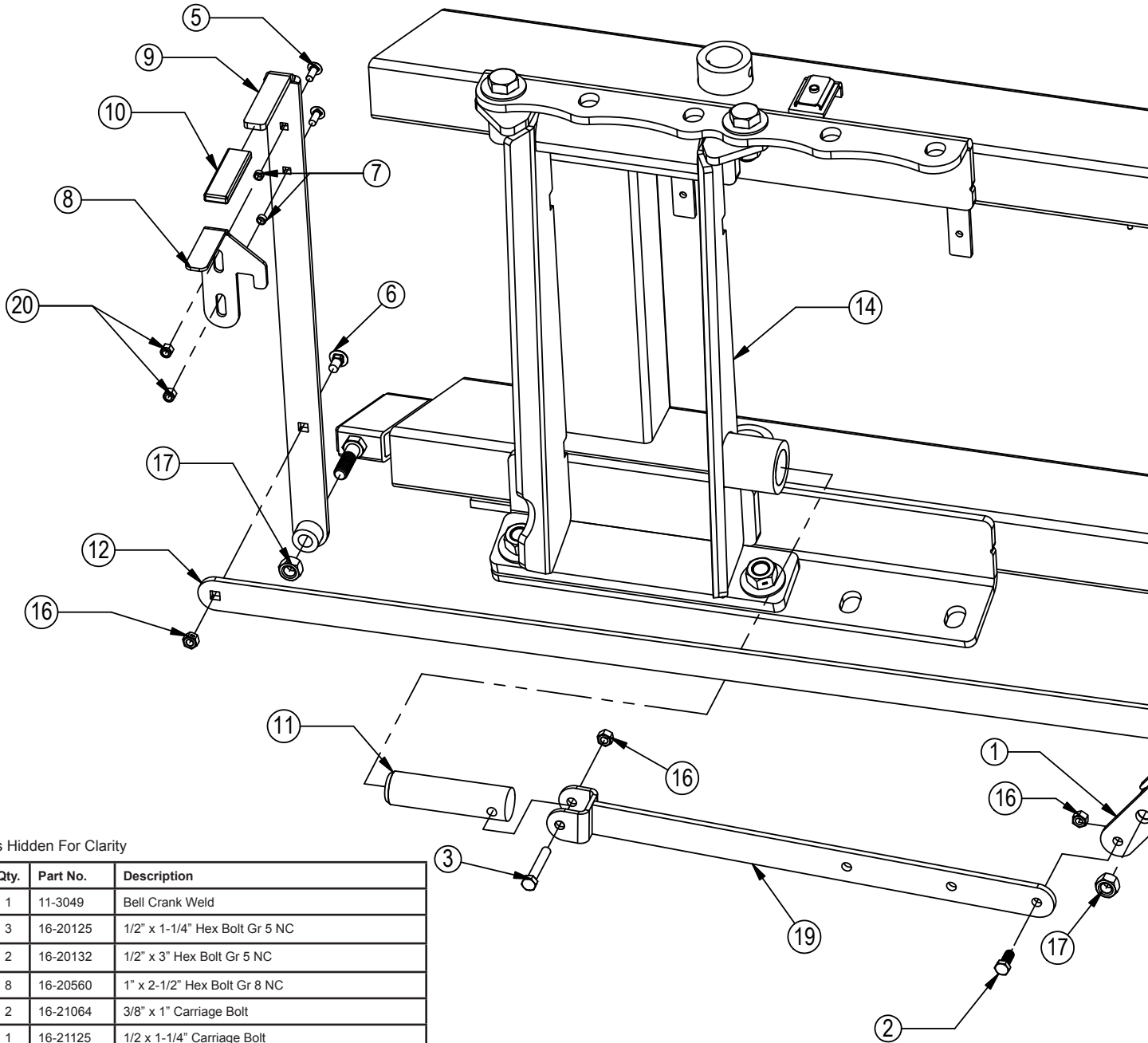

Some Parts Hidden For Clarity

Item No.	Qty.	Part No.	Description
1	1	11-3049	Bell Crank Weld
2	3	16-20125	1/2" x 1-1/4" Hex Bolt Gr 5 NC
3	2	16-20132	1/2" x 3" Hex Bolt Gr 5 NC
4	8	16-20560	1" x 2-1/2" Hex Bolt Gr 8 NC
5	2	16-21064	3/8" x 1" Carriage Bolt
6	1	16-21125	1/2 x 1-1/4" Carriage Bolt
7	2	19-13577	NR Pin Spacer Clevis End
8	1	39-14663	AG Pro Pin Puller Latch
9	1	39-14665	AG Pro Pin Puller Handle Weld
10	1	39-3072	Handle Cover (Orange)
11	2	43-3050	QA Lock Pin
12	1	44-14662	AG Pro Pin Puller Link Plate
13	1	45-16035-R	HD Female Vertical Bolt On Quick Attach, Right
14	1	45-16035-L	HD Female Vertical Bolt On Quick Attach, Left
15	16	57-20819	1" Flat Washer Heavy Duty Gr 8 (USS)
16	6	70-20604	1/2" Hex Center Lock Nut Gr 2 NC
17	2	70-20607	3/4" Hex Center Lock Nut Gr 2 NC
18	8	70-20609	1" Hex Center Lock Nut Gr 2 NC
19	2	75-14655	AG Pro Pin Puller Link Weld
20	2	70-20622	3/8" Flange Nut

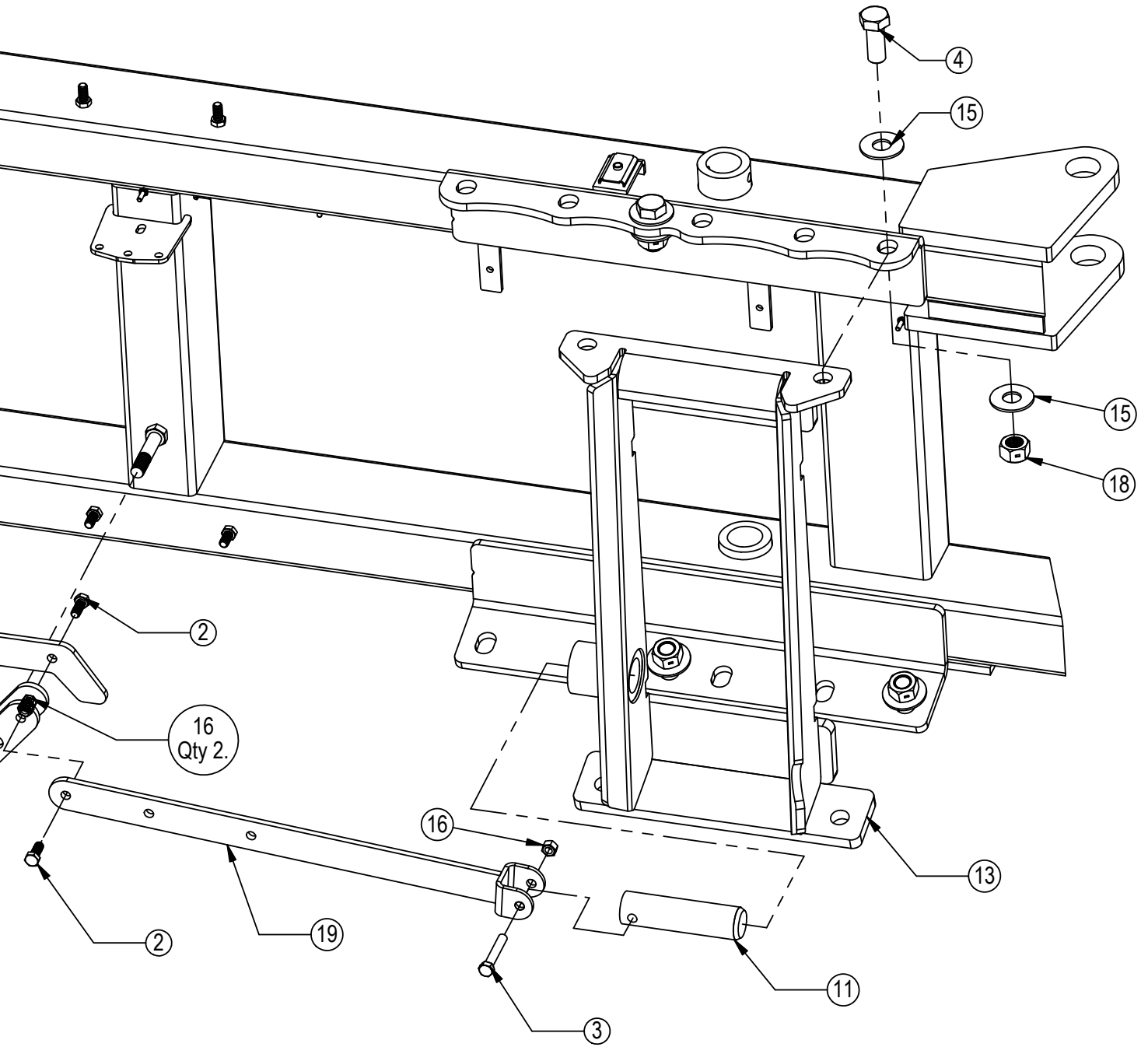

Skid Shoe and Tilt Plate Adjustment

Skid Shoe Adjustment:

1. Raise and secure blade to access skid shoe bolts and nuts.
2. Loosen nuts and set skid shoe depth by sliding the shoe back and forth in direction 'A' shown in Figure 1.
3. Once the depth is set, tighten bolts to 150 ft-lbs.
4. When skid shoes are worn down, replace with new skid shoes.

Tilt Plate Adjustment:

1. Remove bolts and tilt plates.

Note: Don't remove all of the bolts at the same time.

2. Add or remove washers as needed to adjust tilt-way clearance to have 1/16" - 1/8" of clearance in direction 'B' shown in Figure 1.
3. Once the tilt-way clearance is set, tighten bolts to 640 ft-lbs.

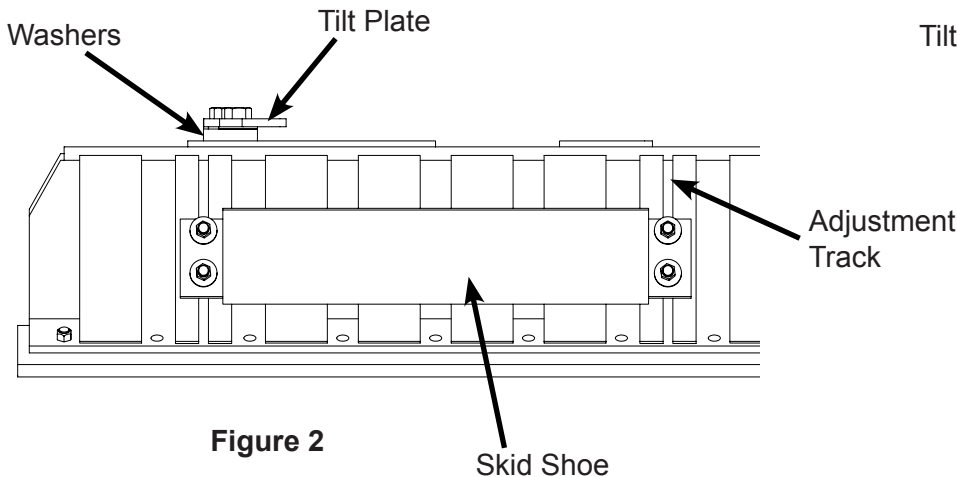

Figure 2

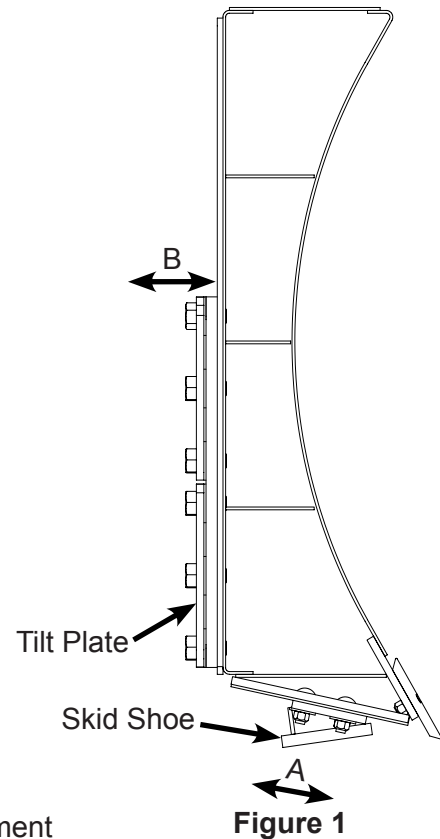

Figure 1

Torque Specifications

All bolts should be tightened to the specifications that are stated. If specifications are not stated, follow torque charts below.

Size	Torque - Dry (ft-lbs)			
	SAE Grade 5		SAE Grade 8	
	UNC	UNF	UNC	UNF
5/16	17	19	24	27
3/8	30	35	45	50
7/16	50	55	70	80
1/2	75	85	110	120
9/16	110	120	150	170
5/8	150	170	210	240
3/4	260	300	380	420
7/8	430	470	600	670
1	640	720	910	1020

Size	Torque - Dry (ft-lbs)
	Grade 10.9
M18 x 2.50	284
M20 x 2.50	401
M22 x 2.50	547
M24 x 3.00	694

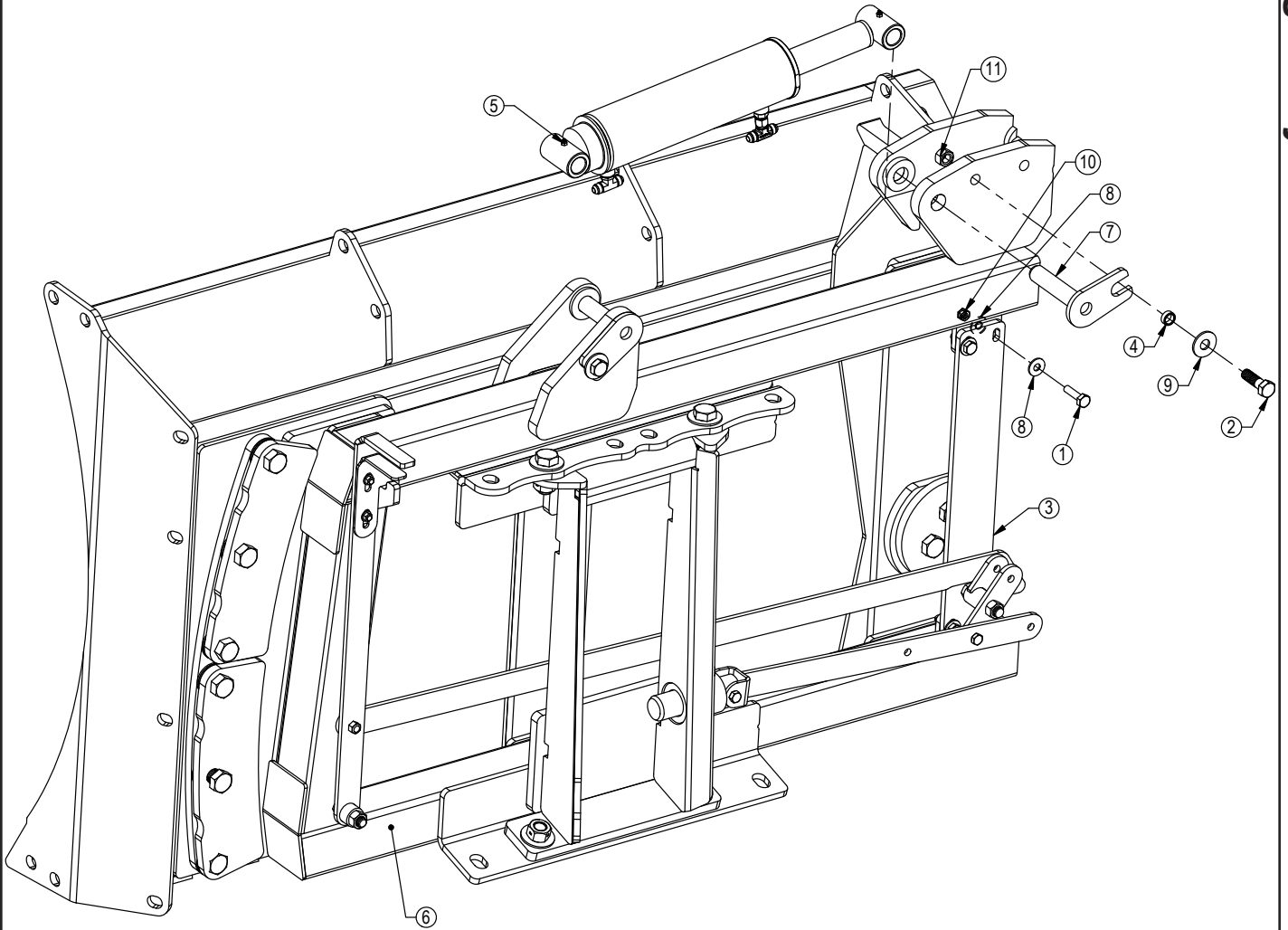

Item No.	Qty.	Part No.	Description
1	4	16-20128	1/2" x 2" Hex Bolt Gr 5 NC
2	4	16-20220	3/4" x 2-1/2" Hex Bolt Gr 5 NC
3	1	18-14658	NAXT Center Bracket
4	4	19-13515	3/4" ID - Non Rotating Pin Bushing
5	2	26-34728	4 x 12 Cylinder w/ Tube Ends
6	1	32-17810	660 Arctic Pro - NAHT Tilt Frame
7	4	43-16116	1-1/4" Pin Weld (HD Tilt)
8	8	57-20744	1/2" Flat Washer
9	4	57-20747	3/4" Flat Washer
10	4	70-20604	1/2" Hex Center Lock Nut Gr 2 NC
11	4	70-20607	3/4" Hex Center Lock Nut Gr 2 NC

Hoses Not Drawn To Scale

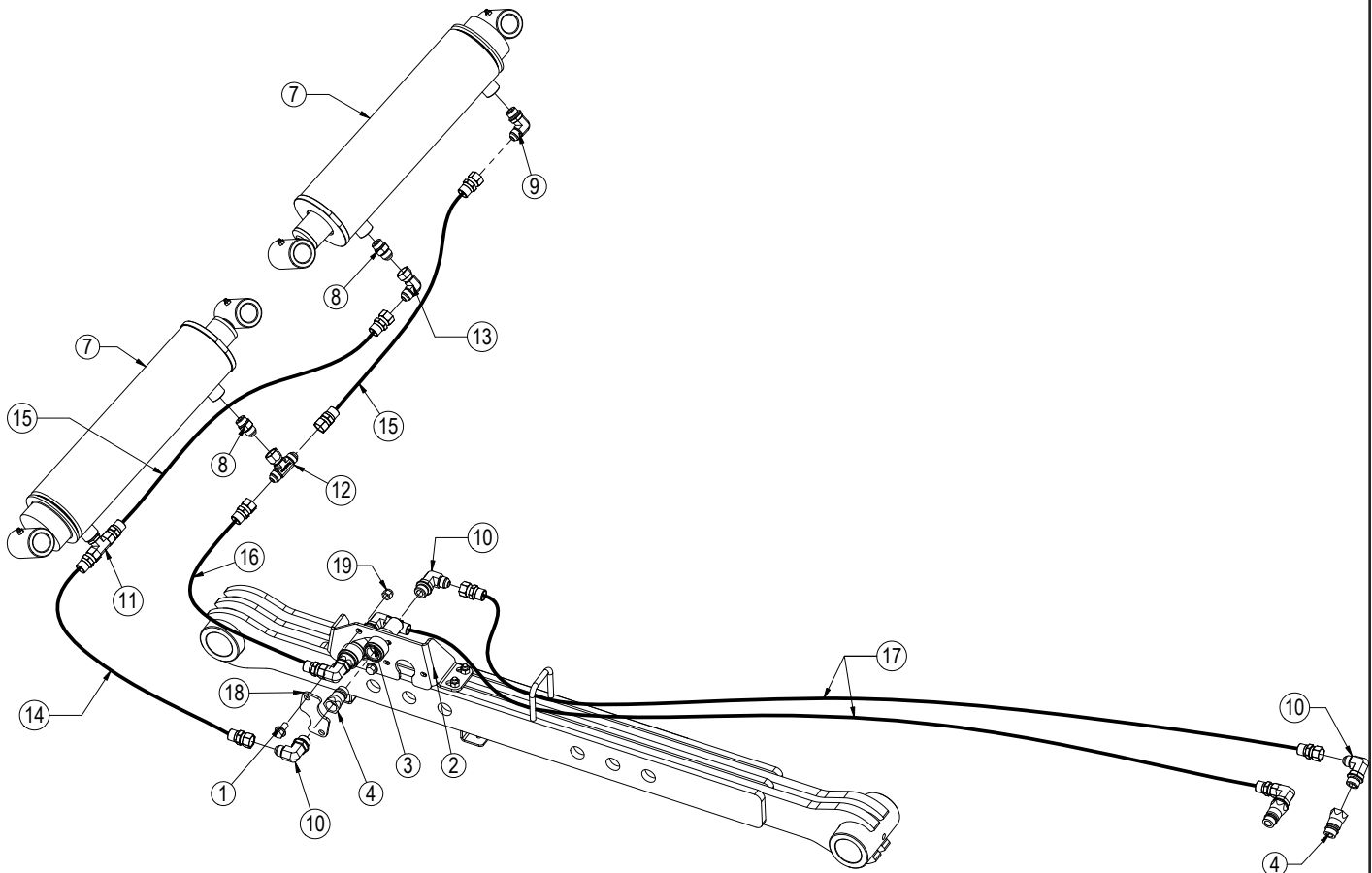

* Parts Not Shown

NOTE: When ordering cylinder seal kits, the part number on the cylinder is needed. The number is stamped on the base end of the cylinder opposite of the hydraulic ports.

Item No.	Qty.	Part No.	Description
1	2	16-35C612	3/8" x 3/4" Flanged Bolt
2	1	18-14733	Female Coupler Mount - NAHT
3	2	25-34321	Tappet Quick Coupler Female
4	4	25-34342	Tappet Quick Coupler Male
5*	4	25-3453	Pioneer Dust Cap Tilt (Green)
6*	2	25-3454	Pioneer Dust Plug Tilt (Green)
7	2	26-34728	4 x 12 Cylinder W/ Tube Ends
8	2	31-34040	Straight JIC x O-Ring (6400-08-08)
9	1	31-34050	Straight Thread Elbow 90° JIC x O-Ring (6801-8-8)
10	6	31-34051	Straight Thread Elbow 90° JIC x O-Ring (6801-8-10)
11	1	31-34060	Branch Tee JIC x O-Ring (6803-8-8-8)
12	1	31-34080	Swivel Nut Branch Tee JIC (6600-8-8-8)
13	1	31-34100	Swivel Nut Elbow 90° JIC (6500-8-8)
14	1	35-12216-0400	40" x 1/2" -8 FJIC x -8 FJIC Cold Temp (GH 120)
15	2	35-12216-0450	45" x 1/2" -8 FJIC x -8 FJIC Cold Temp (GH 120)
16	1	35-12216-0500	50" x 1/2" -8 FJIC x -8 FJIC Cold Temp (GH 120)
17	2	35-12216-3900	390" x 1/2" -8 FJIC x -8 FJIC Cold Temp (GH 120)
18	1	44-14734	Female Coupler Retainer - NAHT
19	6	70-20622	3/8" Flange Hex Nut

No. On Cylinder	Part No.	Description
26-34728	49-12272	Seal Kit 4" Bore x 2" Rod (647204) Nitrided Rod

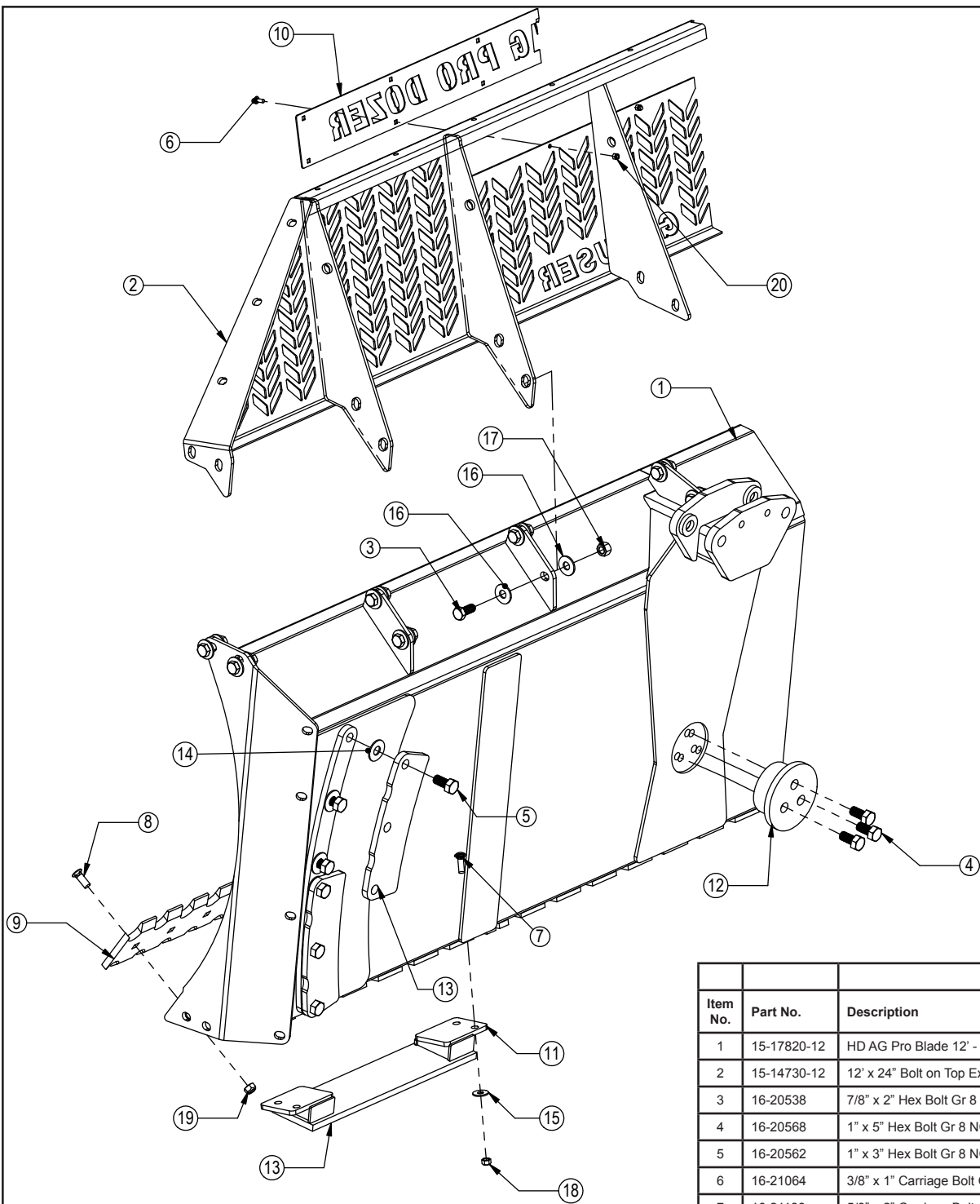

Item No.	Part No.	Description	Blade Length	Qty.
			12'	
1	15-17820-12	HD AG Pro Blade 12' - Slant Top		1
2	15-14730-12	12' x 24" Bolt on Top Extension - Slant Top		1
3	16-20538	7/8" x 2" Hex Bolt Gr 8 NC		14
4	16-20568	1" x 5" Hex Bolt Gr 8 NC		3
5	16-20562	1" x 3" Hex Bolt Gr 8 NC		12
6	16-21064	3/8" x 1" Carriage Bolt Gr 5 NC		8
7	16-21188	5/8" x 2" Carriage Bolt Gr 5 NC		8
8	16-21748	3/4" x 2" Plow Bolt Gr 8 NC		24
9	29-11223-6	6'- 3/4" x 8" Serrated Cutting Edge		2
10	44-14830	Custom Name Plate		1
11	50-16710	HD Skid Shoe 33"		2
12	50-12380	HD Center Tilt Way Cover		1
13	52-16222	HD Tilt Plate		4
14	57-20749	1" Flat Washer		12
15	57-20816	5/8" Flat Washer Grade 8 (USS)		8
16	57-20818	7/8" Flat Washer Heavy Duty Grade 8 (USS)		28
17	70-20598	7/8" Hex Nut Gr 8 NC		14
18	70-20646	5/8" Hex Top Lock Nut Gr 5 NC		8
19	70-20647	3/4" Hex Top Lock Nut Gr 5 NC		24
20	70-20622	3/8" Flange Nut		8

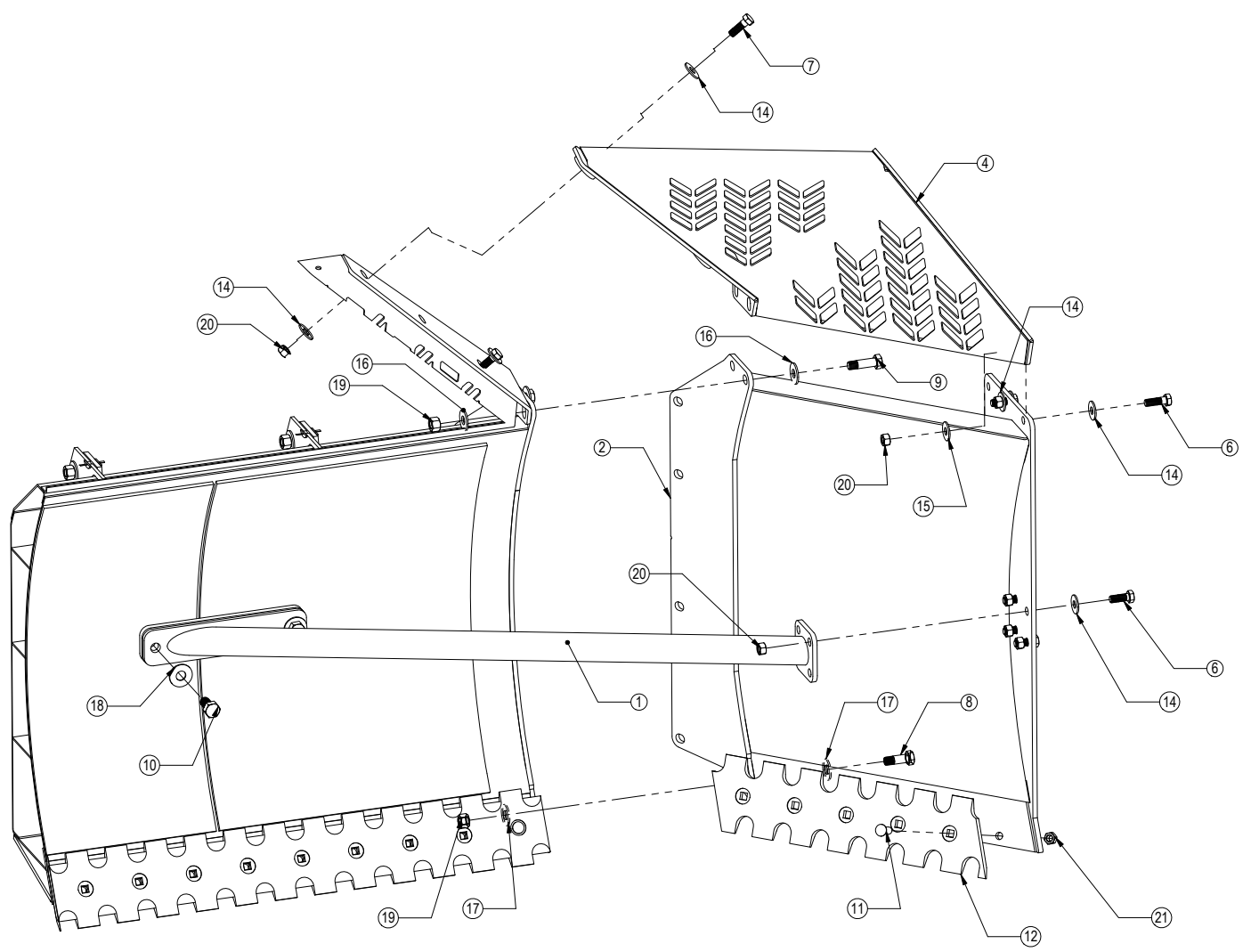

Only Left Side Shown

* Parts Not Shown

Item No.	Qty.	Part No.	Description
1	2	11-3699	U-End Extension Reinforcement Arm
2	1	15-15810-L	Slant Top U-End Extension - Left
3*	1	15-15810-R	Slant Top U-End Extension - Right
4	1	15-15815-L	Slant Top U-End Extension - Top Ext. - Left
5*	1	15-15815-R	Slant Top U-End Extension - Top Ext. - Right
6	12	16-20218	3/4" x 2" Hex Bolt Gr 8 NC
7	4	16-20219	3/4" x 2-1/4" Hex Bolt Gr 8 NC
8	12	16-20540	7/8" x 2-1/2" Hex Bolt Gr 8 NC
9	4	16-20542	7/8" x 3" Hex Bolt Gr 8 NC
10	4	16-20558	1" x 2" Hex Bolt Gr 8 NC
11	10	16-21748	3/4" x 2" Plow Bolt Gr 8 NC
12	1	29-16603-L	Serrated Cutting Edge 8" Left Cut
13*	1	29-16603-R	Serrated Cutting Edge 8" Right Cut
14	22	57-20747	3/4" Flat Washer
15	2	57-20757	3/4" SAE Hardened Flat Washer - 1-1/2" OD
16	8	57-20758	7/8" SAE Hardened Flat Washer - 1-3/4" OD
17	12	57-20818	7/8" Flat Washer Heavy Duty Grade 8 (USS)
18	4	57-20819	1" Flat Washer Heavy Duty Grade 8 (USS)
19	16	70-20598	7/8" Hex Nut Gr 8 NC
20	16	70-20607	3/4" Hex Center Lock Nut NC
21	10	70-20647	3/4" Hex Top Lock Nut Gr 5 NC

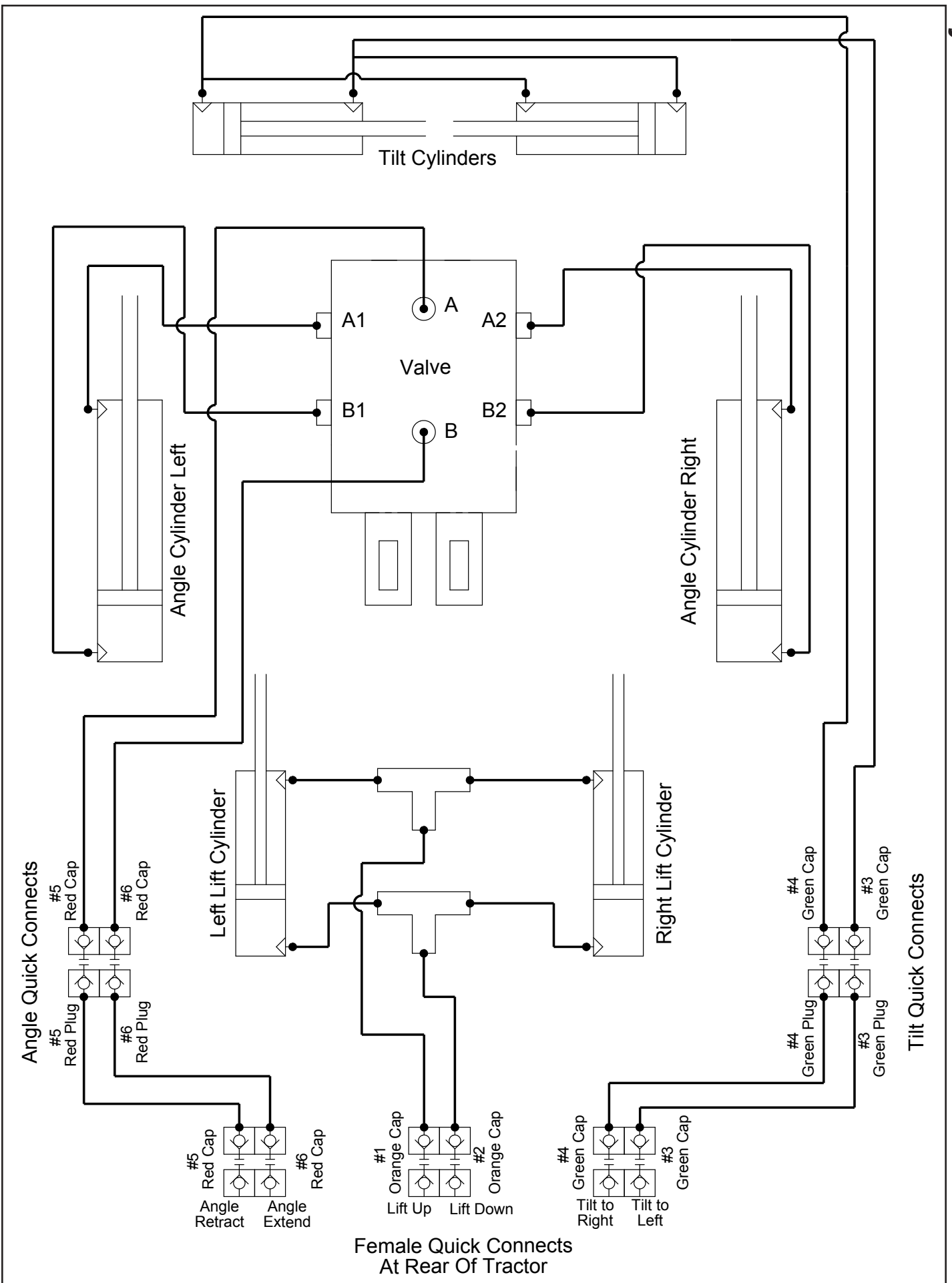

Contact Us

As always, if you have any questions about your 660 Dozer or other products made by Grouser, feel free to contact us.

Grouser Products

755 2nd Ave NW - West Fargo, ND 58078

Phone: 1-800-747-6182

Fax: 1-701-282-8131

E-mail: grouser@grouser.com

Website: www.grouser.com



Improvements

Grouser Products Inc. is continually striving to improve its products. We reserve the right to change prices, specification, or equipment at any time without notice. We also reserve the right to make improvements or changes when it becomes practical and possible to do so without incurring any obligation to make changes or additions to the equipment sold previously.

Warranty

Grouser Products warrants to the original purchaser of each item that the product be free from defects in material and workmanship under normal use and service for a period of one year. If such equipment is found to be defective within one year, it is the obligation of Grouser Products under this warranty to repair or replace (exclusive of the cost of labor and transportation), any equipment or parts, in the judgment of Grouser Products to be defective in material or workmanship.

All equipment or parts claimed to be defective in material or workmanship must be made available for inspection at the place of business of a dealer authorized to handle the equipment covered by this warranty, or, upon request by Grouser Products, shipped to the Grouser Products factory in West Fargo, North Dakota. Grouser Products shall have no obligation to bear the cost of labor or transportation in connection with replacement or repair of any such defective parts in the setup process.

This warranty covers only defects in material and workmanship. It does not cover depreciation or damage caused by normal wear, accident, improper assembly, improper adjustments, improper maintenance including lack of proper lubrication, or improper use. Therefore, Grouser Products liability under this warranty shall not be effective or actionable unless the equipment is assembled, maintained and operated in accordance with the operating instructions accompanying the equipment. Grouser Products shall have no liability if the equipment has been altered or reworked without the written authorization of Grouser Products.

Grouser Products' parts, which are furnished under this warranty and properly installed, shall be warranted to the same extent as the original parts under this warranty if, and only if, such parts are found to be defective within the original warranty period covering the original equipment.

