



# **12-20 (V6) - AG PRO PLUS**

## **Owner's Manual**

### **&**

## **Parts Book**

Purchase Date
Serial Number
Model Number
Tractor Model
Dealer

# Contents

---

---

Description	Page
Safety Precautions, Torque Specifications, and Warning _____	3
Unpacking Components, Undercarriage Installation & Assembling Lift Components _____	4
Installing Hydraulic Coupler Components _____	4
Lift System _____	5
Tractor Side Hydraulic Hose Routing (Left Side) _____	6
Tractor Side Hydraulic Hose Routing (Right Side) _____	7
Initial Startup Instructions _____	8
Connecting & Disconnecting the Blade, Skid Shoe and Tilt Plate Adjustment _____	9
Blade Assembly _____	10-11
Hydraulic Instructions, Angle System & 2-Lever Angle System Operating Instructions _____	11
Relief Valve Instructions _____	12-13
NANT Blade & End Plate Assembly _____	14
No Angle - Hydraulic Tilt System & Hydraulics _____	16
Angle Hydraulic Components _____	16
Quick Attach System _____	17-18
Hydraulic Angle - Hydraulic Tilt & Hydraulic Angle - No Tilt System _____	18-19
Hydraulic Angle - Hydraulic Tilt & Hydraulic Angle - No Tilt Hose Routing (Blade Side) _____	20-21
Hydraulic Angle - 2 Lever System Hose Routing (Blade Side) _____	22-23
12-20 NAHT & HAHT Blade Hydraulic Hose Routing _____	24
Blade Hydraulic Schematic & Wire Harness _____	25
Hydraulic Schematic _____	26
2- Lever Hydraulic Schematic _____	27
Contact Us, Improvements, & Warranty _____	28

---

---

## To The Owner

This manual contains information concerning the operation, adjustment, and maintenance of the 12-20 blade assembly. You have purchased dependable, long lasting equipment, but only by proper care and operation can you expect to receive the performance and long service built into our products. Please have all operators read this manual carefully and keep the manual available for ready reference. If you have any questions or concerns, contact Grouser Products.

---

---

## Maintenance

**Due to the harsh environment many of our equipment operates in, the following tasks should be performed every 10 hours or less.**

- Inspect all equipment before operation for existing or potential damages.
- Lubricate all joints with high quality grease.
- Inspect and tighten all bolts to torque specifications on page 3.
- Check replaceable cutting edge for wear ensuring there is enough material to prevent permanent damage to the blade.
- Make sure all non-rotating pins are secured properly.
- Check hydraulic cylinders and hoses for damage or leaks. For replacement parts, see hydraulic pages for your specific system.
- Check skid shoes for wear and replace if necessary. For adjustment, see page 9.
- Inspect all tilt-ways for aggressive wear. See page 9 for tilt plate adjustment.

# Safety Precautions

A careful operator is the best operator. Most accidents can be avoided by observing certain precautions. To help prevent accidents, read and take the following precautions before operating this equipment. In addition to these precautions, please follow all safety and operational instructions of your tractor manufacturer.

## The Dozer:

1. The 12-20 Dozer should be operated only by those who are responsible and instructed to do so.
2. Read the owner's manual carefully before using this equipment. Lack of operating knowledge can lead to accidents.
3. Keep the dozer maintained in reliable and satisfactory condition to ensure your safety.
4. Make sure the area is clear of people before moving any equipment.
5. Do not modify or permit anyone else to modify or alter the equipment and its components without first consulting Grouser Products.

## Servicing the Dozer:

1. Read and follow all safety instructions provided by the tractor manufacturer.
2. Always use proper personal safety gear when performing maintenance on equipment.
3. Before servicing, relieve hydraulic pressure, stop engine and fully engage parking brake.
4. Escaping hydraulic fluid under pressure can penetrate skin causing serious injury. If fluid is injected into skin, obtain medical attention immediately.
  - DO NOT use your hand to check for leaks. Use a piece of cardboard or paper to search for leaks.
  - Stop the engine and relieve pressure before connecting or disconnecting lines.
  - Tighten all connections before starting the engine or pressurizing lines.

## Storing the Dozer:

1. Thoroughly clean the inside and outside of the dozer before storage. Use paint where necessary to prevent rust.
2. Check the dozer for worn or damaged parts. Install new parts as required.
3. Lubricate all pins and joints.

# Torque Specifications

All bolts should be tightened to the specifications that are stated. If specifications are not stated, follow torque charts below.

Size	Torque - Dry (ft-lbs)			
	SAE Grade 5		SAE Grade 8	
	UNC	UNF	UNC	UNF
5/16	17	19	24	27
3/8	30	35	45	50
7/16	50	55	70	80
1/2	75	85	110	120
9/16	110	120	150	170
5/8	150	170	210	240
3/4	260	300	380	420
7/8	430	470	600	670
1	640	720	910	1020

	Torque - Dry (ft-lbs)
Size	Grade 10.9
M18 x 2.50	284
M20 x 2.50	401
M22 x 2.50	547
M24 x 3.00	694

## Warning

When using the dozer blade, pay special attention to the area between the blade and the hood of the tractor. In the right conditions, material can build up. Grouser Products is not responsible for careless operation of the blade.

---

---

# Unpacking Components

---

---

Unstrap and remove the lift frame, hoses, top arms, and any boxes of hardware from the undercarriage. If any components are missing, call Grouser.

---

---

## Undercarriage Installation

---

---

Install undercarriage per the tractor specific mounting instructions.

---

---

## Assembling Lift Components

---

---

Some assembly of Lift system components is necessary. Follow the steps listed below. Refer to Page 5 for the correct hardware and orientation of parts.

1. Remove all pins and fasteners on each side of the undercarriage and set aside for later installation.
2. Position the lift frame between the two plates on both sides of the undercarriage and align to the bottom holes.
3. Attach the lift frame, the base end of the lift cylinders, and the top arms to the undercarriage. Refer to Page 5 for proper components and orientation.
4. Attach the male quick attaches to the lift frame, and to the top arms. See Page 5 for proper orientation.
5. Tighten all fasteners.
6. Connect the lift hoses to the lift cylinders. The hoses are marked with 2 Orange Bands for the base end and 1 Orange Band for the rod end.
7. Verify that hoses are not twisted and protected from rubbing on any sharp edges. See picture below for proper hose routing.

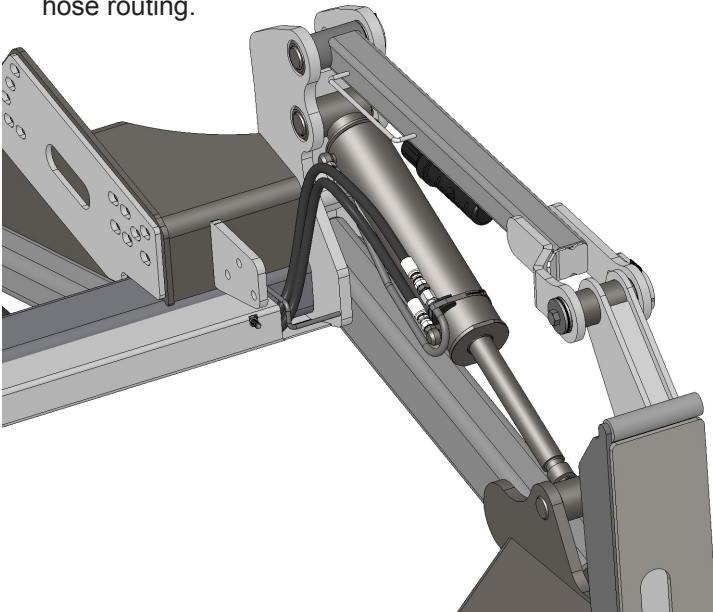

---

---

## Installing Hydraulic Coupler Components

---

---

**Note: Refer to Diagram on Page 6 for further information on hose routing and hose positions. The quantity and location of the female couplers is determined by blade functionality.**

8. Attach the coupler mounts to the left top arm and install the female quick couplers and 90° fittings.
9. Install each coupler into the designated hole on the coupler mount and fasten them in place with the coupler retainer plate, 3/8" x 3/4" bolts and 3/8" flange nuts.
10. Identify each remaining hose at the front of the undercarriage by the colored bands on the end of the hose and connect the hose to the corresponding 90° fitting and female coupler in the coupler mount.
11. If applicable, attach the wire harness to the coupler mount. Hold in place with a zip tie. Run the other end of the wire harness up into the cab of the tractor.
12. Locate the keyed and fused power supply. Connect the red wire to the power and the black to the ground. Install provided switch into an open switch hole in the right overhead console or another convenient place in the tractor.
13. Connect the wire harness to the switch.
14. Continue on Page 7 for instructions on how to remove the air from the system.

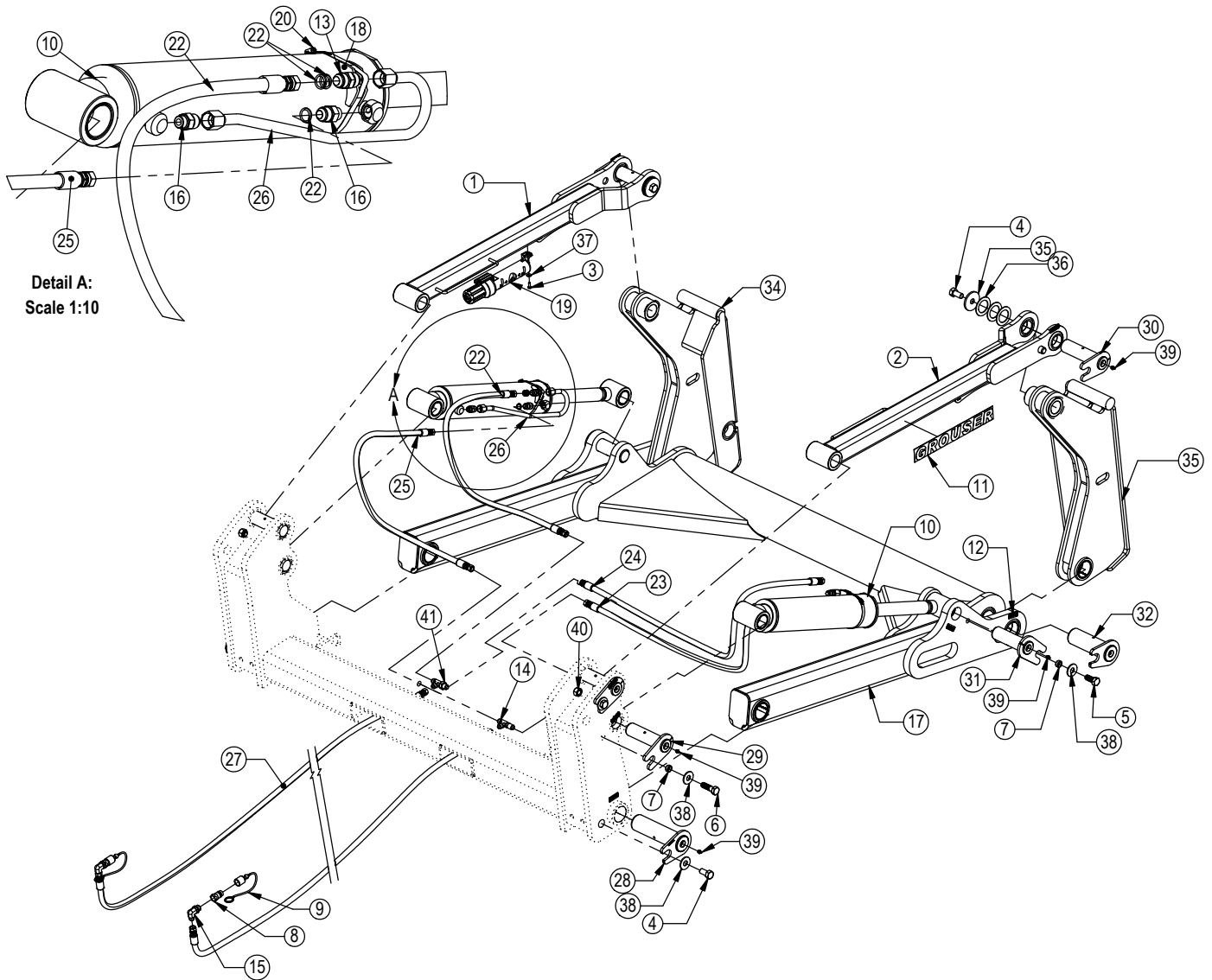

**Detail A:**  
Scale 1:10

\* Parts Not Shown

Item #A for Claas Tractors (24-19606)

Item #B for Steiger (24-19601), New Holland (24-19601), and JD 9R Tractors (24-19602, 24-19603 or 24-19609)

Item #C for JD 9RX (24-19608), Versatile (24-19604) and Challenger Tractors (24-19607)

NO.	QTY.	PART NO.	DESCRIPTION
1	1	11-18165-L R3	Top Arm, Ag Pro +
2	1	11-18165-R R3	Top Arm, Ag Pro +
3	2	16-20002	1/4" x 3/4" Hex Bolt Gr 5 NC
4	4	16-20216	3/4" x 1-1/2" Hex Bolt Gr 5 NC
5	4	16-20217	3/4" x 1-3/4" Hex Bolt Gr 5 NC
6	4	16-20220	3/4" x 2-1/2" Hex Bolt Gr 5 NC
7	8	19-13515	Spacer, NR Pin
8	2	25-34342	Tappet Quick Coupler Male - Poppet Style
9	2	25-3457	Pioneer Dust Cap Lift (Orange)
10	2	26-34745	4.5 x 18 Hydraulic Cylinder
11	2	27-9504	Decal, Grouser Horizontal
12	12	27-9507	Decal, Grease
13	2	31-11699-10-10	JIC Union
14	2	31-34194	Union Tee JIC
15B,C	2	31-34059	Straight Thread Elbow 90° JIC x O-Ring
15A	2	31-6802-12-10	Straight Thread Elbow 45° JIC x O-Ring
16	4	31-6400-10-8	Straight JIC x O-Ring
17	1	32-18630	Lift Frame, Ag Pro Plus
18	2	34-12932	Cylinder Saddle
19	1	34-14961	Manual Canister Small
20	2	34-16578	Hose Clamp (worm drive - 4.5)
22	15	34-18889-OR	-12 Orange - Spiral Band

NO.	QTY.	PART NO.	DESCRIPTION
22	1	35-12636-0515	51.5" x 5/8" -10JIC/-10JIC Hose
23	1	35-12636-0535	53.5" x 5/8" -10JIC/-10JIC Hose
24	1	35-12636-0665	66.5" x 5/8" -10JIC/-10JIC Hose
25	1	35-12636-0670	67" x 5/8" -10JIC/-10JIC Hose
26	2	35-18240	Lift Cylinder Steel Line
27A,B	2	35-12329-2930	293" (24.42") x 3/4" -12JIC/-12JIC Hose
27C	2	35-18984-3200	320" (26.67") x 3/4" -12JIC/-12JIC Hose
28	2	43-14725	Lift Frame / UC Pin
29	4	43-18120	Top Pin Weld
30	2	43-18127	Top Arm Pin Weld
31	2	43-18175	Lift Cyl Pin Weld
32	2	43-18635	Ag Pro Plus QA Pin
34	1	45-18130-L R5	Ag Pro + Male QA
35	1	45-18130-R R5	Ag Pro + Male QA
35	2	57-1530	3" OD X .75 ID X .25" HD Flat Washer
36	6	57-1811	2" Washer
37	2	57-20740	1/4" Flat Washer
38	10	57-20747	3/4" Flat Washer
39	12	58-9369	Straight 1/8" NPT Grease Zerk
40	2	70-20607	3/4" Hex Center Lock Nut NC
41	1	70-20807	3/4" Hex Jam Nut NF
		<b>Cylinder</b>	<b>Part No. Description</b>
		26-34745	49-12278 Seal Kit 4.5" Bore x 2" Rod (658366) Nitrided Rod

Hoses Not Drawn To Scale

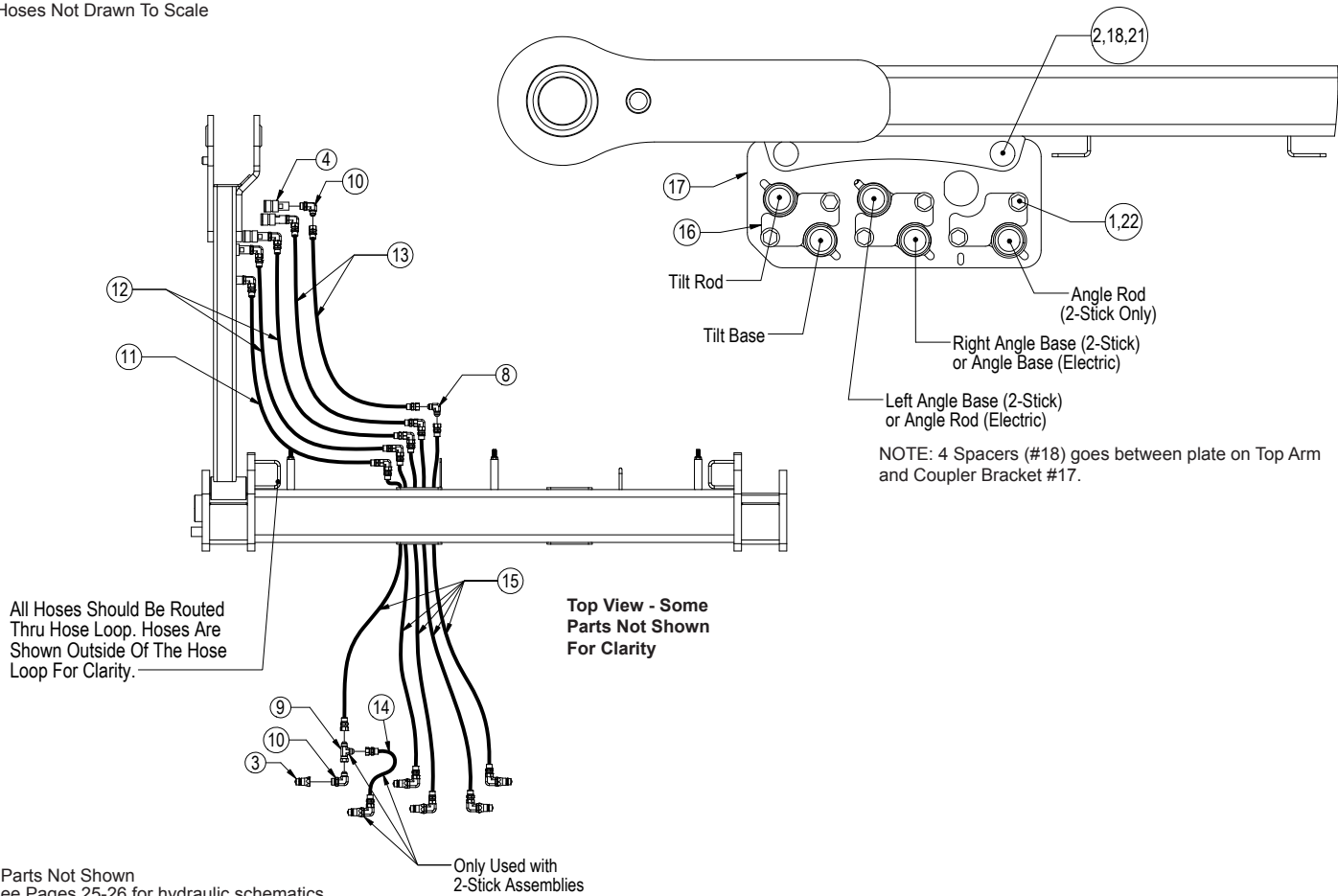

\* Parts Not Shown  
 See Pages 25-26 for hydraulic schematics.  
 Item #A & B for Claas Tractors.  
 Item #C for Steiger, New Holland, Claas and JD 9R Tractors and Item #D for JD 9RX, Versatile and Challenger Tractors.

Item No.	Part No.	Description	Configuration	HAHT - 2 Stick	HAHT	HANT - 2 Stick	HANT	NAHT	NANT
			Qty.	Qty.	Qty.	Qty.	Qty.	Qty.	
1	16-35C612	3/8" x 3/4" Flanged Bolt		6	4	4	2	2	-
2	16-21127	1/2" x 1-3/4" Carriage Bolt Gr 5 NC		2	2	2	2	2	-
3	25-34342	Tappet Quick Coupler Male		6	4	4	2	2	-
4	25-34321	Tappet Quick Coupler Female		5	4	3	2	2	-
5*	25-3401	Pioneer Dust Cap Left Angle (Yellow)		2	-	2	-	-	-
6*	25-3453	Pioneer Dust Cap Tilt (Green)		2	2	-	-	2	-
7*	25-3455	Pioneer Dust Cap Right Angle (Red)		2	2	2	2	-	-
8	31-15199-8-8	JIC Union Elbow 90° (2500-8-8)		5	4	3	2	2	-
9	31-34090	Swivel Nut Run Tee JIC (6602-8-8-8)		1	-	1	-	-	-
10	31-34051	Straight Thread Elbow 90° JIC x O-Ring (6801-8-10)		11	8	7	4	4	-
10A	31-34051	Straight Thread Elbow 90° JIC x O-Ring (6801-8-10)		5	4	3	2	2	-
10B	31-6802-08-10	Straight Thread Elbow 45° JIC x O-Ring (6802-08-10)		6	4	4	2	2	-
11	35-31132	69" x 1/2" -8JIC/-8JIC Hose W/Cordura		1	-	1	-	-	-
12	35-31133	72" x 1/2" -8JIC/-8JIC Hose W/Cordura		2	2	2	2	-	-
13	35-31134	75" x 1/2" -8JIC/-8JIC Hose W/Cordura		2	2	-	-	2	-
14	35-30121	35" x 1/2" -8JIC/-8JIC Hose		1	-	1	-	-	-
15D	35-18953-3200	320" (26.67") x 1/2" -8JIC/-8JIC Hose w/180" Cordura		5	4	3	2	2	-
15C	35-30183	293" (24.42") x 1/2" -8JIC/-8JIC Hose w/165" Cordura		5	4	3	2	2	-
16	44-14734	Female Coupler Retainer		3	2	2	1	1	-
17	44-18180	Female Coupler Mount Bracket		1	1	1	1	1	-
18	44-8490	Spacer Bushing		4	4	4	4	4	-
19*	69-18890	Wire Harness - Valve to Disconnect		-	1	-	1	-	-
20*	69-1531	Wire Harness - Disconnect to Tractor		-	1	-	1	-	-
21	70-20604	1/2" Hex Center Lock Nut NC		2	2	2	2	2	-
22	70-20622	3/8" Flange Hex Nut NC		6	4	4	2	2	-

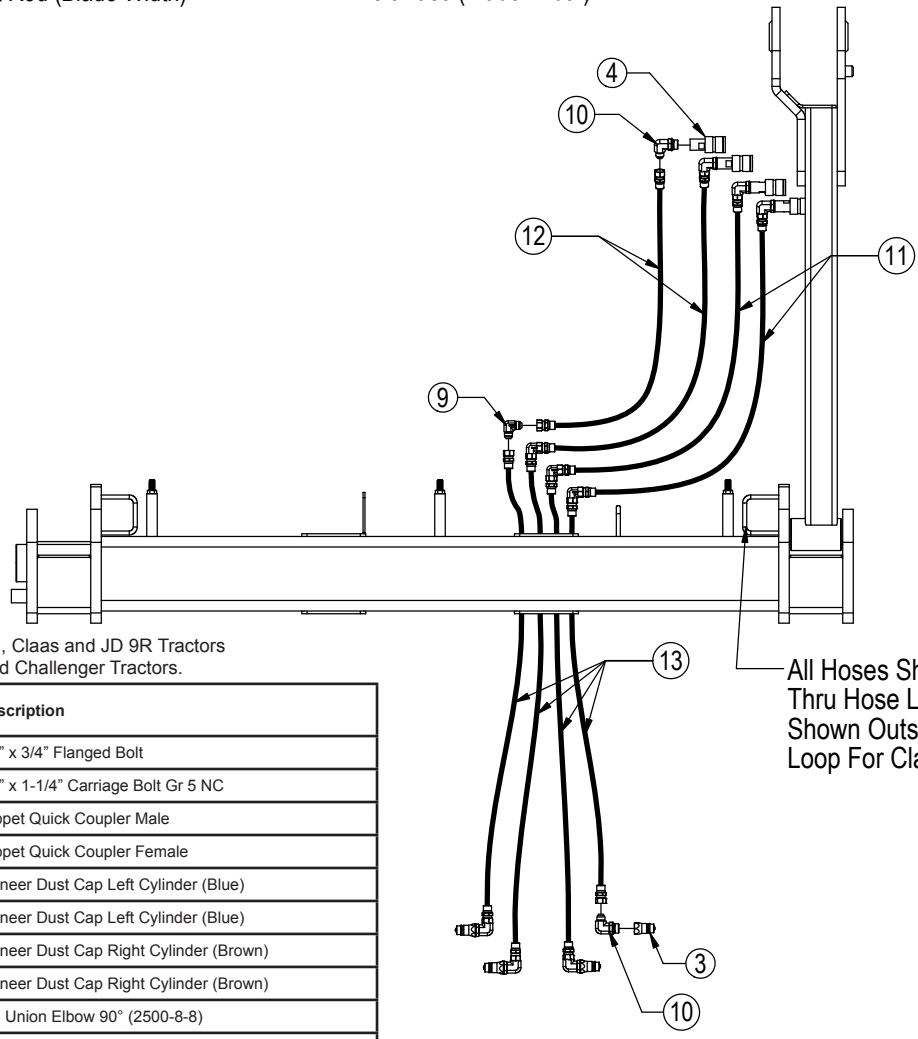
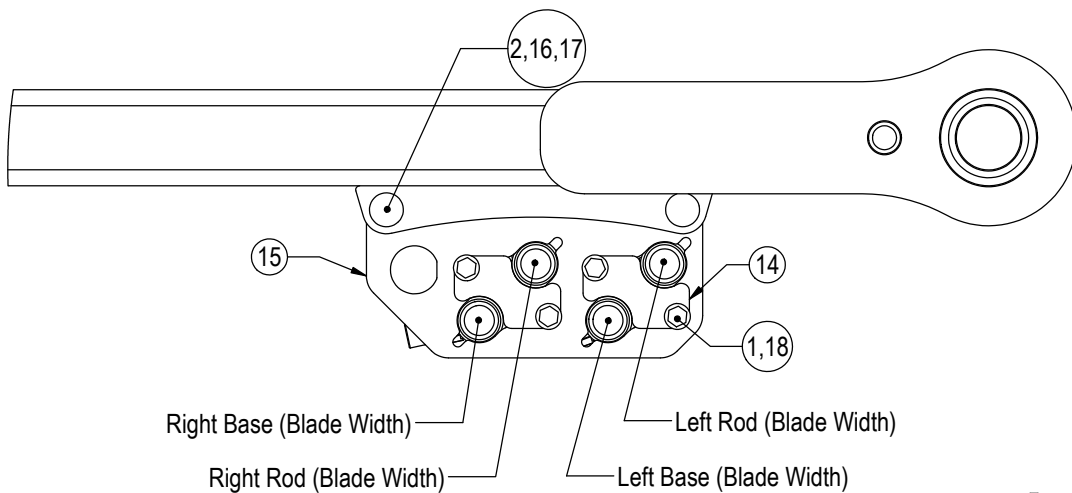

Item #A & B for Claas Tractors.  
 Item #C for Steiger, New Holland, Claas and JD 9R Tractors  
 Item #D for JD 9RX, Versatile and Challenger Tractors.

Item No.	Qty.	Part No.	Description
1	4	16-35C612	3/8" x 3/4" Flanged Bolt
2	2	16-21125	1/2" x 1-1/4" Carriage Bolt Gr 5 NC
3	4	25-34342	Tappet Quick Coupler Male
4	4	25-34321	Tappet Quick Coupler Female
5*	2	25-3403	Pioneer Dust Cap Left Cylinder (Blue)
6*	2	25-3404	Pioneer Dust Cap Left Cylinder (Blue)
7*	2	25-3405	Pioneer Dust Cap Right Cylinder (Brown)
8*	2	25-3406	Pioneer Dust Cap Right Cylinder (Brown)
9	4	31-15199-8-8	JIC Union Elbow 90° (2500-8-8)
10	8	31-34051	Straight Thread Elbow 90° JIC x O-Ring (6801-8-10)
10A	4	31-34051	Straight Thread Elbow 90° JIC x O-Ring (6801-8-10)
10B	4	31-6802-08-10	Straight Thread Elbow 45° JIC x O-Ring (6802-08-10)
11	2	35-31133	72" x 1/2" -8JIC/-8JIC Hose W/Cordura
12	2	35-31134	75" x 1/2" -8JIC/-8JIC Hose W/Cordura
13D	4	35-18953-3200	320" (26.67") x 1/2" -8JIC/-8JIC Hose w/180" Cordura
13C	4	35-30183	293" (24.42") x 1/2" -8JIC/-8JIC Hose w/165" Cordura
14	2	44-14734	Female Coupler Retainer
15	1	44-16236	Female Coupler Mount Bracket
16	4	44-8490	Spacer Bushing
17	2	70-20604	1/2" Hex Center Lock Nut NC
18	4	70-20622	3/8" Flange Hex Nut NC

# Initial Startup Instructions

---

---

Prior to operating the blade system, all air must be purged from the hydraulic system. Follow the steps below for each function on your blade.

## ***Lift Function:***

1. With the lift frame down and blocked, loosen the fittings on both ends of the lift cylinders.
2. Actuate the raise function to supply oil to the rod end of the cylinders.
3. When oil starts to flow from the fittings, stop oil flow, and tighten the fitting on the rod end of the lift cylinders.
4. Continue to flow oil until the system is fully raised and then block the lift frame.
5. Actuate the function in the opposite direction to supply oil to the base end of the lift cylinders.
6. When all air is removed from the lift system, stop oil flow and tighten the fittings on the base end of the lift cylinders.
7. Raise lift system and remove blocks. Cycle up and down 5 more times.
8. Check tractor oil level and fill if necessary.
9. Continue with connecting the blade on Page 8.

## ***Blade Width Function:***

1. Loosen the fittings on the rod and base end of the blade width cylinders.
2. Actuate the function to extend the right cylinder and supply oil to the base end.
3. When oil starts to flow from the fitting, stop oil flow, and tighten the fitting on the base end of the right cylinder.
4. Fully extend the right cylinder.
5. Actuate the function in the opposite direction to supply oil to the rod end of the right cylinder.
6. When all air is removed from the system, stop oil flow and tighten the fitting on the rod end of the right cylinder.
7. Repeat Steps 2-7 for the left cylinder.
8. Cycle both cylinders in and out 5 more times.
9. Check tractor oil level and fill if necessary.

## ***Tilt Function:***

1. Use a lift or jack to tilt the blade system until the left side is fully up, loosen the fittings on the rod and base end of both tilt cylinders.
2. Actuate the tilt function to extend the right tilt cylinder and supply oil to the base end of the right cylinder and to the rod end of the left cylinder.
3. When oil starts to flow from the fittings, stop oil flow, and tighten the fitting on the base end of the right cylinder and rod end of the left cylinder.
4. Remove the lift or jack.
5. Continue to actuate the tilt function until oil flows out of the remaining open ports.
6. Actuate the tilt function in the opposite direction.
7. When all air is removed from the tilt system, stop oil flow, and tighten the remaining fittings on the cylinders.
8. Cycle both cylinders in and out 5 more times.
9. Check tractor oil level and fill if necessary.

## ***Angle Function (2-Lever System):***

1. Loosen the fittings on the rod and base end of the left angle cylinder.
2. Actuate the angle function to extend the left angle cylinder and supply oil to the base end of the left cylinder.
3. When oil starts to flow from the fittings, stop oil flow, and tighten the fitting on the base end of the left cylinder.
4. Continue to actuate the left angle function until oil flows out of the remaining open ports on the left cylinder.
5. Actuate the left angle function in the opposite direction.
6. When all air is removed from the left angle system, stop oil flow, and tighten the remaining fittings on the left angle cylinder.
7. Repeats Steps 1-6 for the right angle cylinder
8. Cycle the left cylinder in and out 5 more times and then the right cylinder in and out 5 more times.
9. Check tractor oil level and fill if necessary.

Run the blade through all the functions. If any function does not operate correctly, refer to corresponding section above and re-bleed. If problem still persists, call Grouser Products.

**NOTE: If blade does not function to the operator's liking or preferred direction, swap the couplers at the rear of the tractor or control the function location in the cab.**



# Connecting and Disconnecting the Blade

## To Connect:

1. Lift the locking latch and pull the quick attach lock handle on the left side of the angle system to open the quick attach system. Refer to Page #16-17 for further clarification on the quick attach system.
2. Drive the tractor forward slowly until the top edge of the male quick attach is under the top hook of the female quick attach already on the blade assembly.
3. Raise the lift system until the male quick attach engages the female. Continue to raise the lift system until the blade is off the ground and the female quick attaches are against the front of the male quick attaches.
4. Shut off the tractor engine and set the parking brake.
5. Push the quick attach lock handle and lift the locking latch to lock the handle in place.
6. Connect hydraulics couplers on the top arm. Refer to Page #6 for proper locations of all functions.
7. If applicable, plug the male blade break away end of the wire harness into the female blade break away end of the wire harness on the top arm.
8. Refer to the Initial Startup Instructions on Page 7 before operating any function on the blade.

## To Disconnect:

1. Place a block under the cutting edge to provide the proper blade angle for disconnecting the quick attach. You will need about 5-6" of height.
2. Set the blade on the ground.
3. Unhook all of the couplers on the top arm.
4. Lift the locking latch and pull the quick attach lock handle to unlock the quick attach system.
5. Slowly lower the lift system to disengage the blade.
6. Slowly back away from the blade. When lift system is clear from the blade, raise the lift system.

# Skid Shoe and Tilt Plate Adjustment

## Skid Shoe Adjustment:

1. Remove the handle from the ratchet keeper by pulling the hitch clip pin and insert into the handle on the ratchet jack.
2. Loosen the locking nut on the ratchet jack.
3. Hold the body of the ratchet jack and rotate the ratchet jack handle to raise or lower the skid shoes.
4. If the skid shoe is not moving in the proper direction, move the forward/reverse lever on the handle (see Figure 2). Rotate the ratchet jack handle again to move the skid shoe in the direction needed.
5. After skid shoe is adjusted, rotate the ratchet jack handle until it rests up against the ratchet keeper. Return the removable handle to the ratchet keeper ensuring that the ratchet jack handle is captured by the removable handle and the ratchet keeper. Secure the handle to the ratchet keeper with a hitch clip pin.
6. Tighten the locking nut against the ratchet jack body to keep it from moving.
7. When skid shoes are worn, replace with new skid shoes.

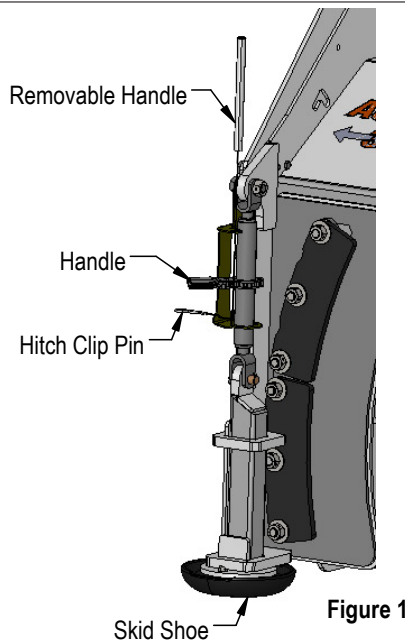

## Tilt Plate Adjustment:

1. Remove nuts and each tilt plate separately.
- Note: Don't remove all of the nuts at the same time.
2. Install or remove washers as needed to adjust tilt-way clearance to have 1/16" - 1/8" of clearance.
  3. Once the tilt-way clearance is set, tighten nuts to 640 ft-lbs.

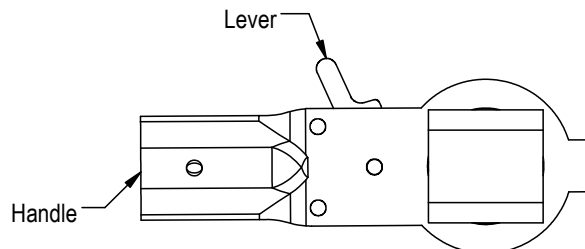

# Blade Assembly

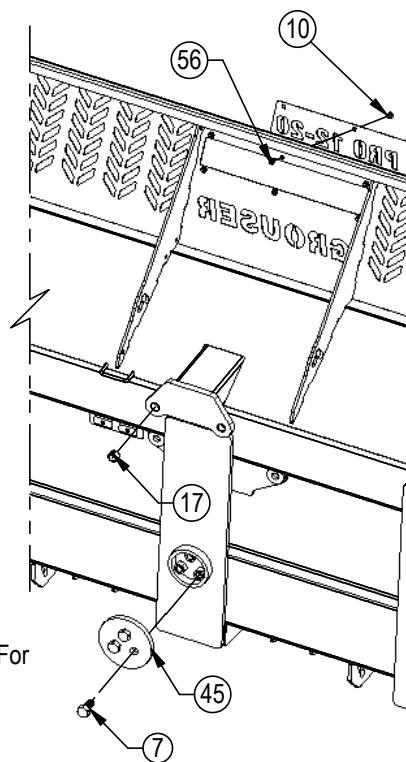
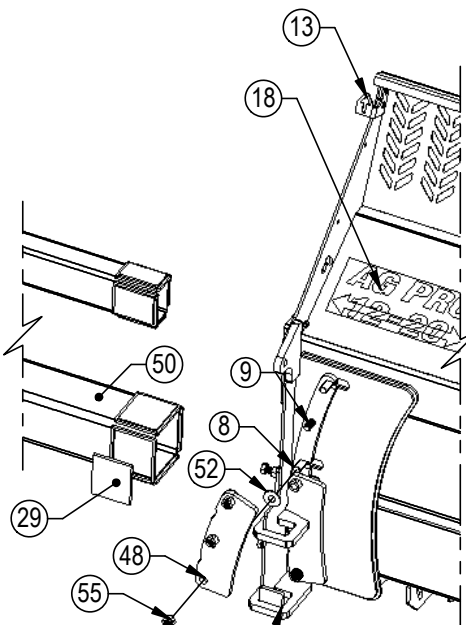
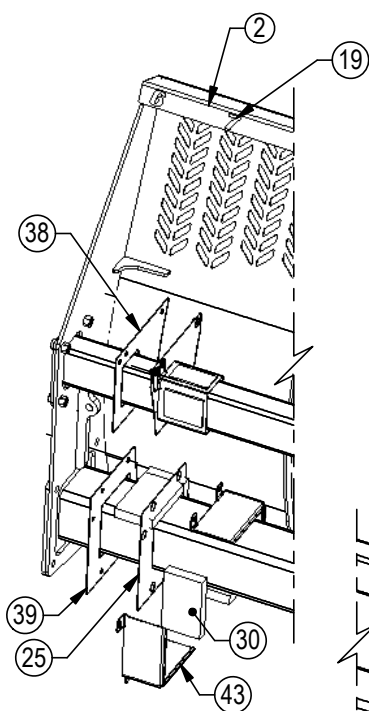

Left Side Skid Shoe Assembly Not Shown For Clarity.

Item No.	Qty.	Part No.	Description
1	1	15-17570	12-20 XAXT (V6) - Blade Weld
2	1	15-16855-L	12-20 Blade End Weld Left
3	1	15-16855-R	12-20 Blade End Weld Right
4	12	16-16305	3/8 x 1.25" Flanged Elevator Bolt
5	4	16-20517	3/4" x 4-1/2" Hex Bolt Gr 8 NC
6	18	16-20538	7/8" x 2" Hex Bolt Gr 8 NC
7	3	16-20558	1" x 2" Hex Bolt Gr 8 NC
8	8	16-20560	1" x 2-1/2" Hex Bolt Gr 8 NC
9	4	16-20562	1" x 3" Hex Bolt Gr 8 NC
10	10	16-21064	3/8" x 1" Carriage Bolt Gr 5 NC
11	4	16-21666	5/8" x 1-3/4" Plow Bolt Gr 5 NC
12	42	16-21748	3/4" x 2" Plow Bolt Gr 5 NC
13	1	18-16304-L	Bracket, Location Left 12-20 Slider
14	1	18-16304-R	Bracket, Location Right 12-20 Slider
15*	1	18-18595-L	Ratchet Keeper - Left
16	1	18-18595-R	Ratchet Keeper - Right
17	2	19-7774	1" x 1" Spring Bushing (125100100)
18	1	27-15598	Ag Pro 12-20 Decal
19	1	27-15612-L	Ag Pro 12-20 Width Decal - Left
20	1	27-15612-R	Ag Pro 12-20 Width Decal - Right
21	3	29-11118-5	5' - 3/4" x 8" Cutting Edge (4500, 6500)
22	1	29-11118-6	6' - 3/4" x 8" Cutting Edge (4500, 6500)
23	6	34-16158	Bearing, 2.625 x 6.00 W/ Holes
24	2	34-16419	12-20 Top Seal
25	1	34-16420	12-20 - 8" Tube Seal - Bottom Left
26	1	34-16421	12-20 - 10" Tube Seal - Bottom Right
27	8	34-16425	12-20 Top Narrow UHMW
28	8	34-16426	12-20 Top Wide UHMW
29	4	34-16427	12-20 8" Inner UHMW
30	4	34-16428	12-20 8" Outer UHMW

Item No.	Qty.	Part No.	Description
31	8	34-16429	12-20 10" UHMW
32	2	34-17565	Ratchet Jack
33	12	44-16977	12-20 Standoff Shim
34	2	44-16525	12-20 Standoff (1.25" x 2")
35*	1	44-15600	12-20 Custom Name Plate - (6.2" x 25.6")
36	1	44-15605	Ag Pro 12-20 Name Plate - (6.2" x 25.6")
37	1	44-16401	12-20 Plate, Top Cover Right
38	1	44-16402	12-20 Plate, Top Cover Left
39	1	44-16403	12-20 Plate, 8" Cover
40	1	44-16404	12-20 Plate, 10" Cover
41	2	44-16417	12-20 Plate, Slider
42	4	44-16422	12-20 Top Outer Retainer
43	2	44-16423	12-20 8" Outer Retainer
44	2	44-16424	12-20 10" Outer Retainer
45	1	44-3749	Backdrag Brace Plate
46	2	50-15458	12" Round Mushroom Skid Shoe
47	2	50-17580	12-20 Skid Shoe Mount - Mushroom
48	4	52-18299	12-20 Tilt Plate (Painted)
49	2	53-16990	12-20 Tube Weld - 4x6
50	1	53-16408	12-20 Tube Weld - 8x8
51	1	53-16410	12-20 Tube Weld - 10x10
52	12	57-20749	1" Flat Washer
53	22	70-20584	1/2" Hex Nut Gr 5 NC
54	18	70-20598	7/8" Hex Nut Gr 8 NC
55	12	70-20609	1" Hex Center Lock Nut Gr 2 NC
56	22	70-20622	3/8" Flange Hex Nut Gr 5 NC
57	4	70-20646	5/8" Hex Top Lock Nut Gr 5 NC
58	42	70-20647	3/4" Hex Top Lock Nut Gr 5 NC
59	22	70-20804	1/2" Jam Nut

Use as many Shims (Item #33) as necessary

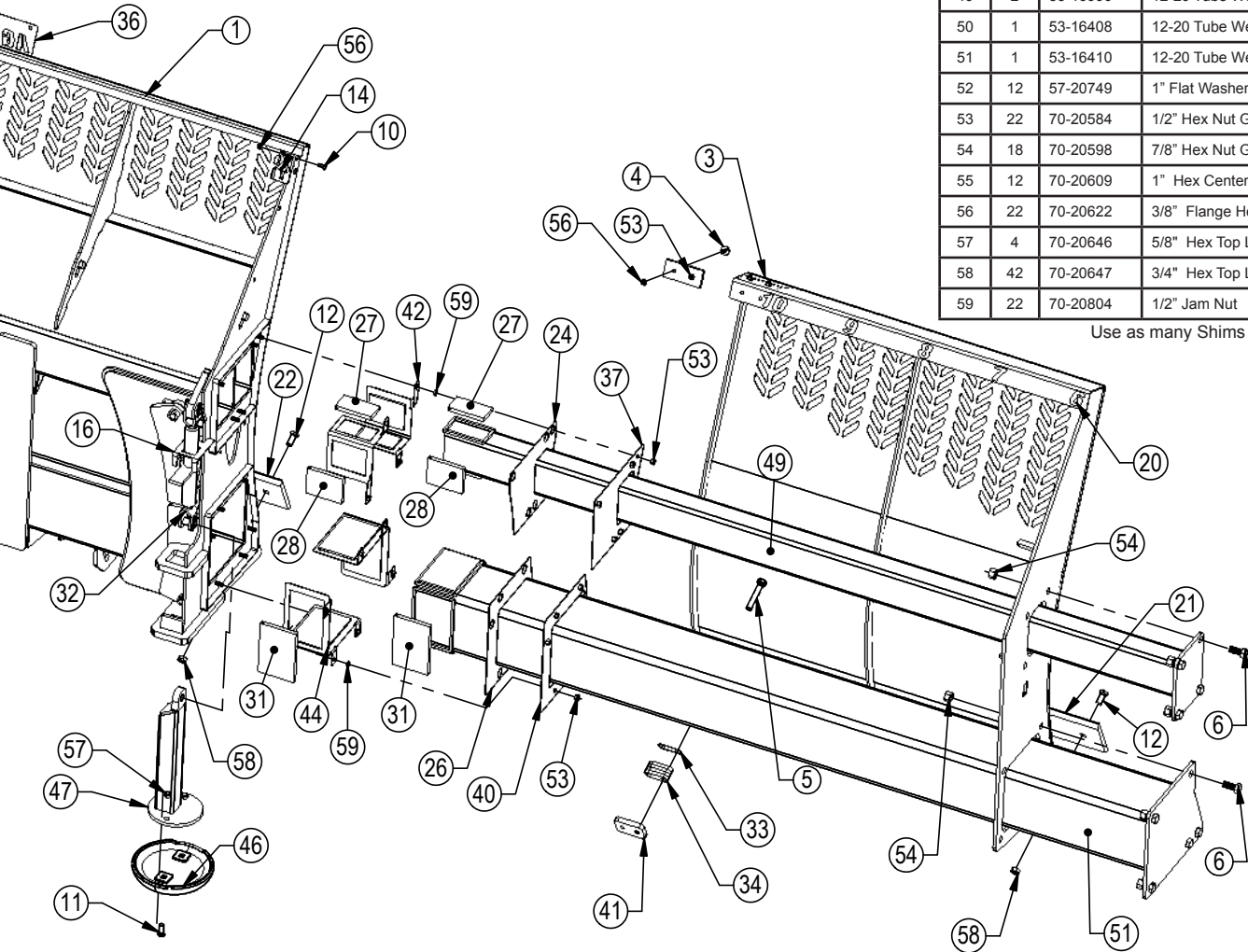

# Hydraulic Angle System Operating Instructions

---

---

If your Grouser blade was purchased with the Hydraulic Angle Option, you will have the ability to angle the blade 30 degrees left or right. To achieve these angles, the two cylinders are designed to operate independently of each other through an electric diverter valve. To angle the blade to the left, actuate the tractor hydraulic control lever in the cab with the diverter valve un-powered. To angle the blade to the right, apply power to the diverter valve and then actuate the tractor hydraulic control lever.

## 2-Lever Angle System Operating Instructions

---

---

If your Grouser blade was purchased with the 2-Lever Hydraulic Angle Option, you will have the ability to angle the blade 30 degrees left or right. To achieve these angles, the two cylinders are designed to operate independently of each other with the use of 2 tractor hydraulic control levers and a safety relief valve. To angle the blade to the left or right, actuate the tractor hydraulic control lever corresponding to the left or right cylinder.

The safety relief valve allows the cylinder to retract if its internal pressure exceeds 2,000 psi. With this safety feature in place, when either cylinder reaches the end of its stroke, the safety relief valve will reroute pressure to the opposite cylinder causing it to extend. Refer to the Relief Valve Instructions below for possible adjustments.

## Relief Valve Instructions

---

---

**Set the safety relief valve at a higher pressure than tractor:** To increase the pressure of the relief valve, install a 0-5,000 psi pressure gauge into the base end of right angle cylinder (see page 30). Loosen the jam nut on the safety valve and tighten the Allen screw 1/2 turn. Next, extend the right side cylinder out until the safety valve activates, while the safety valve is in function, record the pressure reading on the gauge. Continue to tighten the Allen screw in 1/2 turn increments and record the pressure until a high enough relief setting is obtained. **Do not exceed the 3,000-psi operating pressure of the cylinders.** Tighten the jam nut and remove the gauge.

**Automatic lever release:** In certain newer model tractors, the hydraulic control lever will automatically release and instantly stop oil flow once the end of the stroke is reached.

**CAUTION: Do not bypass the safety relief valve and plumb each cylinder to separate valves on the tractor.**

To ensure proper use and life of equipment, it is recommended to have both cylinders closed for straight ahead dozing and only one cylinder partially or fully extended for angled dozing as shown in the diagrams below. **If the angle system is not used correctly, frame damage may occur.** Some damaged frames can be repaired, please contact Grouser Products for repair instructions if needed.

**Please contact Grouser Products with any questions by:**  
Phone - 701-282-7710 or 800-747-6182; Fax - 701-282-8131

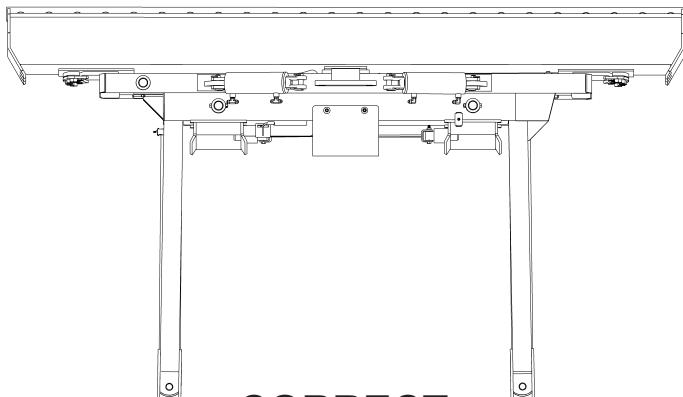

**CORRECT**

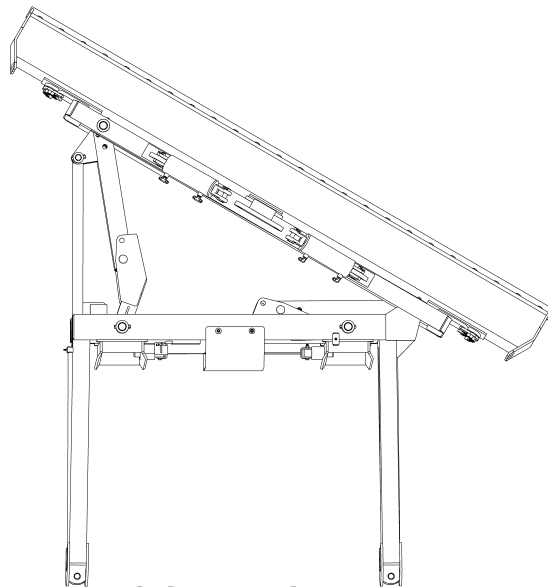

**CORRECT**  
(Left or Right)

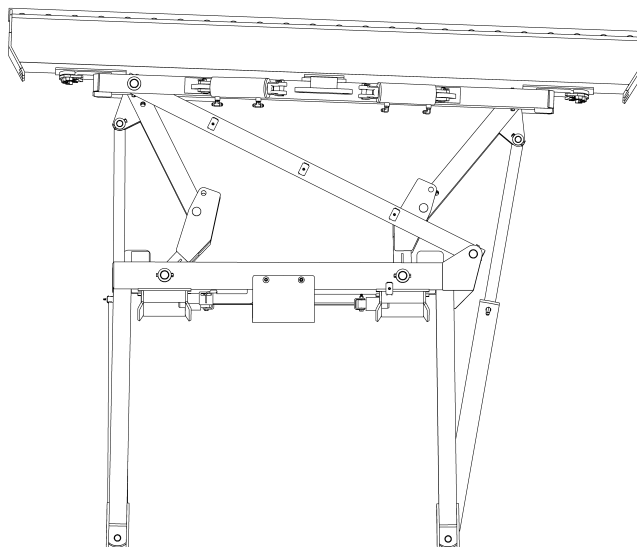

**INCORRECT**

Item No.	Qty.	Part No.	Description
1	4	16-20128	1/2" x 2" Hex Bolt Gr 5 NC
2	4	16-35C612	3/8" x 3/4" Flanged Bolt
3	1	18-14658	NAXT Center Bracket
4	4	19-13577	NR Pin Spacer Clevis End
5	2	19-7774	1" x 1" Spring Bushing
6	2	26-34711	4 x 8 Cylinder w/ Cast Clevis Ends
7	1	32-16980	12-20 NAHT Tilt Frame
8	4	43-13580	1" Clevis Bolt In Pin
9	8	57-20744	1/2" Flat Washer
10	4	70-20604	1/2" Hex Center Lock Nut Gr 2 NC

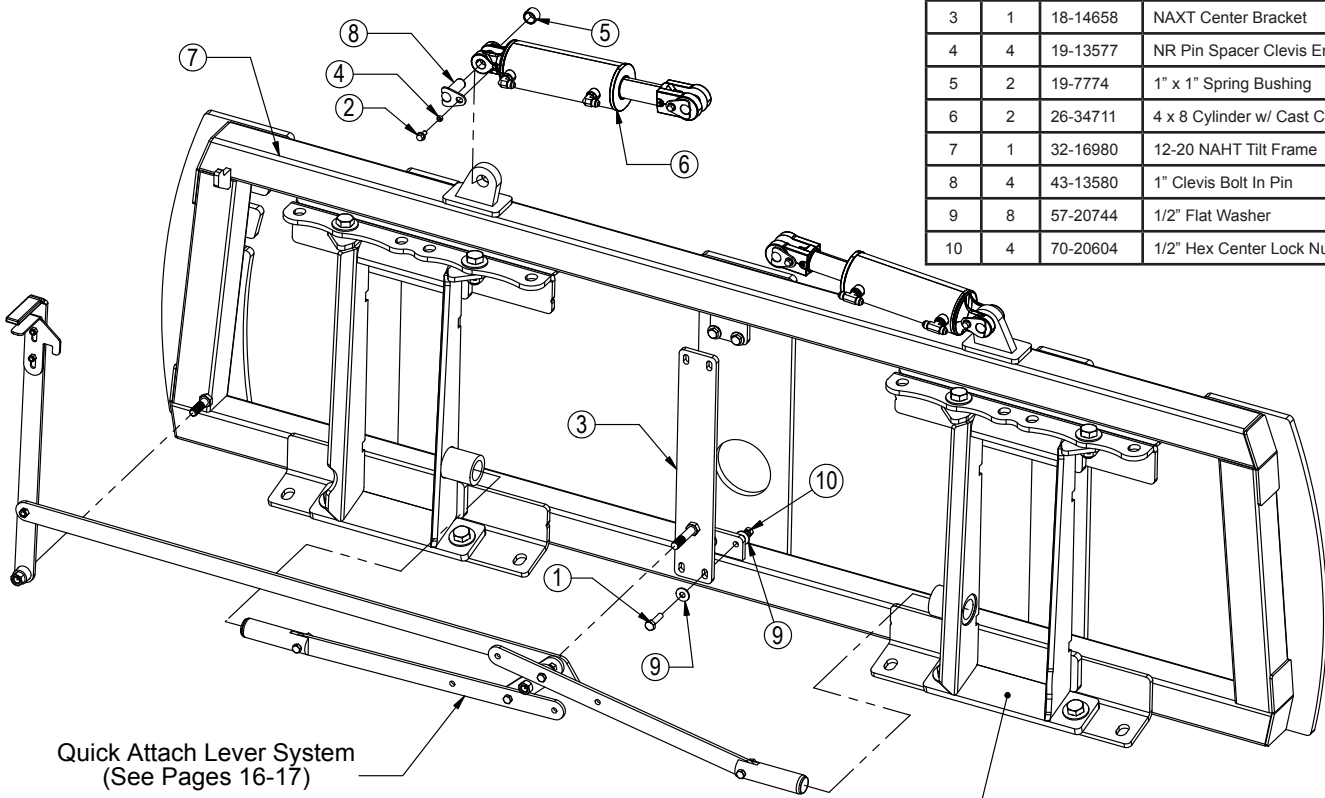

Quick Attach Lever System  
(See Pages 16-17)

Quick Attach (See Pages 16-17)

Item No.	Qty.	Part No.	Description
1	1	15-17590	NANT - Blade Weld 12-20 Slider (V6)
2	18	16-20542	7/8" X 3" Hex Bolt Gr 5 NC
3*	2	44-16470	Box End Plate 12-20 Slider
4	2	44-16480	Silage Box End Plate 12-20 Slider
5	18	57-20758	7/8" SAE Hardened Flat Washer - 1-3/4" OD
6	18	70-20598	7/8" Hex Nut Gr 8 NC

\* Parts Not Shown

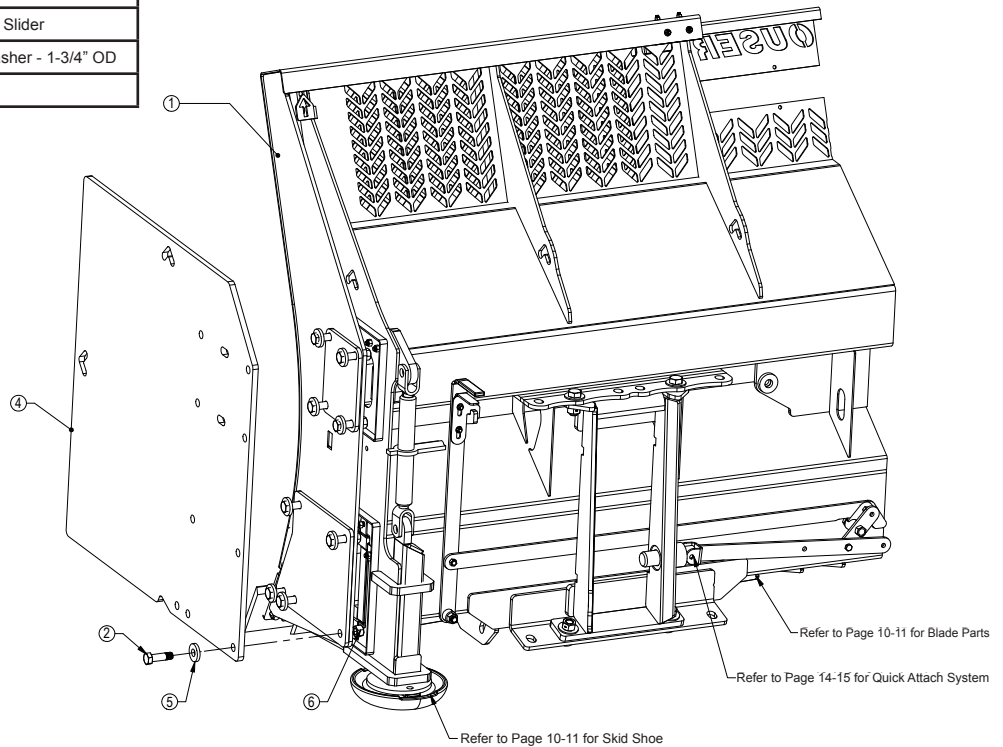

Hoses Not Drawn To Scale

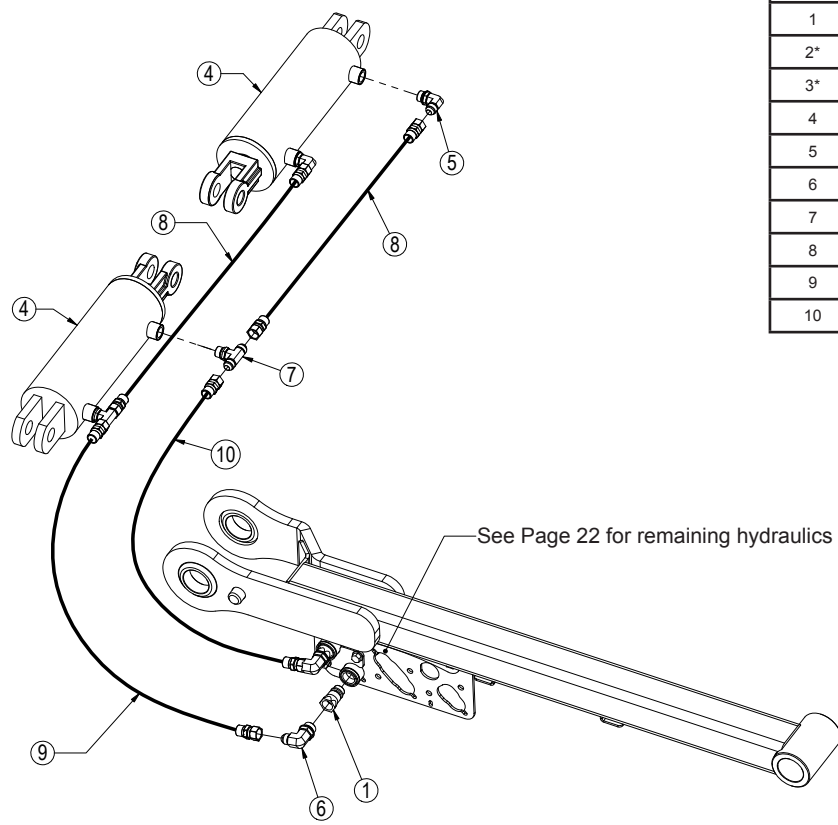

Item No.	Qty.	Part No.	Description
1	2	25-34342	Tappet Quick Coupler Male
2*	2	25-3453	Pioneer Dust Cap Tilt (Green)
3*	2	25-3454	Pioneer Dust Plug Tilt (Green)
4	2	26-34711	4 x 8 Cylinder W/ Cast Clevis Ends
5	2	31-34050	Straight Thread Elbow 90° JIC x O-Ring (6801-8-8)
6	2	31-34051	Straight Thread Elbow 90° JIC x O-Ring (6801-8-10)
7	2	31-34060	Branch Tee JIC x O-Ring (6803-8-8-8)
8	2	35-30022	39" x 3/8" -8JIC/-8JIC Hose
9	1	35-31184	37" x 1/2" -8JIC/-8JIC Hose w/ Cordura (3.5M)
10	1	35-31185	47" x 1/2" -8JIC/-8JIC Hose w/ Cordura (3.5M)

\* Parts Not Shown

NOTE: When ordering cylinder seal kits, the part number on the cylinder is needed. The number is stamped on the base end of the cylinder opposite of the hydraulic ports.

No. On Cylinder	Part No.	Description
26-34711	49-12271	Seal Kit 4 x 8 (647135) Nitrided Rod, Clevis Ends

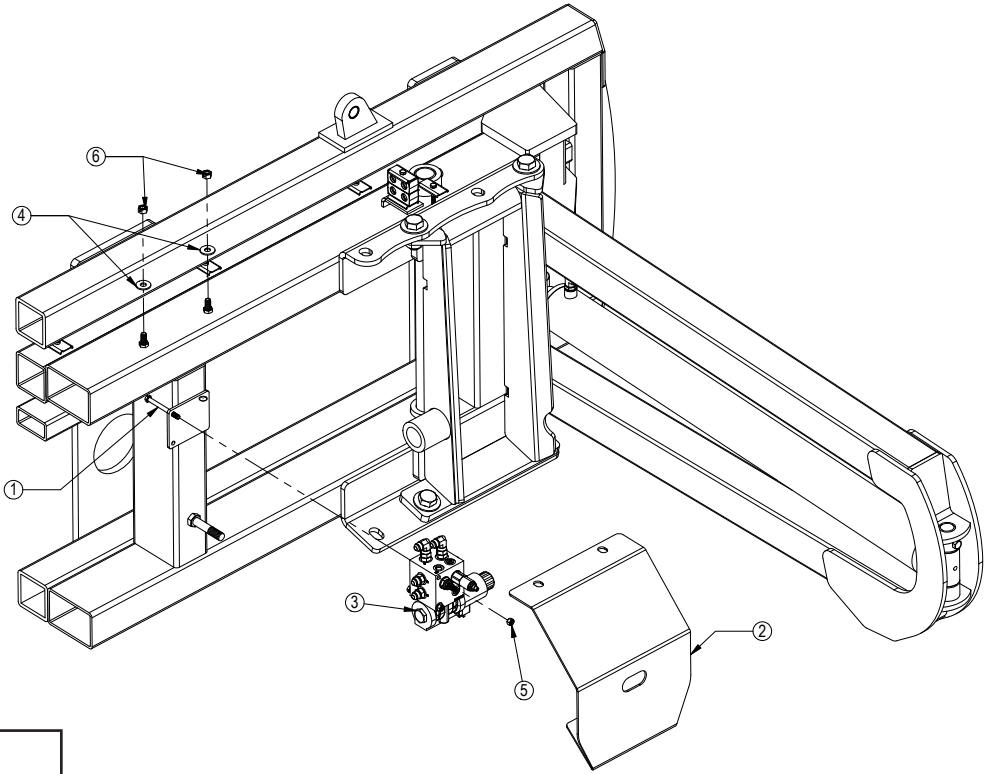

Item No.	Qty.	Part No.	Description
1	2	16-20077	3/8" x 4-1/2" Hex Bolt Gr 5 NC
2	1	18-1701	AG Pro Hydraulic Valve Cover
3	1	56-13305	Hydraulic Angle Valve
4	2	57-20744	1/2" Flat Washer
5	2	70-20582	3/8" Hex Nut
6	2	70-20604	1/2" Hex Center Lock Nut Gr 2 NC

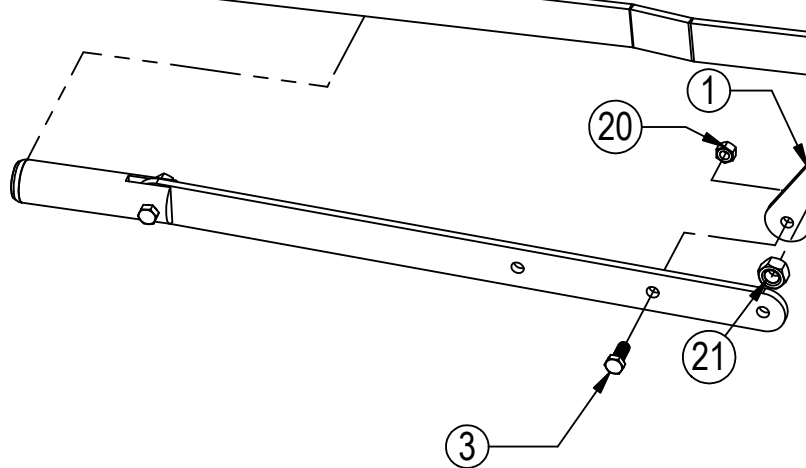
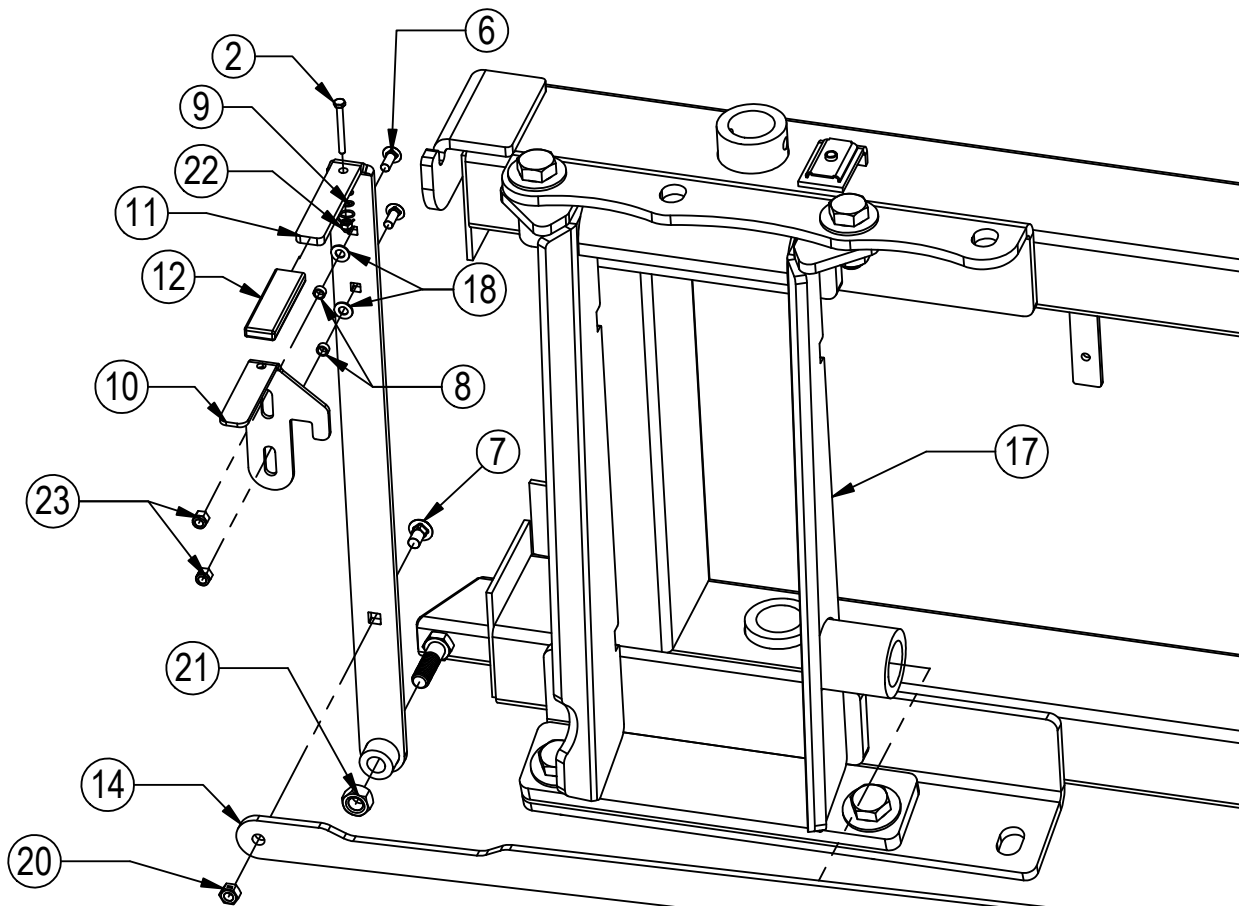

Some Parts Hidden For Clarity

Item #A for HAHT & HANT and Item #B for NAHT & NANT

Item No.	Qty.	Part No.	Description
1	1	11-3049	Bell Crank Weld
2	1	16-20040	5/16" x 2-1/2" Hex Bolt Gr 5 NC
3	3	16-20125	1/2" x 1-1/4" Hex Bolt Gr 5 NC
4	2	16-20132	1/2" x 3" Hex Bolt Gr 5 NC
5	8	16-20560	1" x 2-1/2" Hex Bolt Gr 8 NC
6	2	16-21064	3/8" x 1" Carriage Bolt
7	1	16-21125	1/2" x 1-1/4" Carriage Bolt
8	2	19-13577	NR Pin Spacer Clevis End
9	1	34-17799	Pin Pulling Latch Spring
10	1	39-14663	AG Pro Pin Puller Latch
11	1	39-14665	AG Pro Pin Puller Handle Weld
12	1	39-3072	Handle Cover (Orange)
13	2	43-3050	QA Lock Pin
14A	1	44-14709	Pin Puller Link Plate
14B	1	44-14662	Pin Puller Link Plate
15	1	45-14710-R	Female Bolt On Quick Attach, Right
16	1	45-14710-L	Female Bolt On Quick Attach, Left
17	2	57-20742	3/8" Flat Washer
18	16	57-20819	1" Flat Washer Heavy Duty Gr 8 (USS)
19	6	70-20604	1/2" Hex Center Lock Nut Gr 2 NC
20	2	70-20607	3/4" Hex Center Lock Nut Gr 2 NC
21	8	70-20609	1" Hex Center Lock Nut Gr 2 NC
22	1	70-20611	5/16" Nyloc Hex Nut Gr 5 NC
23	2	75-14655	AG Pro Pin Puller Link Weld
24	2	70-20622	3/8" Flange Nut



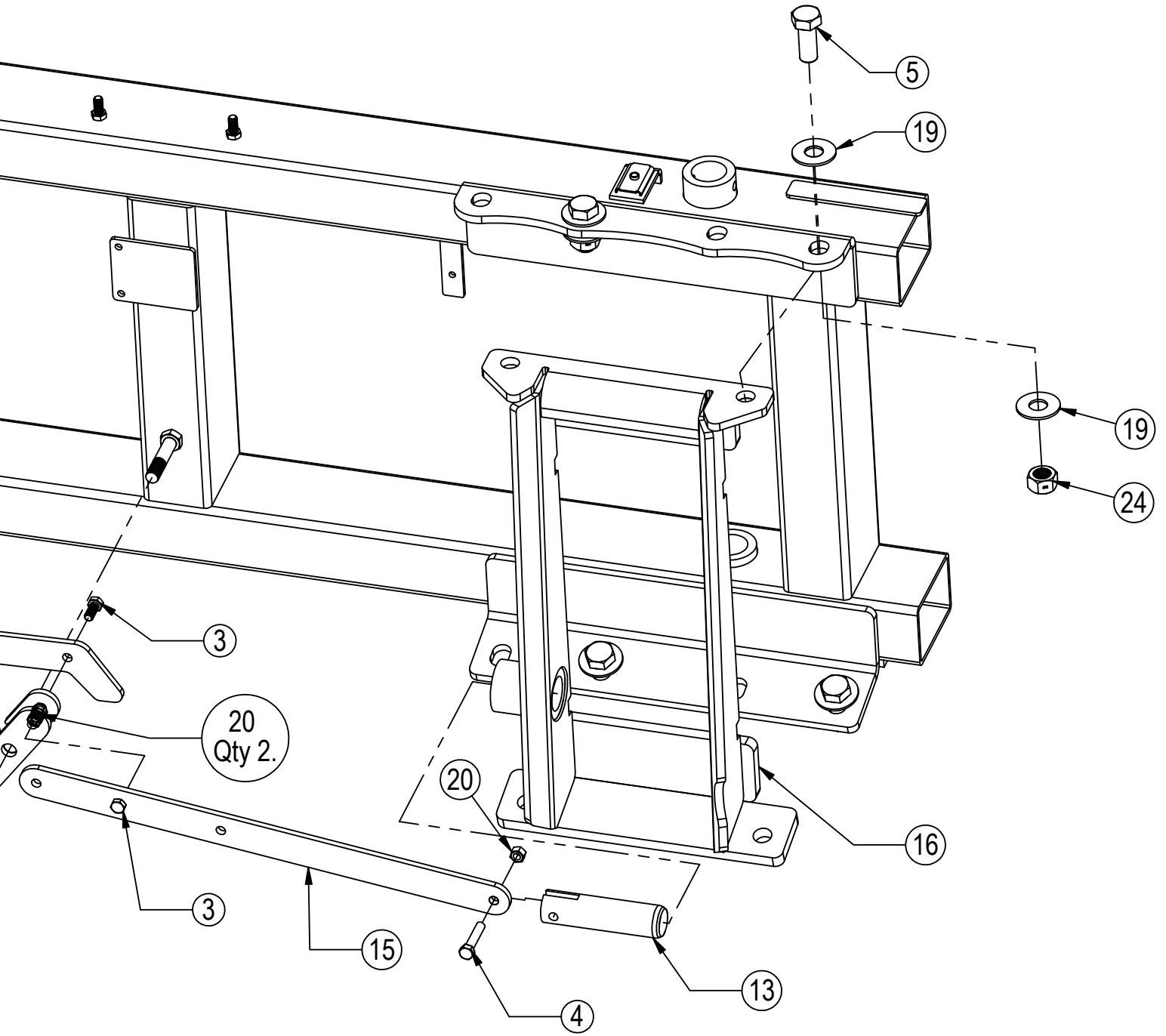

**Hydraulic Angle - Hydraulic Tilt Or Hydraulic Angle - No Tilt**

Item No.	Qty.	Part No.	Description
1	1	11-5055	Stabilizer Arm
2	1	11-8082	Angle Arm Right
3	1	11-9039	Angle Arm Left
4	1	14-9366	Non Tilt Bar
5	4	16-20132	1/2" x 3" Hex Bolt Gr 5 NC
6	2	16-20424	1/2" x 3-1/2" Hex Bolt Gr 8 NC
7	3	16-20427	1/2" x 4-1/2" Hex Bolt Gr 8 NC
8	2	16-20564	1" x 3-1/2" Hex Bolt Gr 8 NC
9	4	16-35C612	3/8" x 3/4" Flanged Bolt
10	2	19-7774	1" x 1" Spring Bushing
11	4	19-13577	NR Pin Spacer Clevis End
12	2	26-34711	4 x 8 Cylinder W/ Cast Clevis Ends
13	2	26-34725	4 x 43.5 Cylinder Tube Ends, Top Port
14	1	32-18900	Angle Frame
15	1	32-16975	HA Tilt Frame
16	1	43-8130	1-15/16" x 23-1/4" Pin
17	2	43-8131	1-15/16" x 31" Pin
18	1	43-8132	1-15/16" x 35-1/2" Pin
19	1	43-8133	1-15/16" x 7-1/8" Stabilizer Arm Pin

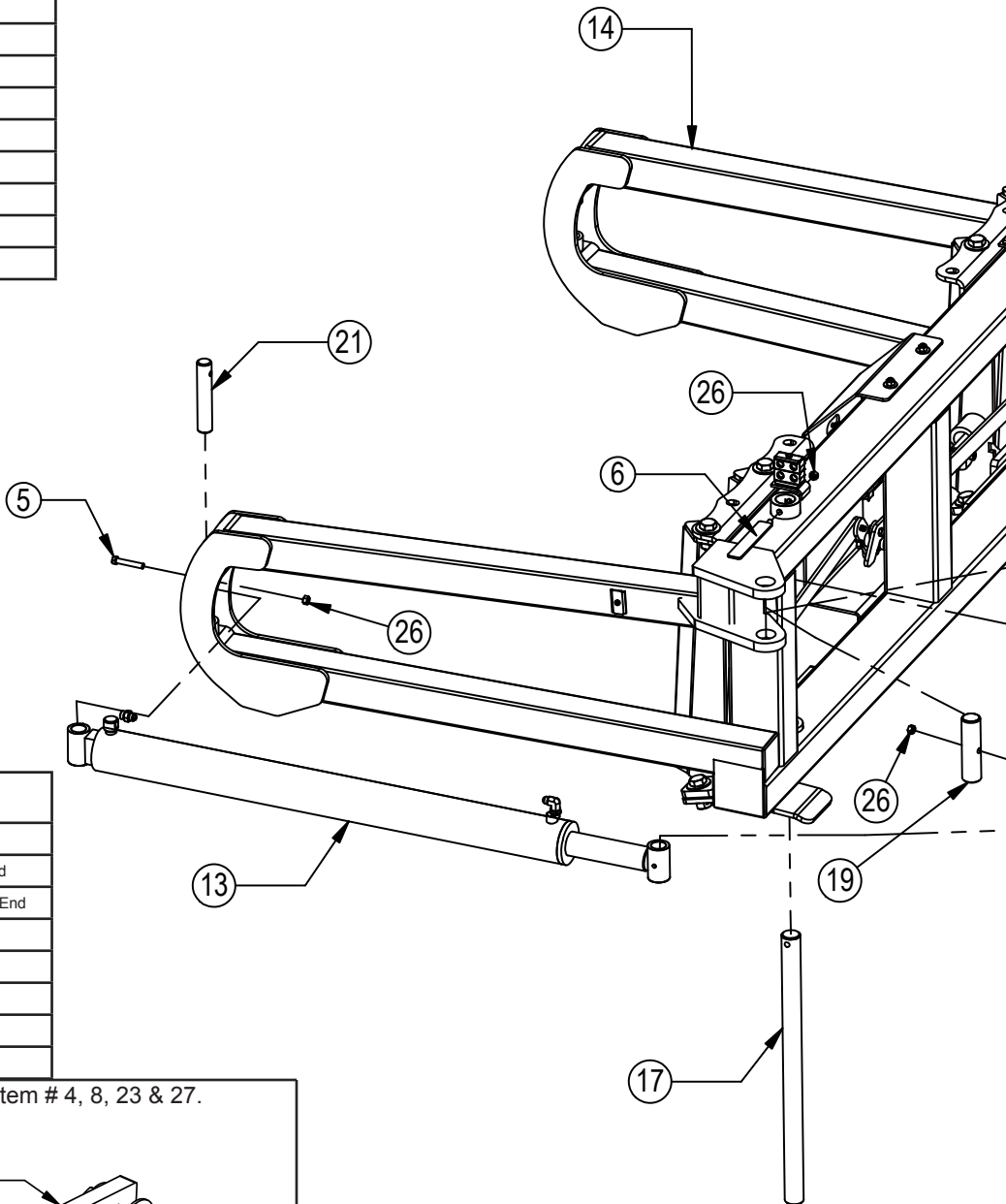

Item No.	Qty.	Part No.	Description
20	4	43-13580	1" Clevis Bolt In Pin
21	2	43-8134	1-1/2" x 8" Angle Cylinder Pin Base End
22	2	43-9352	1-1/2" x 7-1/2" Angle Cylinder Pin Rod End
23	4	57-20749	1" Flat Washer
24	2	58-9371	Grease Zerk 1/8" NPT 45°
25	6	58-9372	Grease Zerk 1/8" NPT 90°
26	9	70-20604	1/2" Hex Center Lock Nut Gr 2 NC
27	2	70-20609	1" Hex Center Lock Nut Gr 2 NC

HANT - Replace item # 9, 10, 11, 12 & 20 with item # 4, 8, 23 & 27.

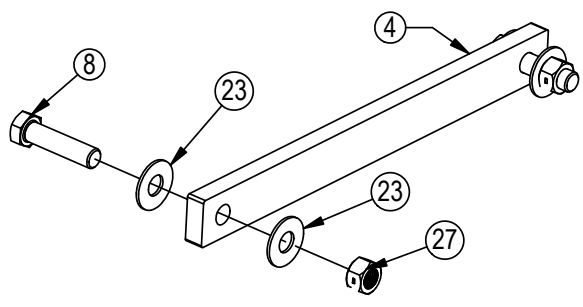

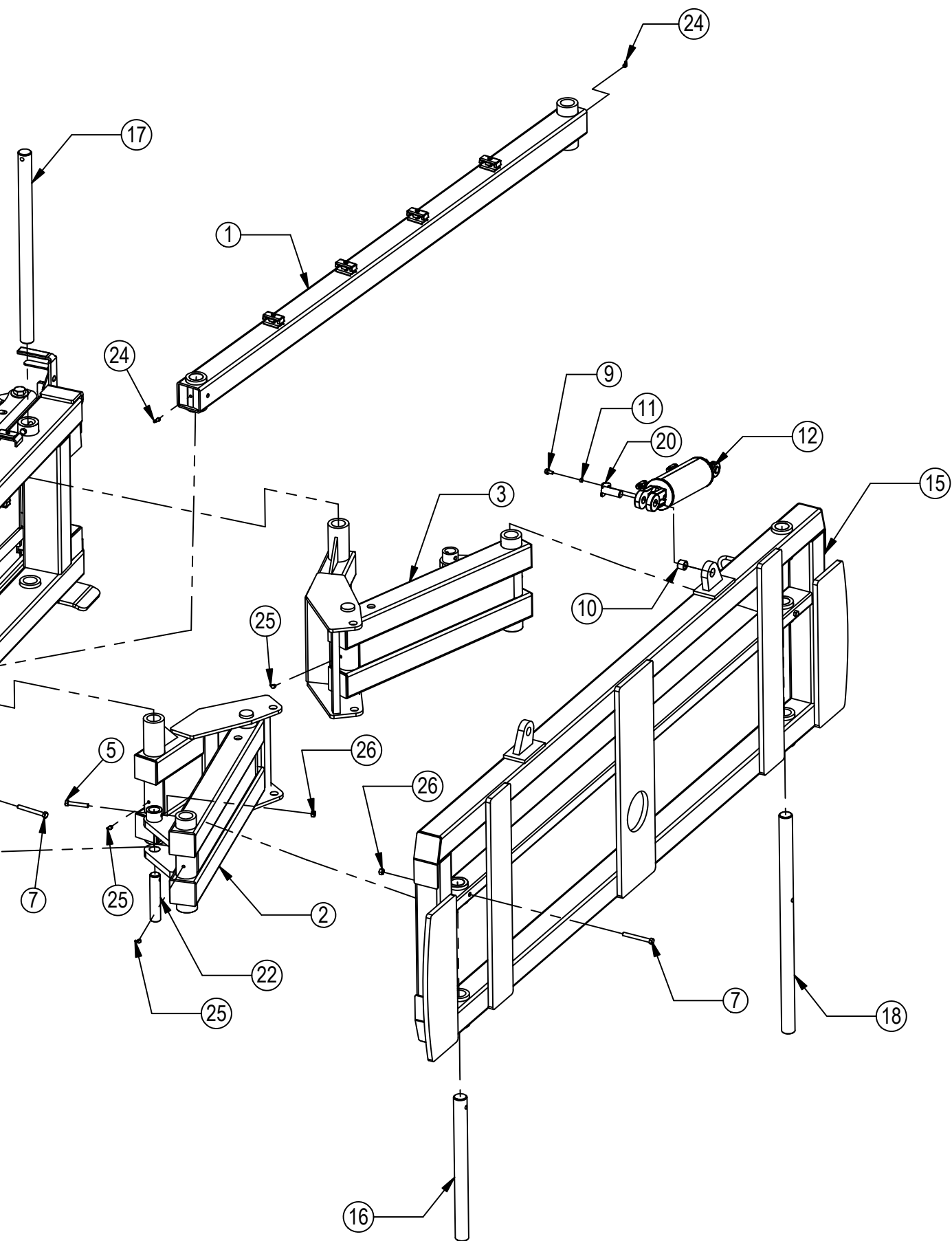

**Hydraulic Angle - Hydraulic Tilt Or Hydraulic Angle - No Tilt Hose Routing**

Hoses Not Drawn To Scale

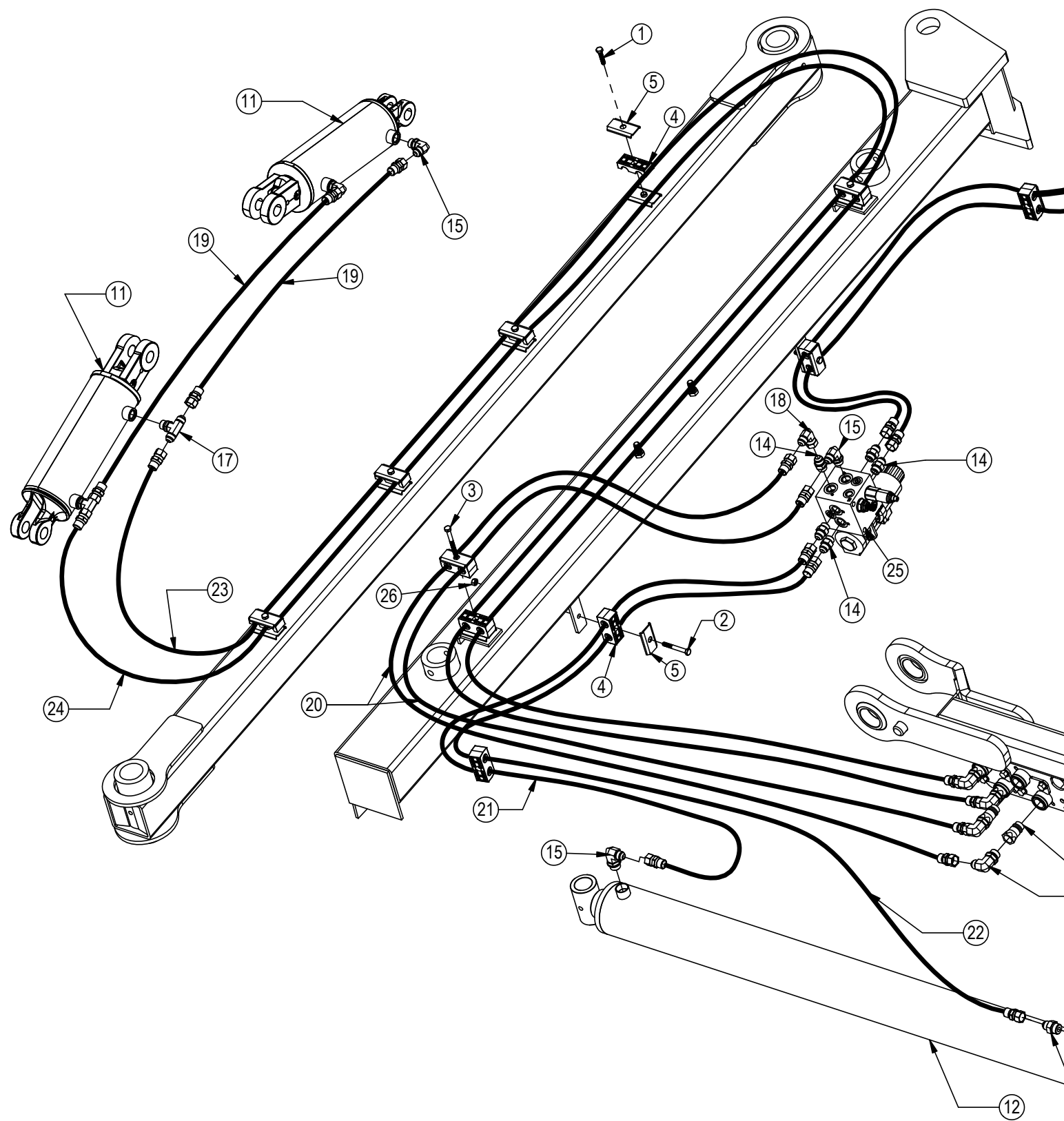

		Configuration	HAHT	HANT
Item No.	Part No.	Description	Qty.	Qty.
1	16-20036	5/16" x 1-1/2" Hex Bolt Gr 5 NC	7	3
2	16-20040	5/16" x 2-1/2" Hex Bolt Gr 5 NC	2	2
3	16-20043	5/16" x 3-1/4" Hex Bolt Gr 5 NC	1	-
4	18-3074	Hose Hold Down Clamp	9	5
5	18-3075	Hose Hold Down Clamp Plate	10	5
6	25-34342	Tappet Quick Coupler Male	4	2
7*	25-3453	Pioneer Dust Cap Tilt (Green)	2	-
8*	25-3454	Pioneer Dust Plug Tilt (Green)	2	-
9*	25-3455	Pioneer Dust Cap Angle (Red)	2	2
10*	25-3456	Pioneer Dust Plug Angle (Red)	2	2
11	26-34711	4 x 8 Cylinder W/ Cast Clevis Ends	2	-
12	26-34725	4 x 43.5 Cylinder Tube Ends, Top Port	2	2

\* Parts Not Shown

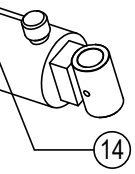
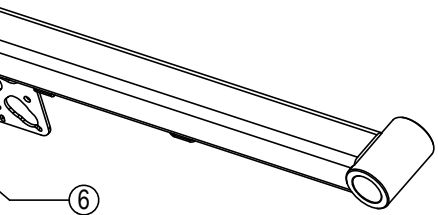
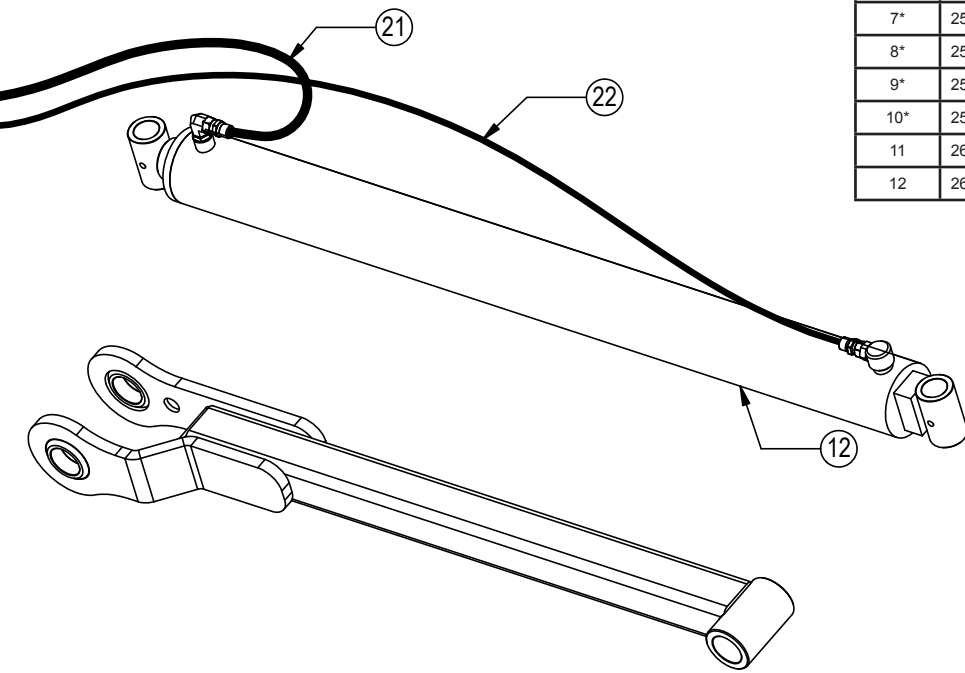

See Page 22 for the remaining hydraulics and hydraulic connections.  
See Page 26 for hydraulic schematics.

		Configuration	HAHT	HANT
Item No.	Part No.	Description	Qty.	Qty.
13*	31-13332	-6 SAE Breather Fitting	1	1
14	31-34040	Straight JIC x O-Ring (6400-8-8)	7	7
15	31-34050	Straight Thread Elbow 90° JIC x O-Ring (6801-8-8)	5	3
16	31-34051	Straight Thread Elbow 90° JIC x O-Ring (6801-8-10)	4	2
17	31-34060	Branch Tee JIC x O-Ring (6803-8-8-8)	2	-
18	31-34100	Swivel Nut Elbow 90° JIC (6500-8-8)	1	1
19	35-30022	39" x 3/8" -8JIC/-8JIC Hose	2	-
20	35-30131	66" x 1/2" -8JIC/-8JIC Hose (3.5M)	2	2
21	35-30132	69" x 1/2" -8JIC/-8JIC Hose	2	2
22	35-30141	96" x 1/2" -8JIC/-8JIC Hose	2	2
23	35-30071	217" x 3/8" -8JIC/-8JIC Hose	1	-
24	35-30075	207" x 3/8" -8JIC/-8JIC Hose	1	-
25	56-13305	Hydraulic Angle Valve	1	1
26	70-20581	5/16" Hex Nut NC	2	2

NOTE: When ordering cylinder seal kits, the part number on the cylinder is needed. The number is stamped on the base end of the cylinder opposite of the hydraulic ports.

No. On Cylinder	Part No.	Description
26-34711	49-12271	Seal Kit 4 x 8 (647135) Nitrided Rod, Clevis Ends
26-34725	49-12274	Seal Kit 4 x 43.5 (647210) Nitrided Rod

# Hydraulic Angle - 2 Lever System Hose Routing

Hoses Not Drawn To Scale

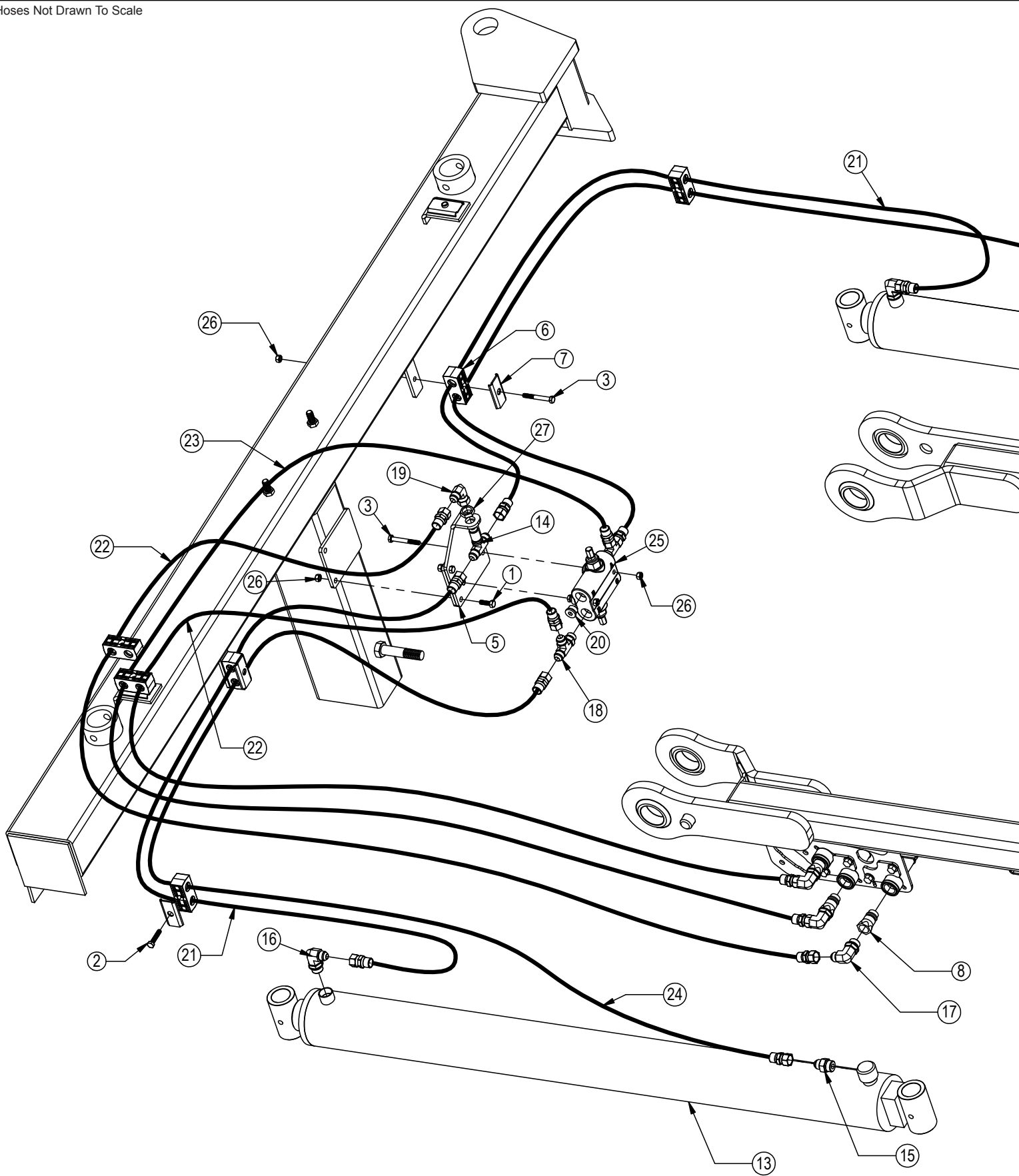

Item No.	Qty.	Part No.	Description
1	2	16-20034	5/16" x 1" Hex Bolt Gr 5 NC
2	2	16-20036	5/16" x 1-1/2" Hex Bolt Gr 5 NC
3	4	16-20040	5/16" x 2-1/2" Hex Bolt Gr 5 NC
4*	1	16-20048	5/16" x 5" Hex Bolt Gr 5 NC
5	1	18-14695	Bracket, Relief Valve
6	6	18-3074	Hose Hold Down Clamp
7	5	18-3075	Hose Hold Down Clamp Plate
8	3	25-34342	Tappet Quick Coupler Male
9*	1	25-3401	Pioneer Dust Cap Left Angle (Yellow)
10*	1	25-3402	Pioneer Dust Plug Left Angle (Yellow)
11*	2	25-3455	Pioneer Dust Cap Right Angle (Red)

\* Parts Not Shown

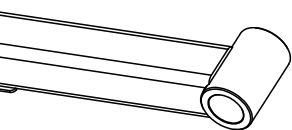
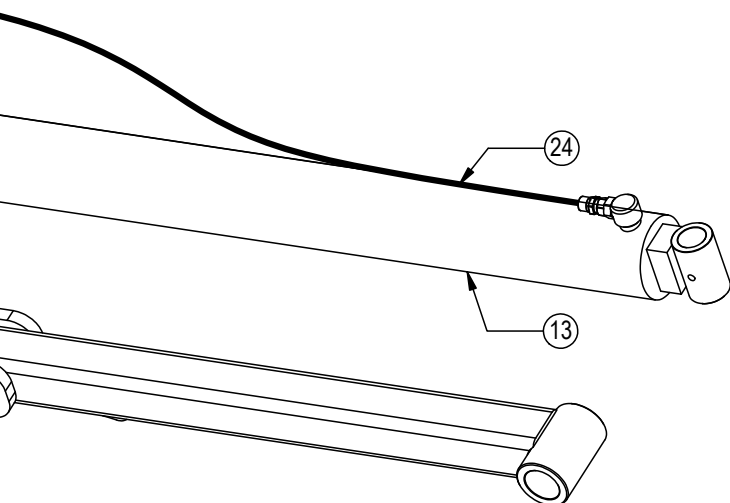

See Page 22 for the remaining hydraulics and hydraulic connections.  
See Page 27 for hydraulic schematics.

Item No.	Qty.	Part No.	Description
12*	2	25-3456	Pioneer Dust Plug Right Angle (Red)
13	2	26-34725	4 x 43.5 Cylinder Tube Ends, Top Port
14	1	31-34020	Bulkhead Branch Tee JIC (2703-8-8)
15	2	31-34040	Straight JIC x O-Ring (6400-8-8)
16	2	31-34050	Straight Thread Elbow 90° JIC x O-Ring (6801-8-8)
17	3	31-34051	Straight Thread Elbow 90° JIC x O-Ring (6801-8-10)
18	2	31-34070	Run Tee JIC x O-Ring (6804-8-8)
19	1	31-34100	Swivel Nut Elbow 90° JIC (6500-8-8)
20	2	31-34123	Hex Socket O-Ring Plug (6409-8-8)
21	2	35-30132	69" x 1/2" -8JIC/-8JIC Hose
22	2	35-30133	72" x 1/2" -8JIC/-8JIC Hose
23	1	35-30134	75" x 1/2" -8JIC/-8JIC Hose
24	2	35-30141	96" x 1/2" -8JIC/-8JIC Hose
25	1	56-7772	Relief Valve
26	6	70-20581	5/16" Hex Nut NC
27	1	70-20807	3/4" Hex Jam Nut NF

NOTE: When ordering cylinder seal kits, the part number on the cylinder is needed. The number is stamped on the base end of the cylinder opposite of the hydraulic ports.

No. On Cylinder	Part No.	Description
26-34725	49-12274	Seal Kit 4 x 43.5 (647210) Nitrided Rod

12-20 - NAHT Hydraulic Hose Routing

Item No.	Qty.	Part No.	Description
1	1	16-20125	1/2" X 1-1/4 " Hex Bolt Gr 5 NC
2	2	18-12991	Double Tube Clamp
3	1	18-19187-R	Tube Clamp Bracket - Right
4	4	25-34342	Tappet Quick Coupler Male - Poppet Style
5*	2	25-3403	Pioneer Dust Cap Slider (Blue)
6*	2	25-3405	Pioneer Dust Cap Slider (Brown)
7	2	26-34741	3 x 48 Welded Cylinder (647660)
8	4	31-34050	Straight Thread Elbow 90° JIC x O-Ring (6801-8-8)
9	4	31-34051	Straight Thread Elbow 90° JIC x O-Ring (6801-8-10)
10	1	35-11686-0670	67" x 3/8" -8JIC/-8JIC Hose

\* Parts Not Shown

Item No.	Qty.	Part No.	Description
11	1	35-11686-0820	82" x 3/8" -8JIC/-8JIC Hose
12	1	35-11686-1000	100" x 3/8" -8JIC/-8JIC Hose
13	1	35-11686-1390	139" x 3/8" -8JIC/-8JIC Hose
14	2	43-16306	Cylinder Pin
15	4	43-7767	Hitch Pin Clip
16*	4	43-18943	Cotter Pin
17	1	70-20604	1/2" Hex Center Lock Nut NC
18*	2	16-20125	1/2" X 1-1/4" Hex Bolt Gr 5 NC
19*	2	34-17585	12-20 Cylinder Strap
20*	2	70-20604	1/2" Hex Center Lock Nut NC

Hoses Not Drawn To Scale

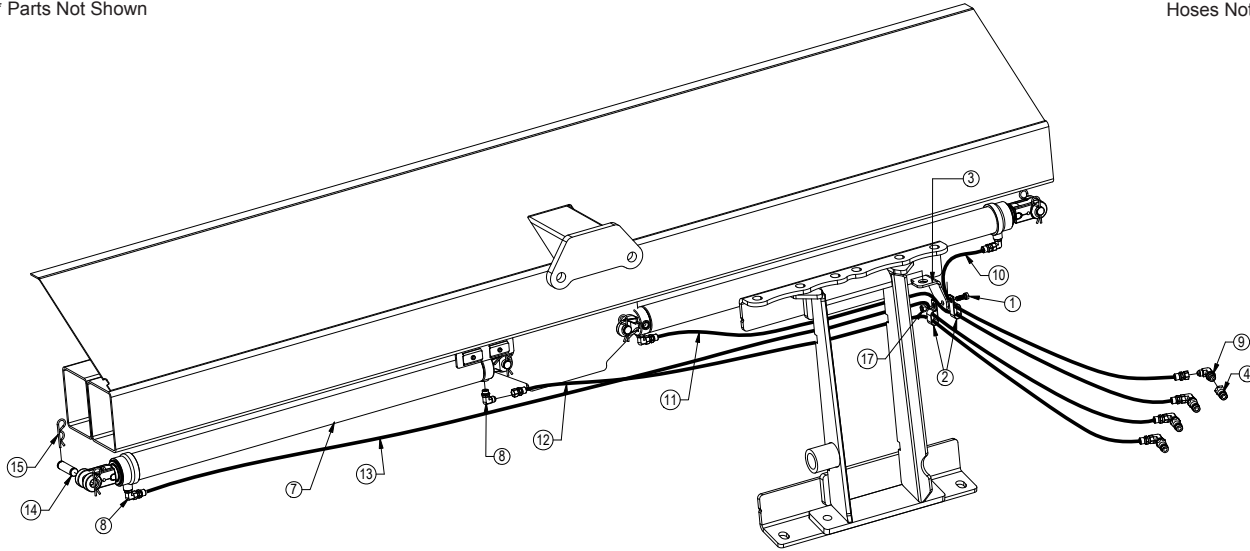

12-20 - NANT Hydraulic Hose Routing

Item No.	Qty.	Part No.	Description
1	1	16-20125	1/2" X 1-1/4 " Hex Bolt Gr 5 NC
2	2	18-12991	Double Tube Clamp
3	1	18-19187-R	Tube Clamp Bracket - Right
4	4	25-34342	Tappet Quick Coupler Male - Poppet Style
5*	2	25-3403	Pioneer Dust Cap Slider (Blue)
6*	2	25-3405	Pioneer Dust Cap Slider (Brown)
7	2	26-34741	3 x 48 Welded Cylinder (647660)
8	4	31-34050	Straight Thread Elbow 90° JIC x O-Ring (6801-8-8)
9	4	31-34051	Straight Thread Elbow 90° JIC x O-Ring (6801-8-10)
10	1	35-11686-0560	56" x 3/8" -8JIC/-8JIC Hose

\* Parts Not Shown

Item No.	Qty.	Part No.	Description
11	1	35-11686-0690	69" x 3/8" -8JIC/-8JIC Hose
12	1	35-11686-0850	85" x 3/8" -8JIC/-8JIC Hose
13	1	35-11686-1360	136" x 3/8" -8JIC/-8JIC Hose
14	2	43-16306	Cylinder Pin
15	4	43-7767	Hitch Pin Clip
16*	4	43-18943	Cotter Pin
17	1	70-20604	1/2" Hex Center Lock Nut NC
18*	2	16-20125	1/2" X 1-1/4" Hex Bolt Gr 5 NC
19*	2	34-17585	12-20 Cylinder Strap
20*	2	70-20604	1/2" Hex Center Lock Nut NC

Hoses Not Drawn To Scale

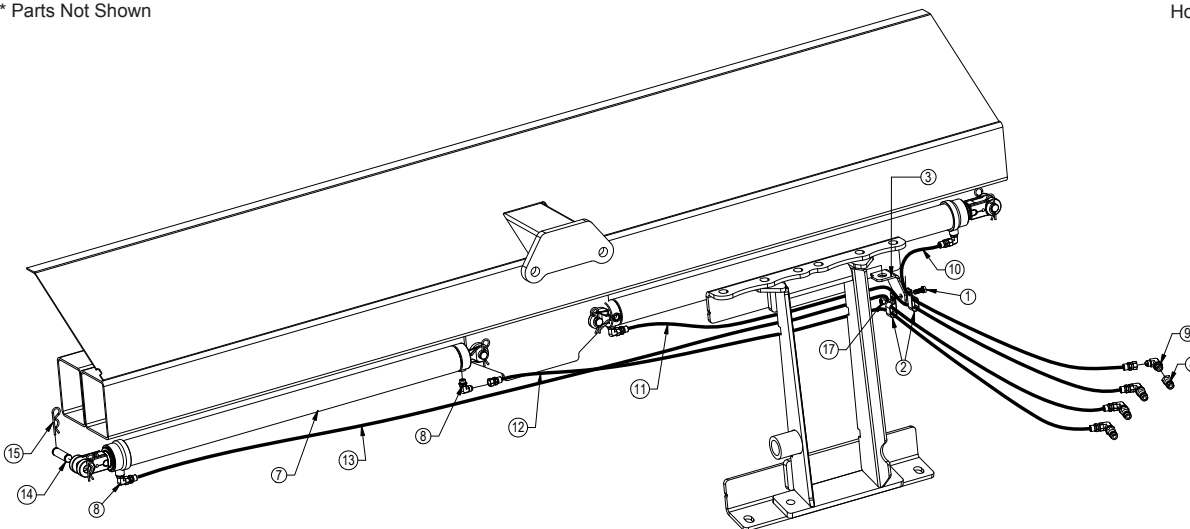



Item No.	Qty.	Part No.	Description
1	6	16-20036	5/16" X 1-1/2 " Hex Bolt Gr 5 NC
2	2	18-3074	Hose Hold Down Clamp
3	2	18-3075	Hose Hold Down Clamp Plate
4	5	18-15684	Hose Hold Down Clamp Plate
5	4	25-34342	Tappet Quick Coupler Male - Poppet Style
6*	2	25-3403	Pioneer Dust Cap Slider (Blue)
7*	2	25-3405	Pioneer Dust Cap Slider (Brown)
8	2	26-34741	3 x 48 Welded Cylinder (647660)
9	4	31-34050	Straight Thread Elbow 90° JIC x O-Ring (6801-8-8)
10	4	31-34051	Straight Thread Elbow 90° JIC x O-Ring (6801-8-10)
11	1	35-11686-1820	182" x 3/8" -8JIC/-8JIC Hose

Item No.	Qty.	Part No.	Description
12	1	35-11686-1980	198" x 3/8" -8JIC/-8JIC Hose
13	1	35-11686-2270	227" x 3/8" -8JIC/-8JIC Hose
14	1	35-11686-2560	256" x 3/8" -8JIC/-8JIC Hose
15	2	43-16306	Cylinder Pin
16	8	43-7767	Hitch Pin Clip
17*	2	16-20125	1/2" X 1-1/4" Hex Bolt Gr 5 NC
18*	2	34-17585	12-20 Cylinder Strap
19*	2	70-20604	1/2" Hex Center Lock Nut NC

Hoses Not Drawn To Scale

\* Parts Not Shown

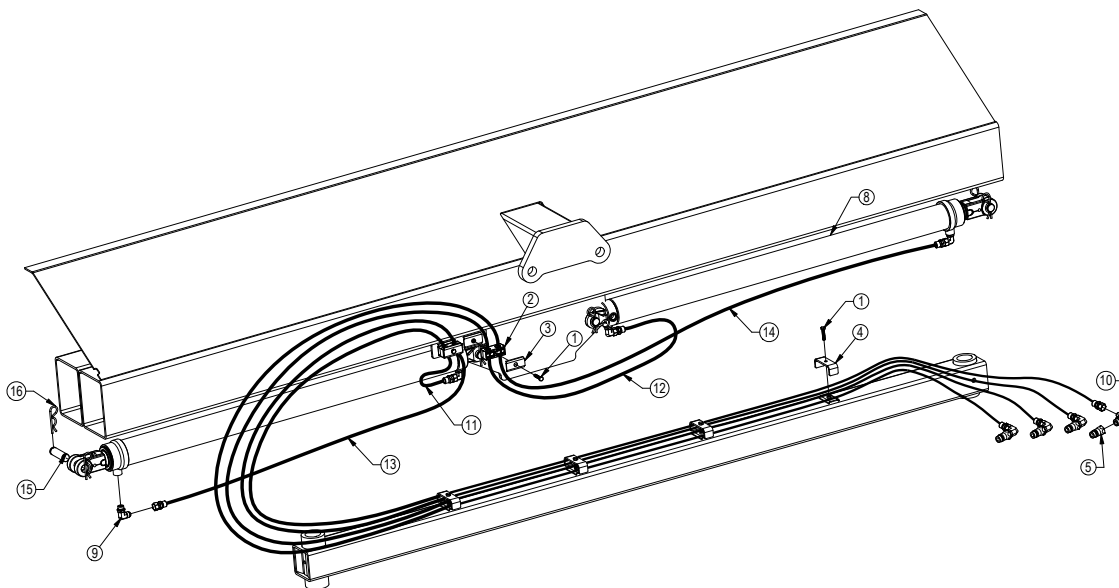

### 12-20 Blade Cylinders

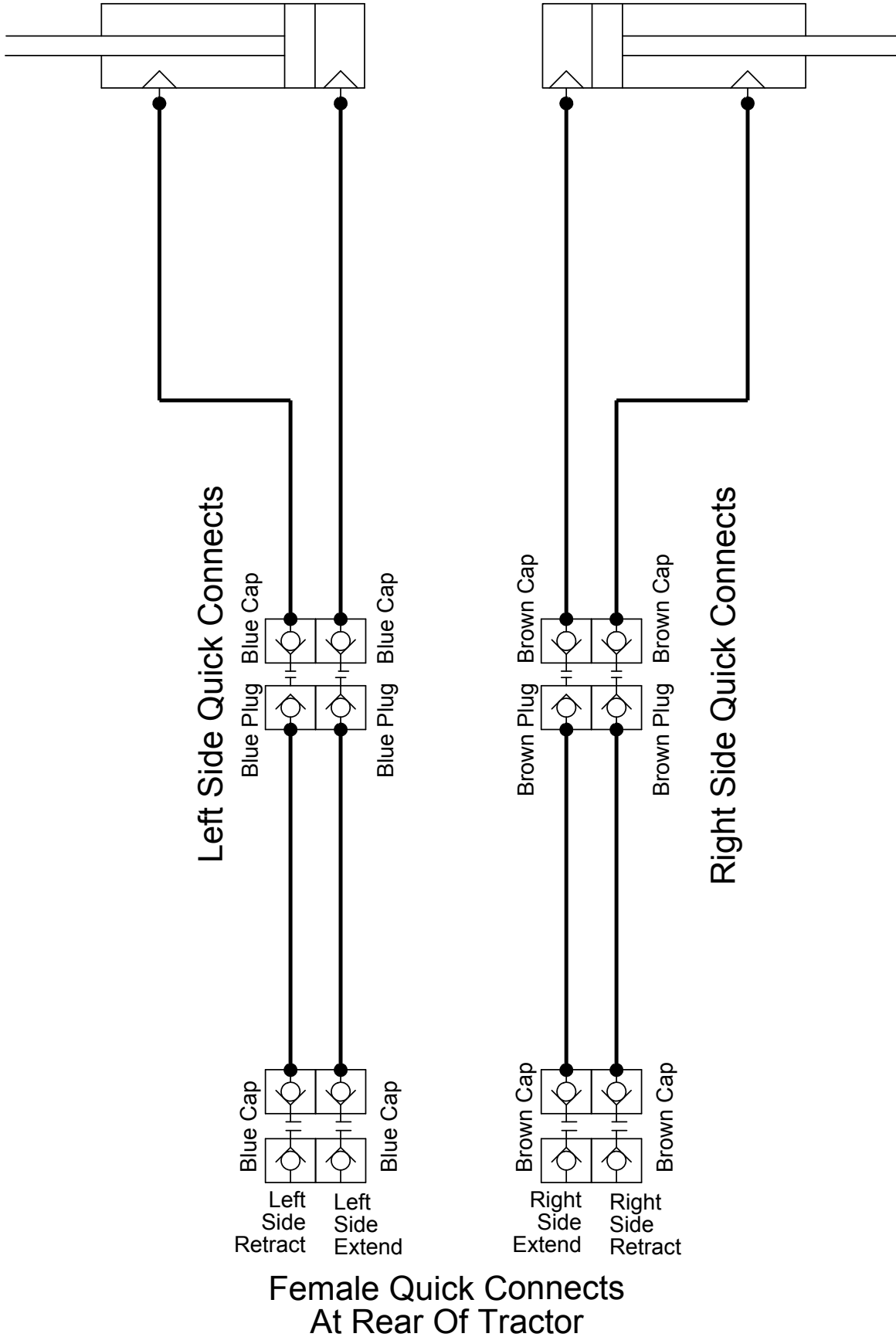

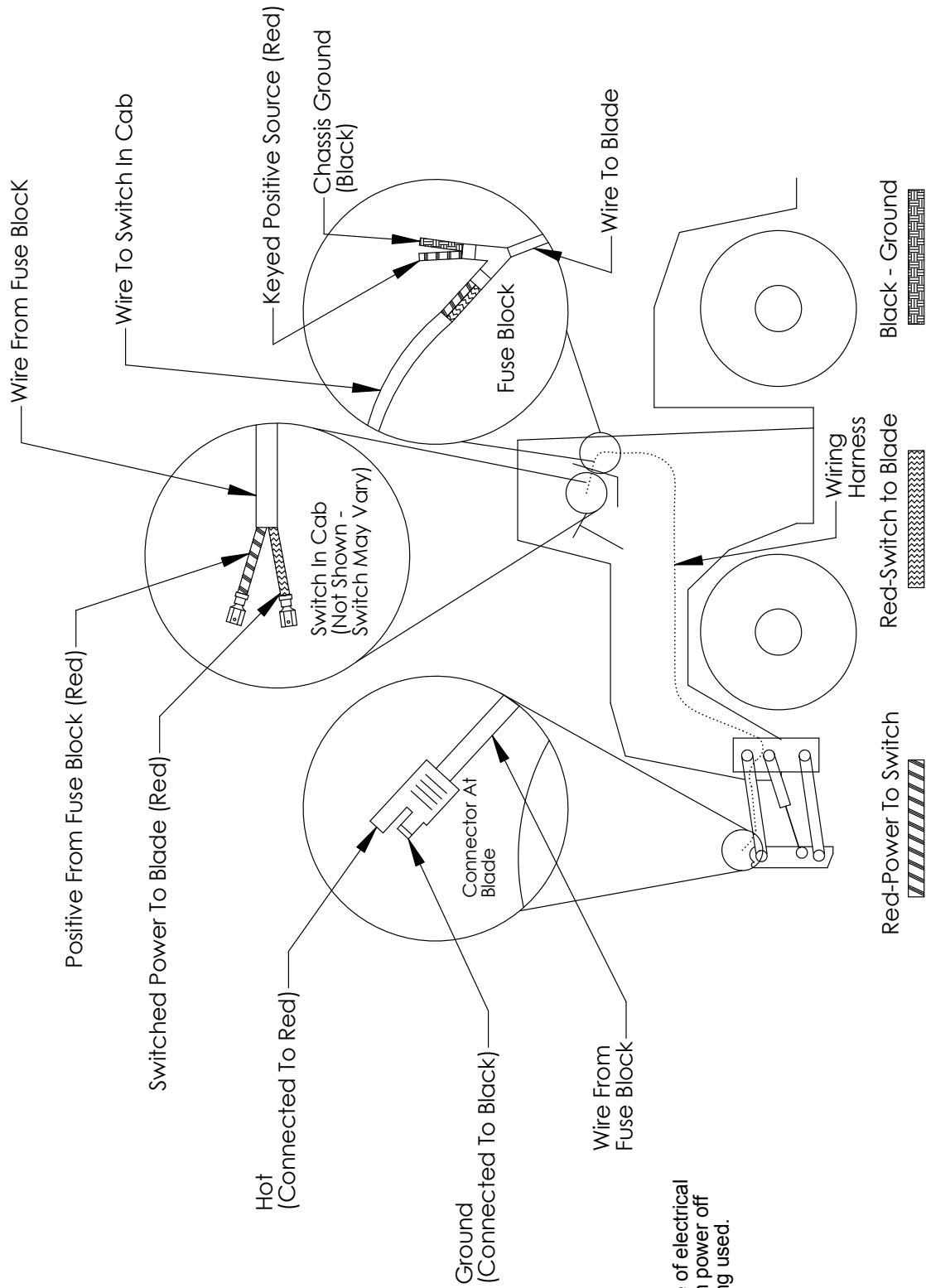

Note: To maximize life of electrical system and valve, turn power off when dozer is not being used.

**Instructions**

1. Locate "keyed and fused" 12 V power supply in cab of tractor.
2. Disconnect battery.
3. Connect the red wire to power and the black wire to ground.
4. Install switch in convenient place in cab.
5. Route wire harness from switch to the blade. (plug-in connector at blade)
6. Connect the switch to the wire harness.
7. Reconnect the battery.

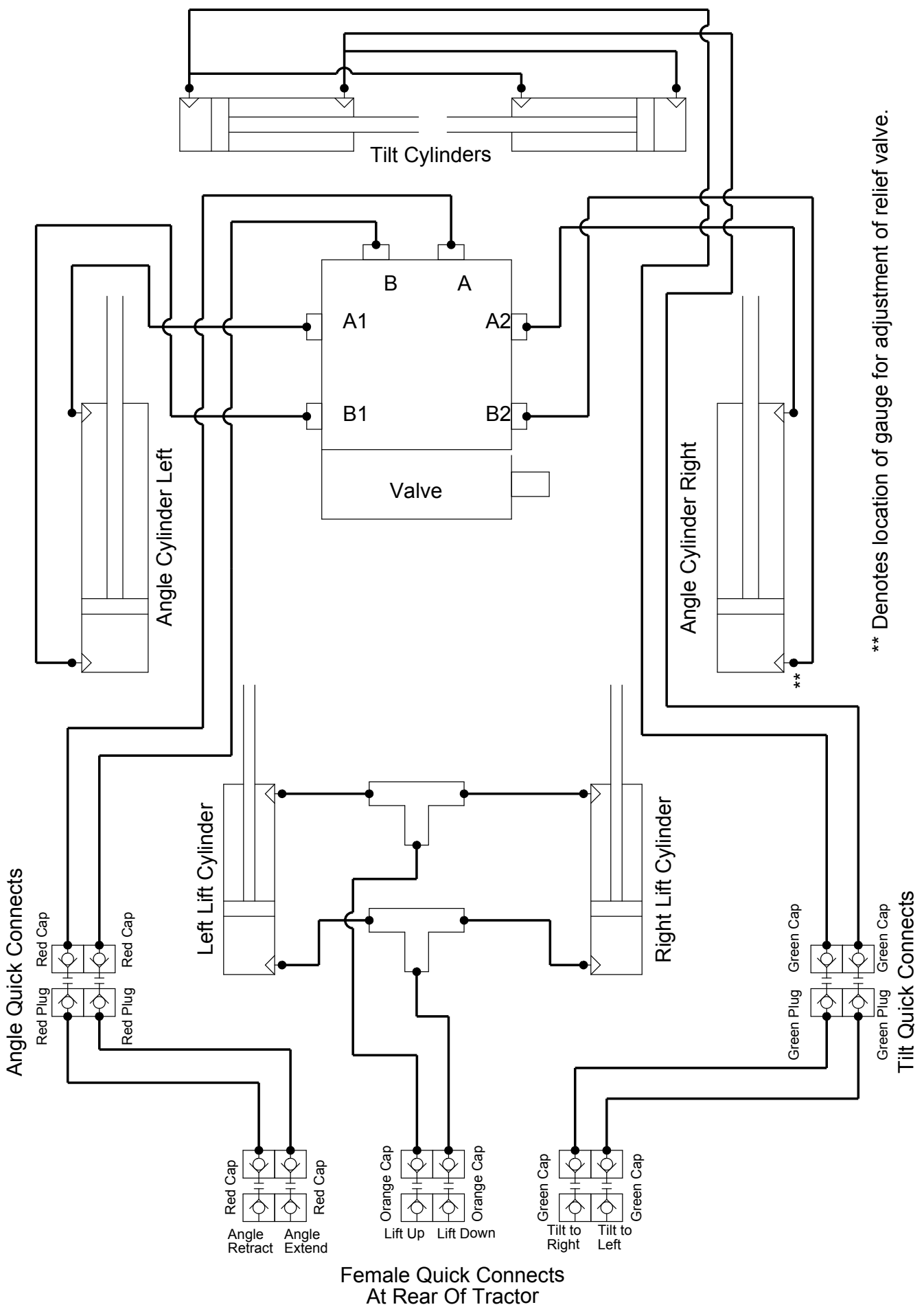

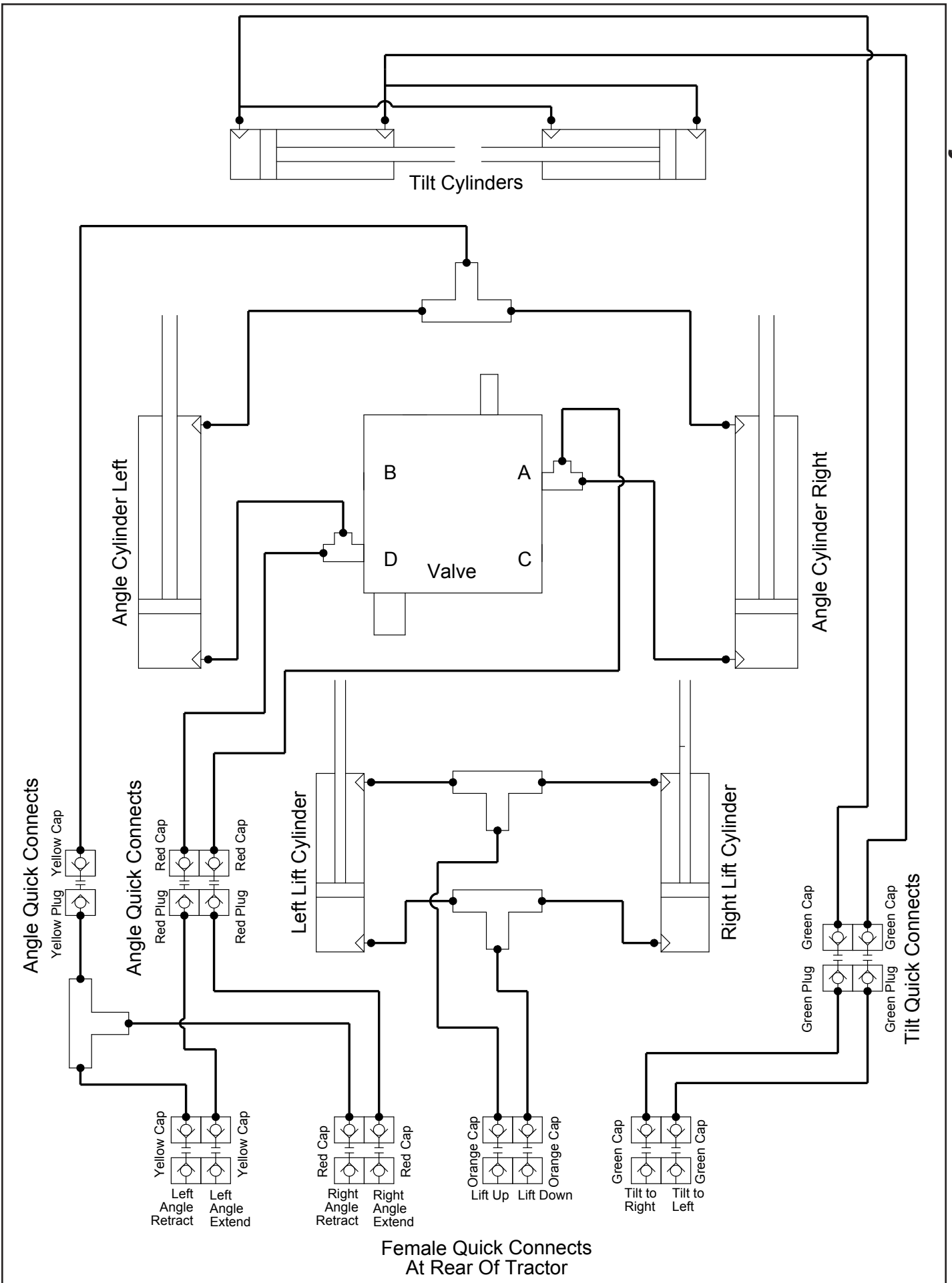

Pages Left Blank Intentionally

Pages Left Blank Intentionally

## Contact Us

---

---

As always, if you have any questions about your 12-20 Dozer or other products made by Grouser, feel free to contact us.

### **Grouser Products**

755 2nd Ave NW - West Fargo, ND 58078

**Phone:** 1-800-747-6182

**Fax:** 1-701-282-8131

**E-mail:** [grouser@grouser.com](mailto:grouser@grouser.com)

**Website:** [www.grouser.com](http://www.grouser.com)



## Improvements

---

---

Grouser Products Inc. is continually striving to improve its products. We reserve the right to change prices, specification, or equipment at any time without notice. We also reserve the right to make improvements or changes when it becomes practical and possible to do so without incurring any obligation to make changes or additions to the equipment sold previously.

## Warranty

---

---

Grouser Products warrants to the original purchaser of each item that the product be free from defects in material and workmanship under normal use and service for a period of two years from date of original retail delivery. If such equipment is found to be defective within two years, it is the obligation of Grouser Products under this warranty to repair or replace (exclusive of the cost of labor and transportation), any equipment or parts, in the judgment of Grouser Products to be defective in material or workmanship.

All equipment or parts claimed to be defective in material or workmanship must be made available for inspection at the place of business of a dealer authorized to handle the equipment covered by this warranty, or, upon request by Grouser Products, shipped to the Grouser Products factory in West Fargo, North Dakota. Grouser Products shall have no obligation to bear the cost of labor or transportation in connection with replacement or repair of any such defective parts in the setup process.

This warranty covers only defects in material and workmanship. It does not cover depreciation or damage caused by normal wear, accident, improper assembly, improper adjustments, improper maintenance including lack of proper lubrication, or improper use. Therefore, Grouser Products liability under this warranty shall not be effective or actionable unless the equipment is assembled, maintained and operated in accordance with the operating instructions accompanying the equipment. Grouser Products shall have no liability if the equipment has been altered or reworked without the written authorization of Grouser Products.

Grouser Products' parts, which are furnished under this warranty and properly installed, shall be warranted to the same extent as the original parts under this warranty if, and only if, such parts are found to be defective within the original warranty period covering the original equipment.

