



# Ag Pro Plus - Claas Xerion 4000 - 4500 - 5000 Undercarriage Installation Instructions

Purchase Date
Serial Number
Model Number
Tractor Model
Dealer

# Contents

Description	Page
To The Owner, Maintenance & Torque Specifications _____	2
Safety Precautions & Unpacking Components _____	3
Undercarriage Installation Instructions _____	4-9
Lift Components & Notes _____	10-11
Contact Us, Improvements, & Warranty _____	12

## To The Owner

This manual contains information concerning the operation, adjustment, and maintenance of the Ag Pro Plus dozer system. You have purchased dependable, long lasting equipment, but only by proper care and operation can you expect to receive the performance and long service built into our products. Please have all operators read this manual carefully and keep the manual available for ready reference. If you have any questions or concerns, contact Grouser Products.

## Maintenance

**Due to the harsh environment this equipment operates in, the following tasks should be performed every 10 hours or less.**

- Inspect all equipment before operation for existing or potential damages.
- Lubricate all joints with high quality grease.
- Inspect and tighten all bolts to torque specifications on page 3.
- Make sure all non-rotating pins are secured properly.
- Check hydraulic cylinders and hoses for damage or leaks. For replacement parts, see hydraulic pages for your specific system.

## Torque Specifications

All bolts should be tightened to the specifications that are stated. If specifications are not stated, follow torque charts below.

Size	Torque - Dry (ft-lbs)			
	SAE Grade 5		SAE Grade 8	
	UNC	UNF	UNC	UNF
5/16	19	20	29	31
3/8	33	36	47	51
7/16	54	58	78	85
1/2	78	85	119	129
9/16	114	124	169	184
5/8	154	167	230	250
3/4	257	280	380	414
7/8	382	416	600	654
1	587	639	903	984

Size	Torque - Dry (ft-lbs)
Grade 10.9	
M18 x 2.00	236
M20 x 2.50	432
M22 x 2.50	394
M24 x 3.00	570

# Safety Precautions

---

A careful operator is the best operator. Most accidents can be avoided by observing certain precautions. To help prevent accidents, read and take the following precautions before operating this equipment. In addition to these precautions, please follow all safety and operational instructions of your tractor manufacturer.

## **The Dozer:**

1. The Ag Pro Plus Dozer should be operated only by those who are responsible and instructed to do so.
2. Read the owner's manual carefully before using this equipment. Lack of operating knowledge can lead to accidents.
3. Keep the dozer maintained in reliable and satisfactory condition to ensure your safety.
4. Make sure the area is clear of people before moving any equipment.
5. Do not modify or permit anyone else to modify or alter the equipment and its components without first consulting Grouser Products.

## **Servicing the Dozer:**

1. Read and follow all safety instructions provided by the tractor manufacturer.
2. Always use proper personal safety gear when performing maintenance on equipment.
3. Before servicing, relieve hydraulic pressure, stop engine and fully engage parking brake.
4. Escaping hydraulic fluid under pressure can penetrate skin causing serious injury. If fluid is injected into skin, obtain medical attention immediately.
  - DO NOT use your hand to check for leaks. Use a piece of cardboard or paper to search for leaks.
  - Stop the engine and relieve pressure before connecting or disconnecting lines.
  - Tighten all connections before starting the engine or pressurizing lines.

## **Storing the Dozer:**

1. Thoroughly clean the dozer before storage. Use paint where necessary to prevent rust.
2. Check for worn or damaged parts. Install new parts as required.
3. Lubricate all pins and joints.

# Unpacking Components

---

Unstrap and remove any components that are attached for shipping. If any components are missing, call Grouser.

## Caution:

- Always use precaution when working around any equipment.
  - Always wear safety glasses.
  - Follow tractor manufacturer's safety guidelines when installing this product.
1. Read all instructions prior to performing installation.
  2. If applicable, remove the weights and the weight carrier from the front of the tractor.

**NOTE:** When installing hardware, only finger tighten until all hardware is in place.



3. Disconnect the wire harness from the lights in front of the front tires. Remove the carriage bolts (#1) and remove the bracket and lights from the tractor. They will be reinstalled to the undercarriage in a later step.

**NOTE:** The battery box can stay in place but reattach with 3/8" x 1-1/4" bolts and 3/8" Flange Nuts.

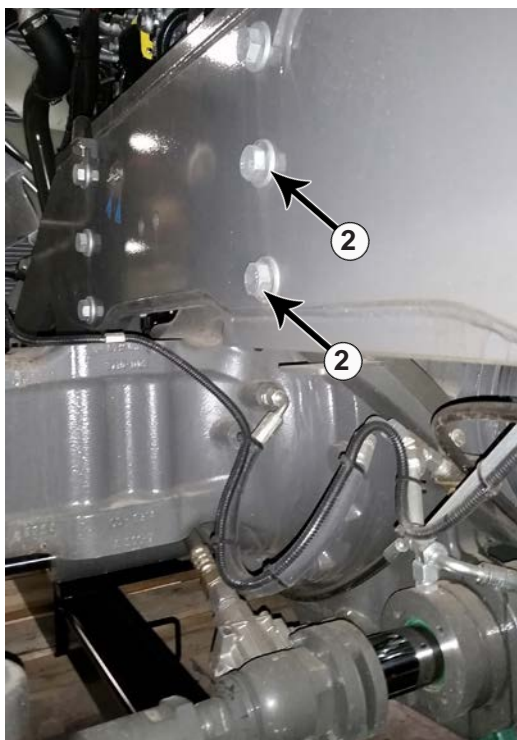

4. Behind the front axle, remove the bottom 2 bolts from each side of the tractor. You will reuse the washers from each bolt and the nuts from the bottom bolt on each side (#2)

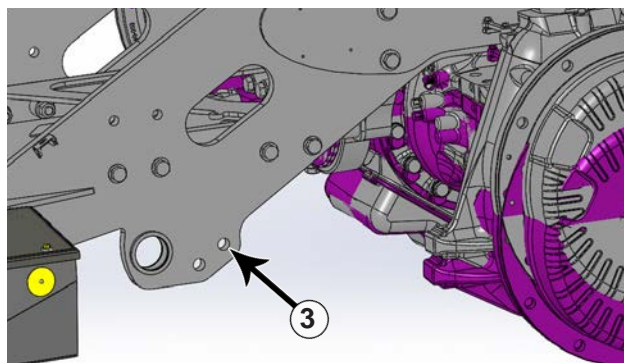

5. If applicable, remove 2 bolts in front of the front axle from each side of the tractor (#3).

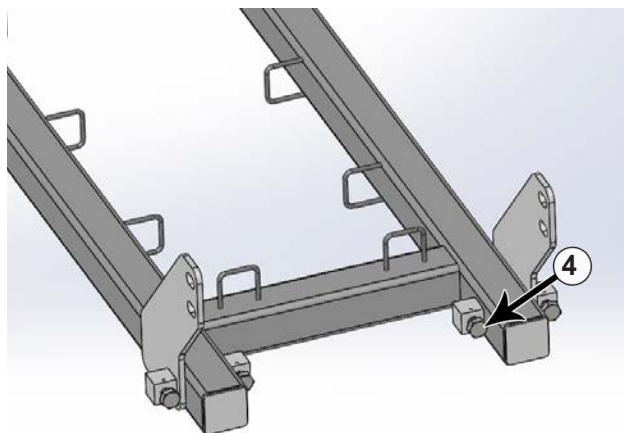

6. Install 4 - 1" x 3 bolts (PN: 16-20562) in the threaded boxes on the rear undercarriage weldment. The bolt heads need to be towards the back (#4). Turn the bolts all the way in for installation. The bolts will be adjusted in Step #28.

**NOTE:** A full diagram of the assembly with the full list of parts is on Page 8.

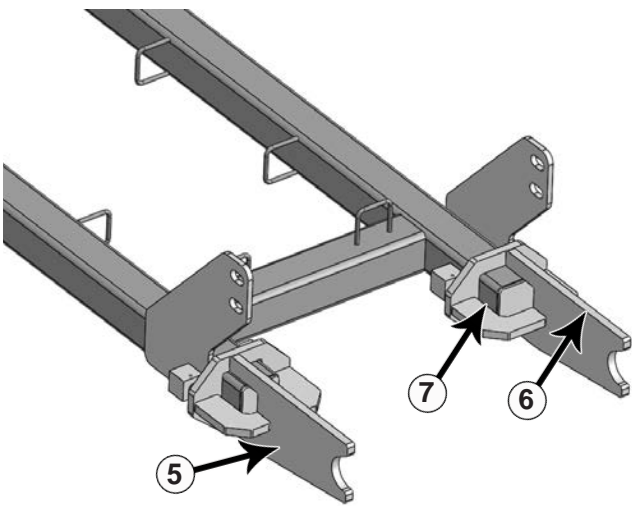

7. Put the rear brackets (PN: 18-17996-R,L) on the rear undercarriage weldment (PN: 54-17990) (#5). The orientation of the bracket should be as shown in the photo. The flat edge of the plate should be on top (#6) and the larger opening for the tube on the inside (#7).



8. In front of the rear axle, remove the front two bolts on each side (#8) as shown above. The washers will be reused in Step #12.

9. Position the rear undercarriage weldment under the tractor and center it with the frame of the tractor.

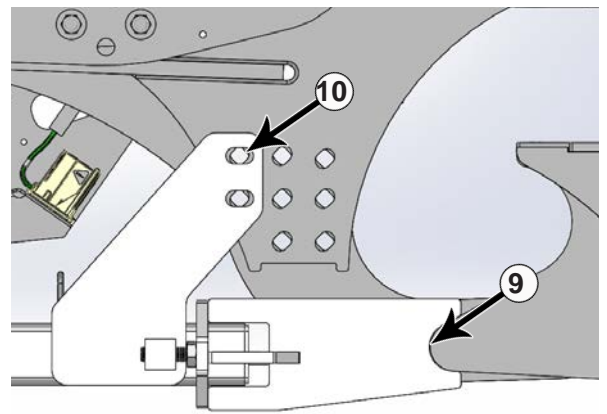

**NOTE:** Some parts are hidden for clarity.

10. Raise the rear undercarriage weldment up and guide the rear brackets between the tractor frame plates that you removed the bolts from in Step #8. The round part of the bracket will fit around the round part of the tractor frame plate (#9).

11. Line up the rear undercarriage weldment with the open tractor frame holes that you removed the bolts from in Step #8 (#10)



12. Attach the rear weldment to the tractor holes with 24mm x 100mm bolts (PN: 16-2486) and the washers that were removed in Step #8 and 24mm nuts (PN: 70-20874) (#11).



**13.** Behind the front axle, attach the side brackets to the tractor with 2 - 20mm x 110mm bolt (PN: 16-20150110) and a washer that was removed in Step #4 on each bolt. On the inside attach with a washer and nut that was removed in Step #4 on the bottom bolt on each side (#12).

**14.** Support the front end of the rear undercarriage until the front undercarriage is installed. You can temporarily attach the rear undercarriage to the side plates to hold it in place. The front undercarriage will also be attached to the side plates and the rear undercarriage in Step #18.

**15.** Position the undercarriage under tractor, center on the frame of the tractor. Lift undercarriage until holes in undercarriage line up with holes in the side of the tractor frame.

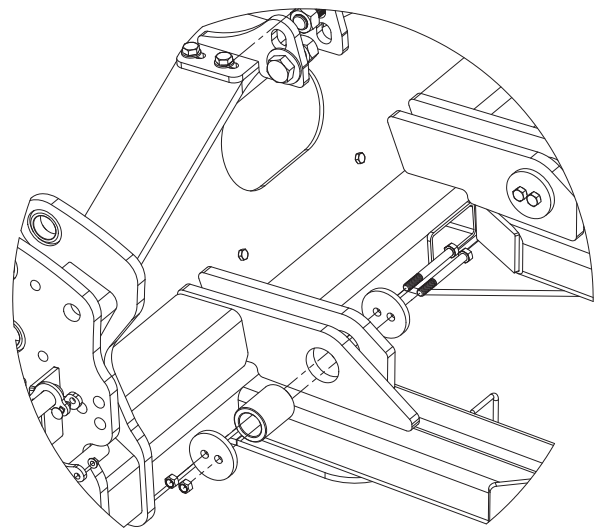

**16.** Insert the front pin (PN: 43-18531) into the front side of the undercarriage and into the frame of the tractor. The bolts will need to be inserted from the inside. Hold the pin in place by using 2 - 5/8" x 6" bolts (PN: 16-20200), 2 clamp plates (PN: 44-18003) and 2 - 5/8" nuts (PN: 70-20646) on each side.



**17.** In front of the front axle, insert a 7/8" x 3-1/2" bolt (PN: 16-20544) with a 7/8" heavy washer (PN: 57-3681) into each slot of the undercarriage and into the tractor frame on each side. Then on the inside attach with a 7/8" heavy washer (PN: 57-3681) and a 7/8" nut (PN: 70-20598) (#13).



**18.** Attach the side brackets to the front and the rear undercarriage weldments with 1" x 3" bolts (PN: 16-20562) and a 1" flat washer on each bolt (PN: 57-20749). Once all the bolts are through the holes, attach with a 1" flat washer and a 1" nut" (PN: 70-20599) on each bolt (#14).

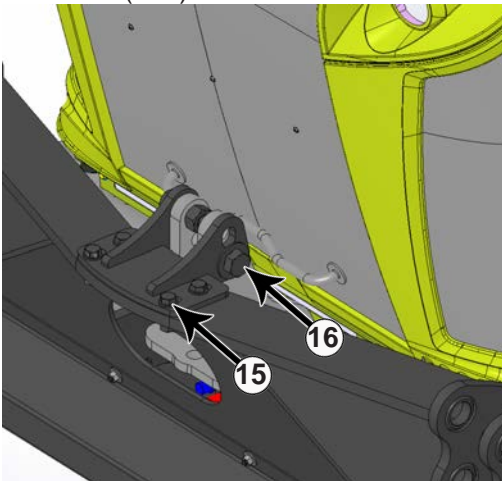

**19.** Attach the front top bracket to the front of the undercarriage with 4 - 3/4" x 2-1/2" bolts (PN: 16-20220), 8 - 3/4" hardened flat washers (PN: 57-20757) and 4 - 3/4" nuts (PN: 70-20607) (#15).

**20.** Attach the front top bracket to the tractor with a 1-1/4" x 3-1/2" bolt (PN: 16-20896) and a 1-1/4" flat washer (PN: 57-11671) on each side of the bracket. The bolts need to be staggered so one needs to go in the top and the other in the bottom. Finish by attaching with a 1-1/4" nut (PN: 70-20981) on each bolt (#16).

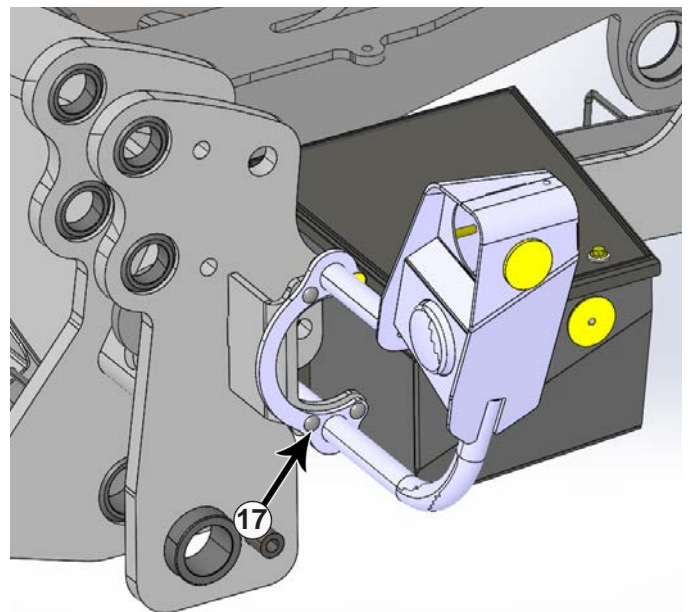

**21.** Attach the light brackets to the front of the undercarriage with 3 - 3/8" x 1-1/4" carriage bolts (PN: 16-21065) and a 3/8" flange nut (PN: 70-20622) on each bolt. Also use one of the original light bracket bolts, washer and nut (#17). Reconnect the light wire harness. Torque the 3/8" hardware to 33 ft-lbs.

**22.** Torque the 5/8" bolts from Step #16 to 154 ft-lbs.

**23.** Torque the 7/8" bolts from Step #17 to 600 ft-lbs.

**24.** Torque the 1" bolts from Step #18 to 903 ft-lbs.

**25.** Torque the 20mm bolts from Step #13 that bolt the side brackets to the side of the tractor frame to 470 ft-lbs.

**26.** Torque the 24mm bolts from Step #12 to 909 ft-lbs.

**27.** Torque the front nose bracket 1-1/4" bolts to 1,105 ft-lbs. and the 3/4" bolts to 380 ft-lbs.

**28.** Evenly unscrew the 1" bolts at the back of the undercarriage until they are tight up against the rear brackets and the rear bracket is pushing against the round plate in Step #10. Torque the 1" bolts to 200 ft-lbs.

**29.** Install a 5/16" x 3/4" bolt (PN: 16-20032) into each block at the rear of the undercarriage to hold the 1" x 3" bolt in place. Torque the 5/16" bolts to 19 ft-lbs.

**30.** After first 8 hours of use, re-torque all bolts. Check to make sure the 1" bolts at the back of the undercarriage are tight against the rear bracket as in Step #28.

**31.** Check all fasteners regularly to ensure proper operation of equipment.

THE INFORMATION CONTAINED IN THIS DRAWING IS THE SOLE PROPERTY OF GROUSER PRODUCTS INC ANY REPRODUCTION IN PART OR WHOLE WITHOUT THE WRITTEN PERMISSION OF GROUSER PRODUCTS INC IS PROHIBITED.

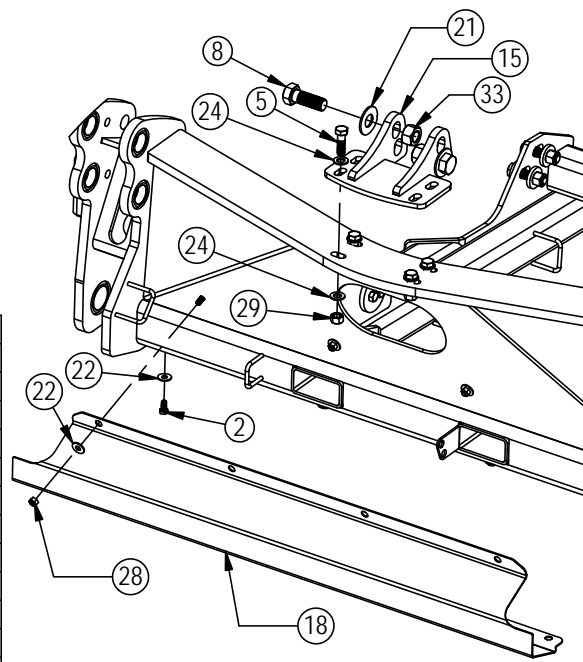
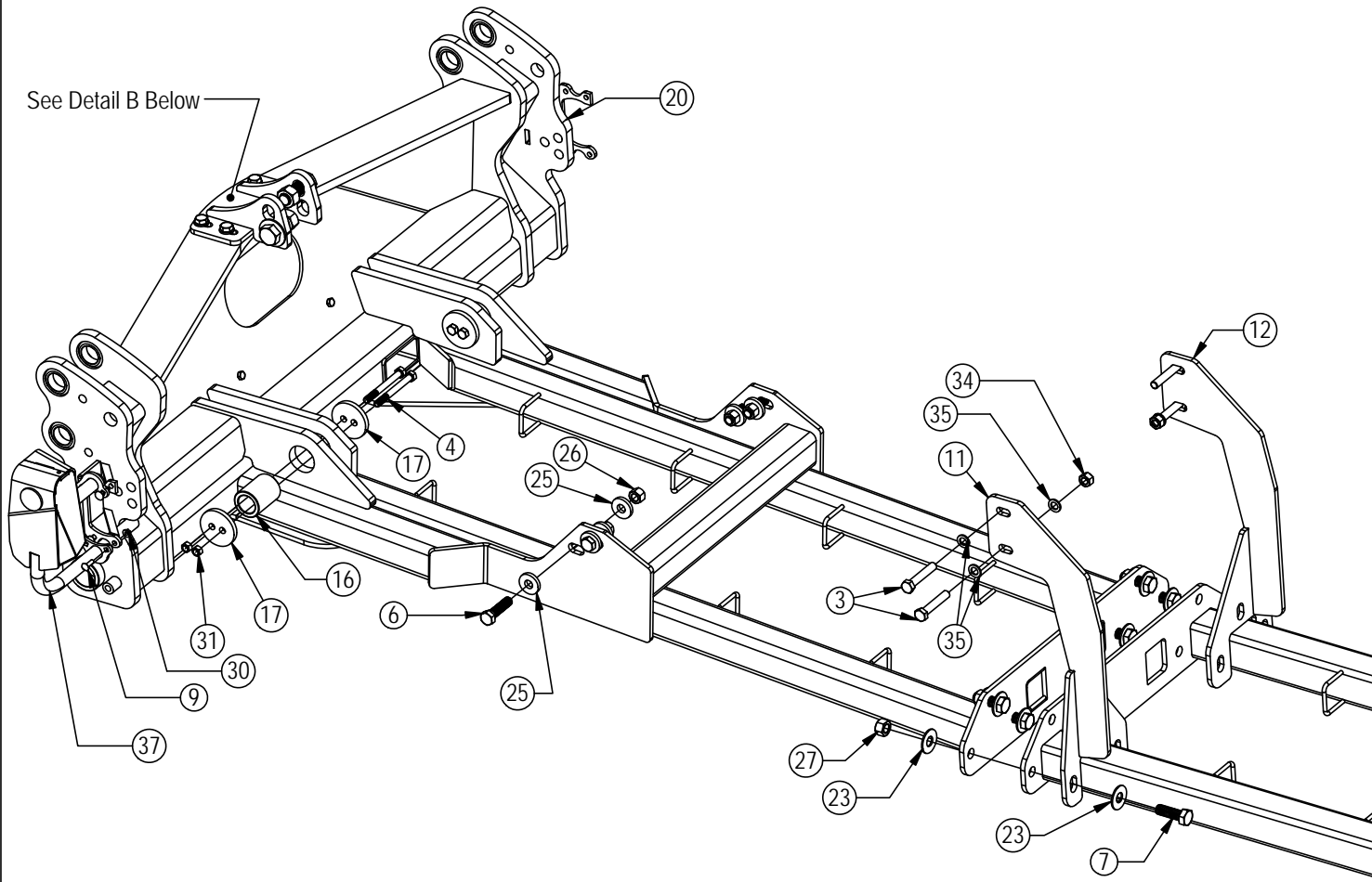

ITEM NO.	QTY.	PART NO.	DESCRIPTION
20	1	54-19070	Xerion UC Weld, Front
21	2	57-11671	1-1/4" Flat Washer
22	8	57-20744	1/2" Flat Washer
23	12	57-20749	1.00" Flat Washer-2.50" OD
24	8	57-20757	3/4" Flat Washer - 1-1/2" OD
25	8	57-3681	7/8" ID x 2-1/4" OD x .375" Heavy Washer CZ Plated
26	4	70-20598	7/8" Hex Nut Gr 8 NC
27	6	70-20599	1"-8 NC Hex Nut
28	4	70-20604	1/2" Center Lock Hex Nut
29	4	70-20607	3/4" Hex Center Lock Nut NC
30	6	70-20622	3/8" Flange Hex Nut Gr 5 NC
31	4	70-20646	5/8" Hex Top Lock Nut Gr 5 NC
32	4	70-20874	24mm Hex Nut 3.0 Pitch CL 8
33	2	70-20981	1-1/4" Hex Nut Gr 5 NC
34	2		20mm Hex Nut 2.5 Pitch- Use Original Tractor Nut
35	6		20mm Flat Washer - Use original tractor washer
36	8		24mm Flat Washer - Use original tractor washer
37	1		Light bracket original hardware



ITEM NO.	QTY.	PART NO.	DESCRIPTION
1	4	16-20032	5/16" x 3/4" Hex Bolt Gr 5 NC
2	4	16-20124	1/2" x 1" Hex Bolt Gr.5 NC
3	4	16-20150110	20mm x 1.50mm x 110mm Metric Hex Bolt Gr 10.9 Fine
4	4	16-20200	5/8" X 6" Hex Bolt Gr 5 NC
5	4	16-20220	3/4" x 2-1/2" Hex Bolt Gr.5 NC
6	4	16-20544	7/8" X 3-1/2" Hex Bolt Gr 8 NC
7	10	16-20562	1" x 3" Hex Bolt Gr.8 NC
8	2	16-20896	1-1/4" x 3-1/2" Hex Bolt Gr.5 NC
9	6	16-21065	3/8 x 1.25 Carriage Bolt Gr 5 NC
10	4	16-2486	24mm x 3.0mm x 90mm Hex Bolt
11	1	18-17995-L	Xerion Side Bracket
12	1	18-17995-R	Xerion Side Bracket
13	1	18-17996-L	Xerion Rear Bracket
14	1	18-17996-R	Xerion Rear Bracket
15	1	18-18549	Top Bracket
16	2	43-18531	Pin
17	4	44-18003	Plate, Clamp
18	1	44-18529R1	Claas Line Cover
19	1	54-17990R2	Xerion UC Weld, Rear

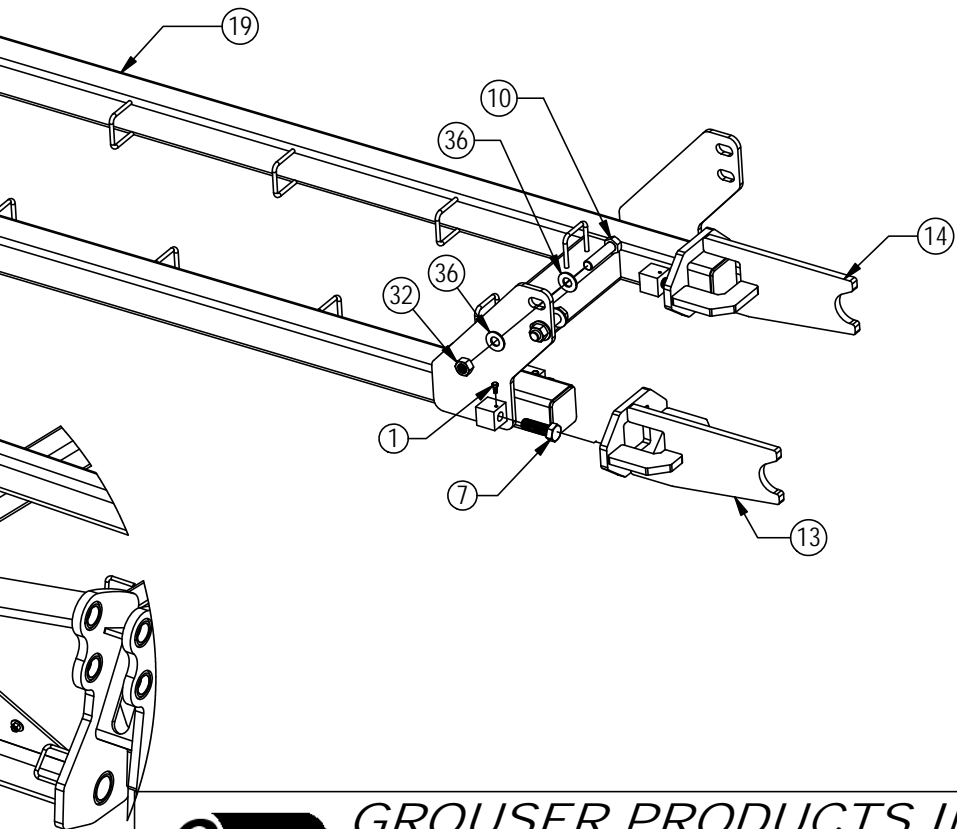

**GROUSER PRODUCTS INC.**

755 2nd Ave NW Phone 701.282.7710  
 West Fargo, ND 58078 Fax 701.282.8131  
 WWW.GROUSER.COM

DETAIL B  
 SCALE 1 : 24

TITLE: **Claas**

Date: 8/5/2015

DWG. NO.: 19070-A

# Assembling Lift Components

---

---

Refer to the Ag Pro Plus Owner's Manual & Parts Book for instructions on how to assemble the lift components.

# Notes

---

# Contact Us

---

As always, if you have any questions about your Ag Pro Plus Dozer or other products made by Grouser, feel free to contact us.

## **Grouser Products**

755 2nd Ave NW - West Fargo, ND 58078

**Phone:** 1-800-747-6182

**Fax:** 1-701-282-8131

**E-mail:** [grouser@grouser.com](mailto:grouser@grouser.com)

**Website:** [www.grouser.com](http://www.grouser.com)



# Improvements

---

Grouser Products Inc. is continually striving to improve its products. We reserve the right to change prices, specification, or equipment at any time without notice. We also reserve the right to make improvements or changes when it becomes practical and possible to do so without incurring any obligation to make changes or additions to the equipment sold previously.

# Warranty

---

Grouser Products warrants to the original purchaser of each item that the product be free from defects in material and workmanship under normal use and service for a period of two years from date of original retail delivery. If such equipment is found to be defective within two years, it is the obligation of Grouser Products under this warranty to repair or replace (exclusive of the cost of labor and transportation), any equipment or parts, in the judgment of Grouser Products to be defective in material or workmanship.

All equipment or parts claimed to be defective in material or workmanship must be made available for inspection at the place of business of a dealer authorized to handle the equipment covered by this warranty, or, upon request by Grouser Products, shipped to the Grouser Products factory in West Fargo, North Dakota. Grouser Products shall have no obligation to bear the cost of labor or transportation in connection with replacement or repair of any such defective parts in the setup process.

This warranty covers only defects in material and workmanship. It does not cover depreciation or damage caused by normal wear, accident, improper assembly, improper adjustments, improper maintenance including lack of proper lubrication, or improper use. Therefore, Grouser Products liability under this warranty shall not be effective or actionable unless the equipment is assembled, maintained and operated in accordance with the operating instructions accompanying the equipment. Grouser Products shall have no liability if the equipment has been altered or reworked without the written authorization of Grouser Products.

Grouser Products' parts, which are furnished under this warranty and properly installed, shall be warranted to the same extent as the original parts under this warranty if, and only if, such parts are found to be defective within the original warranty period covering the original equipment.

