



Ag Pro Plus/Ag Pro SS

JD 9R FT4 - DR Axle

Undercarriage Installation Instructions

Purchase Date
Serial Number
Model Number
Tractor Model
Dealer

Contents

Description	Page
To The Owner, Maintenance & Torque Specifications _____	2
Safety Precautions & Unpacking Components _____	3
Undercarriage Installation Instructions _____	4-10
Lift Components, Tow Cable Components & Notes _____	11
Contact Us, Improvements, & Warranty _____	12

To The Owner

This manual contains information concerning the operation, adjustment, and maintenance of the Ag Pro Plus dozer system. You have purchased dependable, long lasting equipment, but only by proper care and operation can you expect to receive the performance and long service built into our products. Please have all operators read this manual carefully and keep the manual available for ready reference. If you have any questions or concerns, contact Grouser Products.

Maintenance

Due to the harsh environment this equipment operates in, the following tasks should be performed every 10 hours or less.

- Inspect all equipment before operation for existing or potential damages.
- Lubricate all joints with high quality grease.
- Inspect and tighten all bolts to torque specifications on page 3.
- Make sure all non-rotating pins are secured properly.
- Check hydraulic cylinders and hoses for damage or leaks. For replacement parts, see hydraulic pages for your specific system.

Torque Specifications

All bolts should be tightened to the specifications that are stated. If specifications are not stated, follow torque charts below.

Size	Torque - Dry (ft-lbs)			
	SAE Grade 5		SAE Grade 8	
	UNC	UNF	UNC	UNF
5/16	19	20	29	31
3/8	33	36	47	51
7/16	54	58	78	85
1/2	78	85	119	129
9/16	114	124	169	184
5/8	154	167	230	250
3/4	257	280	380	414
7/8	382	416	600	654
1	587	639	903	984

Size	Torque - Dry (ft-lbs)
Grade 10.9	
M18 x 2.00	236
M20 x 2.50	432
M22 x 2.50	394
M24 x 3.00	570

Safety Precautions

A careful operator is the best operator. Most accidents can be avoided by observing certain precautions. To help prevent accidents, read and take the following precautions before operating this equipment. In addition to these precautions, please follow all safety and operational instructions supply by your tractor manufacturer.

The Dozer:

1. The Ag Pro Plus Dozer should be operated only by those who are responsible and instructed to do so.
2. Read the owner's manual carefully before using this equipment. Lack of operating knowledge can lead to accidents.
3. Keep the dozer maintained and in good condition to ensure your safety.
4. Make sure the area around you is clear of people before moving any equipment.
5. Do not modify or permit anyone else to modify or alter the equipment and its components without first consulting Grouser Products.

Servicing the Dozer:

1. Read and follow all safety instructions provided by the tractor manufacturer.
2. Always use proper personal safety gear when performing maintenance on equipment.
3. Before servicing, relieve hydraulic pressure, stop engine and fully engage parking brake.
4. Escaping hydraulic fluid under pressure can penetrate skin causing serious injury. If fluid is injected into skin, obtain medical attention immediately.
 - DO NOT use your hand to check for leaks. Use a piece of cardboard or paper to search for leaks.
 - Stop the engine and relieve trapped hydraulic pressure before connecting or disconnecting lines.
 - Tighten all connections before starting the engine or pressurizing lines.

Storing the Dozer:

1. Thoroughly clean the dozer before storage. Use paint where necessary to prevent rust.
2. Check for worn or damaged parts. Install new parts as required.
3. Lubricate all pins and joints.

Unpacking Components

Unstrap and remove any components that are attached for shipping. If any components are missing, call Grouser.

Caution:

- Always use caution when working around any equipment.
- Always wear safety glasses.
- Follow tractor manufacturer's safety guidelines when installing this product.

1. Read all instructions prior to performing installation.
2. If applicable, remove front weights, weight bracket and toolbox.
3. Remove cable holder behind the front axle if applicable. Keep spacer and washer to reinstall later.

NOTE: When installing hardware, only finger tighten until all hardware is in place.

NOTE: A full diagram of the assembly with the full list of parts is on Page 8.

NOTE: Refer to Page 10 to see a picture of the undercarriage assembly on the tractor if further clarification of location on the tractor is needed.

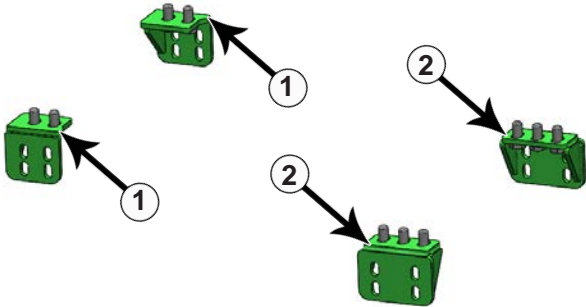

4. Remove the front 2 tractor axle frame bolts on each side and attach the front brackets to the front 2 holes on the tractor frame in front of the axle with a 24mm x 100mm bolt and a hardened washer in each hole (#1).

5. Remove the rear 3 tractor axle frame bolts on each side and attach each of the rear brackets to the 3 holes on the tractor frame behind the axle with a 24mm x 100mm bolt and a hardened washer in each hole (#2).

6. Push the brackets towards the center to make room for installing undercarriage.

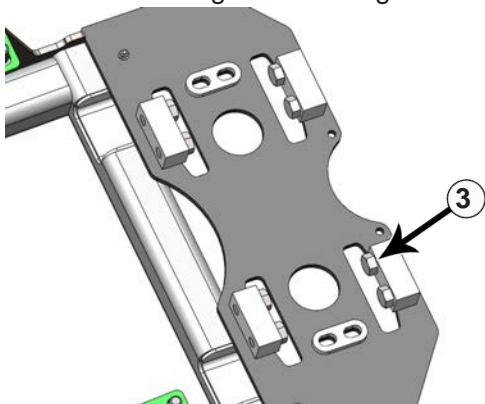

7. Completely thread 8 - 1" x 2" adjustment bolts (#3) at rear of undercarriage with heads facing towards each other. The bolts will be adjusted after the undercarriage is installed.

8. Position undercarriage under tractor, center on the frame of the tractor. Lift U/C until holes of U/C line up with holes in the side of the tractor frame.

NOTE: Add shims between the U/C and the tractor frame to reduce any gap if necessary. Use shims until there is a gap of 1/16" or less on the front. See attached diagram for the proper location and orientation of each shim. Don't put all the shims on one side of the undercarriage.

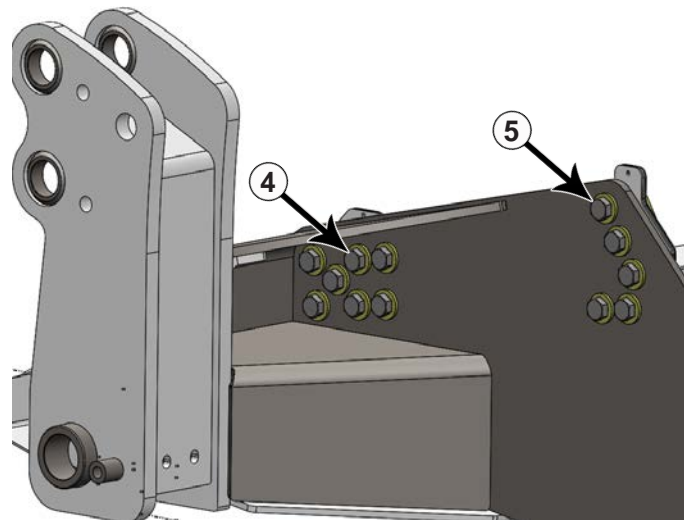

NOTE: Follow Steps #9-12 for the left side. After Step #12, tighten the bolts until they are snug. If necessary, add more shims on right side until a gap of 1/16" or less is on the right side. Proceed with Step #9-12 for the right side.

9. Install 7 - 3/4" x 3" bolts with a hardened flat washer (#4) through the front holes on each side of the U/C, shims if necessary, and the tractor frame.

10. Thread each bolt into the front threaded plate. See full assembly diagram on Page 8 for correct orientation of the plate. The side with the notch should be towards the front.

11. Install 5 - 3/4" X 3" bolts with a hardened flat washer (#5) through the slots on each side of the U/C, any shims if necessary, and the tractor frame.

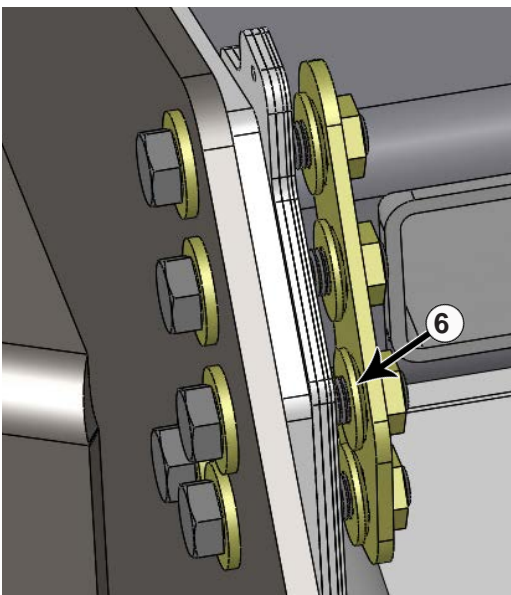

12. Thread a 3/4" flange nut on 4 of the top bolts from Step #11. Attach the nut plate to the bottom bolt and line up the top hex nuts to fit in the nut plate (#6). Note the orientation of the flange nuts.

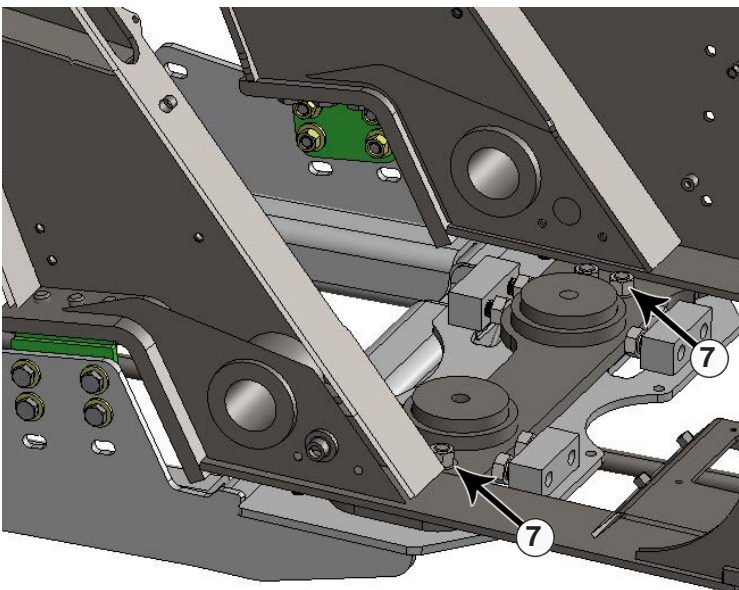

13. Attach the rear of the undercarriage vertically to the cross member on the tractor frame behind the rear axle with 4 - 7/8" x 3" bolts, 8 - 7/8" hardened flat washers, and 4 - 7/8" nuts (#7).

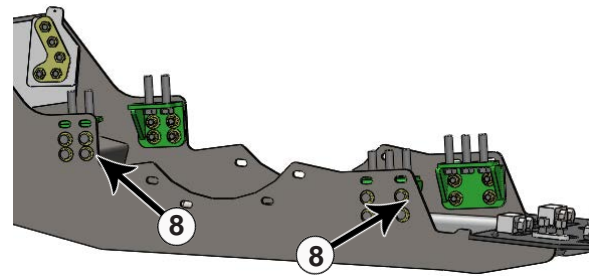

14. Attach the front and rear brackets (#8) to the inside of the undercarriage with a 3/4" x 2-1/4" bolt, 2 - hardened flat washers, and a 3/4" nut on each bolt.

15. Torque the rear vertical 7/8" bolts to 600 ft-lbs.

16. Torque the front 12 - 3/4" bolts on each side of the undercarriage to 380 ft-lbs.

17. Torque all of the 3/4" bolts attaching the brackets to the undercarriage to 380 ft-lbs. Alternate between the groups of bolts when torquing. For example, torque the front left bracket bolts, the rear right bracket bolts, rear left bracket bolts, front right bracket bolts.

18. Torque the vertical 24mm bolts to 909 ft-lbs.

NOTE: If available, John Deere service tool JDG650 (shown below) can be used to torque the vertical 24mm bolts.

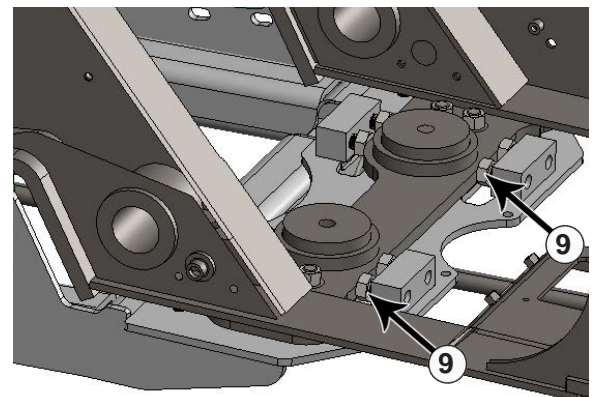

19. Unscrew the 1" x 2" bolts (#9) at the rear of the undercarriage until they are tight against the tractor frame. Torque the 1" bolts to 200 ft-lbs.

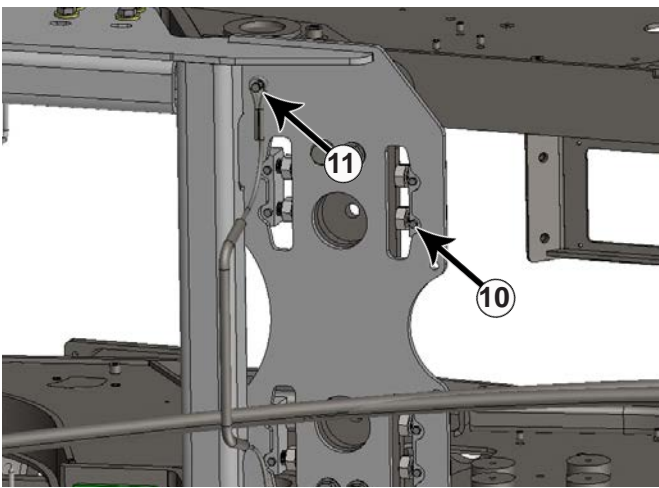

NOTE: View is from underneath the tractor and undercarriage.

20. Install a 5/16" x 3/4" bolts (#10) into the blocks at the rear of the undercarriage to lock each 1" x 2" bolt in place. Torque the 5/16" bolts to 19 ft-lbs.

21. If applicable, reinstall the cable holder with the original spacers and washers and use the supplied 3/8" x 1-3/4" bolts, 3/8" washers and 3/8" flange nuts at the rear of the undercarriage (#11). Torque the bolts to 47 ft-lbs.

NOTE: Original spacers and washers are not shown in the picture in Step #20 & 21.

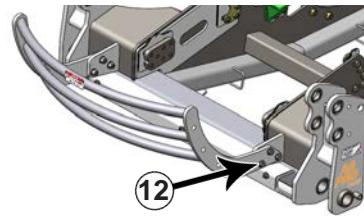

22. Install the grill guard to the front of the undercarriage with 3 - 3/4" x 2-1/2" bolts, 6 - 3/4" flat washers and 3 - 3/4" nuts on each side (12).

23. Torque the 3/4" bolts to 257 ft-lbs.

NOTE: If applicable, refer to Page 11 to attach the front of the tow cable.



24. At the pivot area of the tractor, remove the bolts from the top plate that hold the cylinder pins and install the hose routing bracket along with the original plate and new 12mm flange bolts. Torque the 12mm bolts to the same specification that the tractor manufacturer recommends (#13).

25. After first 8 hours of use, re-torque all bolts.

26. Check all fasteners regularly to ensure proper operation of equipment.

Hose Routing

1. Route hoses through the hose loops on the undercarriage until you reach the end of the undercarriage as shown below.



2. Route the hoses toward the center and attach to the undercarriage with a heavy zip tie (#14).

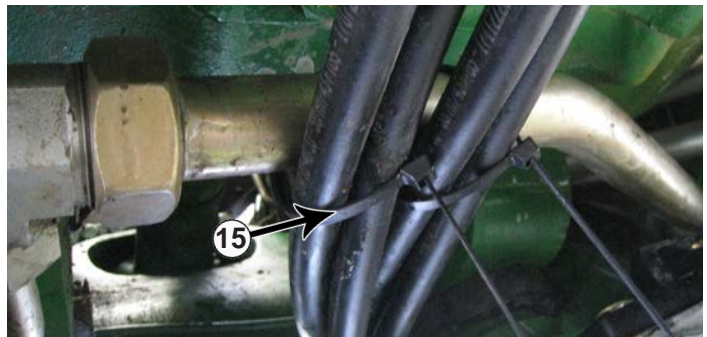

3. Right behind the cross member plate there is a steel line. Zip tie the hoses to this steel line (#15).

4. Route hoses up through the hose loops on the bracket that was installed in Step #24.

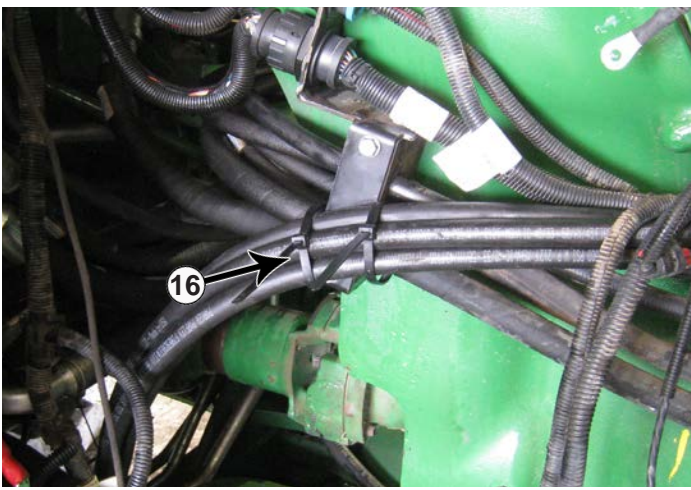

5. Route the hoses upward through the tractor. Staying away from the driveshaft by attaching the hoses to any other steel lines along the way. Attach to the tractor's hoses right by the hose bracket with zip ties (#16).



6. Continue the hoses through the open cavity of the back section of the tractor. Attach hoses where necessary to avoid rubbing and pinch areas. Plug the hoses into the open SCV's at the back of the tractor.

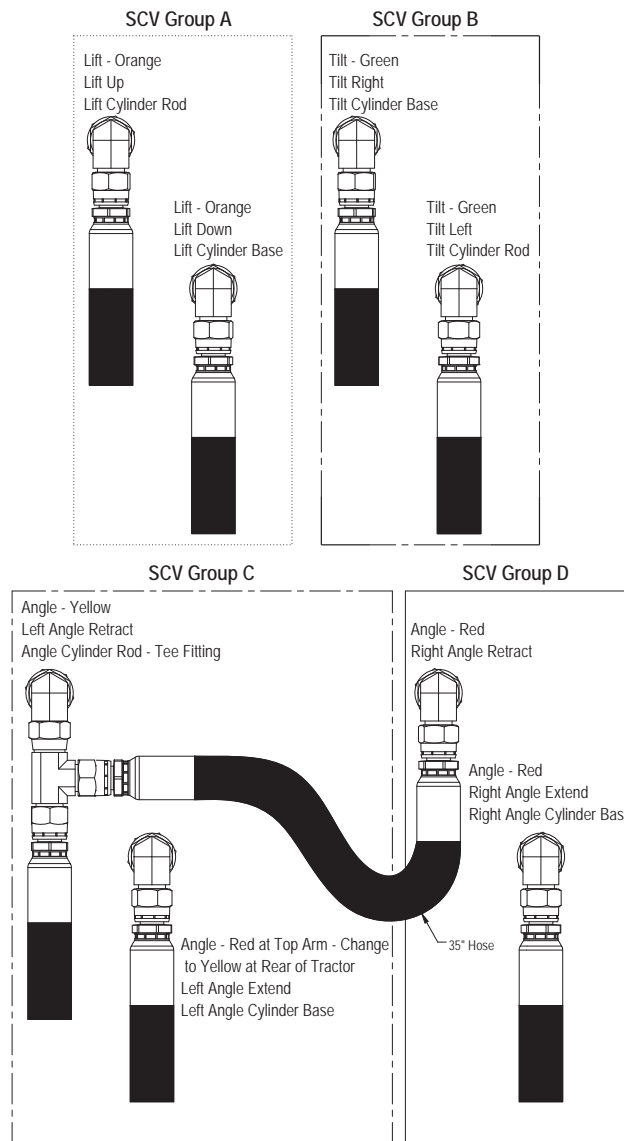

Hoses Not Drawn To Scale

NOTE: The quantity of hoses may vary depending on blade system.

NOTE: If blade system has Dual Remote Hydraulic Angle, verify that the 35" hose is used and installed correctly. Refer to hydraulic schematic in the Owner's Manual & Parts Book if necessary.

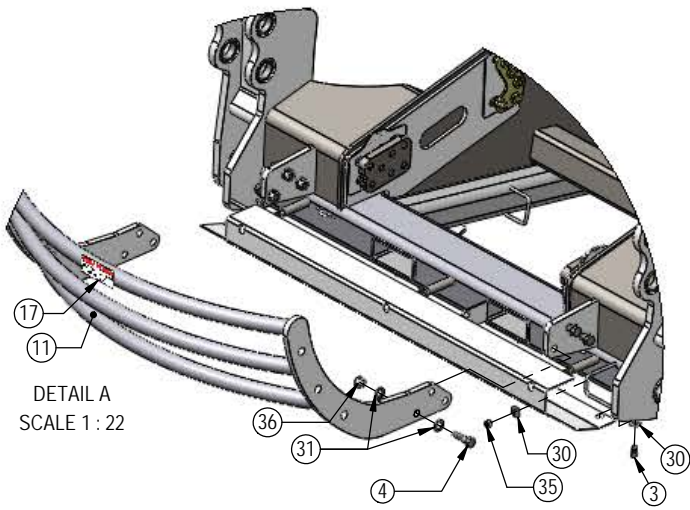

DETAIL A
SCALE 1 : 22

See Detail A
For Front View.

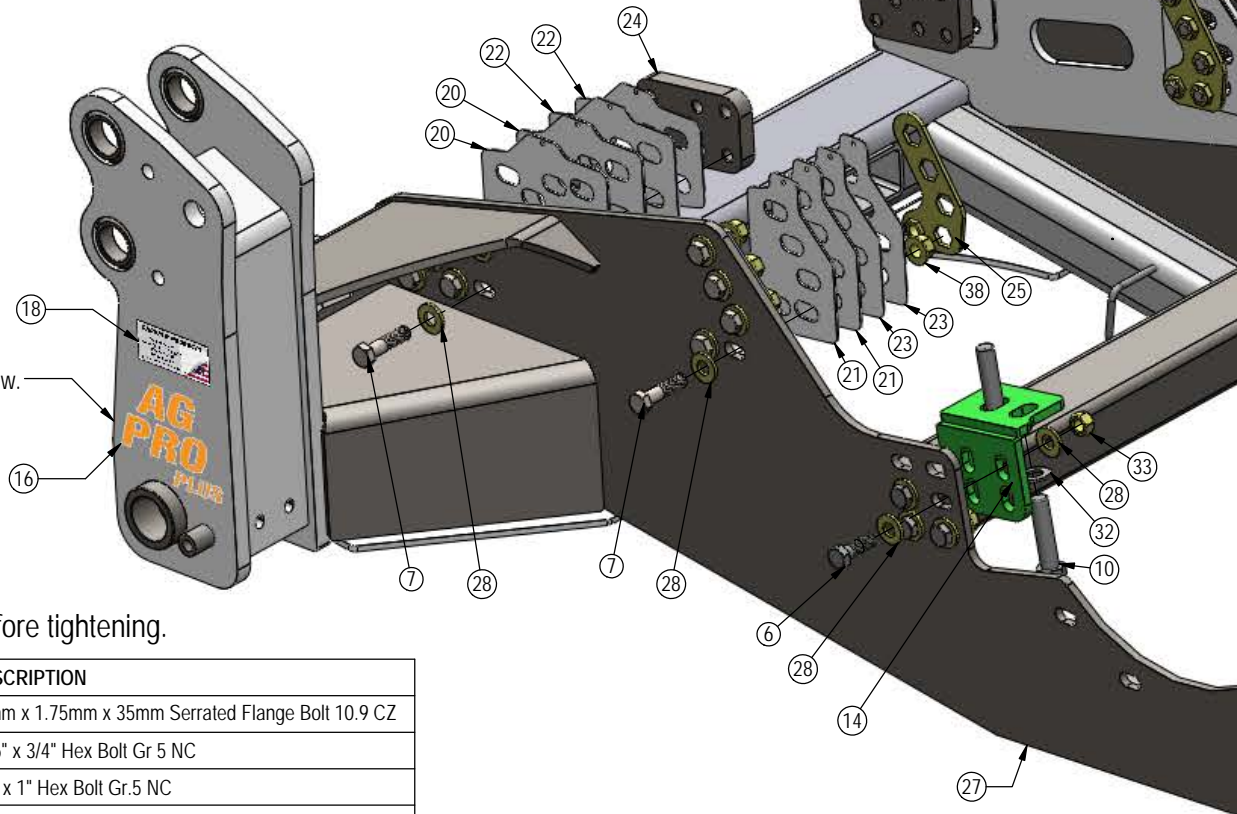

Note: Install all bolts before tightening.

ITEM NO.	QTY.	PART NO.	DESCRIPTION
1	4	16-18879	12mm x 1.75mm x 35mm Serrated Flange Bolt 10.9 CZ
2	8	16-20032	5/16" x 3/4" Hex Bolt Gr 5 NC
3	4	16-20124	1/2" x 1" Hex Bolt Gr.5 NC
4	6	16-20220	3/4" x 2-1/2" Hex Bolt Gr 5 NC
5	2	16-20357	3/8" X 1-3/4" Hex Cap Screw Gr 8 NC
6	16	16-20509	3/4" X 2-1/4" Hex Bolt Gr.8 NC
7	24	16-20512	3/4" X 3" Hex Bolt Gr 8 NC
8	4	16-20542	7/8" X 3" Hex Bolt Gr 8 NC
9	8	16-20558	1" x 2" Hex Bolt Gr. 8 NC
10	10	16-2486	24mm x 3.0mm x 90mm Hex Bolt
11	1	18-18059R2	Grill Guard Weld
12	1	18-18415R1	Bracket
13	2	18-19104	Rear Bracket Weld
14	1	18-19108-L	Front Bracket, Left
15	1	18-19108-R	Front Bracket, Right
16	2	27-18880	Ag Pro Plus Decal
17	1	27-18882	Not For Pushing or Pulling Decal

ITEM NO.	QTY.	PART NO.	DESCRIPTION
18	1	27-18887	Grouser Name Plate Decal
19	1	27-9506	Serial Tag Decal
20	3	44-18141	Shim, Front 1/8"
21	3	44-18142	Shim, Rear 1/8"
22	3	44-18143	Shim, Front 1/16"
23	3	44-18144	Shim, Rear 1/16"
24	2	44-18147	Plate, Front Nut
25	2	44-18245	Rear Nut Plate Weldment
26	1	44-19486	Plate, Cover
27	1	54-19600	Undercarriage Weld
28	56	57-19088	1.6875" OD x .813" ID x .187" HD Washer YZ
29	2	57-20742	3/8 Flat Washer
30	7	57-20744	1/2" Flat Washer
31	12	57-20757	3/4" Flat Washer - 1-1/2" OD
32	18	57-20758	7/8" SAE Hardened Flat Washer - 1-3/4" OD
33	16	70-20597	3/4" Hex Nut Gr.8 NC
34	4	70-20598	7/8" Hex Nut Gr 8 NC
35	3	70-20604	1/2" Center Lock Hex Nut
36	6	70-20607	3/4" Hex Center Lock Nut NC
37	2	70-20622	3/8" Flange Hex Nut Gr 5 NC
38	8	70-20627	3/4" Flange Nut

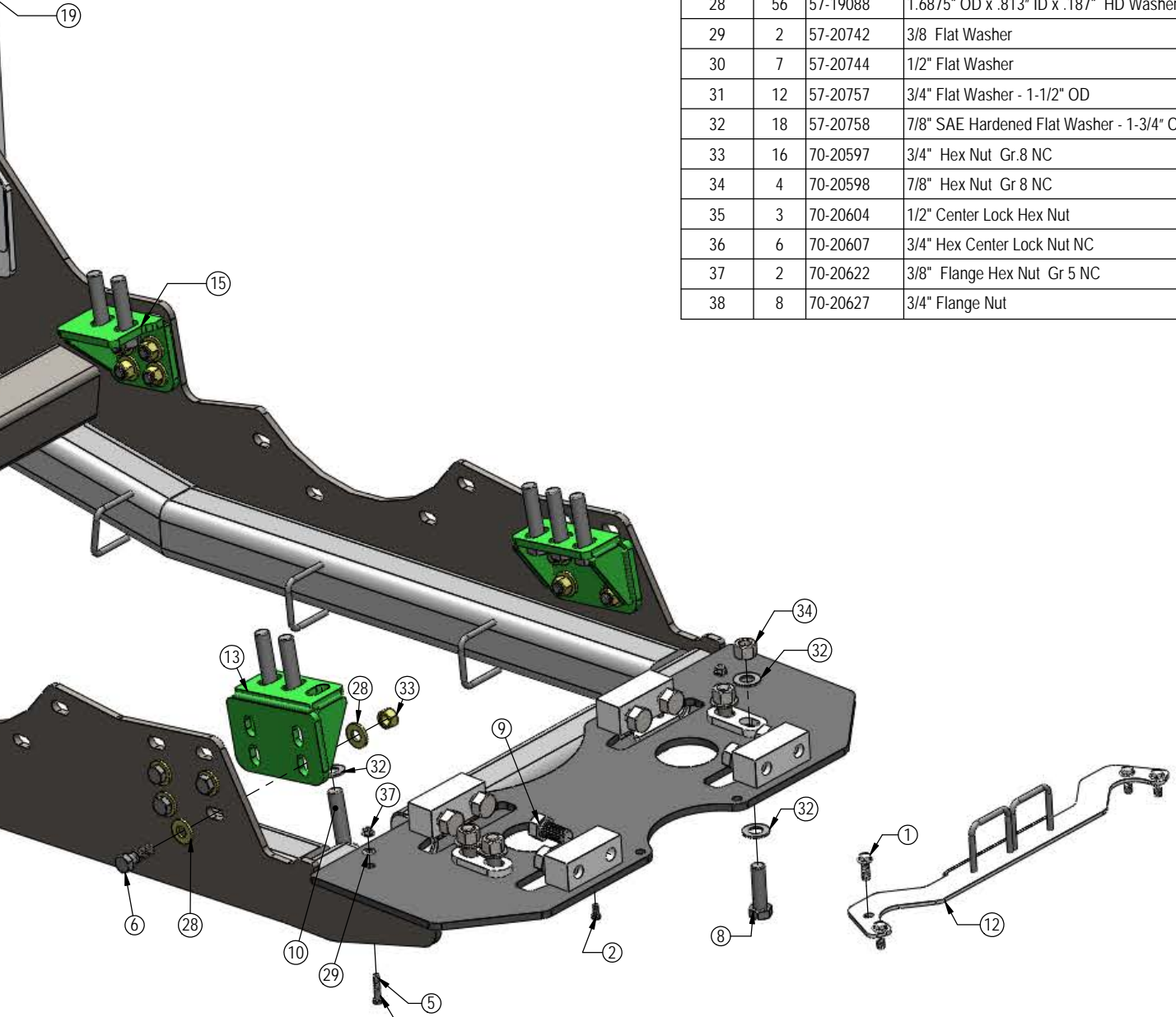

Use Original Washer, Spacer and Cable Holder from Tractor

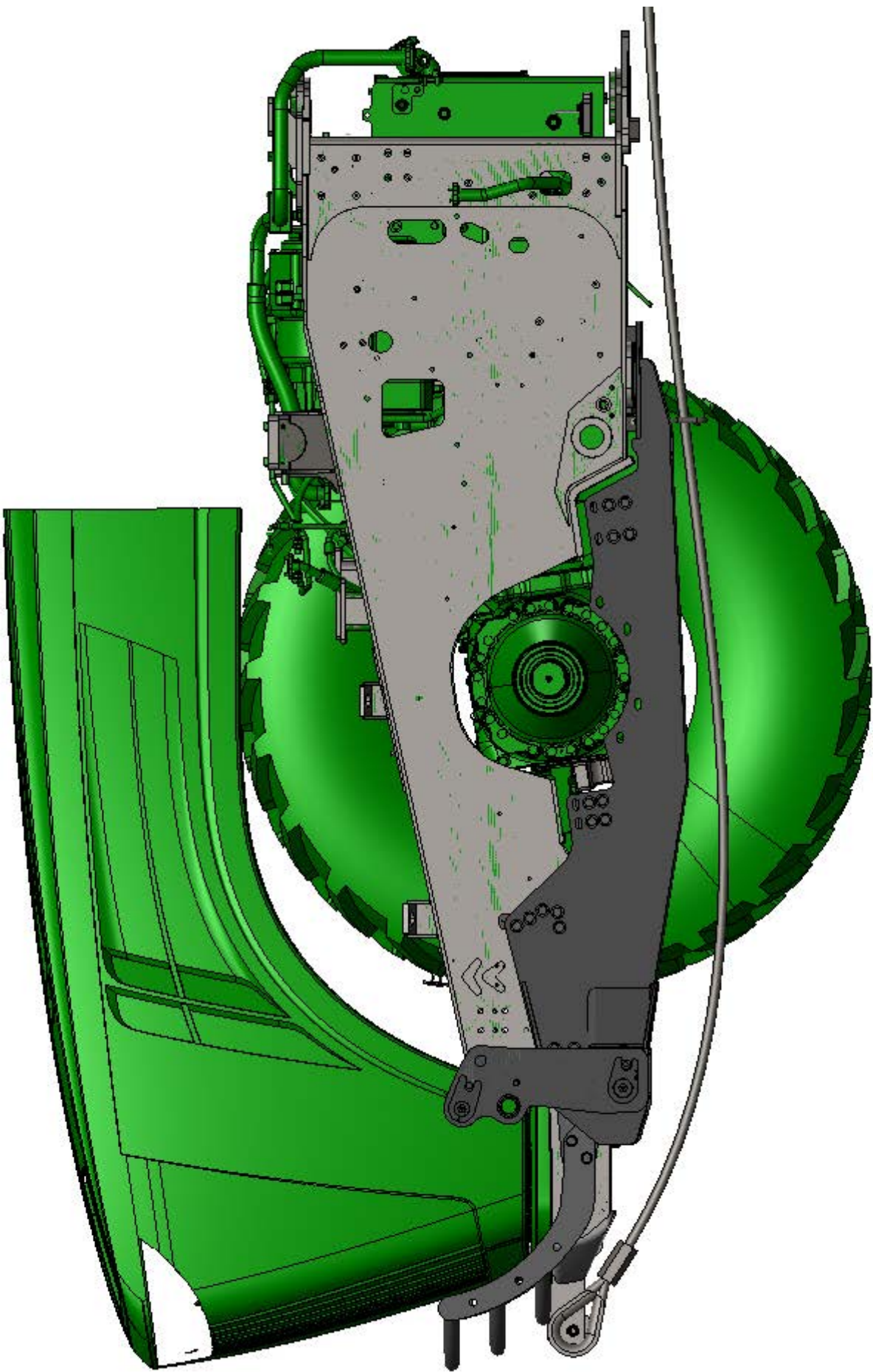

Assembling Lift Components

Refer to the Ag Pro Plus Owner's Manual & Parts Book for instructions on how to assemble the lift components.

Tow Cable Components

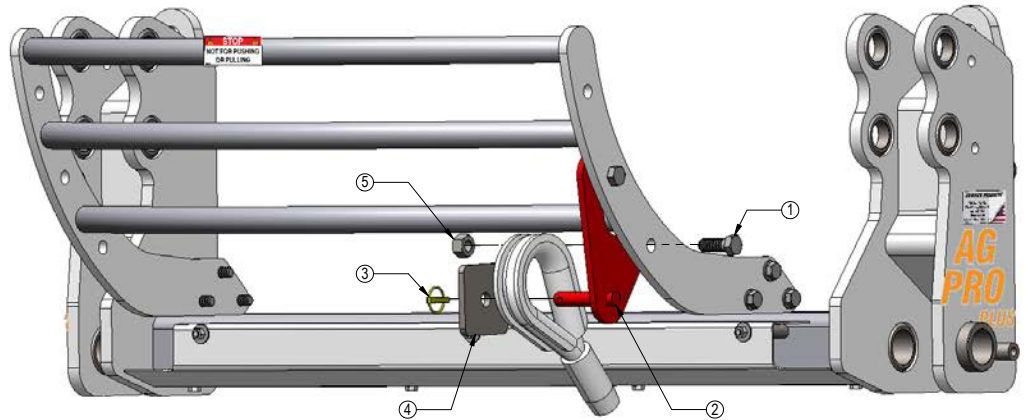

Item No.	Qty.	Part No.	Description
1	2	16-20540	7/8" X 2-1/2" Hex Bolt Gr 8 NC
2	1	18-19095	Tow Cable Bracket
3	1	43-16764	7/16" x 1-3/4" Lynch Pin
4	1	44-15585	Tow Cable Holding Plate
5	2	70-20598	7/8" Hex Nut Gr 8 NC

Notes

Contact Us

As always, if you have any questions about your Ag Pro Plus Dozer or other products made by Grouser, feel free to contact us.

Grouser Products

755 2nd Ave NW - West Fargo, ND 58078

Phone: 1-800-747-6182

Fax: 1-701-282-8131

E-mail: grouser@grouser.com

Website: www.grouser.com



Improvements

Grouser Products Inc. is continually striving to improve its products. We reserve the right to change prices, specification, or equipment at any time without notice. We also reserve the right to make improvements or changes when it becomes practical and possible to do so without incurring any obligation to make changes or additions to the equipment sold previously.

Warranty

Grouser Products warrants to the original purchaser of each item that the product be free from defects in material and workmanship under normal use and service for a period of two years from date of original retail delivery. If such equipment is found to be defective within two years, it is the obligation of Grouser Products under this warranty to repair or replace (exclusive of the cost of labor and transportation), any equipment or parts, in the judgment of Grouser Products to be defective in material or workmanship.

All equipment or parts claimed to be defective in material or workmanship must be made available for inspection at the place of business of a dealer authorized to handle the equipment covered by this warranty, or, upon request by Grouser Products, shipped to the Grouser Products factory in West Fargo, North Dakota. Grouser Products shall have no obligation to bear the cost of labor or transportation in connection with replacement or repair of any such defective parts in the setup process.

This warranty covers only defects in material and workmanship. It does not cover depreciation or damage caused by normal wear, accident, improper assembly, improper adjustments, improper maintenance including lack of proper lubrication, or improper use. Therefore, Grouser Products liability under this warranty shall not be effective or actionable unless the equipment is assembled, maintained and operated in accordance with the operating instructions accompanying the equipment. Grouser Products shall have no liability if the equipment has been altered or reworked without the written authorization of Grouser Products.

Grouser Products' parts, which are furnished under this warranty and properly installed, shall be warranted to the same extent as the original parts under this warranty if, and only if, such parts are found to be defective within the original warranty period covering the original equipment.

