



Ag Pro Plus/Ag Pro SS Steiger Rowtrac 350-500

Undercarriage Installation Instructions

For Models:

Steiger Rowtrac: 350, 370, 400, 420, 450, 470, 500

Purchase Date
Serial Number
Model Number
Tractor Model
Dealer

Contents

Description	Page
To The Owner, Maintenance & Torque Specifications _____	2
Safety Precautions & Unpacking Components _____	3
Undercarriage Installation Instructions _____	4-9
Lift Components, Tow Cable Components & Notes _____	10-11
Contact Us, Improvements, & Warranty _____	12

To The Owner

This manual contains information concerning the operation, adjustment, and maintenance of the Ag Pro Plus dozer system. You have purchased dependable, long lasting equipment, but only by proper care and operation can you expect to receive the performance and long service built into our products. Please have all operators read this manual carefully and keep the manual available for ready reference. If you have any questions or concerns, contact Grouser Products.

Maintenance

Due to the harsh environment this equipment operates in, the following tasks should be performed every 10 hours or less.

- Inspect all equipment before operation for existing or potential damages.
- Lubricate all joints with high quality grease.
- Inspect and tighten all bolts to torque specifications listed below.
- Make sure all non-rotating pins are secured properly.
- Check hydraulic cylinders and hoses for damage or leaks. For replacement parts, see hydraulic pages for your specific system.

Torque Specifications

All bolts should be tightened to the specifications that are stated. If specifications are not stated, follow torque charts below.

Size	Torque - Dry (ft-lbs)			
	SAE Grade 5		SAE Grade 8	
	UNC	UNF	UNC	UNF
5/16	19	20	29	31
3/8	33	36	47	51
7/16	54	58	78	85
1/2	78	85	119	129
9/16	114	124	169	184
5/8	154	167	230	250
3/4	257	280	380	414
7/8	382	416	600	654
1	587	639	903	984

	Torque - Dry (ft-lbs)
Size	Grade 10.9
M18 x 2.00	236
M20 x 2.50	432
M22 x 2.50	394
M24 x 3.00	570

Safety Precautions

A careful operator is the best operator. Most accidents can be avoided by observing certain precautions. To help prevent accidents, read and take the following precautions before operating this equipment. In addition to these precautions, please follow all safety and operational instructions supply by your tractor manufacturer.

The Dozer:

1. The Ag Pro Plus Dozer should be operated only by those who are responsible and instructed to do so.
2. Read the owner's manual carefully before using this equipment. Lack of operating knowledge can lead to accidents.
3. Keep the dozer maintained and in good condition to ensure your safety.
4. Make sure the area around you is clear of people before moving any equipment.
5. Do not modify or permit anyone else to modify or alter the equipment and its components without first consulting Grouser Products.

Servicing the Dozer:

1. Read and follow all safety instructions provided by the tractor manufacturer.
2. Always use proper personal safety gear when performing maintenance on equipment.
3. Before servicing, relieve hydraulic pressure, stop engine and fully engage parking brake.
4. Escaping hydraulic fluid under pressure can penetrate skin causing serious injury. If fluid is injected into skin, obtain medical attention immediately.
 - DO NOT use your hand to check for leaks. Use a piece of cardboard or paper to search for leaks.
 - Stop the engine and relieve trapped hydraulic pressure before connecting or disconnecting lines.
 - Tighten all connections before starting the engine or pressurizing lines.

Storing the Dozer:

1. Thoroughly clean the dozer before storage. Use paint where necessary to prevent rust.
2. Check for worn or damaged parts. Install new parts as required.
3. Lubricate all pins and joints.

Unpacking Components

Unstrap and remove any components that are attached for shipping. If any components are missing, call Grouser.

Caution:

- Always use caution when working around any equipment.
 - Always wear safety glasses.
 - Follow tractor manufacturer's safety guidelines when installing this product.
1. Read all instructions prior to performing installation.
 2. If applicable, remove front weights, weight bracket, and toolbox. If a tow cable kit was purchased from Grouser, the tow cable will be reinstalled in a later step.

NOTE: When installing hardware, only finger tighten until you get to the torquing steps.

NOTE: A full diagram of the assembly with the full list of parts is on Page 8.

NOTE: Tractor frame not shown in some diagrams for clarity.

3. Remove brackets from the undercarriage to make room for installing the undercarriage on the tractor and unscrew the 1" vertical bolts at the rear of the undercarriage.
4. Position undercarriage under tractor, center on the frame of the tractor.

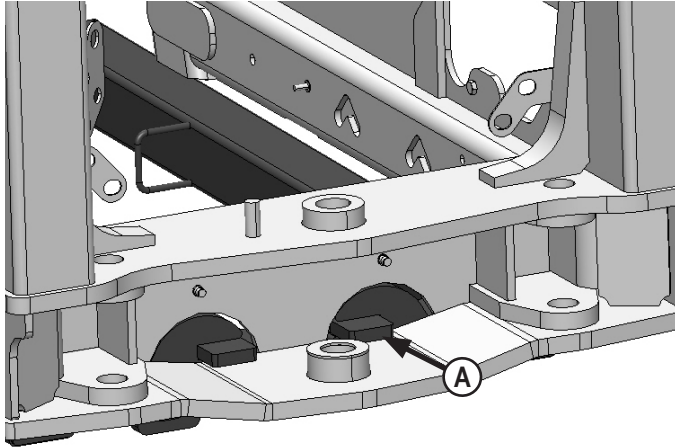

5. Lift the rear of the undercarriage up and set the top plates at the rear of the undercarriage on the tractor cross member (A). Push the undercarriage back until the vertical push plates are firmly against the cross member.

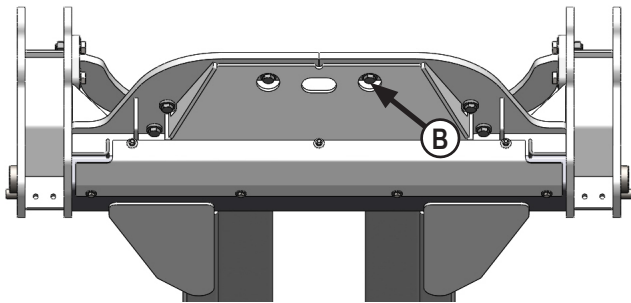

6. Lift the front of the undercarriage up and install 8 - 20mm x 90mm bolts and 8 - .375" thick washer from the bottom through the front slots of the undercarriage that line up with the vertical holes on the tractor frame (B).

7. After all 8 bolts are through the tractor frame, attach with 8 - 3/4" hardened washers and 8 - 20mm nuts from the top. Verify that the rear of the undercarriage is still firmly against the cross member.

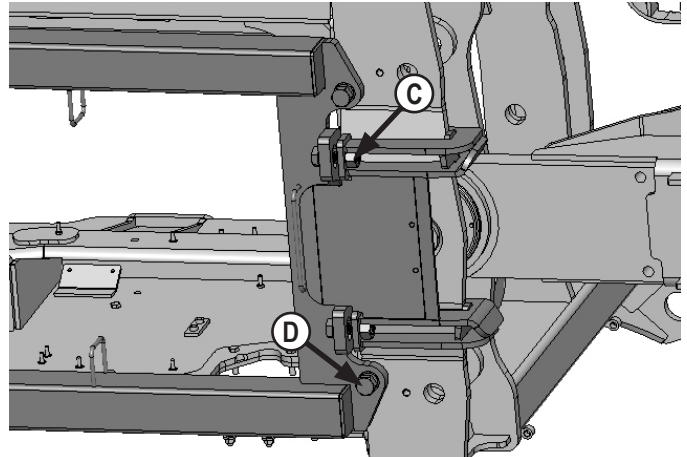

8. At the rear of the undercarriage and pivot area of the tractor, hook the rear hose routing bracket to the tractor frame and bolt to the rear of the undercarriage with 2 - 1" x 3" bolts, 2 - 1" hardened washers, and 2 - 1" nuts. The nut will fit between the plates on the brackets (C).

9. Center the bracket on the undercarriage and tractor as close as you can.

10. Torque the 1" bolts on the bracket to 903 ft-lbs. There can be a gap between the bracket and the undercarriage.

11. Tighten the 1" x 2" vertical at the rear of the undercarriage (D).

12. Torque the rear vertical 1" bolts to 500-600 ft-lbs.

13. Torque the front vertical 20mm bolts to 432 ft-lbs.

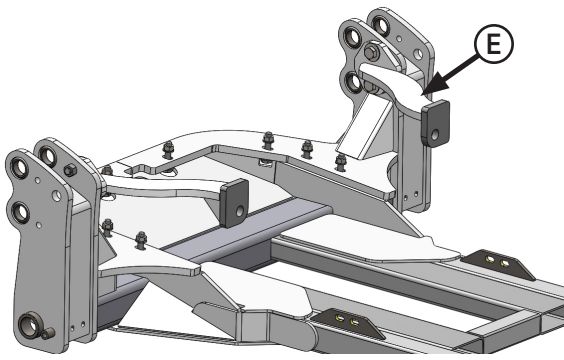

14. Attach the front upper support arms to the undercarriage with 2 - 1" x 3-1/4" bolts, 2 - 1" hardened flat washers, and a 1" nut on the top bolt on each side (E).

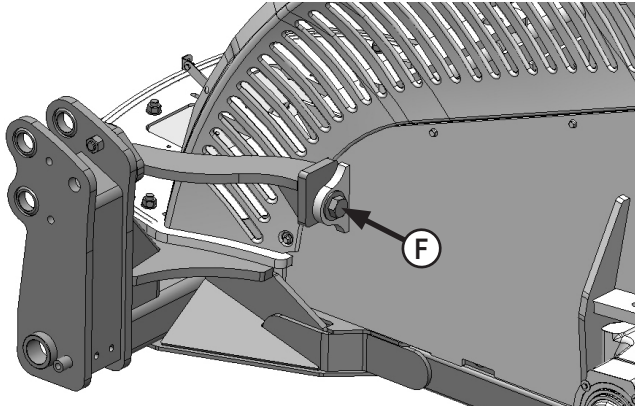

15. Attach the front upper support arms to the tractor with 2 - 1-1/4" x 4-1/2" bolt, 2 - 1-1/4" flat washer, and 2 - 1-1/4" nuts (F).

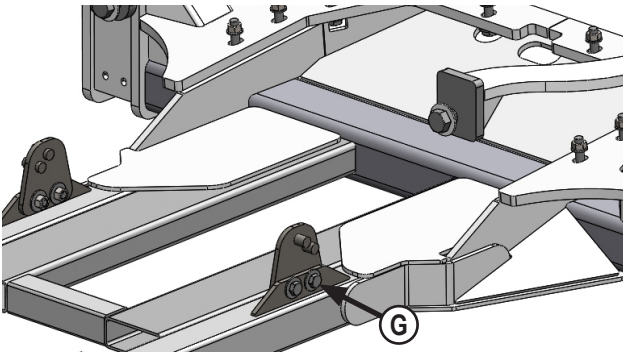

16. Install the front side tube bracket on each side of the undercarriage. The pins on the bracket will fit into the chain down hook on the inside of the tractor frame. Attach to the undercarriage with 2 - 3/4" x 2" bolts, 4 - 3/4" flat washers, and 2 - 3/4" lock nuts on each side (G).

17. Torque the upper support arm 1-1/4" bolts to 1,105 ft-lbs.

18. Torque the upper support arm 1" bolts to 903 ft-lbs.

19. Torque the side tube bracket 3/4" bolts to 257 ft-lbs.



20. Attach the rear hose routing plate to the tractor frame behind the pivot point and before the drawbar. There will be 2 bolts sticking down. Attach with 2 - 20mm nuts (H). Make sure the lip of the plate is facing towards the front of the tractor.

21. Torque the 20mm nuts to 432 ft-lbs.

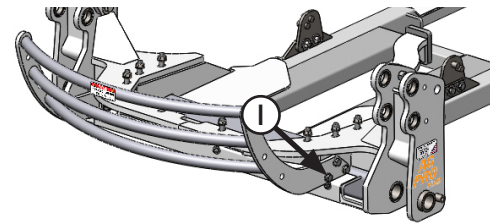

22. Install the grill guard to the front of the undercarriage with 3 - 3/4" x 2-1/2" bolts, 6 - 3/4" flat washers, and 3 - 3/4" lock nuts on each side (I).

23. Torque the 3/4" bolts to 257 ft-lbs.

NOTE: If applicable, refer to Page 11 to attach the front of the tow cable.

24. After first 8 hours of use, re-torque all bolts.

25. Check all fasteners regularly to ensure proper operation of equipment.

Hose Routing

1. Route hoses through the hose loops on the undercarriage and through the large loop at the rear of the undercarriage.

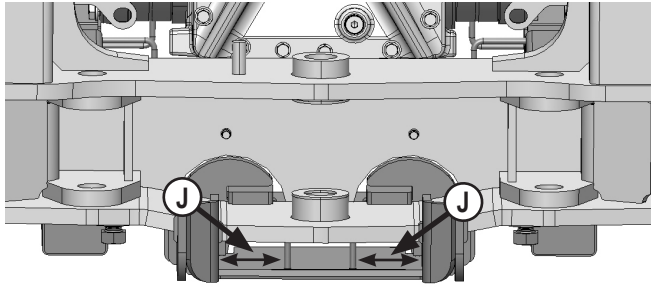

2. Send hoses through the bracket at the pivot point but stay on the outside of the rods that are by the center large nut on the tractor. The hoses should be between the rods and the inside plates of the bracket (J).

3. Route the hoses through the hose routing plate that was installed in Step #20 on Page 5.

4. Use Zip Ties to group some hoses on the left and right side of the hose routing plate. Strap the Zip Ties over the top part of the routing plate that is bolted to the tractor frame to keep the hoses towards the outside of each side of the routing plate.

5. Continue to route the hoses down the top of the drawbar to the back of the tractor where you can plug them into the tractor SCV Ports.

NOTE: Refer to diagram at the bottom of the page if clarification is needed for Step #6-11.

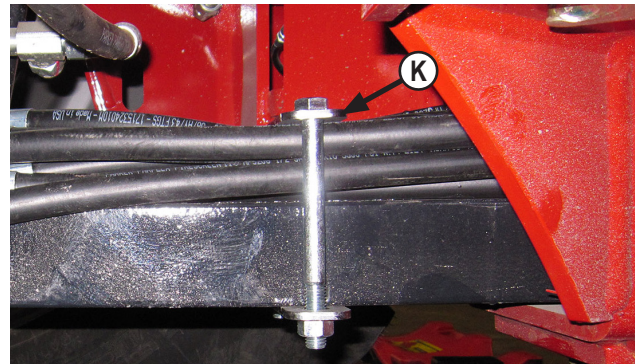

6. Strap the hoses to the drawbar with a set of hose holding plates in 2 locations (K). Place 1 set as close to the front of the drawbar as possible and the other behind the axle before the hoses would be routed upwards to be plugged in.

7. Make sure to keep some slack in the hose between the pivot point of the tractor and the first set of hose holding plates. The hoses will move when the tractor moves and oscillates.

8. For each set of plates, use 2 - 1/2" x 5-1/2" bolts and 2 - 1/2" lock nuts. If you have a 12-20 or 3-5 dozer blade, use 1/2" x 6" bolts in place of the 5-1/2" bolts.

9. Tighten the 1/2" nuts so the hoses are tight and don't move. If you have the nuts as far as they go and can't get the plates tight against the hoses, use the provided 3/4" spacers and 1/2" washers between the plates and the nuts to get everything tight against the drawbar. Refer to drawing on pages 8-9 for clarification.

10. Make sure you still have some slack in the hoses by the pivot area so the hoses don't get pulled too tight when the tractor moves but don't make them too loose that they will get caught on any debris. Turn the tractor and oscillate the tractor to verify there is enough slack.

11. Plug the hoses into the open SCV's at the back of the tractor.

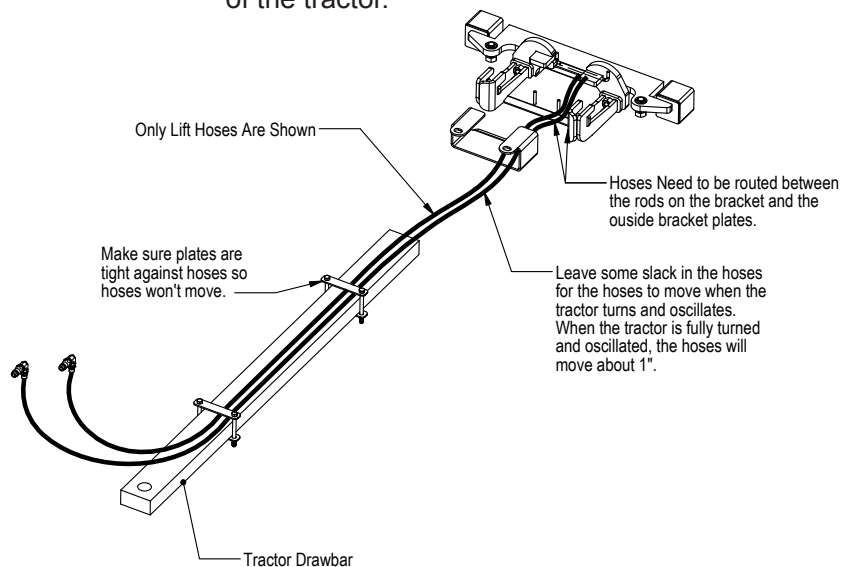

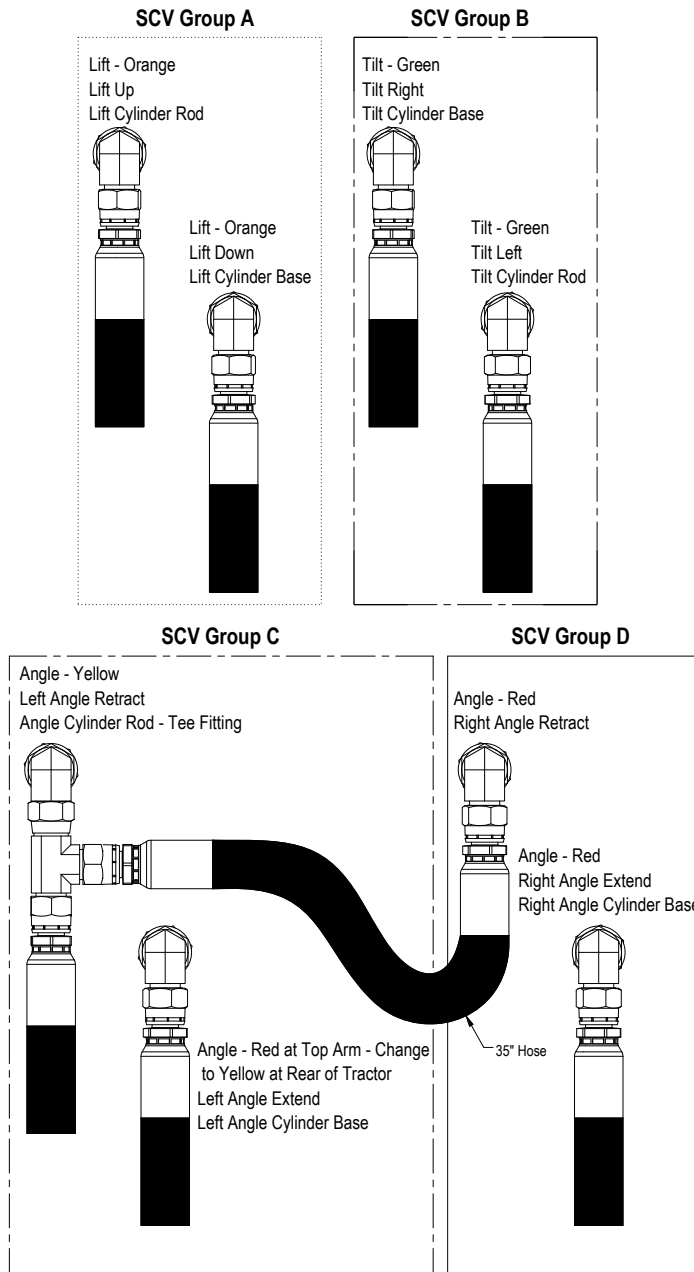

Hoses Not Drawn To Scale

NOTE: The quantity of hoses may vary depending on blade system.

NOTE: If blade system has Dual Remote Hydraulic Angle, verify that the 35" hose is used and installed correctly. Refer to hydraulic schematic in the Owner's Manual & Parts Book if necessary.

See Detail A Below

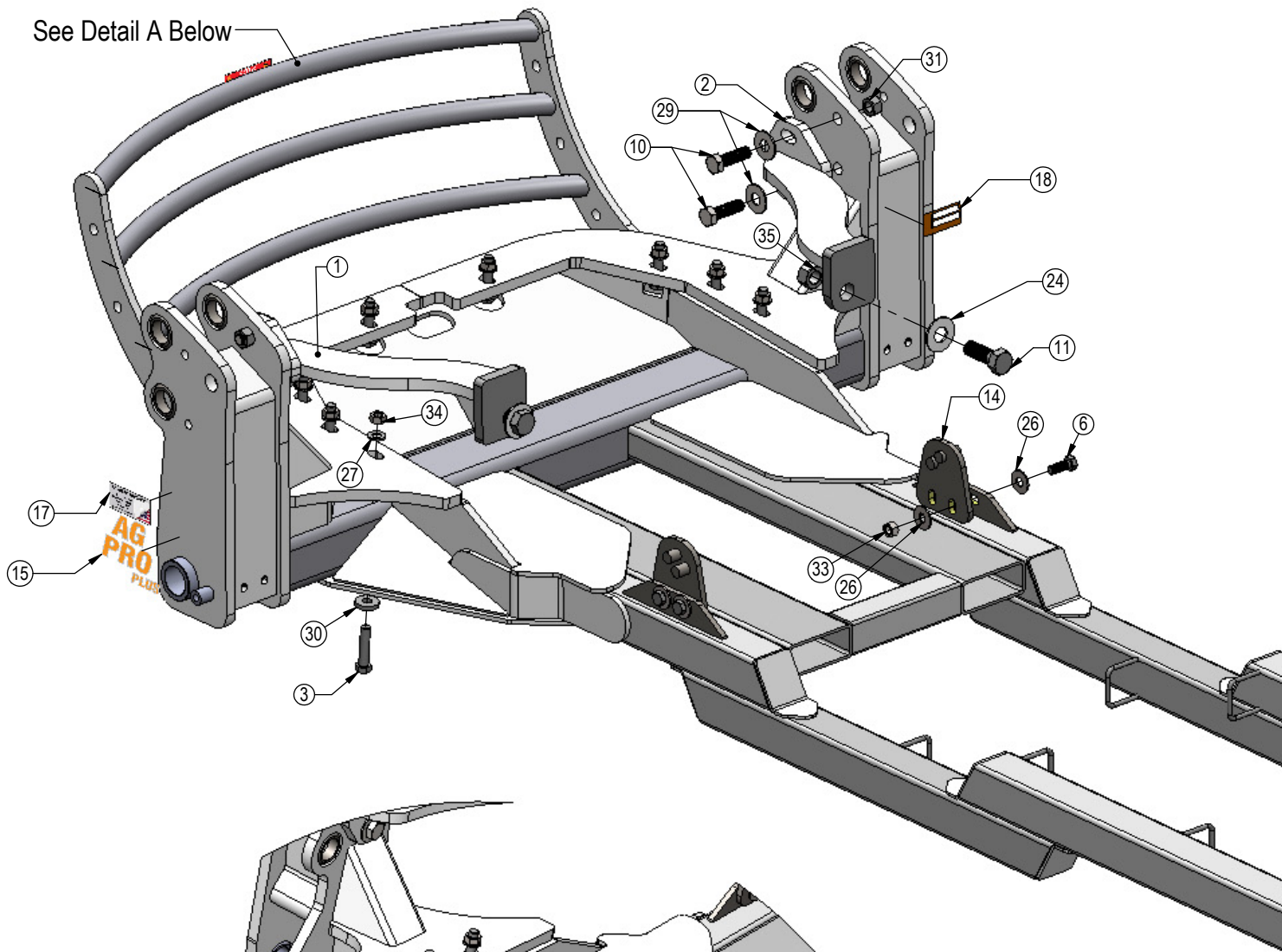

DETAIL A

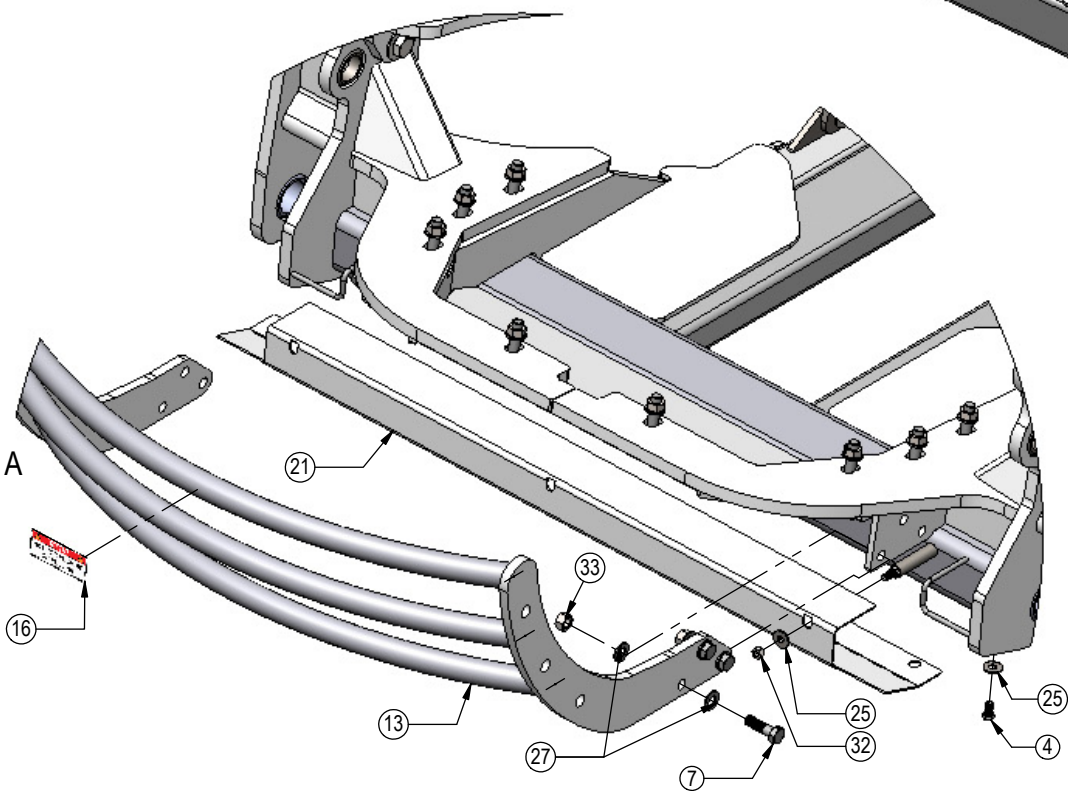

ITEM NO.	PART NO.	QTY.	DESCRIPTION
1	11-19170-L	1	Support Arm
2	11-19170-R	1	Support Arm
3	16-1510	8	20mm x 2.5mm x 90mm Hex Bolt
4	16-20124	4	1/2" x 1" Hex Bolt Gr.5 NC
5	16-20139	4	1/2" x 5-1/2" Hex Bolt Gr 5 NC
6	16-20218	4	3/4" x 2" Hex Bolt Gr.5 NC
7	16-20220	6	3/4" x 2-1/2" Hex Bolt Gr 5 NC
8	16-20558	2	1" x 2" Hex Bolt Gr. 8 NC
9	16-20562	2	1" x 3" Hex Bolt Gr.8 NC
10	16-20563	4	1" x 3-1/4" Hex Bolt Gr.8 NC
11	16-20896	2	1-1/4" x 3-1/2" Hex Bolt Gr.5 NC
12	18-17295R2	1	Rear Bracket
13	18-18059R1	1	Grill Guard Weld
14	18-18678	2	Bracket
15	27-18880	2	Ag Pro Plus Decal
16	27-18882	1	Not For Pushing or Pulling Decal
17	27-18887	1	Grouser Name Plate Decal
18	27-9506	1	Serial Tag Decal
19	44-17208R1	1	Plate
20	44-17245	4	Plate
21	44-19486	1	Plate, Cover
22	53-15528	4	Round Tube
23	54-19960	1	Rowtrac UC Weld
24	57-11671	2	1-1/4" Flat Washer
25	57-20744	11	1/2" Flat Washer
26	57-20747	8	3/4" Flat Washer
27	57-20757	20	3/4" Flat Washer - 1-1/2" OD
28	57-20759	2	1.00" Flat Washer-2" OD
29	57-20819	4	1" Flat Washer Heavy Duty Gr 8 (USS)
30	57-3680	8	3/4" ID x 2.00 OD x .375" Heavy Washer CZ Plated
31	70-20599	4	1" Hex Nut Gr 8 NC
32	70-20604	7	1/2" Center Lock Hex Nut
33	70-20607	10	3/4" Center Lock Hex Nut NC
34	70-20872-10	10	20mm Hex Nut 2.5 Pitch Class 10 Zinc
35	70-20981	2	1-1/4" Hex Nut Gr 5 NC
36*	16-20140	4	1/2" X 6" Hex Bolt Gr 5 NC

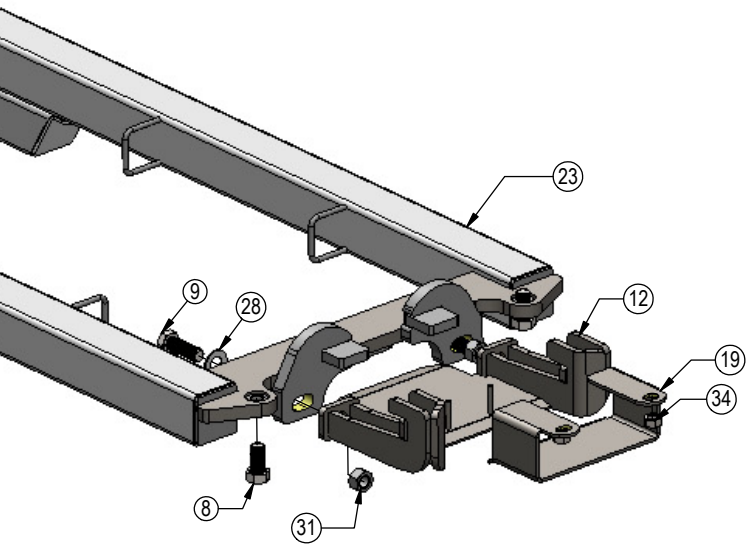

Item #36 - Used only with 12-20 Dozer Hydraulics in place of Item #5

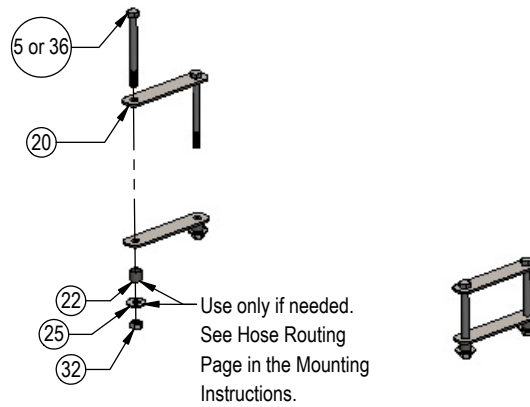

DWG. NO.: 19960-A

Assembling Lift Components

Refer to the Ag Pro Plus Owner's Manual & Parts Book for instructions on how to assemble the lift components.

Tow Cable Components

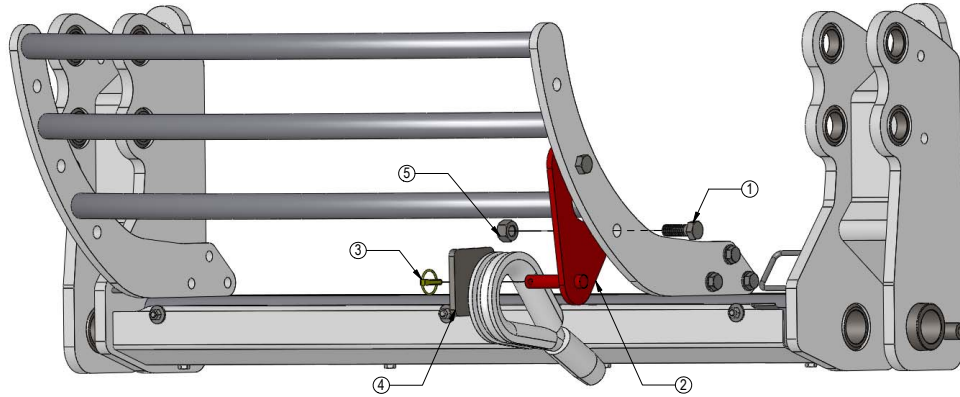

Item No.	Qty.	Part No.	Description
1	2	16-20540	7/8" X 2-1/2" Hex Bolt Gr 8 NC
2	1	18-19095	Tow Cable Bracket
3	1	43-16764	7/16" x 1-3/4" Lynch Pin
4	1	44-15585	Tow Cable Holding Plate
5	2	70-20598	7/8" Hex Nut Gr 8 NC

Notes

Improvements

Grouser Products Inc. is continually striving to improve its products. We reserve the right to change prices, specification, or equipment at any time without notice. We also reserve the right to make improvements or changes when it becomes practical and possible to do so without incurring any obligation to make changes or additions to the equipment sold previously.

Warranty

Grouser Products warrants to the original purchaser of each item that the product be free from defects in material and workmanship under normal use and service for a period of **two (2) years for Agriculture Series Blades and one (1) year for Heavy Duty Series from date of original retail delivery.**

The obligation of the consumer under this warranty:

1. To read the operators manual and to operate, lubricate, maintain and store equipment in accordance with the instructions listed in the operators manual.
2. To inspect equipment and if any part needs repair or replacement when continued use would cause damage or wear to other parts or safety.
3. All equipment or parts claimed to be defective in material or workmanship must be made available for inspection at the place of business of a dealer authorized to handle the equipment covered by this warranty, or, upon request by Grouser Products, shipped to the Grouser Products factory in West Fargo, North Dakota.

The obligation of the dealer under this warranty:

1. Complete warranty registration form and submit within 30 days of sale.
2. Contact Grouser Products for authorization prior to performing any warranty repairs or part replacement.
3. Complete warranty request form and submit with photos and supporting documentation.

The obligation of Grouser Products under this warranty:

1. Repair or replace, any equipment or parts, in the judgment of Grouser Products to be defective in material or workmanship.
2. Grouser Products will cover the cost of parts and ground shipping at dealer invoice only.
3. Grouser Products shall have no obligation to bear the cost of labor or transportation in connection with replacement or repair of any such defective parts.

This warranty does not cover:

1. Depreciation or damage caused by normal wear, accident, improper assembly, improper adjustments.
2. Improper maintenance including lack of proper lubrication, or improper use. Including loose bolts, nuts, or fitting due to over tightening or vibration after 20 hours of operation.
3. Repairs or alterations without authorization from a Grouser Products representative.
4. Grouser Products shall have no liability if the equipment has been altered or reworked without the written authorization of Grouser Products.

Grouser Products' parts, which are furnished under this warranty and properly installed, shall be warranted to the same extent as the original parts under this warranty if, and only if, such parts are found to be defective within the original warranty period covering the original equipment.

NO EMPLOYEE OR REPRESENTATIVE OF GROUSER PRODUCTS IS AUTHORIZED TO CHANGE THE WARRANTY IN ANY WAY OR GRANT ANY OTHER WARRANTY.

Contact Us

As always, if you have any questions about your system or other products made by Grouser, feel free to contact us.



755 2nd Ave NW - West Fargo, ND 58078
+1 701-282-7710 | info@grouser.com
www.grouser.com