



FH-440 John Deere 8R - IT4 & FT4 with IVT / E23

Undercarriage Installation Instructions

Caution:

- Always use precaution when working around any equipment.
- Always wear safety glasses.
- Follow tractor manufacturer's safety guidelines when installing this product.
 1. Read all instructions prior to installation.
 2. Remove weights and weight bracket from front of tractor if necessary.
 3. Remove toolbox from left side of tractor and the implement quick coupler from the right side if necessary.
 4. Attach the tail brackets (PN: 18-17095-R,L) to the tractor with 2 - 20mm x 50mm bolts (PN: 16-1878) and 2 - 3/4" flat washers (PN: 57-20747) on each side. See attached diagram for clarification. Reattach toolbox and implement quick coupler with the tail brackets if necessary

Be sure that the tail brackets are tight against bolt heads at rear of U/C.

NOTE: If applicable, remove ILS cylinder top grease fitting on each side and install new 90° grease fittings.

5. Attach the side rails (PN: 46-17155-R,L) to the side of the tractor with a 16mm x 90mm (PN: 16-1620090) and a 5/8" flat washer (PN: 57-20756) on each bolt through the top holes of the left and right rail and the tractor frame
6. Install 2 - 1" x 6" bolts (PN: 16-17271) into the threaded block at the end of undercarriage. Turn the 1" bolts in for installation. The bolts will be adjusted after the undercarriage is installed. See attached diagram for proper installation of the bolts.
7. Position the undercarriage under the tractor and center with the frame of the tractor.
8. Lift the front of the undercarriage until the holes on the tractor line up with the U/C holes.
9. At the front of the tractor, use 8 - 20mm x 70mm bolts (PN: 16-1876) with a 3/4" hardened flat washer (PN: 57-20757) on each bolt to attach the U/C to the front of the tractor.
10. Raise rear of undercarriage to attach the undercarriage to the side rails and tail brackets.
11. Attach the side rails to the undercarriage with 6 - 3/4" x 2-1/2" carriage bolts (PN: 16-21220), 6 - 3/4" hardened flat washers (PN: 57-20757) and 6 - 3/4" center lock nuts (PN: 70-20607) on each side. See attached diagram for clarification.

NOTE: Install carriage bolts from outside for proper clearance. Nut has to be on the inside of U/C.
12. Attach the tail brackets to the undercarriage with 6 - 3/4" x 2" carriage bolts (PN: 16-21218), 6 - 3/4" hardened flat washers (PN: 57-20757) and 6 - 3/4" center lock nuts (PN: 70-20607) on each side. See attached diagram for clarification. Install the bolts from the top.
13. Once all bolts are installed, torque the 16mm bolts to 269 ft-lbs., the front 20mm bolts to 432 ft-lbs, and the 3/4" bolts at the front to 257 ft-lbs.
14. Verify that the tail brackets are pushed all the way back and pushing against the tractor bolt heads.
15. Unsrew the 1" x 6" bolts at the rear of the undercarriage until they are tight against the tail brackets. Torque the 1" bolts to 90-95 ft-lbs.

- 16.** Install a 5/16" x 3/4" bolt (PN: 16-20032) into each block at the rear of the undercarriage to hold the 1" x 6" bolt in place.
- 17.** Torque the rear 20mm bolts to 432 ft-lbs, and the 3/4" bolts attaching the rear tail brackets to the undercarriage to 257 ft-lbs.
- 18.** After first 8 hours of use, re-torque all bolts.
- 19.** Check all fasteners regularly to ensure proper operation of equipment.

THE INFORMATION CONTAINED IN THIS DRAWING IS THE SOLE PROPERTY OF GROUSER PRODUCTS INC ANY REPRODUCTION IN PART OR WHOLE WITHOUT THE WRITTEN PERMISSION OF GROUSER PRODUCTS INC IS PROHIBITED.

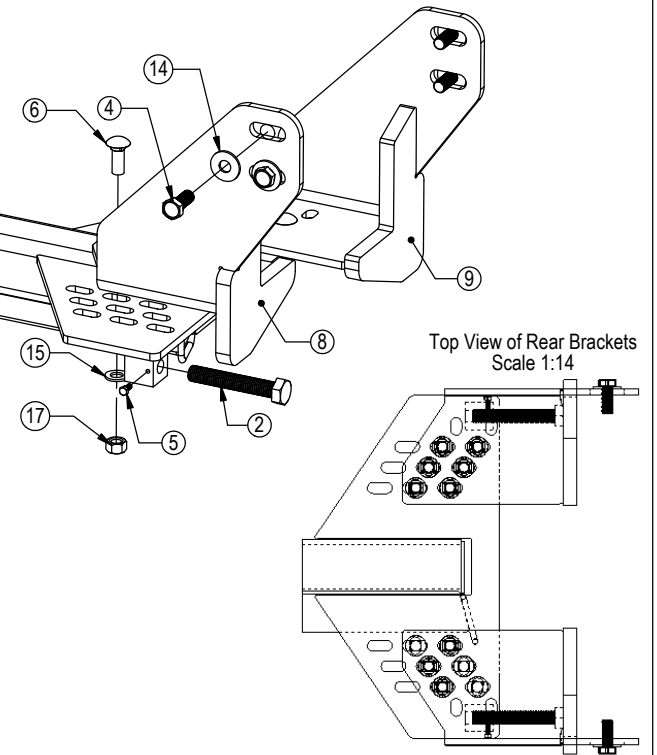
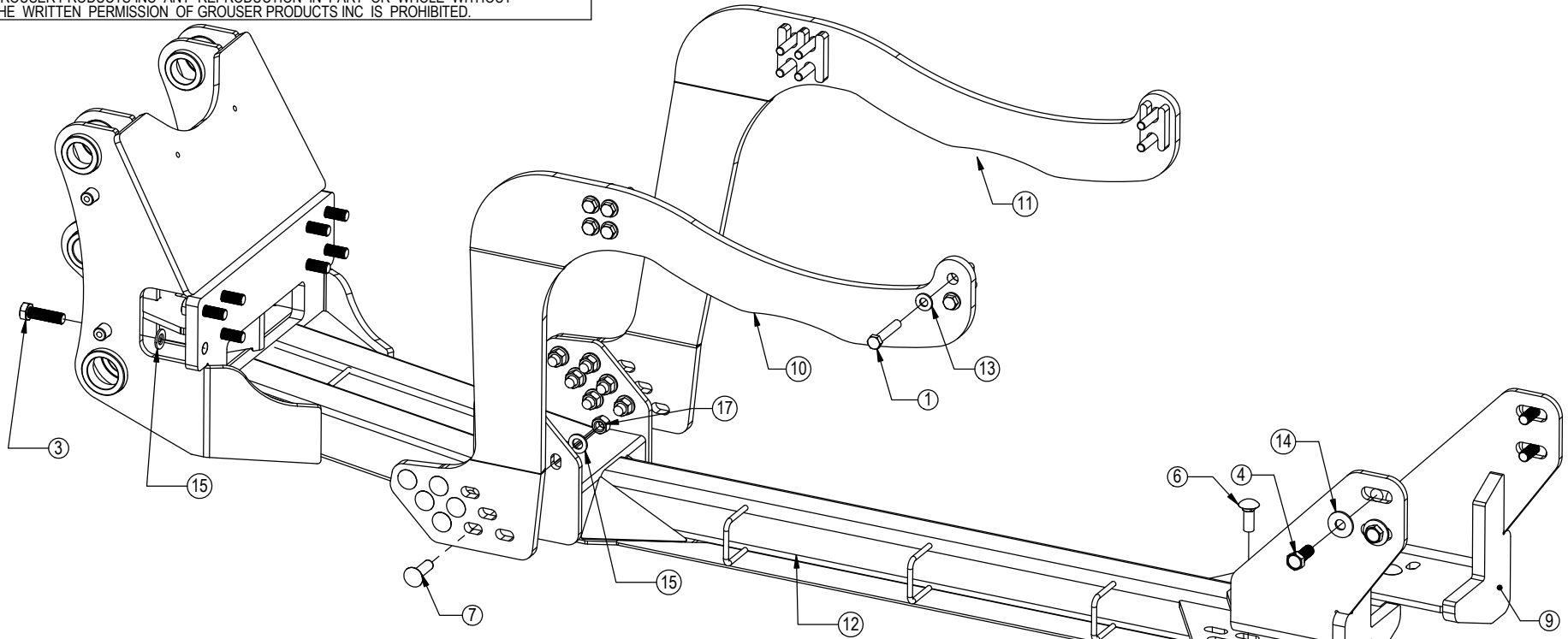

* Part Not Shown

Item No.	Qty.	Part No.	Description
1	12	16-1620090	16mm x 2.00mm x 90mm Metric Hex Bolt Gr 10.9 Coarse
2	2	16-17271	1" x 6" Hex Bolt Gr 8 NC (Full Thread)
3	8	16-1876	20mm x 2.5mm x 70mm Metric Hex Bolt Gr 10.9
4	4	16-1878	20mm x 2.5mm x 50mm Metric Hex Bolt Gr 10.9
5	2	16-20032	5/16" x 3/4" Hex Bolt Gr 5 NC
6	12	16-21218	3/4" x 2" Carriage Bolt GR 5 NC
7	12	16-21220	3/4" x 2-1/2" Carriage Bolt GR 5 NC
8	1	18-17095-L	FH-440 JD 8030 & 8R Tail Section - Left
9	1	18-17095-R	FH-440 JD 8030 & 8R Tail Section - Right
10	1	46-17155-L	FH-440 JD 8030 & 8R Side Plate Rail Left Weld
11	1	46-17155-R	FH-440 JD 8030 & 8R Side Plate Rail Right Weld
12	1	54-18310	FH-440 UC JD 8030 & 8R
13	12	57-20756	5/8" SAE Hardened Flat Washer - 1-5/16" OD
14	4	57-20747	3/4" Flat Washer
15	32	57-20757	3/4" SAE Hardened Flat Washer - 1-1/2" OD
16*	2	58-9372	Grease Zerk 1/8" NPT 90°
17	24	70-20607	3/4" Hex Center Lock Nut Gr 5 NC



GROUSER PRODUCTS INC.

755 2nd Ave NW Phone 701.282.7710
 West Fargo, ND 58078 Fax 701.282.8131
 WWW.GROUSER.COM

TITLE: JD 8R IT4 & FT4 - IVT / E23

Date: 2/23/2015

DWG. NO.: 18310-A