



Ag Pro SS Lift System

Owner's Manual & Parts Book

Grouser Products

755 2nd Ave NW - West Fargo, ND 58078

Phone: 1-800-747-6182

Fax: 1-701-282-8131

E-mail: grouser@grouser.com

Website: www.grouser.com

Purchase Date
Serial Number
Model Number
Tractor Model
Dealer

Description	Page
Welcome To The Owner _____	2
Safety Precautions, Torque Specifications & Pre-Installation _____	3
Lift System _____	4
Tractor Side Hydraulics _____	5-7
Initial Startup _____	8
Hydraulic Schematics _____	9
Hydraulic Multi-Coupler Maintenance _____	10-11
Contact Us, Improvements, & Warranty _____	12

Thank you for your recent purchase of a Grouser Dozer. Welcome to the family of satisfied Grouser blade owners. Grouser Products is committed to offering quality products to help professionals in their daily jobs. We are also committed to providing you the highest level of customer satisfaction possible. Again, thank you for your patronage. We look forward to serving you.

This manual contains information concerning the operation, adjustment, safety and maintenance of the Dozer. You have purchased a dependable, long lasting piece of equipment. You can expect to receive long lasting performance and long service built into our products with proper care and operation. Please have all operators read and understand this manual carefully. Keep the manual available for reference. If, for any reason, you have questions or comments, we would be happy to hear from you. Call our toll-free number, 800-747-6182, or send us an e-mail at info@grouser.com. You can expect us to respond to your e-mail in a timely manner.

A careful operator is the best operator. Most accidents can be avoided by observing certain precautions. To help prevent accidents, read and take the following precautions before operating this equipment. In addition, please follow all safety and operational instructions of your tractor manufacturer.

The Dozer:

1. The Dozer should be operated only by those who are responsible and instructed to do so.
2. Read the owner’s manual carefully before using this equipment. Lack of operating knowledge can lead to accidents.
3. Keep the Dozer maintained in reliable and satisfactory condition to ensure your safety.
4. Make sure the area is clear of people before moving any equipment.
5. Do not modify or permit anyone else to modify or alter the equipment and its components without first consulting Grouser Products.
6. Lower the blade to the ground when not in use.

Servicing the Dozer:

1. Read and follow all safety instructions provided by the tractor manufacturer.
2. Always use proper personal safety gear when performing maintenance on equipment.
3. Before servicing, relieve hydraulic pressure, stop engine and fully engage parking brake.
4. Escaping hydraulic fluid under pressure can penetrate skin causing serious injury. If fluid is injected into skin, obtain medical attention immediately.
 - DO NOT use your hand to check for leaks. Use a piece of cardboard or paper to search for leaks.
 - Stop the engine and relieve pressure before connecting or disconnecting lines.
 - Tighten all connections before starting the engine or pressurizing lines.

Storing the Dozer:

1. Thoroughly clean the Dozer before storage. Use paint where necessary to prevent rust.
2. Check the Dozer for worn or damaged parts. Install new parts as required.
3. Lubricate all pins and joints.

Tighten all bolts to the values listed below unless otherwise noted. Refer to the parts lists for proper length and grade of the bolts.

Size	Torque - Dry (ft-lbs)			
	SAE Grade 5		SAE Grade 8	
	UNC	UNF	UNC	UNF
5/16	17	19	24	27
3/8	30	35	45	50
7/16	50	55	70	80
1/2	75	85	110	120
9/16	110	120	150	170
5/8	150	170	210	240
3/4	260	300	380	420
7/8	430	470	600	670
1	640	720	910	1020

Size	Torque - Dry (ft-lbs)
	Grade 10.9
M18 x 2.50	284
M20 x 2.50	401
M22 x 2.50	547
M24 x 3.00	694

Unstrap and remove the lift frame, hoses, top arms, and any boxes of hardware from the undercarriage. If any components are missing, call Grouser.

Install undercarriage per the tractor specific mounting instructions.

Some assembly of Lift System components is necessary. Follow the steps listed below. See diagram below for the correct hardware and orientation of parts.

1. Remove all pins and fasteners on each side of the undercarriage and set aside for later installation.
2. Position the lift frame between the two plates on both sides of the undercarriage and align to the bottom holes.
3. Insert pins and hardware to attach the lift frame, the base end of the lift cylinders, and the top arms to the undercarriage.
4. Insert pins and hardware to attach the male quick attaches to the lift frame, and to the top arms. Use 2" washers as shims to keep top arm pins tight and in place. Only use as many as needed until pin is tight.
5. Torque all fasteners according to the specifications on Page 3.

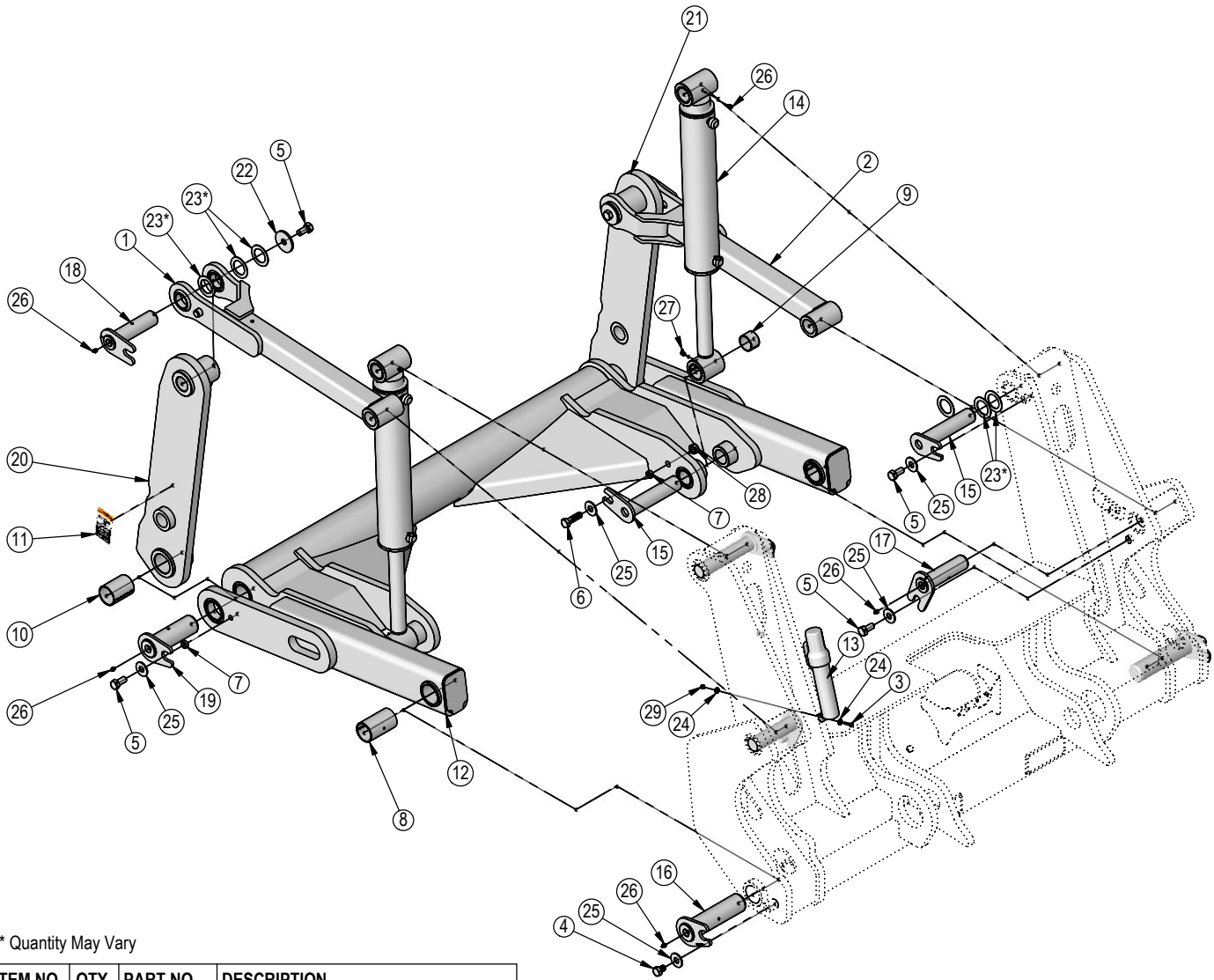

* Quantity May Vary

ITEM NO.	QTY.	PART NO.	DESCRIPTION
1	1	11-41920-L	Top Arm
2	1	11-41920-R	Top Arm
3	2	16-20005	1/4" x 1-1/4" Hex Bolt Gr 5 NC
4	2	16-20214	3/4" x 1" Hex Bolt Gr 5 NC
5	8	16-20216	3/4" x 1-1/2" Hex Bolt Gr 5 NC
6	2	16-20220	3/4" x 2-1/2" Hex Bolt Gr 5 NC
7	4	19-13515	Spacer, NR Pin
8	2	19-13525	2.75 x 2.50 x 4.75 Spring Bushing
9	8	19-16695	2.25 x 2.00 x 1.50 Spring Bushing
10	2	19-18089	2.75 x 2.50 x 3.75 Spring Bushing
11	2	27-9503	Pinch Decal (Foot)
12	1	32-41910	Lift Frame, Claas
13	1	34-14961	Manual Canister Small
14	2	34738	4 x 20 Hydraulic Cylinder
15	4	43-13478	Pin Weld

ITEM NO.	QTY.	PART NO.	DESCRIPTION
16	2	43-14725	Lift Frame / UC Pin
17	2	43-18120	Top Pin Weld
18	2	43-18127	Top Arm Pin Weld
19	2	43-18635	Ag Pro Plus QA Pin
20	1	45-18110-L	Male Quick Attach, Ag Pro S
21	1	45-18110-R	Male Quick Attach, Ag Pro S
22	2	57-1530	3" OD X .75 ID X .25" HD Flat Washer
23*	10	57-1811	2" Washer
24	4	57-20740	1/4" Flat Washer
25	10	57-20747	3/4" Flat Washer
26	10	58-9369	Straight 1/8" NPT Grease Zerk
27	2	58-9372	90° 1/8" NPT Grease Fitting
28	2	70-20607	3/4" Center Lock Hex Nut Gr 2 NC
29	2	70-20610	1/4" Nyloc Hex Nut Gr 5 NC

Note: Refer to Pages 6-8 for the correct hose lengths and hose location.

Note: All connections are identified by spiral bands. 2 bands are from the base end of a cylinder and 1 band is from the rod end of a cylinder. Orange = Lift, Green = Tilt, Red = Angle.

1. Connect the lift hoses to the lift cylinders.
2. Verify that hoses are not twisted and protected from rubbing on any sharp edges. See Pages 6-8 for proper hose routing.
3. Install the 45° fittings into the multi-couplers on both top arms.
4. Identify each remaining hose at the front of the undercarriage by the colored bands on the end of the hose and connect the hose to the corresponding 45° fitting on the multi-coupler. Refer to Pages 6-8 for proper hose locations.
5. Continue on Page 8 for initial startup instructions.

HAHT	Hydraulic Angle - Hydraulic Tilt
HANT	Hydraulic Angle - No Tilt
NAHT	No Angle - Hydraulic Tilt
NANT	No Angle - No Tilt

ITEM NO.	PART NO.	HAHT	DESCRIPTION
1	16-20037	1	5/16" x 2" Hex Bolt Gr 5 NC
2	16-20124	2	1/2" x 1" Hex Bolt Gr.5 NC
3	16-812525	2	8mm x 1.25mm x 25mm Metric Hex Bolt Gr 10.9
4	18-19311-03-P-087	2	Hose Clamp
5	18-19312-03	1	Twin Cover Plate
6	18-19313-03	1	Twin Stacking Bolt
7	18-19314-02	1	Twin Safety Plate
8	18-19995-L	1	Multi-Coupler Mount
9	25-19864	1	Multi-Coupling Plate - 4 Port Fixed
10	25-19870	-	Multi-Coupling Plate - Male Coupler
11	25-34342	6	Tappet Quick Coupler Male - Poppet Style
12	25-3453	2	Pioneer Dust Cap Tilt (Green)
13	25-3455	2	Pioneer Dust Cap Angle (Red)
14	25-3457	2	Pioneer Dust Cap Lift (Orange)
15	25-40407	-	Multi-Coupling Plate - Snap Ring
16	31-11699-10-8	2	JIC Union
17	31-15199-8-8	4	JIC Union Elbow 90°
18	31-34030	2	Bulkhead Run Tee JIC

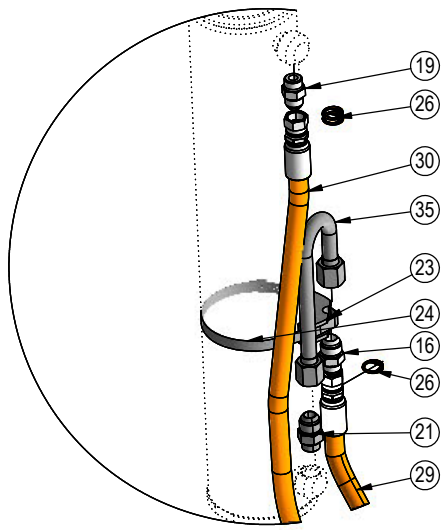

Hoses Not Drawn to Scale

Every hydraulic function from the front to the back of the system is designated by a **○** and a letter and can also be referenced on the Hydraulic Schematics on Page 9.

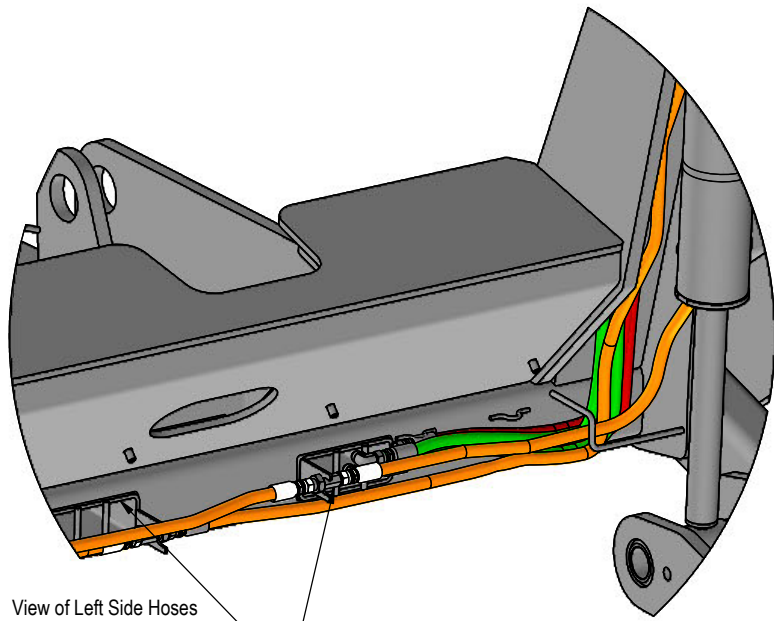

View of Left Side Hoses From The Front

Designated Hose Locations

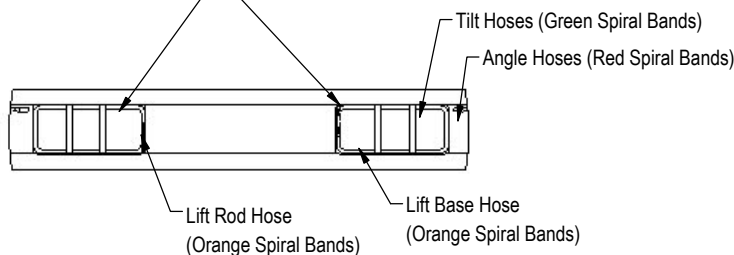

Detail B

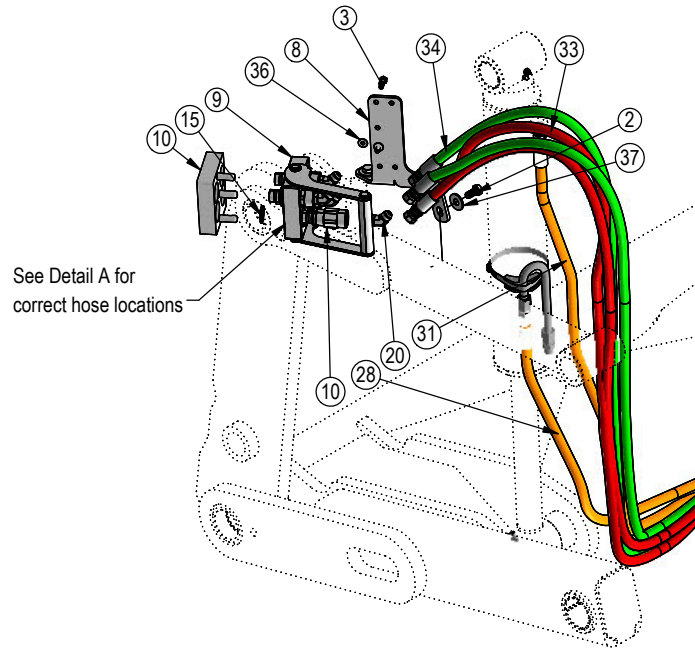

Detail A

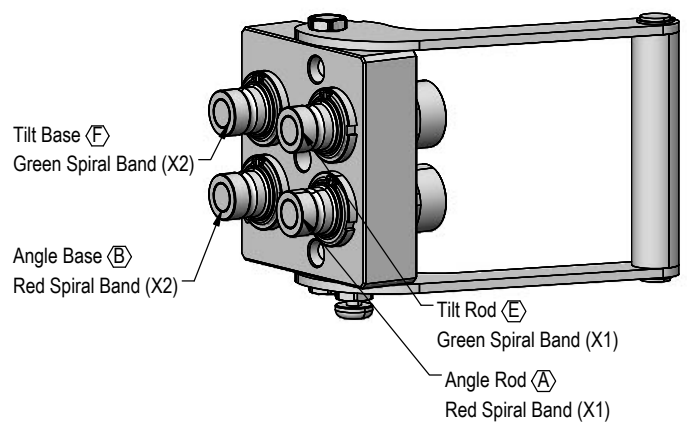

NOTE: All hoses are marked with colored spiral bands and should be attached to designated ports on the Multi-Coupler.

ITEM NO.	PART NO.	HAHT	DESCRIPTION
19	31-34040	2	Straight JIC x O-Ring
20	31-34150	4	Straight Thread Elbow 45° JIC x O-Ring
21	31-6400-10-08	2	Straight JIC x O-Ring
22	31-6802-08-10	6	Straight Thread Elbow 45° JIC x O-Ring
23	34-12932	2	Cylinder Saddle
24	34-12994	2	Hose Clamp
25	34-18888-GR	9	-12 Green - Spiral Band
26	34-18888-OR	15	-12 Orange - Spiral Band
27	34-18888-RD	9	-12 Red - Spiral Band
28	35-12633-0410	1	41" x 1/2" -8 FJIC x -8 FJIC Hose w/ Cordura
29	35-12633-0520	1	52" x 1/2" -8 FJIC x -8 FJIC Hose w/ Cordura
30	35-12633-0540	1	54" x 1/2" -8 FJIC x -8 FJIC Hose w/ Cordurardura
31	35-12633-0680	1	68" x 1/2" -8 FJIC x -8 FJIC Hose w/ Cordura
32	35-30183	6	293" (24.42") x 1/2" -8JIC/-8JIC Hose w/165" Cordura
33	35-31137	2	84" x 1/2" -8JIC/-8JIC Hose w/Cordura
34	35-31192	2	88" x 1/2" -8JIC/-8JIC Hose w/Cordura
35	35-41940	2	Lift Cylinder Steel Line
36	57-20740	2	1/4" Flat Washer
37	57-20744	2	1/2" Washer
38	70-20807	2	3/4" Hex Jam Nut NF

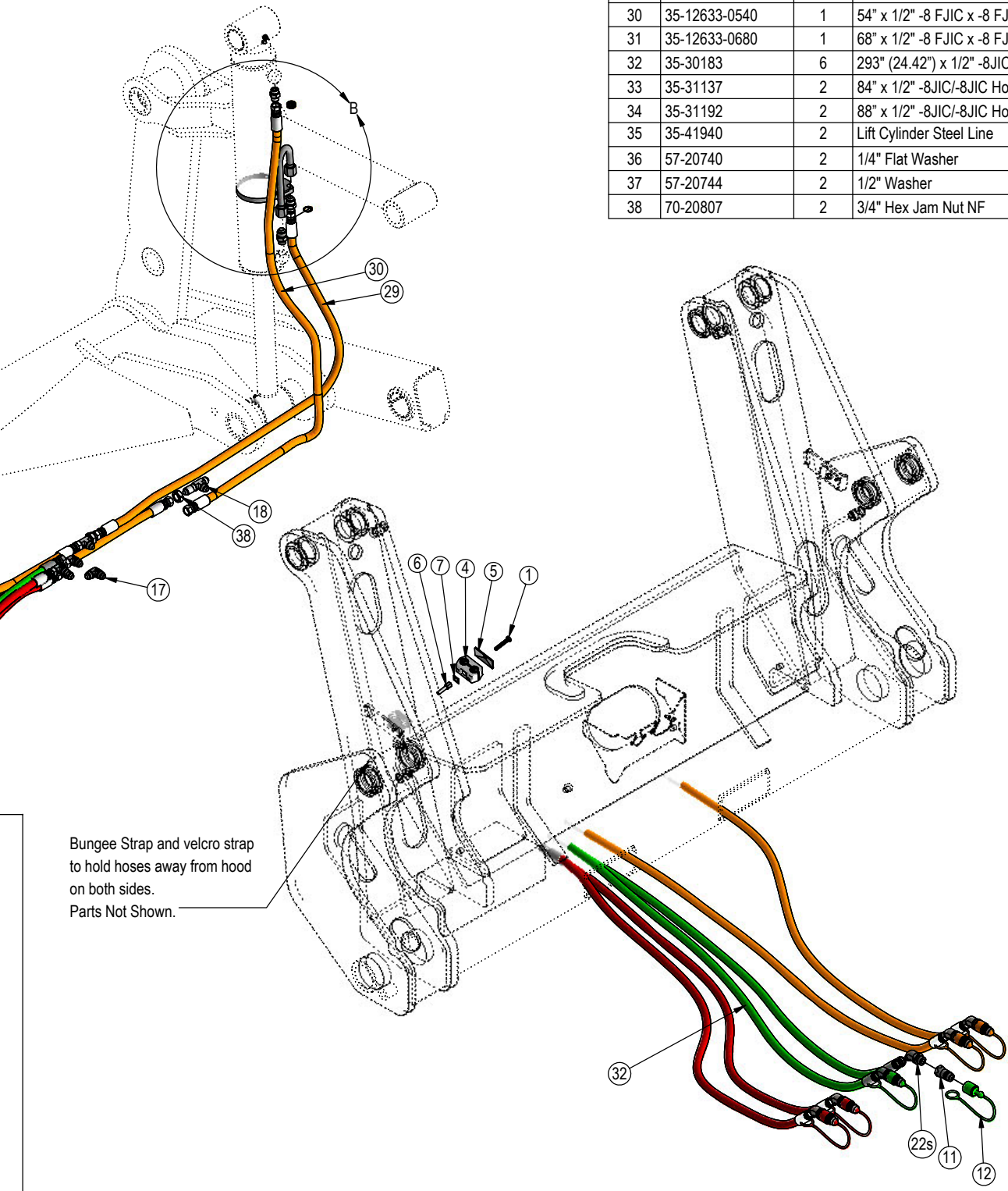

Prior to operating the blade system, all air must be purged from the hydraulic system. Follow the steps below for each function on your blade.

Lift Function:

1. With the lift frame down and blocked, loosen the fittings on both ends of the lift cylinders.
2. Actuate the raise function to supply oil to the rod end of the cylinders.
3. When oil starts to flow from the fittings, stop oil flow, and tighten the fitting on the rod end of the lift cylinders.
4. Continue to flow oil until the system is fully raised and then block the lift frame.
5. Actuate the function in the opposite direction to supply oil to the base end of the lift cylinders.
6. When all air is removed from the lift system, stop oil flow and tighten the fittings on the base end of the lift cylinders.
7. Raise lift system and remove blocks. Cycle up and down 5 more times.
8. Check tractor oil level and fill if necessary.
9. Continue with connecting the blade.

Tilt Function:

Note: Damage will incur if blade stands are down during blade operation.

1. Use a lift or jack to tilt the blade system until the left side is fully up, loosen the fittings on the rod and base end of both tilt cylinders.
2. Actuate the tilt function to extend the right tilt cylinder and supply oil to the base end of the right cylinder and to the rod end of the left cylinder.
3. When oil starts to flow from the fittings, stop oil flow, and tighten the fitting on the base end of the right cylinder and rod end of the left cylinder.
4. Remove the lift or jack.
5. Continue to actuate the tilt function until oil flows out of the remaining open ports.
6. Actuate the tilt function in the opposite direction.
7. When all air is removed from the tilt system, stop oil flow, and tighten the remaining fittings on the cylinders.
8. Cycle both cylinders in and out 5 more times.
9. Check tractor oil level and fill if necessary.

Angle Function:

1. Use a fork lift to angle the blade system until the left side is fully out, loosen the fittings on the rod and base end of the angle cylinders.
2. Actuate the angle function to extend the right angle cylinder and supply oil to the base end of the right cylinder and to the rod end of the left cylinder.
3. When oil starts to flow from the fittings, stop oil flow, and tighten the fitting on the base end of the right cylinder and rod end of the left cylinder.
4. Remove the fork lift.
5. Continue to actuate the angle function until oil flows out of the remaining open ports.
6. Actuate the angle function in the opposite direction.
7. When all air is removed from the angle system, stop oil flow, and tighten the remaining fittings on the cylinders.
8. Cycle both cylinders in and out 5 more times.
9. Check tractor oil level and fill if necessary.

Run the blade through all the functions. If any function does not operate correctly, refer to corresponding section above and re-bleed. If problem still persists, call Grouser Products.

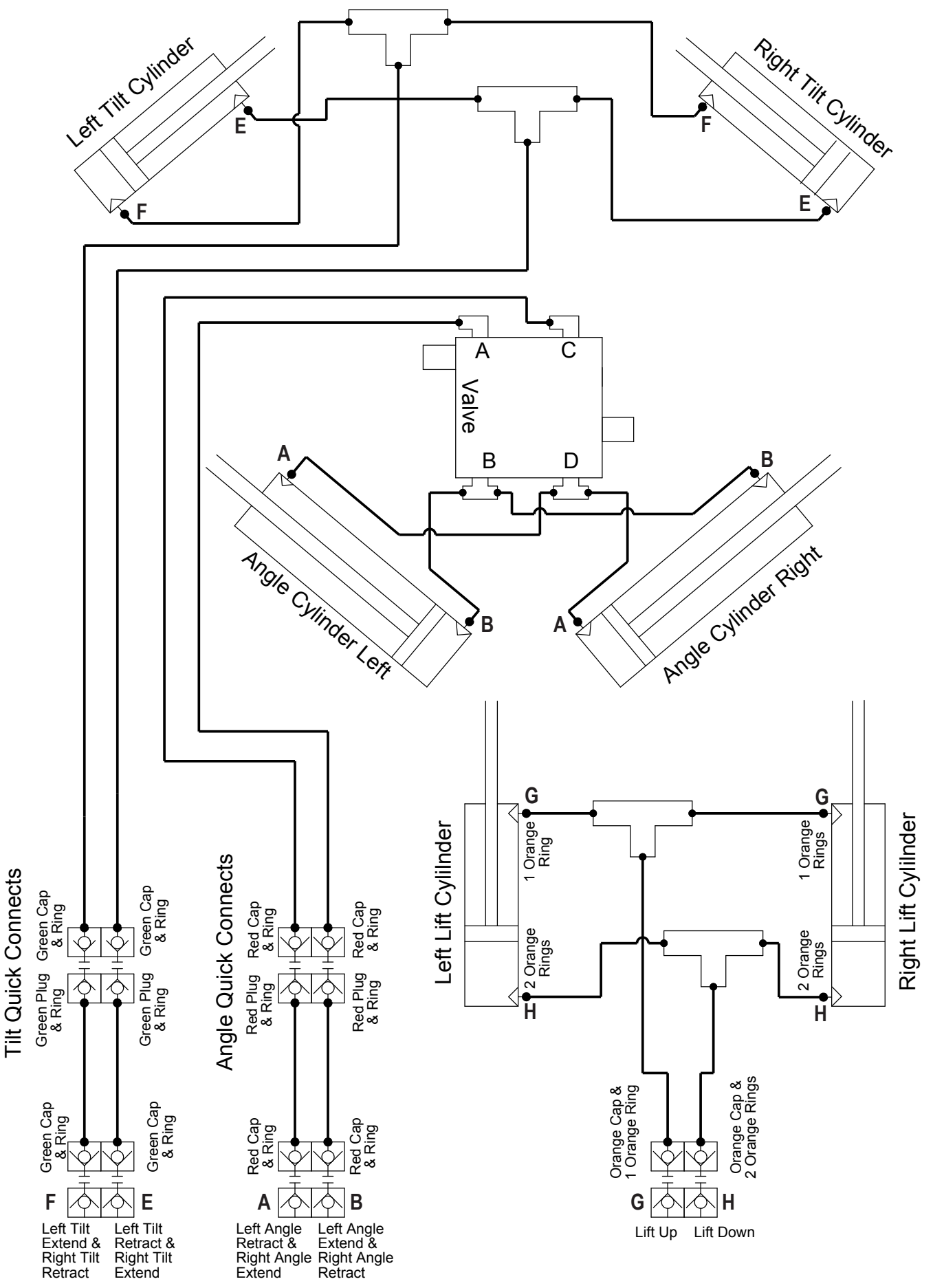

Female Quick Connects At Rear Of Tractor

Before Each Use:

1. Disconnect the mobile half from the parking station and the cap from the fixed half.
2. Check that there is no contamination (salt, sand, dirt, etc.):
 - A. On the pins.
 - B. Inside the cam.
 - C. In the locking mechanism area.
 - D. On the face of the plates and couplings.
3. In case of contamination, remove it with a cloth and/or compressed air.
4. Check that there is still a lubricant/anti-corrosion (grease or silicone - see Note 1):
 - A. On the pins.
 - B. Inside the cam.
 - C. In the locking mechanism area.
5. Connect the mobile and fixed halves together.

Fixed Half

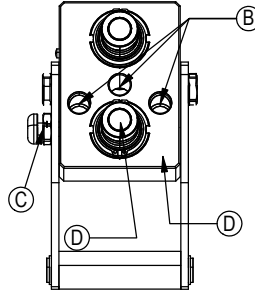

Mobile Half

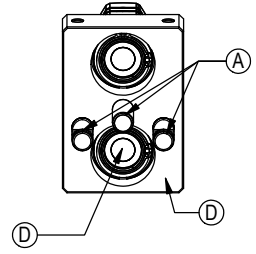

After Each Use:

1. Disconnect the mobile half from the fixed half.
2. Clean all contamination (salt, sand, dirt, etc.) from the following areas:
 - A. On the pins.
 - B. Inside the cam.
 - C. In the locking mechanism area.
 - D. On the face of the plates and couplings.

*Use a cloth or compressed air. It is advised to not use water to clean these surfaces
3. Apply a lubricant/anti-corrosion (grease or silicone - see Note 1):
 - A. On the pins.
 - B. Inside the cam.
 - C. In the locking mechanism area.
4. Connect the cap to the fixed half and the mobile half to the parking station.

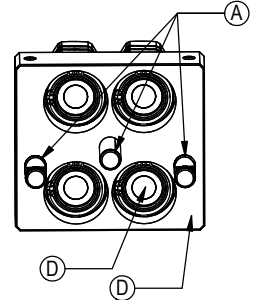
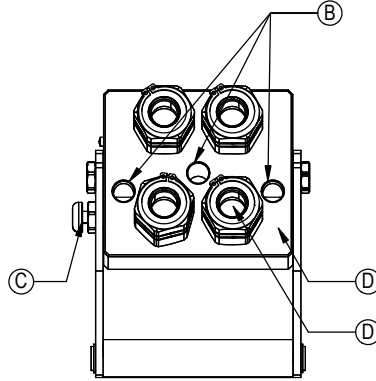

Note 1:

When sand and salt are present, or the plates under go a washdown, a heavy duty silicone spray lubricant should be used to replace grease from the factory. The lubricant should help protect from corrosion without collecting dust and contaminants, and will resist washing off when exposed to water.

Recommended Lubricant Brands:

Fluid Film (Aerosol or Non-Aerosol), LPS-2 Heavy Duty Lubricant, or CRC 3-36.

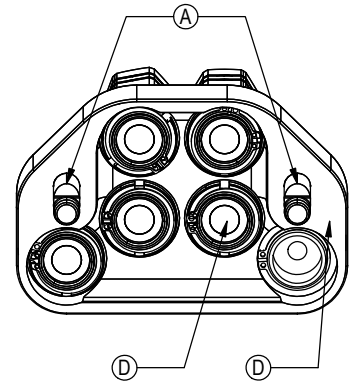
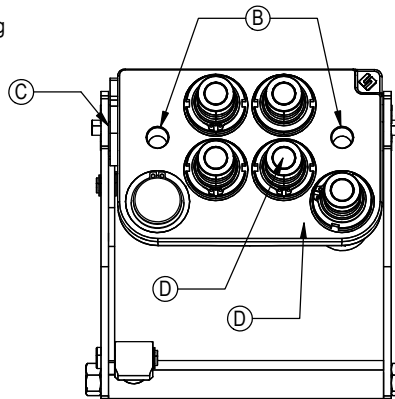

Cleaning The Male Interface Seal:



1. Make sure the coupling is securely fastened into the plate or place in a vice.
2. Using a blunt, non-marring tool, depress the valve face until the seal is exposed. Insert a bent metal wire between the valve face and the body of the coupling. Use caution not to damage or scratch the seal when inserting the wire.
3. Inspect the seal and interior surfaces for contamination.
4. In case of contamination, carefully wipe surfaces with a soft cloth, or use compressed air to blow the contamination out. Do Not press hard on the seal as contamination can scratch the seal surface.
5. Using a non-marring tool, depress the valve face and remove the metal wire. Release the valve to the flush position.

Cleaning The Female Bushing:



1. Make sure the coupling is securely fastened into the plate or place in a vice.
2. Using a non-marring tool, depress the outer ring to expose the bushing. There is no need to expose the valve seal, so stop pressing before the valve is opened.
3. Inspect the interior body and bushing surfaces for contamination.
4. In case of contamination, carefully wipe surfaces with a soft cloth, or use compressed air to blow the contamination out.
5. Release the outer ring so that it returns to the flush position.

Contact Us

As always, if you have any questions about your Dozer or other products made by Grouser, feel free to contact us.

Grouser Products

755 2nd Ave NW - West Fargo, ND 58078

Phone: 1-701-282-7710

Fax: 1-701-282-8131

E-mail: info@grouser.com

Website: www.grouser.com

Improvements

Grouser Products Inc. is continually striving to improve its products. We reserve the right to change prices, specification, or equipment at any time without notice. We also reserve the right to make improvements or changes when it becomes practical and possible to do so without incurring any obligation to make changes or additions to the equipment sold previously.

Warranty

Grouser Products warrants to the original purchaser of each item that the product be free from defects in material and workmanship under normal use and service for a period of two years. If such equipment is found to be defective within two years, it is the obligation of Grouser Products under this warranty to repair or replace (exclusive of the cost of labor and transportation), any equipment or parts, in the judgment of Grouser Products to be defective in material or workmanship.

All equipment or parts claimed to be defective in material or workmanship must be made available for inspection at the place of business of a dealer authorized to handle the equipment covered by this warranty, or, upon request by Grouser Products, shipped to the Grouser Products factory in West Fargo, North Dakota. Grouser Products shall have no obligation to bear the cost of labor or transportation in connection with replacement or repair of any such defective parts in the setup process.

This warranty covers only defects in material and workmanship. It does not cover depreciation or damage caused by normal wear, accident, improper assembly, improper adjustments, improper maintenance including lack of proper lubrication, or improper use. Therefore, Grouser Products liability under this warranty shall not be effective or actionable unless the equipment is assembled, maintained and operated in accordance with the operating instructions accompanying the equipment. Grouser Products shall have no liability if the equipment has been altered or reworked without the written authorization of Grouser Products.

Grouser Products' parts, which are furnished under this warranty and properly installed, shall be warranted to the same extent as the original parts under this warranty if, and only if, such parts are found to be defective within the original warranty period covering the original equipment.

