



Case Steiger

Ag Pro Undercarriage

Installation Instructions

For Models:

Case Steiger Quad Tier 4B: 470, 500, 540, 580, 620

Purchase Date
Serial Number
Model Number
Tractor Model
Dealer

To The Owner

This manual contains information concerning the installation of the undercarriage. You have purchased dependable, long lasting equipment, but only by proper care and operation can you expect to receive the performance and long service built into our products. Please have all operators read this manual carefully and keep the manual available for ready reference. If you have any questions or concerns, contact Grouser Products.

Caution:

- Always use caution when working around any equipment.
- Always wear safety glasses.
- Follow tractor manufacturer's safety guidelines when installing this product.
- Use paint where necessary to prevent rust.
- Do not modify or permit anyone else to modify or alter the equipment and its components without first consulting Grouser Products.



Serial Number Location

Note:

- When installing hardware, only finger tighten until all hardware is in place.
- A full diagram of the assembly with the full list of parts is on pages 6-7.
- Unstrap and remove any components that are attached for shipping.
- Read all instructions prior to performing installation.
- Tractor frame not shown in some diagrams for clarity.

Installation

1. If applicable, remove front weights, weight bracket, toolboxes and tow cable holder. If tow cable kit was purchased from Grouser, the tow cable will be reinstalled in a later step.
2. Remove brackets from undercarriage to make room for installing undercarriage on the tractor and unscrew vertical 1" bolts at rear of undercarriage.
3. Position undercarriage under tractor and center on tractor frame.

NOTE: When lifting undercarriage, watch for potential pinching of hoses or any other components to prevent damage.

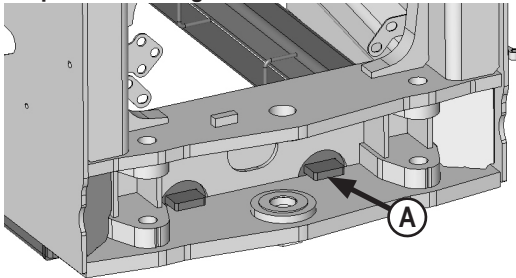

4. Lift undercarriage and set top rear plates on tractor cross member (A). Push undercarriage back until vertical push plates are firmly against cross member.

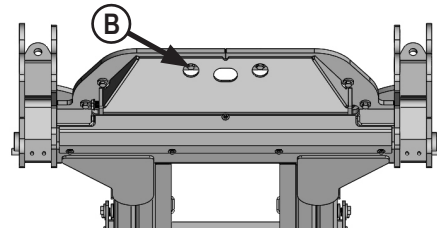

5. Lift front of undercarriage and install 8 - 20mm x 90mm bolts, 8 - 3/4" ID x .375" thick washers, 8 - 3/4" flat washers and 8 - 20mm nuts in front vertical slots (B).

NOTE: See Page 6-7 for proper orientation of hardware.

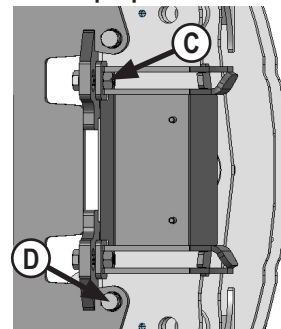

6. At rear of undercarriage and pivot area of tractor, hook rear clamp bracket to tractor frame and attach to rear of undercarriage with 2 - 1" x 3" bolts, 2 - 1" flat washers, and 2 - 1" nuts. The nut will fit between plates on bracket (C).
7. Center rear clamp bracket on undercarriage and tractor. Torque 1" bolts on the bracket to 500 ft-lbs (C). Gap between the bracket and the undercarriage is allowed.

8. Torque rear vertical 1" bolts to 100 ft-lbs (D).
9. Torque front vertical 20mm bolts to 432 ft-lbs (B).

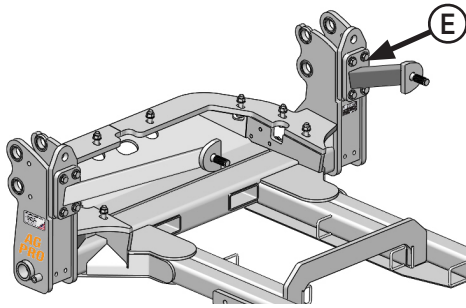

10. Attach front upper support arms to undercarriage with 8 - 3/4" x 2-1/2" bolts and 8 - 3/4" hardened flat washers (E).

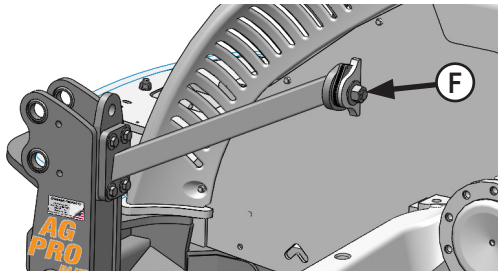

11. Attach front upper support arms to tractor with 2 - 1-1/4" flat washers and 2 - 1-1/4" nuts (F).

NOTE: Add shims between support arm and tractor frame to reduce any gap if necessary. Use shims until there is a gap less than 1/16".

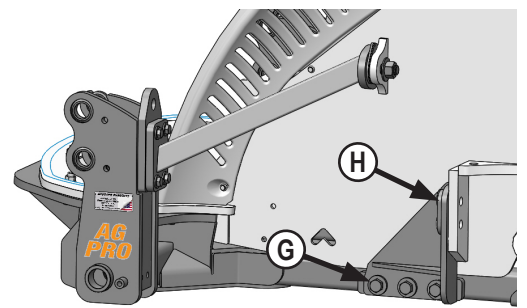

12. Remove 24mm bolts and spacers from front axle on both sides of tractor. Discard spacers.
13. Attach yoke brackets to undercarriage with 6 - 1" x 2-1/2" bolts and 6 - 1" ID x .375" thick washers (G).
14. Dip previously removed 24mm bolts in W30 oil and attach yoke brackets to tractor frame with 4 - 24mm bolts and 4 - 1" flat heavy washers (H).
15. Torque upper support arm 3/4" bolts to 380 ft-lbs (E).
16. Torque upper support arm 1-1/4" nuts to 1,105 ft-lbs (F).
17. Torque original 24mm bolts to 555 ft-lbs (H).
18. Torque yoke bracket 1" bolts to 903 ft-lbs (G).

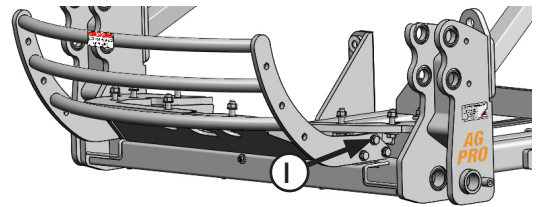

19. Install grill guard to front of undercarriage with 6 - 3/4" x 1-3/4" bolts and 6 - 3/4" flat washers (I).
20. Torque 3/4" bolts to 257 ft-lbs (I).

NOTE: If applicable, refer to Page 5 to attach front of tow cable.

Hose Routing

1. Route hoses through hose loops on undercarriage and through large loop at the rear of the undercarriage.

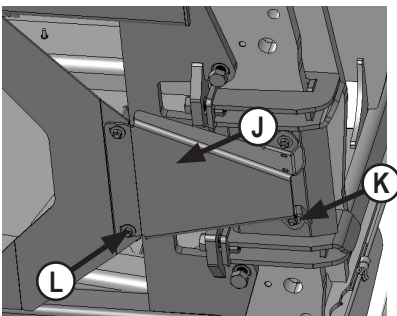

2. Lift bottom cover plate (J) into place with hoses between cover plate and rear clamp bracket.
3. Attach bottom cover plate to rear clamp bracket with 2 - 1/2" flat washers, and 2 - 1/2" nuts (K).
4. Attach bottom cover plate to rear of undercarriage with 2 - 1/2" x 1-1/4" carriage bolts, 2 - 1/2" flat washers, and 2 - 1/2" nuts (L). Install bolts from top.

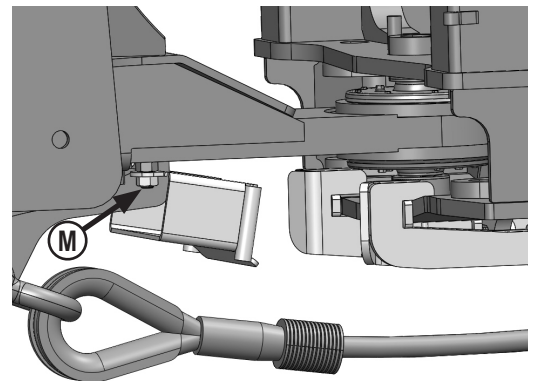

5. Place rear hose routing bracket and hoses over 2 - 20mm bolts located on rear tractor frame in front of drawbar. Attach with 2 - 20mm nuts (M). Ensure lip of bracket is facing towards front of tractor.
6. Torque the 20mm nuts to 432 ft-lbs (M).
7. Use Zip Ties to group equal amounts of hoses on left and right side of hose routing bracket

NOTE: Refer to diagram at the bottom of page if clarification is needed for Step #8-13.

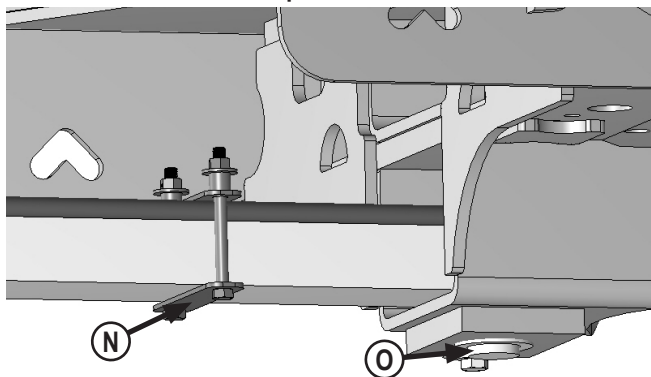

8. Position hoses on top of drawbar and secure with 4- hose holding plates, 4 - 1/2" x 5-1/2" or 6" bolts, and 4 - 1/2" nuts.
9. Place front holding plates (N) 12" from center of drawbar pin at front of drawbar (O).

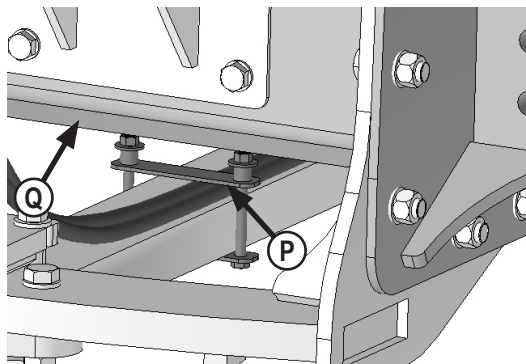

10. Place rear holding plates (P) half-way between rear axle and rear tractor frame (Q).
11. Turn and articulate tractor to provide slack in hoses at pivot point.

NOTE: When tightening the 1/2" nuts, do not crush the hoses.

12. Tighten hardware on drawbar hose holding plates until plates are firmly against hoses without deforming hoses. Use 3/4" spacers and 1/2" washers on top plate if needed to provide enough thread to tighten.
13. Insert couplers in open SCV's at back of tractor.

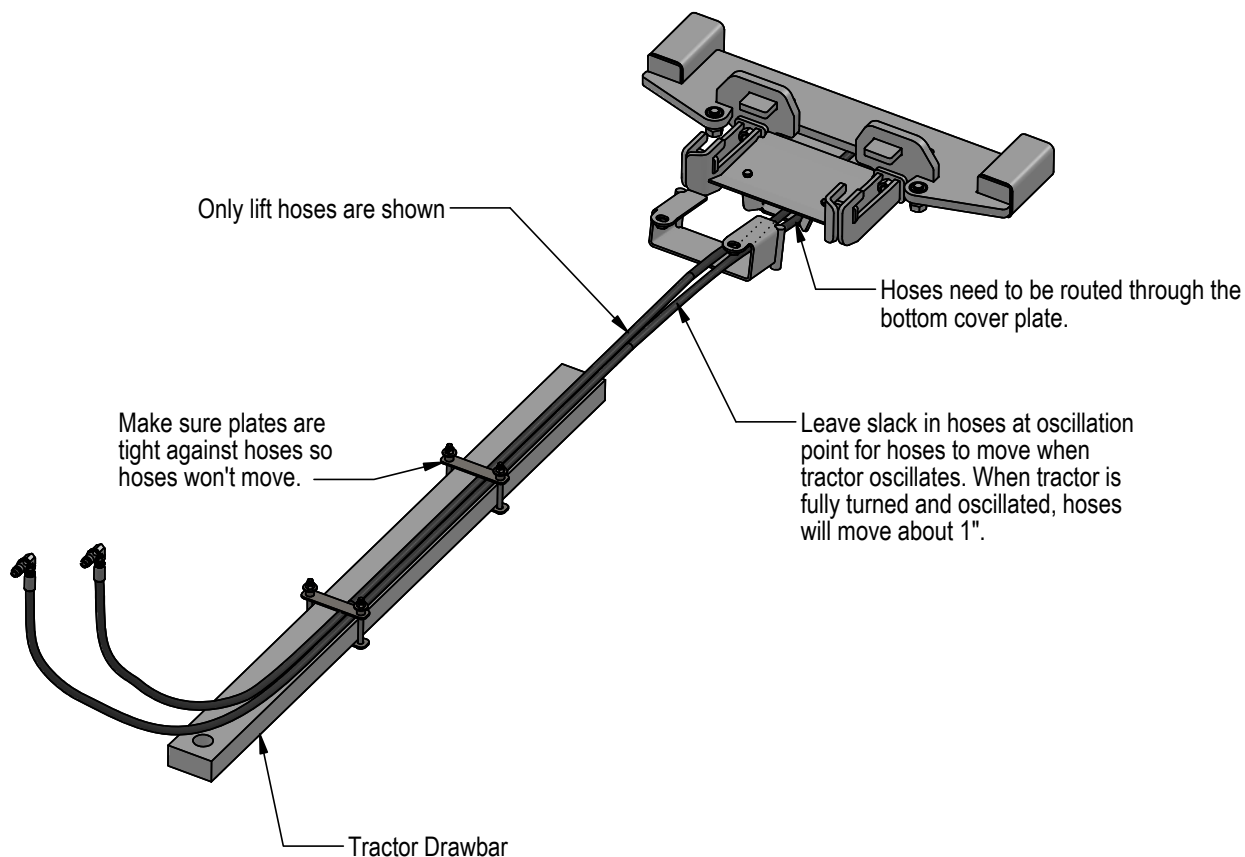

Assembling Lift Components



1. Refer to the Blade Owner's Manual & Parts Book for instructions on how to assemble the lift components.
2. When installing hydraulics on top arms, group hoses together with velcro strap and attach to bottom of top arm with a 3/8" x 1" bolt, spacer, and 3/8" flange nut in the square hole (R).

Maintenance

1. After first 8 hours of use, re-torque all bolts.
2. Check all fasteners regularly to ensure proper operation of equipment.
3. Inspect all equipment for existing or potential damages every 10 hours or less.

Tow Cable Support Bracket Assembly

NOTE: Kit is required if tractor has a tow cable.

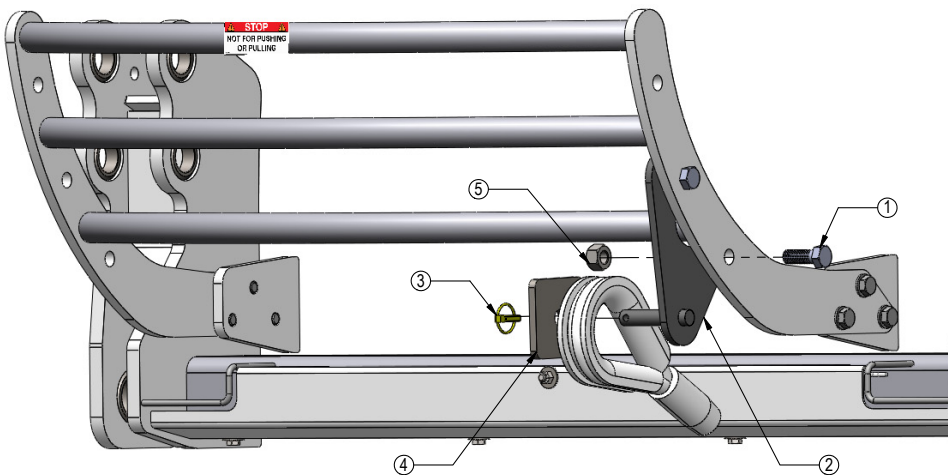

Ag Pro Plus - Tow Cable Support Bracket Assy - 18-19095-A

Item No.	Qty.	Part No.	Description
1	2	16-20540	7/8" x 2-1/2" Hex Bolt Gr 8 NC
2	1	18-19095	Tow Cable Support Bracket
3	1	43-16764	7/16" x 1-3/4" Lynch Pin
4	1	44-15585	Tow Cable Holding Plate
5	2	70-20598	7/8" Hex Nut Gr 8 NC

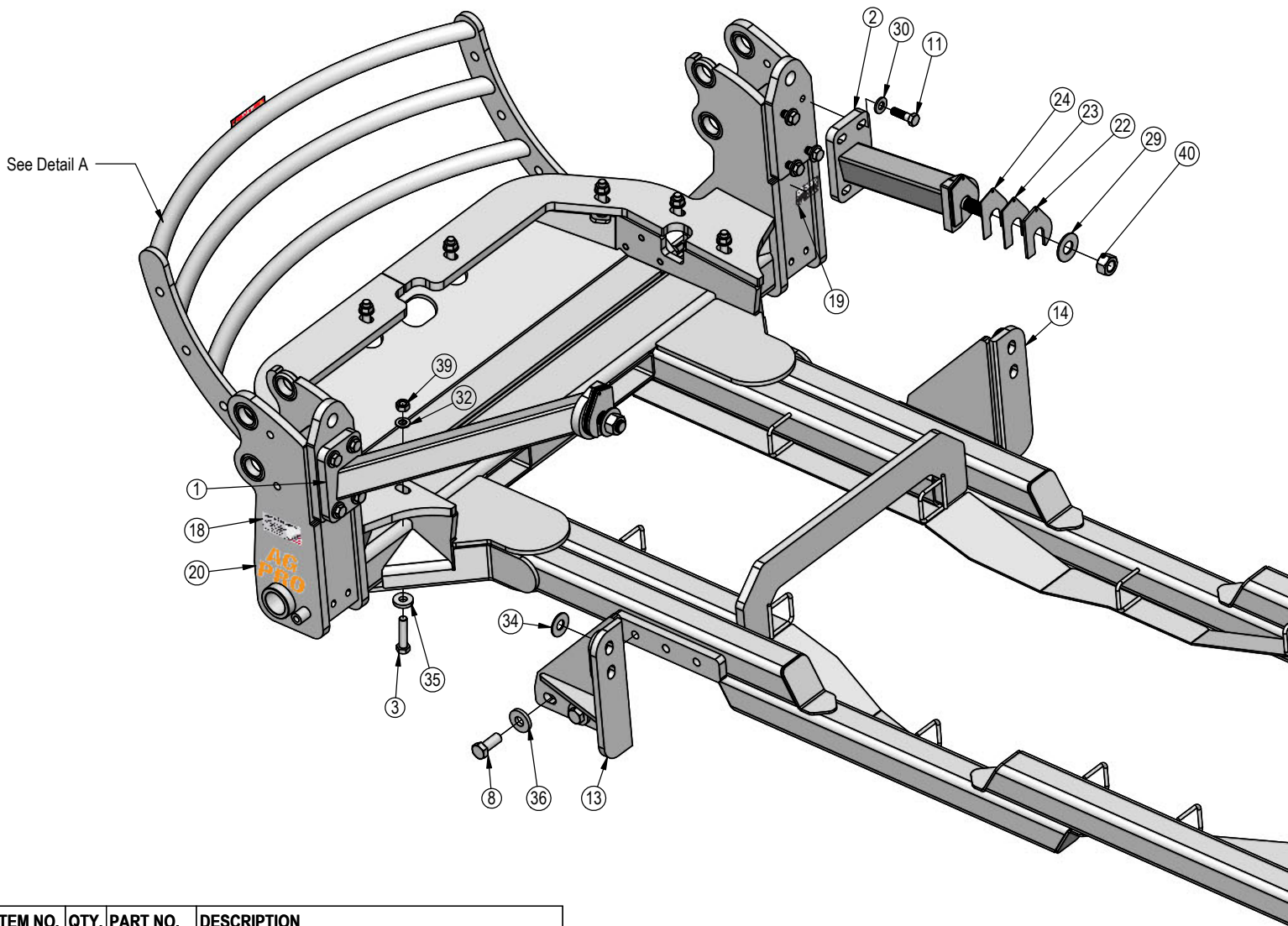

ITEM NO.	QTY.	PART NO.	DESCRIPTION
1	1	11-18716-L	Support Arm, Quad (T4B)
2	1	11-18716-R	Support Arm, Quad (T4B)
3	8	16-1510	20mm x 2.5mm x 90mm Hex Bolt Gr 10.9
4	4	16-20124	1/2" x 1" Hex Bolt Gr.5 NC
5	4	16-20139	1/2" x 5-1/2" Hex Bolt Gr 5 NC
6	6	16-20217	3/4" x 1-3/4" Hex Bolt Gr 5 NC
7	2	16-20558	1" x 2" Hex Bolt Gr 8 NC
8	6	16-20560	1" x 2-1/2" Hex Bolt Gr 8 NC
9	2	16-20562	1" x 3" Hex Bolt Gr 8 NC
10	2	16-21125	1/2" x 1-1/4" Carriage Bolt Gr 5 NC
11	8	16-22220	3/4" x 2-1/2" Hex Bolt Gr 8 NC
12	1	18-18059	Grill Guard Weld
13	1	18-18706-L	Bracket, Yoke
14	1	18-18706-R	Bracket, Yoke
15	1	18-40518	Hose Routing Bracket
16	1	18-42070	CNH Large Frame Clamp Bracket
17	1	27-18882	Not For Pushing or Pulling Decal
18	1	27-18887	Grouser Name Plate Decal
19	1	NA	Grouser Dozer Metal Serial Tag
20	2	27-40983	Ag Pro Decal
21	4	44-17245	Plate

DETAIL B
SCALE 1:8

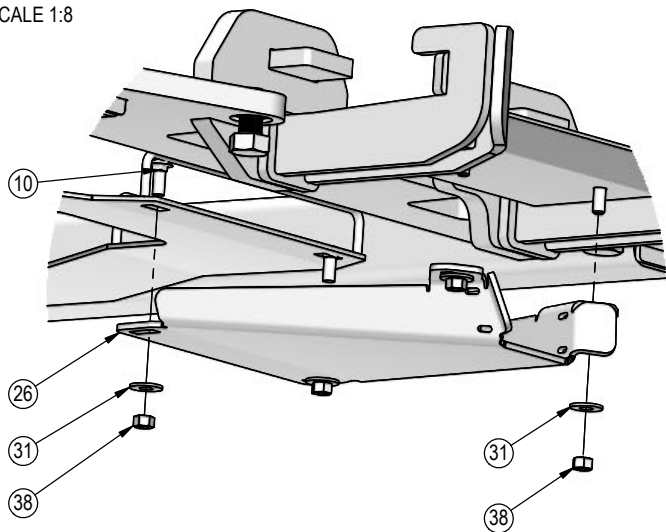

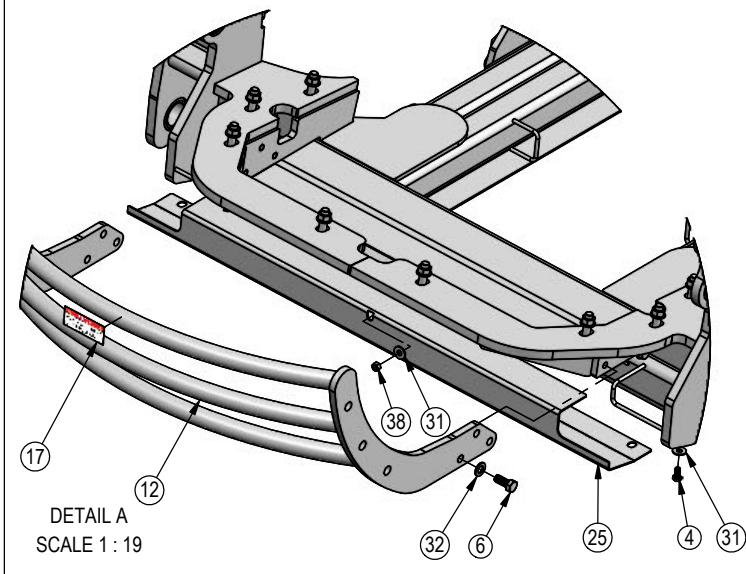

ITEM NO.	QTY.	PART NO.	DESCRIPTION
22	4	44-18721	Support Arm Shim, .25"
23	4	44-18722	Support Arm Shim, .125"
24	4	44-18723	Support Arm Shim, .063"
25	1	44-40504	Plate, Cover
26	1	44-42240	Plate, Bottom Cover
27	4	53-15528	Round Tube
28	1	54-42230	CNH Wide Frame Undercarriage Weld
29	2	57-11671	1-1/4" Flat Washer
30	8	57-19088	3/4" Hardened HD Flat Washer
31	13	57-20744	1/2" Washer
32	14	57-20757	3/4" Flat Washer - 1-1/2" OD
33	2	57-20759	1" Flat Washer - 2" OD
34	4	57-20819	1" Flat Washer Heavy Duty Gr 8
35	8	57-3680	3/4" ID x 2.00 OD x .375" Heavy Washer
36	6	57-3682	1.00" ID x 2.50" OD x .375" Heavy Washer
37	2	70-20599	1" Hex Nut Gr 8 NC
38	9	70-20604	1/2" Hex Center Lock Nut Gr 2 NC
39	10	70-20872-10	20mm Hex Nut 2.5 Pitch Class 10
40	2	70-20981	1-1/4" Hex Nut Gr 5 NC
41	4	70-20140	1/2" x 6" Hex Bolt Gr 5 NC

Item #41 - Used only with 12-20 & 3-5 Dozer Hydraulics in place of Item #5

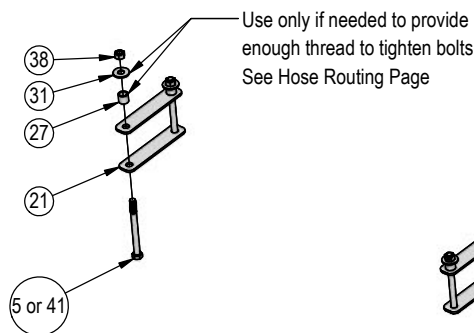
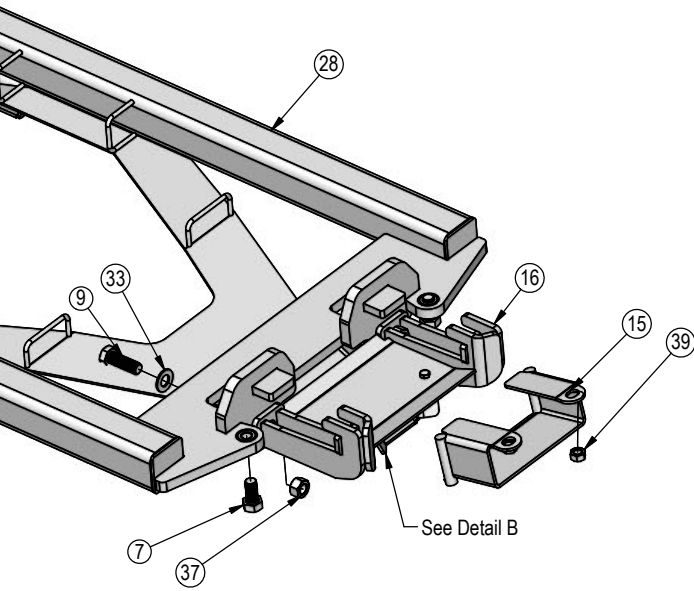

Improvements

Grouser Products Inc. is continually striving to improve its products. We reserve the right to change prices, specification, or equipment at any time without notice. We also reserve the right to make improvements or changes when it becomes practical and possible to do so without incurring any obligation to make changes or additions to the equipment sold previously.

Warranty

Grouser Products warrants to the original purchaser of each item that the product be free from defects in material and workmanship under normal use and service for a period of **two (2) years for Agriculture Series Blades and one (1) year for Heavy Duty Series from date of original retail delivery.**

The obligation of the consumer under this warranty:

1. To read the operators manual and to operate, lubricate, maintain and store equipment in accordance with the instructions listed in the operators manual.
2. To inspect equipment and if any part needs repair or replacement when continued use would cause damage or wear to other parts or safety.
3. All equipment or parts claimed to be defective in material or workmanship must be made available for inspection at the place of business of a dealer authorized to handle the equipment covered by this warranty, or, upon request by Grouser Products, shipped to the Grouser Products factory in West Fargo, North Dakota.

The obligation of the dealer under this warranty:

1. Complete warranty registration form and submit within 30 days of sale.
2. Contact Grouser Products for authorization prior to performing any warranty repairs or part replacement.
3. Complete warranty request form and submit with photos and supporting documentation.

The obligation of Grouser Products under this warranty:

1. Repair or replace, any equipment or parts, in the judgment of Grouser Products to be defective in material or workmanship.
2. Grouser Products will cover the cost of parts and ground shipping at dealer invoice only.
3. Grouser Products shall have no obligation to bear the cost of labor or transportation in connection with replacement or repair of any such defective parts.

This warranty does not cover:

1. Depreciation or damage caused by normal wear, accident, improper assembly, improper adjustments.
2. Improper maintenance including lack of proper lubrication, or improper use. Including loose bolts, nuts, or fitting due to over tightening or vibration after 20 hours of operation.
3. Repairs or alterations without authorization from a Grouser Products representative.
4. Grouser Products shall have no liability if the equipment has been altered or reworked without the written authorization of Grouser Products.

Grouser Products' parts, which are furnished under this warranty and properly installed, shall be warranted to the same extent as the original parts under this warranty if, and only if, such parts are found to be defective within the original warranty period covering the original equipment.

NO EMPLOYEE OR REPRESENTATIVE OF GROUSER PRODUCTS IS AUTHORIZED TO CHANGE THE WARRANTY IN ANY WAY OR GRANT ANY OTHER WARRANTY.

Contact Us

As always, if you have any questions about your system or other products made by Grouser, feel free to contact us.



755 2nd Ave NW - West Fargo, ND 58078
+1 701-282-7710 | info@grouser.com
www.grouser.com