

Bar Track Parts

- Crossbar track has 2" wide bars.
- Contractor grade, heavy duty components.
- Large 1-1/4" hardened, field replaceable bushings.
- Larger traction bars for improved track-to-tire grip.
- 2 built in traction bars.
- Patented open side plate for excellent clean out in the pivot area.
- Improved side wall design for today's heavy duty tires.
- Built-in length adjustment.
- Run loose design.
- Self cleaning.
- Reduces tire wear in abrasive conditions.
- Adds counterweight.
- Provides tire protection.
- May be installed in 30 minutes or removed in 10 minutes.
- Field serviceable.
- Rebuildable.
- Reduces ground pressure by as much as 50%.

Item	Note	Model #	Description	Wt #
1		850-2W	8.5" Welded Pad (3/4" Bars)	10
1,2,3,4,5	A	850-2WC	8.5" Welded Pad Complete	14
1		105-3FW	10.5" Welded Pad (1" Bars)	16
1,2,3,4,5	A	105-3FWC	10.5" Welded Pad Complete (1" Bars)	21
1		115-2FW	11.5" Welded Pad (3/4" Bars)	13
1,2,3,4,5	A	115-2FWC	11.5" Welded Pad Complete	18
1		115-3FW	11.5" Welded Pad (1" Bars)	16
1,2,3,4,5	A	115-3FWC	11.5" Welded Pad Complete (1" Bars)	21
1		132F	13.25" Pad (for 10.00 Tires)	21
1,2,3,4,5	A,C	132FC	13.25" Pad Complete	26
1	D	132FLP	13.25" Low Profile	20
1,2,3,4,5	A,D	132FLPC	13.25" Low Profile Complete	25
1		147F	14.75" Pad (for 12.00 Tires)	23
1,2,3,4,5	A,C	147FC	14.75" Pad Complete	27
1		155F	15.5" Pad	25
1,2,3,4,5	A	155FC	15.5" Pad Complete	30
1		160F	16.00" Pad (for 14.00 Tires)	23
1,2,3,4,5	A,C	160FC	16.00" Pad Complete	28
1		170F	17.00" Pad (for 14.00 Tires)	25
1,2,3,4,5	A,C	170FC	17.00" Pad Complete	30
1		175F	17.50" Pad (for 33-15.5 Tires)	25
1,2,3,4,5	A	175FC	17.50" Pad Complete	30

Item	Model #	Description	Wt #
3	1297	C Link (7/8" holes) Minimum Order 4	1.26
3	7510	D Link (1" holes) Minimum Order 4	1.22
3	7512F	E-F Link (1 1/4" holes) Minimum Order 4	1.53
4	4817	C Bushing 7/8" (O.D.) Minimum Order 12	0.09
4	8863	D Bushing 1" (O.D.) Minimum Order 12	0.12
2,4,5	8863-K	D Bushing 1" Kit Minimum Order 12	0.31
4	8864	E-F Bushing 1 1/4" (O.D.) Minimum Order 12	0.20
2,4,5	8864-K	E/F Bushing 1 1/4 Kit Minimum Order 12	0.39
2	8865	C,D,E,F Nut 1/2" Lock Nut Minimum Order 24	0.04
5	8866	C,D,E,F Carriage Bolt 1/2"x1-7/8" Minimum Order 24	0.15
6	1586	Standard Track Installation Tool	3.52
7	4818	Standard Strap	0.55
8	11350	Optional Track Installation Tool	14.53



Optional Track Installation Tool

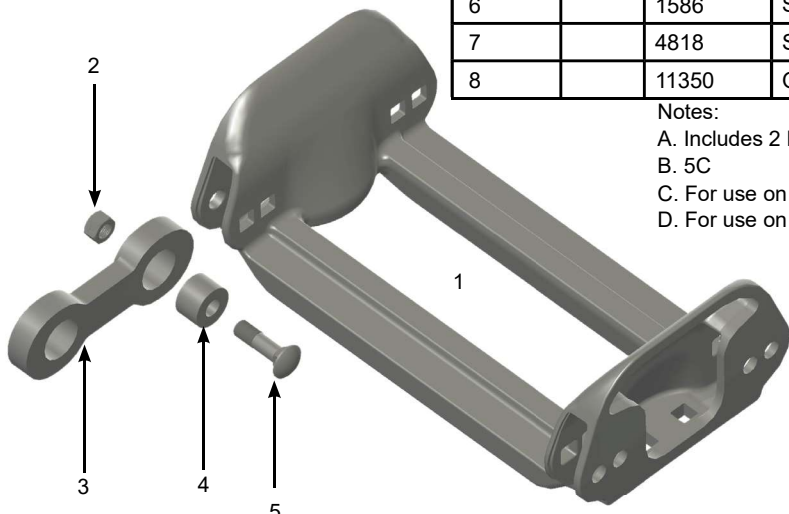

Notes:

A. Includes 2 Links, 4 Nuts, 4 Bolts, 4 Bushings

B. 5C

C. For use on E or F track only.

D. For use on machines with limited clearances.

