



Fendt 1000 Vario & Challenger 1000 FH440 Undercarriage Installation Instructions

For Models Without Factory Three-Point Linkage:

Fendt 1000 Vario: 1038, 1042, 1046, 1050

Challenger 1000: 1038, 1042, 1046, 1050

Purchase Date
Serial Number
Model Number
Tractor Model
Dealer

To The Owner

This manual contains information concerning the installation of the undercarriage. You have purchased dependable, long lasting equipment, but only by proper care and operation can you expect to receive the performance and long service built into our products. Please have all operators read this manual carefully and keep the manual available for ready reference. If you have any questions or concerns, contact Grouser Products.

Caution:

- Always use caution when working around any equipment.
- Always wear safety glasses.
- Follow tractor manufacturer's safety guidelines when installing this product.
- Use paint where necessary to prevent rust.
- Do not modify or permit anyone else to modify or alter the equipment and its components without first consulting Grouser Products.

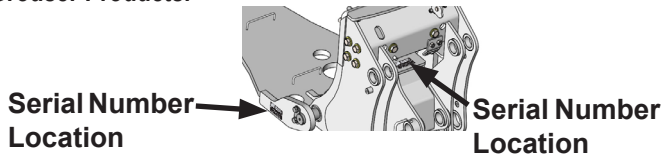

Note:

- When installing hardware, only finger tighten until all hardware is in place.
- A full diagram of the assembly with the full list of parts is on pages 6-7.
- Unstrap and remove any components that are attached for shipping.
- Read all instructions prior to performing installation.



To ensure the safety of those working under and around the machine, apply parking brake, remove key from ignition, and block tires before working on the machine.

Pre-Installation

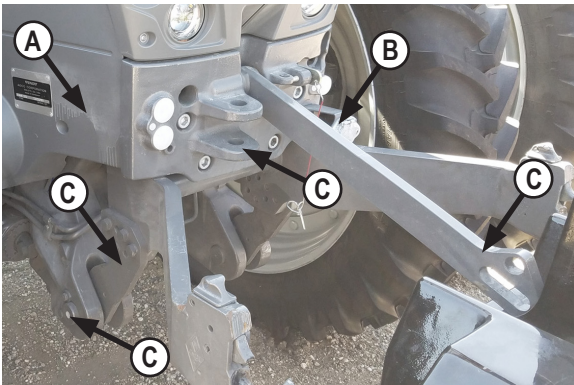

1. Remove the side shields (A).
2. Unplug and remove electrical socket (B) from front of tractor. It will be reinstalled in Step #29. The bracket can stay on front plate.
3. Remove front weights, front rigid arms and brackets, bottom pins and retaining hardware, top link and front plate (C).

NOTE: The threaded hole on bottom pin is for installing a 10mm x 1.5mm bolt to aid in pulling out pin.

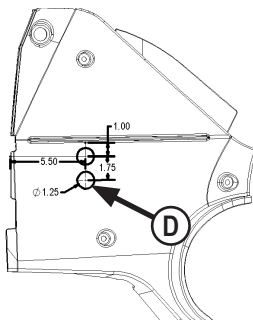

4. If tractor has switches in front plate, remove left side shield. Measure 5.50" from side, 1.00" down from groove and mark first hole. Mark second hole 1.75" down from first hole. Drill 2 - 1.25" diameter holes (D).

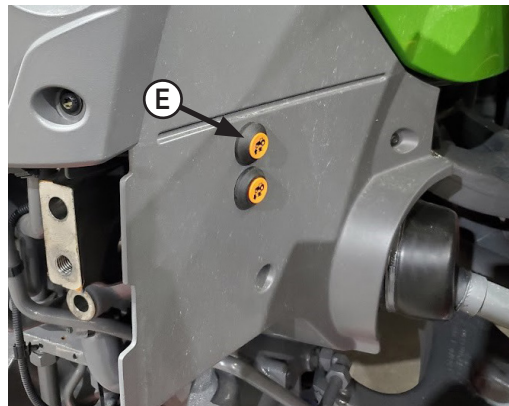

5. Install switches in new holes in left side shield (E).

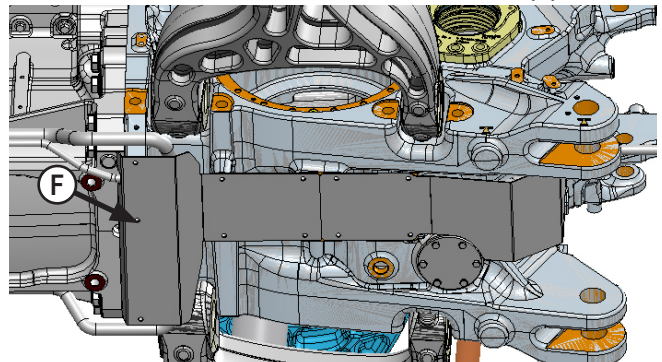

6. Remove rear shield from underneath front of tractor (F).

Installation

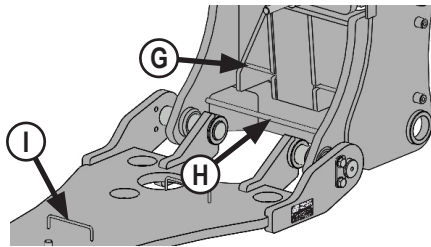

NOTE: If hoses were factory installed on undercarriage, proceed to Step #9.

7. Route hoses from front of undercarriage under first set of bars (G) and then over bottom bar (H) on undercarriage.
8. Continue to route hoses through hose loops on front support (I).

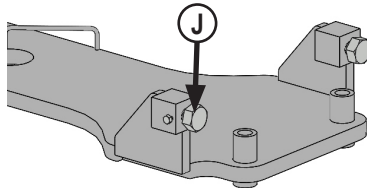

9. Install 2 - 1" x 2" bolts in threaded blocks at rear of support (J). Turn bolts all the way in for installation. The bolts will be adjusted in Step #24.
10. Center front support under tractor.

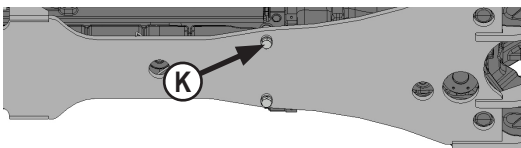

NOTE: When lifting front support, watch for potential pinching of hoses or any other components to prevent damage.

11. Raise front support until ears line up with ears on tractor frame.
12. Install 2 - 20mm x 120mm bolts with 2 - .81" ID washers through front vertical standoffs and into bottom of engine casting (K). Make sure support is loose and not touching bottom of engine.

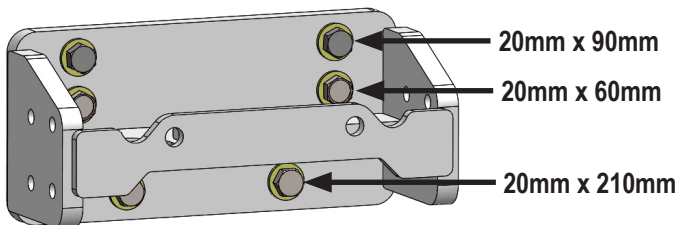

13. Install 2 - 20mm x 90mm bolts with 2 - .81" ID washers through top holes in front master plate bracket and tractor front nose casting.
14. Install 2 - 20mm x 60mm bolts with 2 - .81" ID washers through second row of holes in front master plate bracket and tractor front nose casting.
15. Install 2 - 20mm x 210mm bolts, 2 - .81" ID washers, and 2 - standoffs through bottom holes in front master plate bracket and tractor front nose casting. The standoffs fit between front master plate bracket and tractor front nose casting.

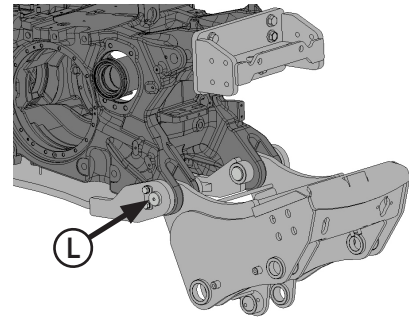

16. Install new pins through outer front ears of front support, tractor frame and undercarriage mount. Secure with 4 - 14mm x 25mm bolts, 4 - 14mm flat washers, and 2 - pin retainer plates (L).

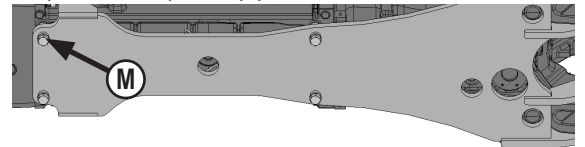

17. Install 2 - 20mm x 120mm bolts with 2 - .81" ID washers through rear vertical standoffs and into bottom of engine casting (M).

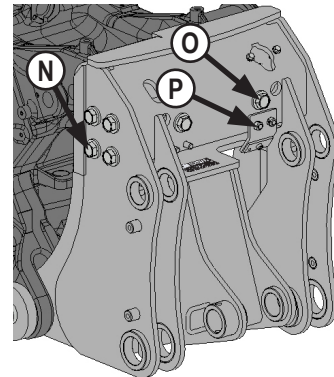

18. Rotate front undercarriage mount into position and install 4 - 20mm x 50mm bolts with 4 - .81" ID washers through side holes on undercarriage mount and front master plate bracket (N).
19. Install 2 - 20mm x 60mm bolts, 4 - .81" ID washers and 2 - 20mm nuts in front holes on undercarriage mount and front master plate bracket (O).
20. Remove hose clamp brackets (P) from front of undercarriage mount to gain access to torque bottom front bolts.

NOTE: The Grouser FH-440 lift system needs to be in lowered position to torque front bolts.

21. Torque front 20mm bolts from Step # 13-15 to 432 ft-lbs.
22. Torque front 20mm bolts (O) from Step # 19 to 432 ft-lbs.
23. Torque side 20mm bolts (N) to 432 ft-lbs.

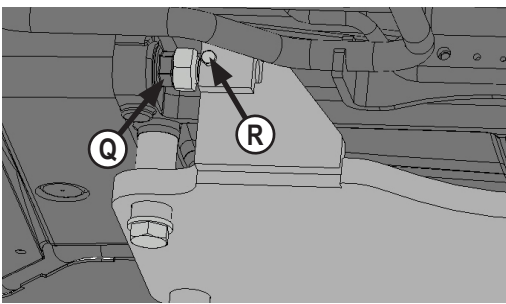

24. Evenly unscrew 1" bolts at rear of front support until they are tight against engine casting bolt heads (Q). Torque 1" bolts to 90-95 ft-lbs.
25. Install 2 - 5/16" x 3/4" bolts into blocks at rear of front support to lock 1" x 2" bolts (R). Torque 5/16" bolts to 19 ft-lbs.
26. Torque vertical 20mm bolts to 432 ft-lbs (K & M).
27. Torque 14mm retaining bolts for ear pins at front of support to 103 ft-lbs (L).

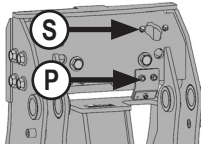

28. Reattach front electrical socket with 2 - 5/16" x 1-1/4" bolts, 2 - 1/4" washers, and 2 - 5/16" nyloc nuts to top of undercarriage mount (S).
29. Reconnect electrical socket wire connection to tractor side wire harness.
30. Reattach hose clamp bracket (P) that was removed in Step #20.

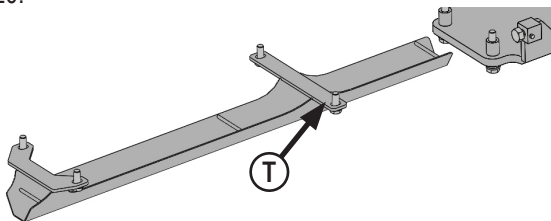

31. Position hose channel on floor under tractor behind front support (T).

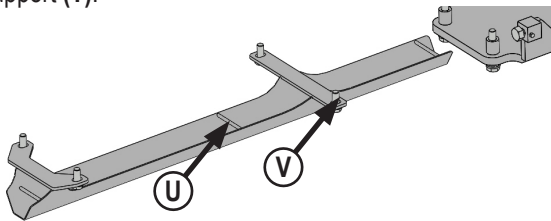

32. Route hoses through hose channel. Keep hoses below bars on hose channel (U).
33. Raise hose channel and attach to tractor with 4 - 20mm x 50mm bolts and 4 - 0.81" ID washers (V).
34. Torque 20mm bolts to 432 ft-lbs.



35. Route hoses to back of tractor. Stay above drawbar and away from PTO (W).

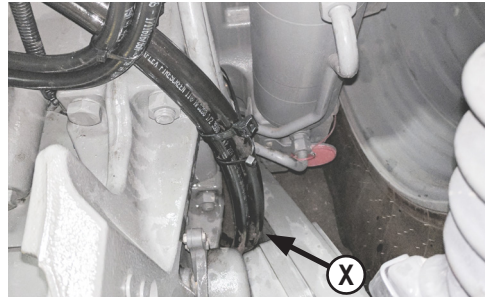

36. Route hoses up through opening between slide rails and 3-point lower arm on each side (X). Quantity of hoses can vary depending on which blade system is installed.

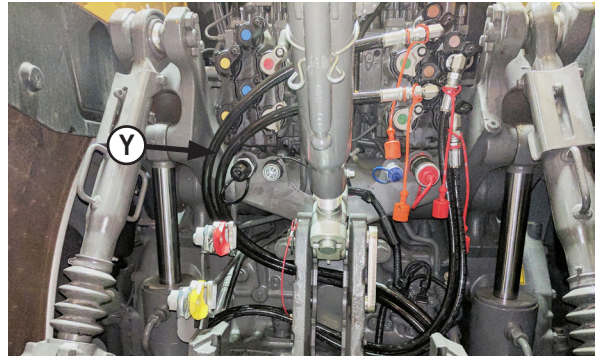

37. Route hoses as shown (Y).
38. Plug the hoses into open SCV's at rear of tractor.

Note: The installer is responsible to route hoses in a practical manner, to protect the hoses around sharp corners and moving objects, and secure hoses.

Warning: Fully oscillate the blade angle, tilt, steering, suspension and rear 3-point to check for adequate clearance.

If necessary, purchase and install steering stops from your local dealership to avoid collision and subsequent damage. The minimum clearance between the front support pin and the tire should be 1".

The minimum clearance between any part on blade and front tires when blade is fully angled, should be 3". If more clearance is necessary between blade and front tires, call Grouser Products to purchase extension on page #5.

Maintenance

1. After first 8 hours of use, re-torque all bolts. Check to make sure 1" bolts at back of front support are tight against bolt heads as shown in Step #24.
2. Check all fasteners regularly to ensure proper operation of equipment.
3. Inspect all equipment for existing or potential damages every 10 hours or less.

Additional Extension

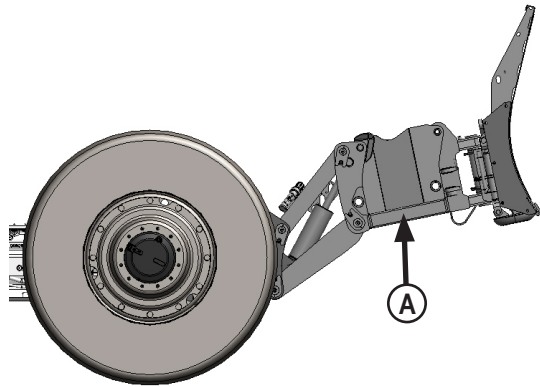

1. An additional extension (A) may be necessary if your tractor is equipped with front duals. Tire size and row spacing will determine if your system will require the extension.
2. All 650 and 710 dual front tire configurations require the extension.
3. Call Grouser with tire information to discuss if the extension is necessary for your system.

NOTE: Grouser Products is not responsible for damage to tires or blade if the extension is not installed.

NOTE: Front Dual Extension required if tractor is set up with the tire width of 150" or more on the 2-way, 4-way or 6-way blade.

Extension Installation

1. If blade system is on the FH-440 lift system, disconnect the blade system from the FH-440 lift system.
2. Center and raise the extension until the top pins are fully engaged in the top hooks of the blade system.
3. Insert the lock out pins to attach the extension to the blade system.
4. Secure both lock out pins with 1/2" x 3-1/2" bolts and 1/2" lock nuts.
5. Position and attach the adapter stand in the down position as shown below.
6. Secure the hoses from the blade system to the left side of the extension with a cordura strap, 3/8" flat washer and 3/8" nyloc nut. Verify that all hoses have some slack to move when operating all of the blade functions.
7. Connect the extension with blade system to the FH-440 lift system.
8. Shut off the tractor engine and set the parking brake.
9. Pull the quick attach lock handle and lift the locking latch to lock the handle in place.
10. Clean hydraulic couplers and connect hydraulic couplers on the top arm. Refer to AG240 Dozer Owner's Manual and Parts Book for proper location of all functions.
11. Start tractor engine and raise lift system until the adapter stand is off the ground.
12. Shut off tractor engine and set parking brake.
13. Remove hitch pin with chain, rotate stand up and reattach with the pin.

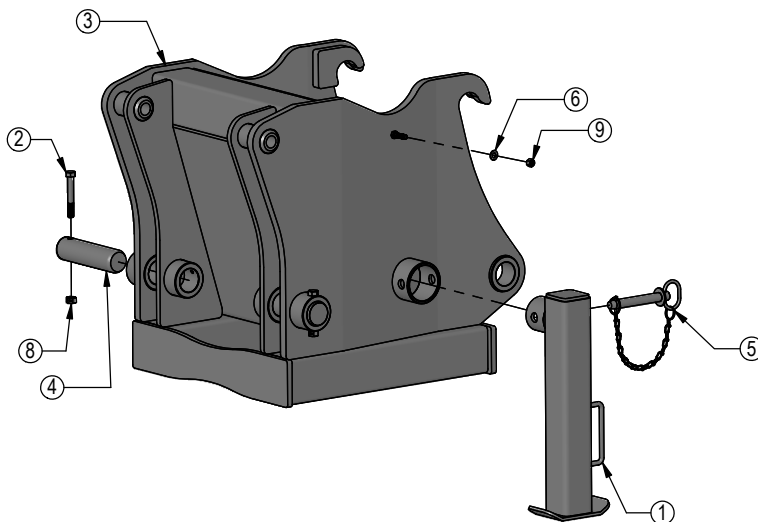

ITEM NO.	QTY.	PART NO.	DESCRIPTION
1	1	11-40610R1	440 To 240 Adapter Stand
2	2	16-20134	1/2" x 3-1/2" Hex Bolt Gr. 5 NC
3	1	32-40285R2	FH440 To 240 Extension
4	2	43-16923R2	Lock Out Pin
5	1	43-40453	Hitch Pin with Chain
6	1	57-20742	3/8" Flat Washer
7*	1	59-16899-6	Heavy Duty Velcro Strap
8	2	70-20604	1/2" Center Lock Hex Nut
9	1	70-20612	3/8" Nyloc Nut

* Part Not Shown

ITEM NO.	Ag 240 Blade QTY.	9-16 Blade QTY.	PART NO.	DESCRIPTION
1	4	4	16-1415025	14mm x 1.50mm x 25mm Hex Bolt Gr. 10.9
2	2	2	16-1510	20mm x 2.5mm x 90mm Hex Bolt Gr 10.9
3	12	12	16-1878	20mm x 2.5mm x 50mm Hex Bolt Gr 10.9
4	2	2	16-20032	5/16" x 3/4" Hex Bolt Gr 5 NC
5	2	2	16-20035	5/16" x 1-1/4" Hex Bolt Gr. 5
6	2	2	16-20250210	20mm x 2.50mm x 210mm Hex Bolt Gr 10.9
7	2	2	16-20558	1" x 2" Hex Bolt Gr 8 NC
8	4	4	16-2487	20mm x 2.5mm x 60mm Hex Bolt Gr. 10.9
9	4	4	16-2489	20mm x 2.5mm x 120mm Hex Bolt Gr 10.9
10	1	1	17-42550	Mount Weld
11	1	2	18-40280	Hose Clamp Bracket
12	1	1	18-40330	Hose Channel
13	2	2	19-40281	Stand Off
14	2	2	NA	Grouser Dozer Metal Serial Tag
15	2	2	27-18887	Grouser Name Plate Decal
16	2	2	43-43709	Pin
17	2	2	44-19789	Pin Retainer Plate
18	1	1	44-41860	Master Plate Weld
19	1	1	54-19790	Front Support Weld
20	26	26	57-19088	3/4" Hardened HD Flat Washer
21	2	2	57-20740	1/4" Flat Washer
22	4	4	57-20824	14mm Flat Washer
23	2	4	70-20604	1/2" Center Lock Hex Nut
24	2	2	70-20611	5/16" Nyloc Hex Nut Gr. 5
25	2	2	70-20872-10	20mm Hex Nut 2.5 Pitch Class 10

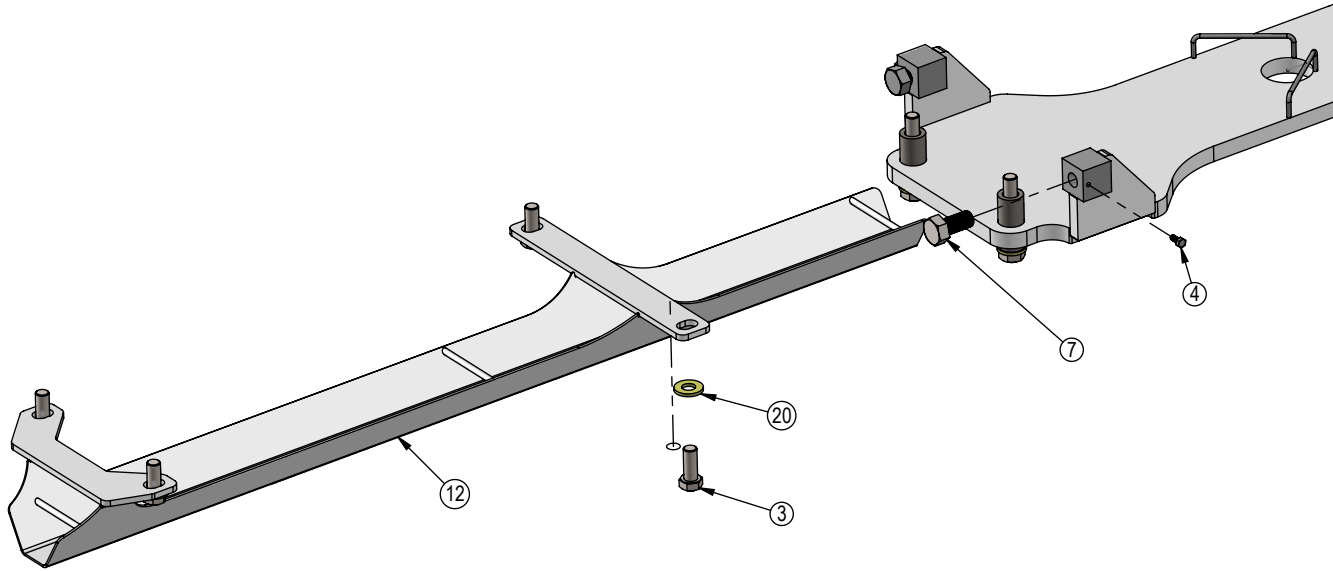

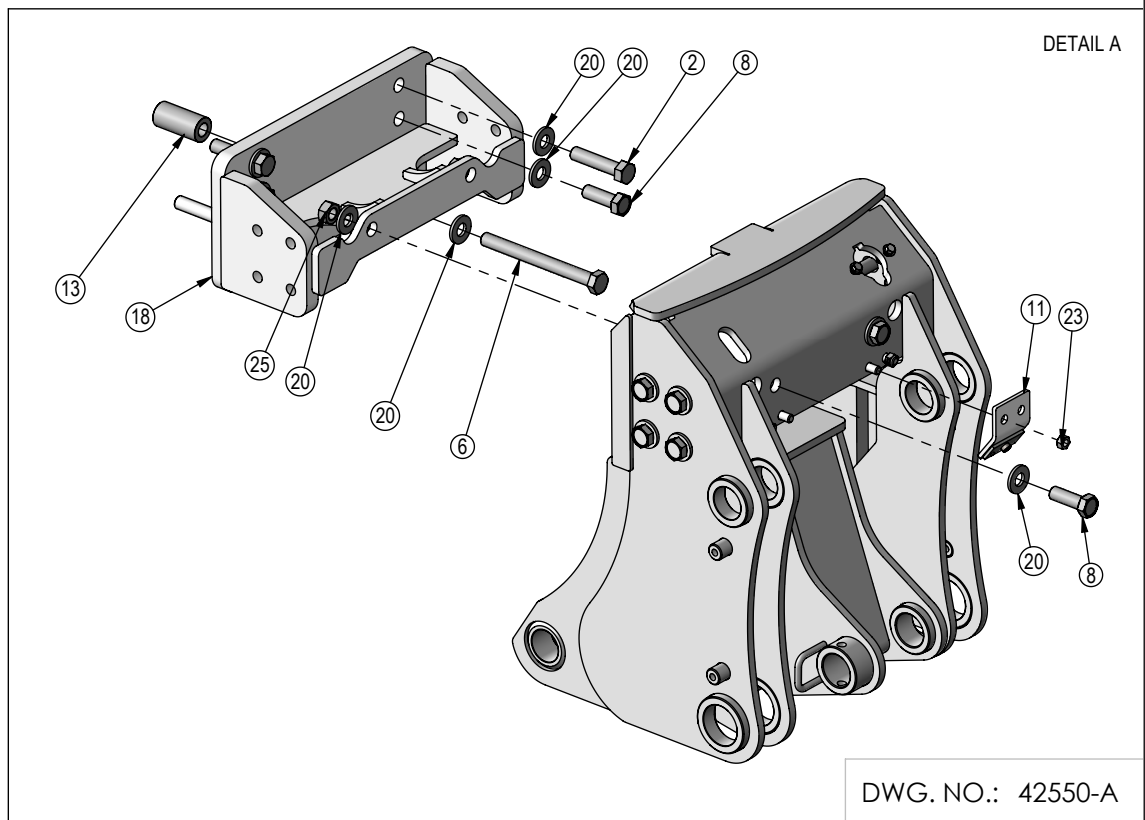
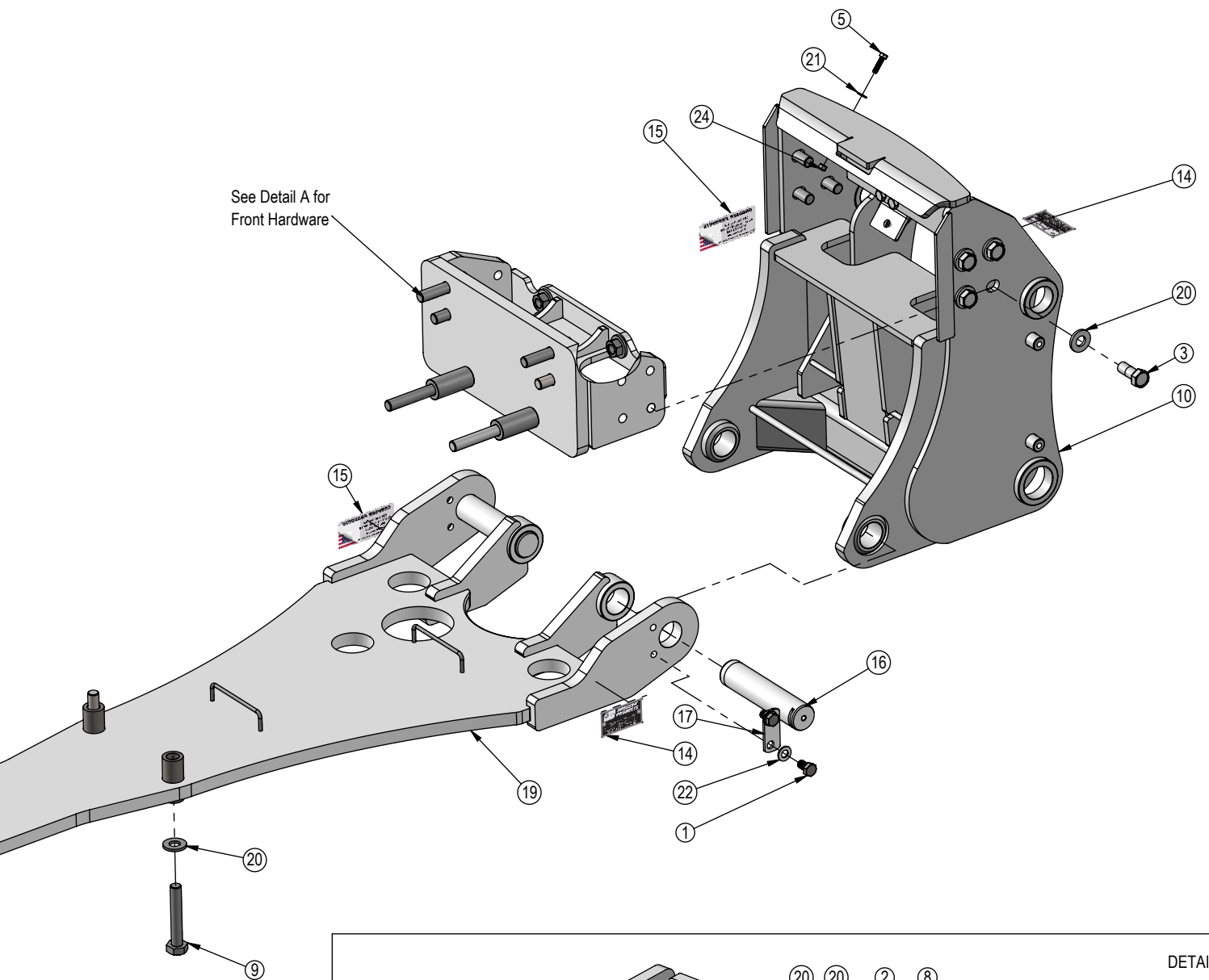

DWG. NO.: 42550-A

Contact Us

As always, if you have any questions about your undercarriage or other products made by Grouser, feel free to contact us.

Grouser Products

755 2nd Ave NW - West Fargo, ND 58078

Phone: 1-701-282-7710

Fax: 1-701-282-8131

E-mail: info@grouser.com

Website: www.grouser.com

Improvements

Grouser Products Inc. is continually striving to improve its products. We reserve the right to change prices, specification, or equipment at any time without notice. We also reserve the right to make improvements or changes when it becomes practical and possible to do so without incurring any obligation to make changes or additions to the equipment sold previously.

Warranty

Grouser Products warrants to the original purchaser of each item that the product be free from defects in material and workmanship under normal use and service for a period of two years. If such equipment is found to be defective within two years, it is the obligation of Grouser Products under this warranty to repair or replace (exclusive of the cost of labor and transportation), any equipment or parts, in the judgment of Grouser Products to be defective in material or workmanship.

All equipment or parts claimed to be defective in material or workmanship must be made available for inspection at the place of business of a dealer authorized to handle the equipment covered by this warranty, or, upon request by Grouser Products, shipped to the Grouser Products factory in West Fargo, North Dakota. Grouser Products shall have no obligation to bear the cost of labor or transportation in connection with replacement or repair of any such defective parts in the setup process.

This warranty covers only defects in material and workmanship. It does not cover depreciation or damage caused by normal wear, accident, improper assembly, improper adjustments, improper maintenance including lack of proper lubrication, or improper use. Therefore, Grouser Products liability under this warranty shall not be effective or actionable unless the equipment is assembled, maintained and operated in accordance with the operating instructions accompanying the equipment. Grouser Products shall have no liability if the equipment has been altered or reworked without the written authorization of Grouser Products.

Grouser Products' parts, which are furnished under this warranty and properly installed, shall be warranted to the same extent as the original parts under this warranty if, and only if, such parts are found to be defective within the original warranty period covering the original equipment.

