

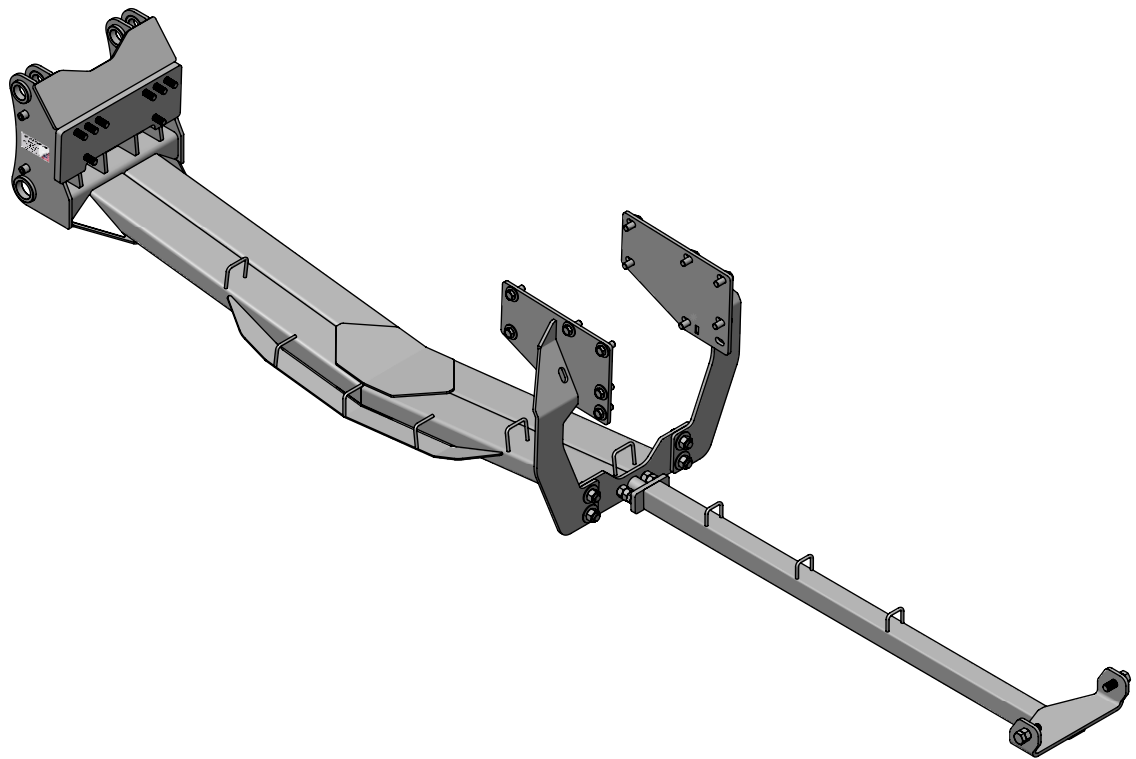

Case Magnum - Tier 4A & 4B Undercarriage Installation Instructions



For Models:
Case Magnum Suspended Front Axle
(With 5" Rear Axles):
340, 370, 380

Purchase Date
Serial Number
Model Number
Tractor Model
Dealer

To The Owner

This manual contains information concerning the installation of the undercarriage. You have purchased dependable, long lasting equipment, but only by proper care and operation can you expect to receive the performance and long service built into our products. Please have all operators read this manual carefully and keep the manual available for ready reference. If you have any questions or concerns, contact Grouser Products.

Caution:

- Always use caution when working around any equipment.
- Always wear safety glasses.
- Follow tractor manufacturer's safety guidelines when installing this product.
- Use paint where necessary to prevent rust.
- Do not modify or permit anyone else to modify or alter the equipment and its components without first consulting Grouser Products.

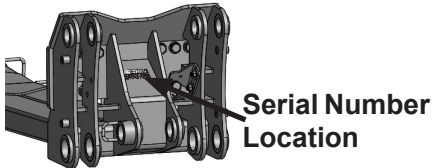

Note:

- When installing hardware, only finger tighten until all hardware is in place.
- A full diagram of the assembly with the full list of parts is on pages 6-7.
- Unstrap and remove any components that are attached for shipping.
- Read all instructions prior to performing installation.



To ensure the safety of those working under and around the machine, apply parking brake, remove key from ignition, and block tires before working on the machine.

Installation

1. Remove weights and weight bracket from front of tractor if necessary.
2. Position the undercarriage under tractor and center on the frame of the tractor.

NOTE: When lifting the undercarriage, watch for any potential pinching of hoses or any other components to prevent damage.

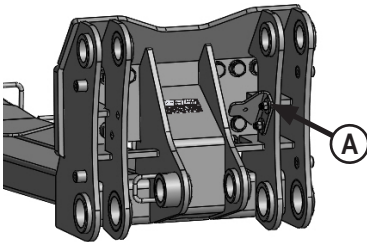

3. Remove hose clamp brackets (A) from front of undercarriage mount to gain access to front bolts.

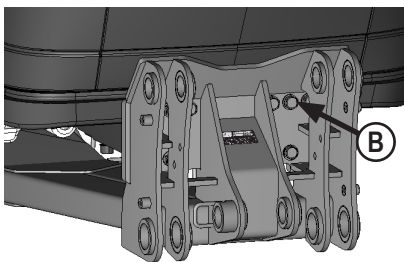

4. Lift undercarriage and attach front of undercarriage to tractor with 8 - 20mm x 70mm bolts and 8 - 3/4" flat washers (B).

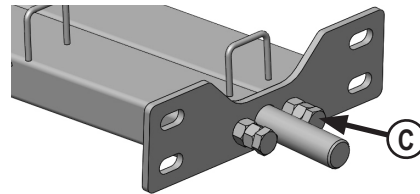

5. Install 2 - 1" x 3" bolts and 2 - 1" nuts at rear of undercarriage. Turn 1" bolts in. The bolts and nuts will be adjusted after push pole is installed (C).

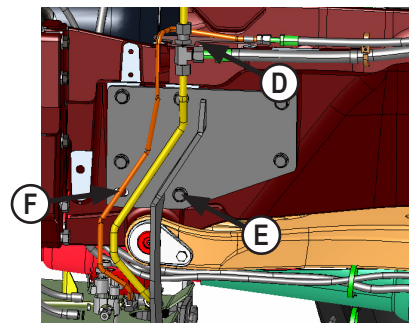

6. Loosen bracket that holds steel line on right side of tractor engine (D). This allows room for side plate to be installed.
7. Attach side brackets to tractor with 13 - 20mm x 50mm bolts and 13 - 3/4" flat washers (E). Eliminate bottom left bolt on right side plate due to steel line obstruction (F).
8. Tighten bracket that holds steel line on right side of tractor engine after side plate is in position.

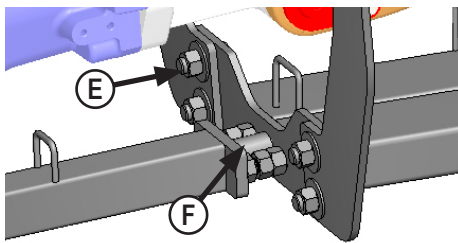

9. Attach side brackets to undercarriage with 4 - 1" x 2" bolts, 8 - 1" flat washers and 4 - 1" nuts (E).
10. Position push pole under tractor.
11. Slide front of push pole onto rod at end of undercarriage (F).

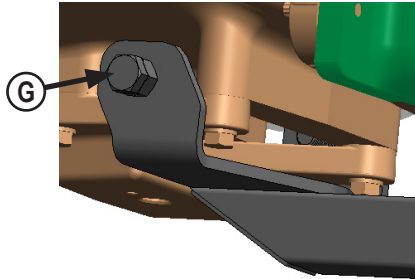

12. Raise rear of push pole up to the drawbar bracket and turn in 1" bolts on each side until tight and resting on drawbar bracket (G).

13. Torque front 20mm bolts (B) to 432 ft-lbs.
 14. Torque 1" bolts attaching side plates to undercarriage (E) to 909 ft-lbs.
 15. Torque side 20mm bolts (D) to 432 ft-lbs.
- NOTE: Verify that the push pole is touching front of drawbar bracket.**
16. Unscrew 2 - 1" x 6" bolts at rear of undercarriage until tight against push pole. Torque 1" bolts to 90-95 ft-lbs (C).
 17. Tighten nuts up tight against undercarriage. Use nuts to lock bolts in place.

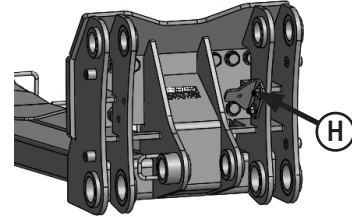

18. Reattach the hose clamp bracket (H) that was removed in Step #3.
19. Torque 1/2" nuts (H) to 75 ft-lbs.
20. Route hoses through hose loops on undercarriage and push pole to back of tractor.
21. Protect hoses around sharp corners and moving objects. Use zip ties to secure hoses in place.
22. Plug hoses into open SCV's at rear of tractor.

Assembling Lift Components

1. Refer to the Blade Owner's Manual & Parts Book for instructions on how to assemble the lift components.

Maintenance

1. After first 8 hours of use, re-torque all bolts.
2. Check all fasteners regularly to ensure proper operation of equipment.
3. Inspect all equipment for existing or potential damages every 10 hours or less.

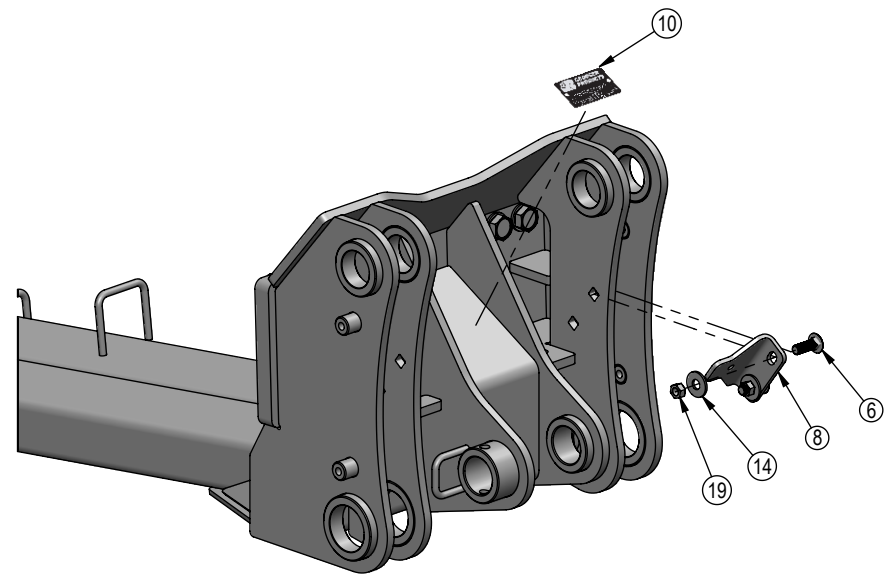
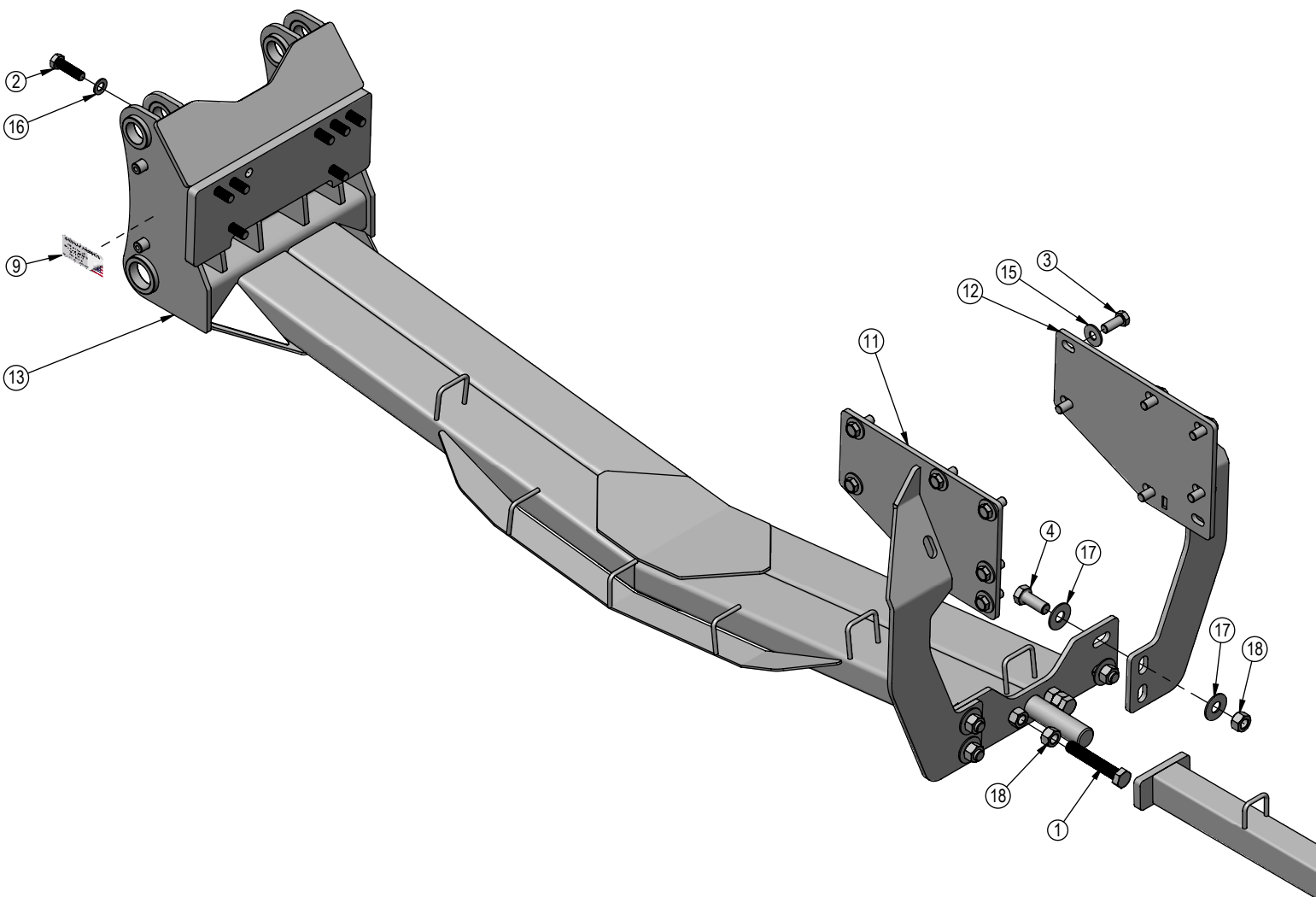

ITEM NO.	QTY.	PART NO.	DESCRIPTION
1	2	16-17271	1" X 6" Hex Bolt Gr 8 NC (Full Thread)
2	8	16-1876	20mm x 2.5mm x 70mm Hex Bolt Gr 10.9
3	14	16-1878	20mm x 2.5mm x 50mm Hex Bolt Gr 10.9
4	4	16-20560	1" x 2-1/2" Hex Bolt Gr 8 NC
5	2	16-20562	1" x 3" Hex Bolt Gr 8 NC
6	2	16-21126	1/2" x 1-1/2" Carriage Bolt Gr 5 NC
7	1	17-15875	Magnum T4 CVT Push Pole
8	1	18-42691	Hose Bracket
9	1	27-18887	Grouser Name Plate Decal
10	1	NA	Grouser Dozer Metal Serial Tag
11	1	44-14933-L	Side Plate, Left
12	1	44-14933-R	Side Plate, Right
13	1	54-43025	FH-440 XR Case Magnum T4A/B Undercarriage - Susp.
14	2	57-20744	1/2" Flat Washer
15	14	57-20747	3/4" Flat Washer
16	8	57-20757	3/4" Flat Washer - 1-1/2" OD
17	8	57-20819	1" Flat Washer Heavy Duty Gr 8
18	6	70-20599	1" Hex Nut Gr 8 NC
19	2	70-20604	1/2" Center Lock Hex Nut

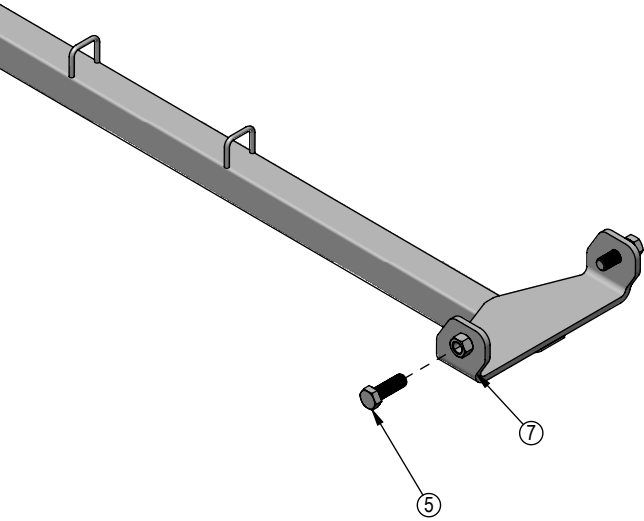

DWG. NO.: 43030-A

Notes

Notes

Contact Us

As always, if you have any questions about your undercarriage or other products made by Grouser, feel free to contact us.

Grouser Products

755 2nd Ave NW - West Fargo, ND 58078

Phone: 1-701-282-7710

Fax: 1-701-282-8131

E-mail: info@grouser.com

Website: www.grouser.com

Improvements

Grouser Products Inc. is continually striving to improve its products. We reserve the right to change prices, specification, or equipment at any time without notice. We also reserve the right to make improvements or changes when it becomes practical and possible to do so without incurring any obligation to make changes or additions to the equipment sold previously.

Warranty

Grouser Products warrants to the original purchaser of each item that the product be free from defects in material and workmanship under normal use and service for a period of two years. If such equipment is found to be defective within two years, it is the obligation of Grouser Products under this warranty to repair or replace (exclusive of the cost of labor and transportation), any equipment or parts, in the judgment of Grouser Products to be defective in material or workmanship.

All equipment or parts claimed to be defective in material or workmanship must be made available for inspection at the place of business of a dealer authorized to handle the equipment covered by this warranty, or, upon request by Grouser Products, shipped to the Grouser Products factory in West Fargo, North Dakota. Grouser Products shall have no obligation to bear the cost of labor or transportation in connection with replacement or repair of any such defective parts in the setup process.

This warranty covers only defects in material and workmanship. It does not cover depreciation or damage caused by normal wear, accident, improper assembly, improper adjustments, improper maintenance including lack of proper lubrication, or improper use. Therefore, Grouser Products liability under this warranty shall not be effective or actionable unless the equipment is assembled, maintained and operated in accordance with the operating instructions accompanying the equipment. Grouser Products shall have no liability if the equipment has been altered or reworked without the written authorization of Grouser Products.

Grouser Products' parts, which are furnished under this warranty and properly installed, shall be warranted to the same extent as the original parts under this warranty if, and only if, such parts are found to be defective within the original warranty period covering the original equipment.

