

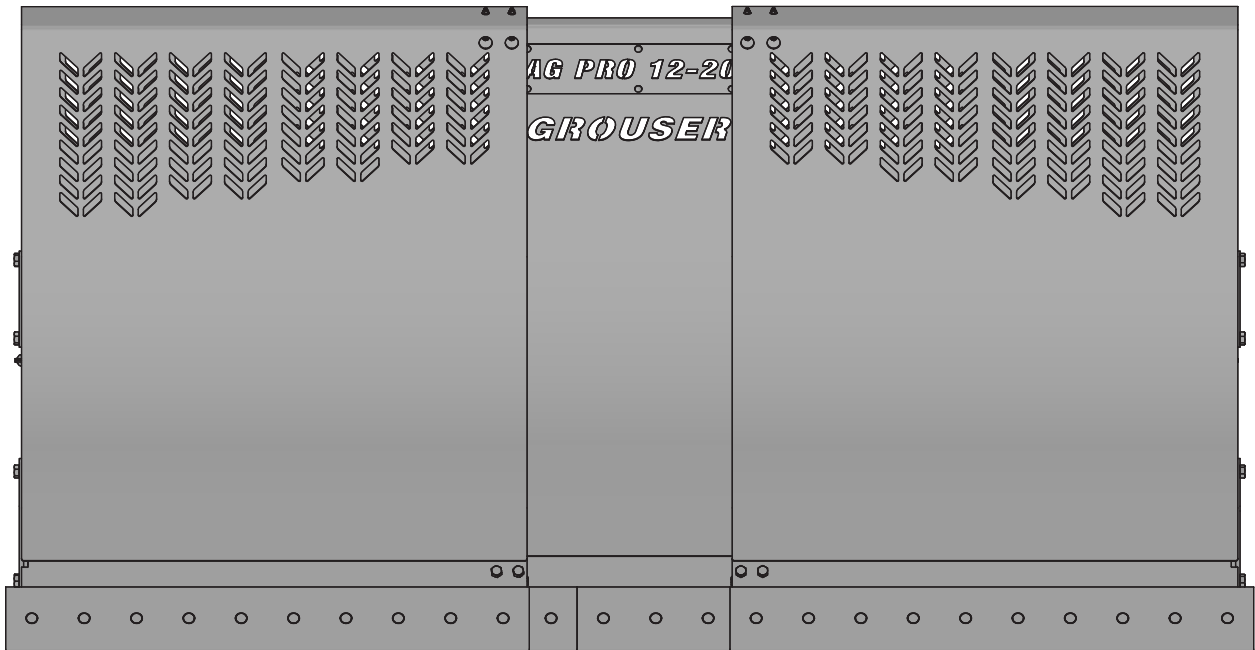

# Ag Pro 12-20

## Owner's Manual & Parts Book



**Grouser Products**  
755 2nd Ave NW - West Fargo, ND 58078  
**Phone:** 1-800-747-6182  
**Fax:** 1-701-282-8131  
**E-mail:** grouser@grouser.com  
**Website:** www.grouser.com

Purchase Date
Serial Number
Model Number
Tractor Model
Dealer

Description	Page
Welcome To The Owner _____	2
Safety Precautions, Torque Specifications & Pre-Installation _____	3
Decals _____	4
Maintenance & Lubrication _____	5
Lift System _____	6-7
Tractor Side Hydraulics _____	7-11
Initial Startup _____	12
Connecting and Disconnecting _____	13
Hydraulic Angle System Operation _____	13
Lift Speed Control Installation _____	14
Skid Shoe Adjustment & Tilt Plate Adjustment _____	15
Ag Pro 12-20 Blade _____	16-17
Hydraulic Angle - Hydraulic Tilt System _____	18-19
Hydraulic Angle - Hydraulic Tilt 2-Stick Hydraulics _____	20-21
Hydraulic Angle - Hydraulic Tilt Electric Hydraulics _____	22-23
Hydraulic Angle - No Tilt 2-Stick Hydraulics _____	24-25
Hydraulic Angle - No Tilt Electric Hydraulics _____	26-27
No Angle-Hydraulic Tilt System _____	28-29
Hydraulic Angle Blade Hydraulics _____	30-31
No Angle Blade Hydraulics _____	32-33
No Angle - No Tilt Blade _____	34-35
No Angle - No Tilt Blade Hydraulics _____	36-37
Single Control Blade Hydraulics _____	38-39
Blade Attachments & Replacement Wear Parts _____	40
Cutting Edge Replacement Instructions _____	41
Hydraulic Multi-Coupler Maintenance _____	42-43
Hydraulic Schematics _____	44-46
Wire Harness _____	47
Contact Us, Improvements, & Warranty _____	48

Thank you for your recent purchase of a Grouser 12-20 Dozer. Welcome to the family of satisfied Grouser blade owners. Grouser Products is committed to offering quality products to help professionals in their daily jobs. We are also committed to providing you the highest level of customer satisfaction possible. Again, thank you for your patronage. We look forward to serving you.

This manual contains information concerning the operation, adjustment, safety and maintenance of the 12-20 Dozer. You have purchased a dependable, long lasting piece of equipment. You can expect to receive long lasting performance and long service built into our products with proper care and operation. Please have all operators read and understand this manual carefully. Keep the manual available for reference. If, for any reason, you have questions or comments, we would be happy to hear from you. Call our toll-free number, 800-747-6182, or send us an e-mail at [info@grouser.com](mailto:info@grouser.com). You can expect us to respond to your e-mail in a timely manner.

A careful operator is the best operator. Most accidents can be avoided by observing certain precautions. To help prevent accidents, read and take the following precautions before operating this equipment. In addition, please follow all safety and operational instructions of your tractor manufacturer.

### The 12-20 Dozer:

1. The 12-20 Dozer should be operated only by those who are responsible and instructed to do so.
2. Read the owner's manual carefully before using this equipment. Lack of operating knowledge can lead to accidents.
3. Keep the 12-20 Dozer maintained in reliable and satisfactory condition to ensure your safety.
4. Make sure the area is clear of people before moving any equipment.
5. Do not modify or permit anyone else to modify or alter the equipment and its components without first consulting Grouser Products.
6. Lower the blade to the ground when not in use.

### Servicing the 12-20 Dozer:

1. Read and follow all safety instructions provided by the tractor manufacturer.
2. Always use proper personal safety gear when performing maintenance on equipment.
3. Before servicing, relieve hydraulic pressure, stop engine and fully engage parking brake.
4. Escaping hydraulic fluid under pressure can penetrate skin causing serious injury. If fluid is injected into skin, obtain medical attention immediately.
  - DO NOT use your hand to check for leaks. Use a piece of cardboard or paper to search for leaks.
  - Stop the engine and relieve pressure before connecting or disconnecting lines.
  - Tighten all connections before starting the engine or pressurizing lines.

### Storing the 12-20:

1. Thoroughly clean the 12-20 Dozer before storage. Use paint where necessary to prevent rust.
2. Check the 12-20 Dozer for worn or damaged parts. Install new parts as required.
3. Lubricate all pins and joints.

Tighten all bolts to the values listed below unless otherwise noted. Refer to the parts lists for proper length and grade of the bolts.

Size	Torque - Dry (ft-lbs)			
	SAE Grade 5		SAE Grade 8	
	UNC	UNF	UNC	UNF
5/16	17	19	24	27
3/8	30	35	45	50
7/16	50	55	70	80
1/2	75	85	110	120
9/16	110	120	150	170
5/8	150	170	210	240
3/4	260	300	380	420
7/8	430	470	600	670
1	640	720	910	1020

Size	Torque - Dry (ft-lbs)
	Grade 10.9
M18 x 2.50	284
M20 x 2.50	401
M22 x 2.50	547
M24 x 3.00	694

Unstrap and remove the lift frame, hoses, top arms, and any boxes of hardware from the undercarriage. If any components are missing, call Grouser.

Install undercarriage per the tractor specific mounting instructions.

6 7 8 9 10 10 9 8 7 6  
PN: 27-15612-L PN: 27-15612-R

**AG PRO**  
**12-20**

PN: 27-15598



**WARNING**  
**PINCH AREA**  
Keep away  
Failure to comply could result in death or serious injury.

27-2409

PN: 27-2409



**GROUSER PRODUCTS**  
755 2nd Ave NW-West Fargo, ND 58078  
800-747-6182/701-262-7710  
1020XXXX  
This product may be protected by one or more of the following patents and trademarks:  
6431288 6422322 2227998 2227996  
6527155 6907241 6955229 7131552



**WARNING**  
Cancer and Reproductive Harm  
For more information go to  
[www.P65Warnings.ca.gov](http://www.P65Warnings.ca.gov)

27-40962

PN: 27-40962

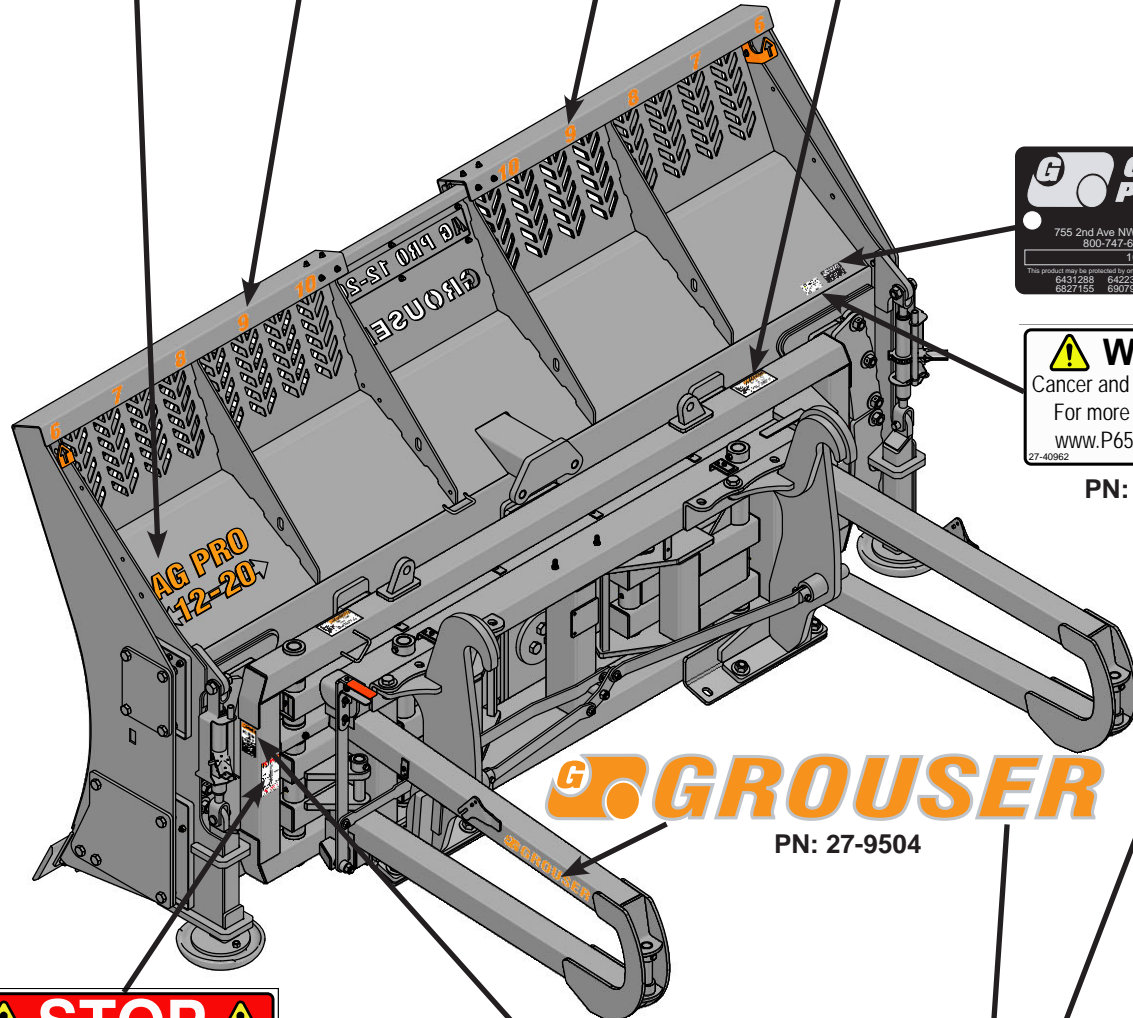

**G GROUSER**

PN: 27-9504

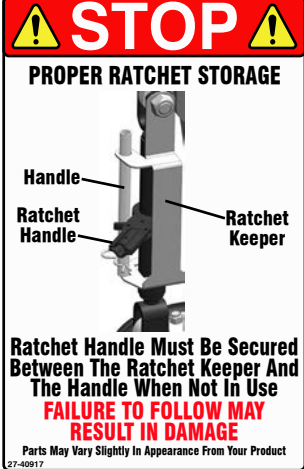

**STOP**  
**PROPER RATCHET STORAGE**

Handle  
Ratchet Handle  
Ratchet Keeper

Ratchet Handle Must Be Secured Between The Ratchet Keeper And The Handle When Not In Use  
**FAILURE TO FOLLOW MAY RESULT IN DAMAGE**  
Parts May Vary Slightly In Appearance From Your Product  
27-40917

PN: 27-40917



**WARNING**

**PINCH POINT**  
AVOID INJURY FROM FRAME PIVOT AND STOPS.  
• Keep hands and feet away.

27-9503

PN: 27-9503  
Left and Right Side

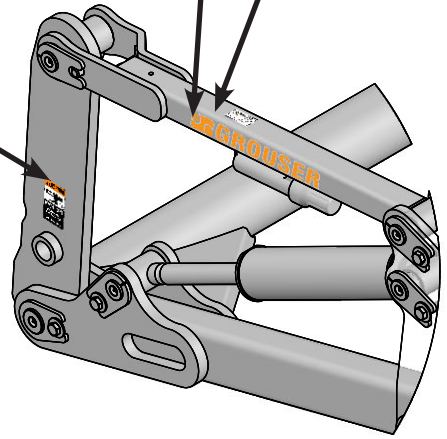

Due to the harsh environment this equipment operates in, the following tasks should be performed every 10 hours or less.

- Inspect all equipment before operation for existing or potential damage.
- Lubricate all joints with high quality grease. See below for grease locations.
- Inspect all bolts, and tighten any loose bolts to torque specifications on page 3.
- Check replaceable cutting edge for wear ensuring there is enough material to prevent permanent damage to the 12-20 Dozer. For cutting edge information, see pages 16-17 and 41.
- Check hydraulic cylinders and hoses for damage or leaks. For replacement parts, see hydraulic pages 6-11 and 20-39.
- Make sure all non-rotating pins are secured properly.
- Inspect all decals and order replacement decals from your dealer if any are damaged or worn.
- For multi-coupler maintenance, see pages 42-43.
- Inspect all tilt-ways for wear. See page 15 for tilt plate adjustment.
- Replace parts with original parts only.

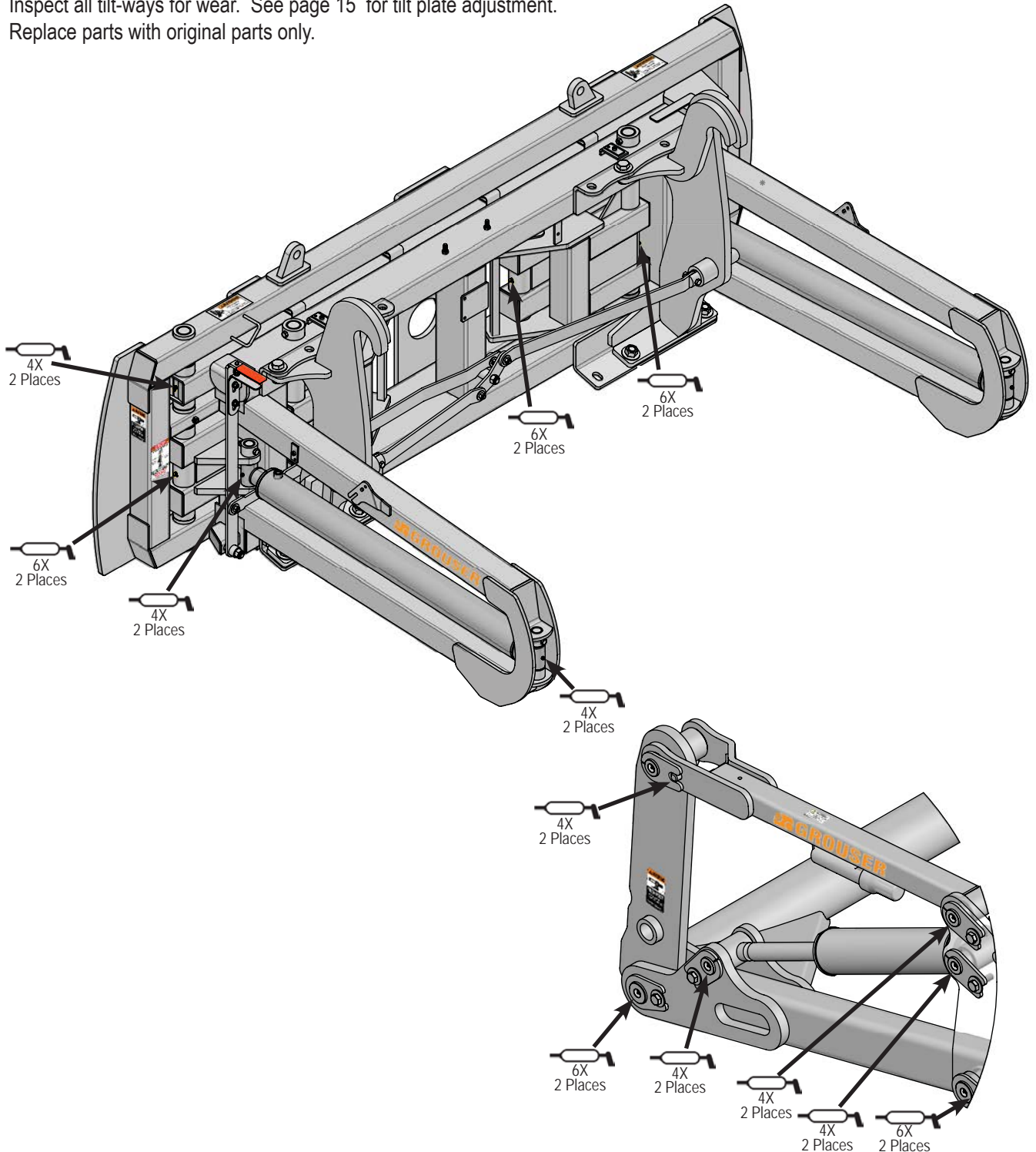

Some assembly of Lift System components is necessary. Follow the steps listed below. See diagram below for the correct hardware and orientation of parts.

1. Remove all pins and fasteners on each side of the undercarriage and set aside for later installation.
2. Position the lift frame between the two plates on both sides of the undercarriage and align to the bottom holes.
3. Insert pins and hardware to attach the lift frame, the base end of the lift cylinders, and the top arms to the undercarriage.
4. Insert pins and hardware to attach the male quick attaches to the lift frame, and to the top arms. Use 2" washers as shims to keep top arm pins tight and in place. Only use as many as needed until pin is tight.
5. Torque all fasteners according to the specifications on Page 3.

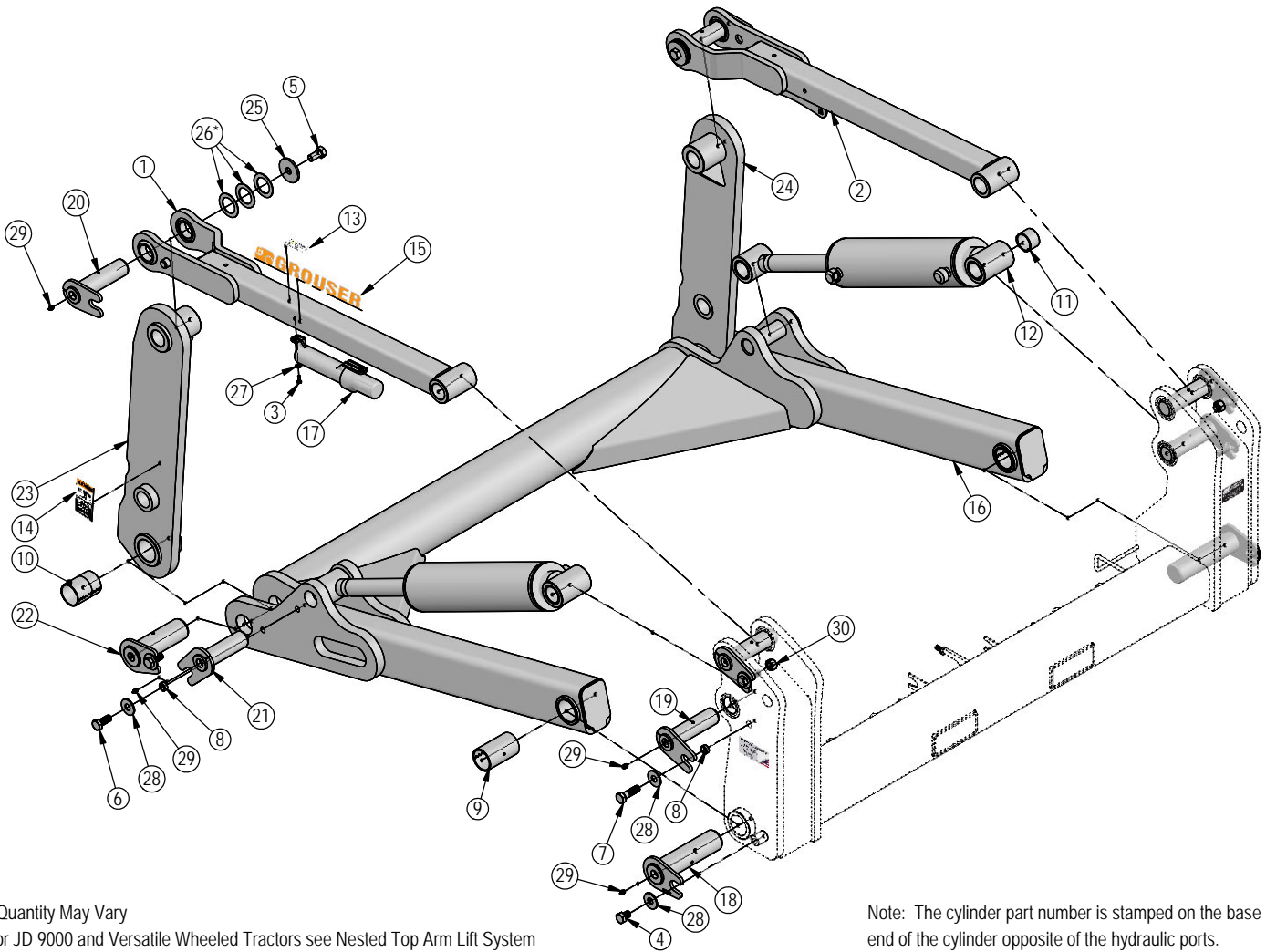

\* Quantity May Vary

For JD 9000 and Versatile Wheeled Tractors see Nested Top Arm Lift System

ITEM NO.	QTY.	PART NO.	DESCRIPTION
1	1	11-19975-L	Top Arm Weld
2	1	11-19975-R	Top Arm Weld
3	2	16-20002	1/4" x 3/4" Hex Bolt Gr 5 NC
4	2	16-20214	3/4" x 1" Hex Bolt Gr 5 NC
5	2	16-20216	3/4" x 1-1/2" Hex Bolt Gr 5 NC
6	4	16-20217	3/4" x 1-3/4" Hex Bolt Gr 5 NC
7	4	16-20220	3/4" x 2-1/2" Hex Bolt Gr 5 NC
8	8	19-13515	Spacer, NR Pin
9	2	19-13525	2.75 x 2.50 x 4.75 Spring Bushing
10	2	19-18089	2.75 x 2.50 x 3.75 Spring Bushing
11	8	19-16695	2.25 x 2.00 x 1.50 Spring Bushing
12	2	26-34751	5 x 18 Hydraulic Cylinder
13	1	27-40962	Warning Prop 65 Decal
14	2	27-9503	Pinch Decal (Foot)
15	2	27-9504	Grouser Horizontal Decal
16	1	32-42335	Lift Frame

Note: The cylinder part number is stamped on the base end of the cylinder opposite of the hydraulic ports.

Cylinder	Part No.	Description
26-34751	49-12275	Seal Kit 5 x 18 Nitrided Rod

ITEM NO.	QTY.	PART NO.	DESCRIPTION
17	1	34-14961	Manual Canister Small
18	2	43-14725	Lift Frame / UC Pin
19	4	43-18120	Top Pin Weld
20	2	43-18127	Top Arm Pin Weld
21	2	43-18175	Lift Cyl Pin Weld
22	2	43-18635	Ag Pro Plus QA Pin
23	1	45-18110-L	Male Quick Attach, Ag Pro S
24	1	45-18130-R	Male Quick Attach, Ag Pro S
25	2	57-1530	3" OD X .75 ID X .25" HD Flat Washer
26*	6	57-1811	2" Washer
27	2	57-20740	1/4" Flat Washer
28	10	57-20747	3/4" Flat Washer
29	12	58-9369	Straight 1/8" NPT Grease Zerk
30	2	70-20607	3/4" Center Lock Hex Nut Gr 2 NC

Note: Refer to Pages 8-11 for the correct hose lengths and hose location.

Note: All connections are identified by spiral bands. 2 bands are from the base end of a cylinder and 1 band is from the rod end of a cylinder. Orange = Lift, Green = Tilt, Red = Angle, Yellow = Angle 2-Stick, Blue = Left Blade Cylinder, and Brown = Right Blade Cylinder.

1. Connect the lift hoses to the lift cylinders.
2. Verify that hoses are not twisted and protected from rubbing on any sharp edges. See Pages 8-11 for proper hose routing.
3. Install the 45° fittings into the multi-couplers on both top arms.
4. Identify each remaining hose at the front of the undercarriage by the colored bands on the end of the hose and connect the hose to the corresponding 45° fitting on the multi-coupler. Refer to Pages 8-11 for proper hose locations.
5. Hoses were plugged into the rear of the tractor during the undercarriage installation. If system is Hydraulic Angle with 2-Stick, verify that the 35" hose was installed and plumbed correctly at the back of the tractor. Refer to Page 8-9 or the Hydraulic Schematic on Page 44.
6. Refer to Page 14 for Lift Speed Control Installation instructions.
7. Continue on Page 12 for initial startup instructions.

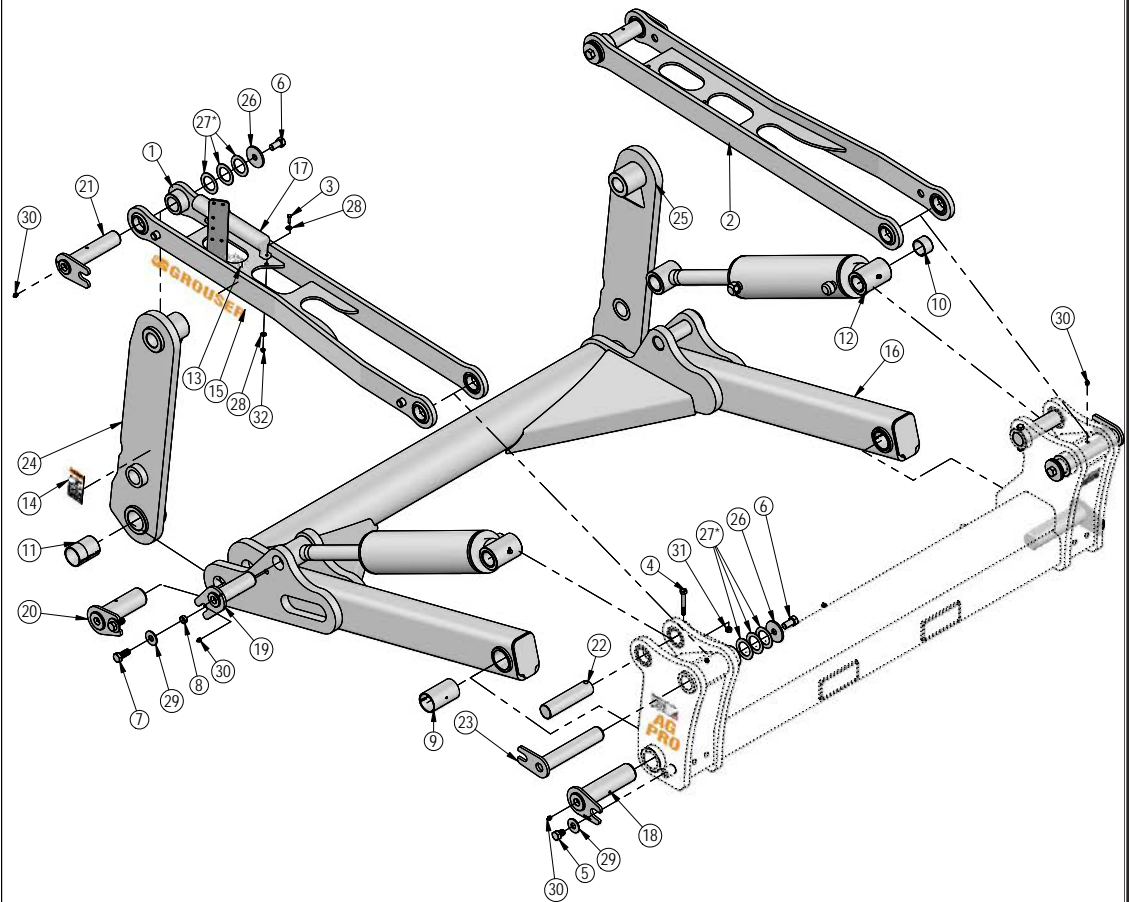

\* Quantity May Vary

ITEM NO.	QTY.	PART NO.	DESCRIPTION
1	1	11-19035-L	Nested Top Arm Weld
2	1	11-19035-R	Nested Top Arm Weld
3	2	16-20004	1/4" X 1" Hex Bolt Gr 5 NC
4	2	16-20134	1/2" x 3-1/2" Hex Bolt Gr 5 NC
5	2	16-20214	3/4" x 1" Hex Bolt Gr 5 NC
6	4	16-20216	3/4" x 1-1/2" Hex Bolt Gr 5 NC
7	4	16-20217	3/4" x 1-3/4" Hex Bolt Gr 5 NC
8	4	19-13515	Spacer, NR Pin
9	2	19-13525	2.75 x 2.50 x 4.75 Spring Bushing
10	8	19-16695	2.25 x 2.00 x 1.50 Spring Bushing
11	2	19-18089	2.75 x 2.50 x 3.75 Spring Bushing
12	2	26-34752	5 x 18 Hydraulic Cylinder With Zerk
13	1	27-40962	Warning Prop 65 Decal
14	2	27-9503	Pinch Decal (Foot)
15	2	27-9504	Grouser Horizontal Decal
16	1	32-42335	Lift Frame
17	1	34-14961	Manual Canister Small
18	2	43-14725	Lift Frame / UC Pin

Note: The cylinder part number is stamped on the base end of the cylinder opposite of the hydraulic ports.

Cylinder	Part No.	Description
26-34751	49-12275	Seal Kit 5 x 18 Nitrided Rod

ITEM NO.	QTY.	PART NO.	DESCRIPTION
19	2	43-18175	Lift Cyl Pin Weld
20	2	43-18635	Ag Pro Plus OA Pin
21	2	43-19040	Top Arm - Quick Attach Pin Weld
22	2	43-19041	Pin, Lift Cylinder
23	2	43-19043	Top Arm - Undercarriage Pin Weld
24	1	45-18110-L	Male Quick Attach, Ag Pro S
25	1	45-18110-R	Male Quick Attach, Ag Pro S
26	4	57-1530	3" OD X .75 ID X .25" HD Flat Washer
27*	12	57-1811	2" Washer
28	4	57-20740	1/4" Flat Washer
29	6	57-20747	3/4" Flat Washer
30	10	58-9369	Straight 1/8" NPT Grease Zerk
31	2	70-20604	1/2" Center Lock Hex Nut
32	2	70-20610	1/4" Nyloc Hex Nut Gr 5 NC

ITEM NO.	PART NO.	HAHT 2-Stick QTY.	HAHT Electric QTY.	HANT 2-Stick QTY.	HANT Electric QTY.	NAHT QTY.	NANT QTY.	DESCRIPTION
1	16-18957	4	4	-	-	-	-	5/16" x 3-1/4" Allen Head Screw
2	16-20124	2	2	2	2	2	-	1/2" x 1" Hex Bolt Gr 5 NC
3	16-812525	-	2	2	2	2	-	8mm x 1.25mm x 25mm Metric Hex Bolt Gr 10.9
4	18-19995-L	1	1	1	1	1	-	Multi-Coupler Mount
5	25-19861	1	-	-	-	-	-	Multi-Coupling Plate - 5 Port - Fixed
6	25-19863	1	-	-	-	-	-	Multi-Coupling Plate - 5 Port - Cap
7*	25-19864	-	1	1	-	-	-	Multi-Coupling Plate - 4 Port Fixed
8*	25-19867	-	1	1	-	-	-	Multi-Coupling Plate - 4 Port - Cap
9*	25-19868	-	-	-	1	1	-	Multi-Coupling Plate - 2 Port - Fixed
10*	25-19871	-	-	-	1	1	-	Multi-Coupling Plate - 2 Port - Cap
11	25-19870	5	-	-	-	-	-	Multi-Coupling Plate - Male Coupler
12	25-34342	8	6	6	4	4	2	Tappet Quick Coupler Male - Poppet Style
13	25-3401	2	-	2	-	-	-	Pioneer Dust Cap Left Angle (Yellow)
14	25-3453	2	2	-	-	2	-	Pioneer Dust Cap Tilt (Green)
15	25-3455	2	2	2	2	-	-	Pioneer Dust Cap Angle (Red)
16	25-3457	2	2	2	2	2	2	Pioneer Dust Cap Lift (Orange)
17	25-40407	6	-	-	-	-	-	Multi-Coupling Plate - Snap Ring
18	25-40414	1	-	-	-	-	-	Multi-Coupling Plate - Female Cap
19	31-11699-10-10	2	2	2	2	2	2	JIC Union
20	31-15199-8-8	5	4	3	2	2	-	JIC Union Elbow 90°
21	31-34032	2	2	2	2	2	2	Bulkhead Run Tee JIC
22	31-34042	4	4	4	4	4	4	Straight JIC x O-Ring
23A,B	31-34051	6	4	4	2	2	-	Straight Thread Elbow 90° JIC x O-Ring
23C	31-6802-08-10	6	4	4	2	2	-	Straight Thread Elbow 45° JIC x O-Ring
24A,B	31-34059	2	2	2	2	2	2	Straight Thread Elbow 90° JIC x O-Ring
24C	31-6802-12-10	2	2	2	2	2	2	Straight Thread Elbow 45° JIC x O-Ring

\*Parts Not Shown

Hoses Not Drawn to Scale

Item A for CNH, JD 9R, JD 9030

Item B for Versatile, Challenger MT900 and JD 9RX

Item C for Claas Xerion

HAHT 2-Stick Shown. See Page 11 for remaining Multi-Coupler Configurations.

Every hydraulic function from the front to the back of the system is designated by a  $\square$  and a letter and can also be referenced on the Hydraulic Schematics on Page 44-45.

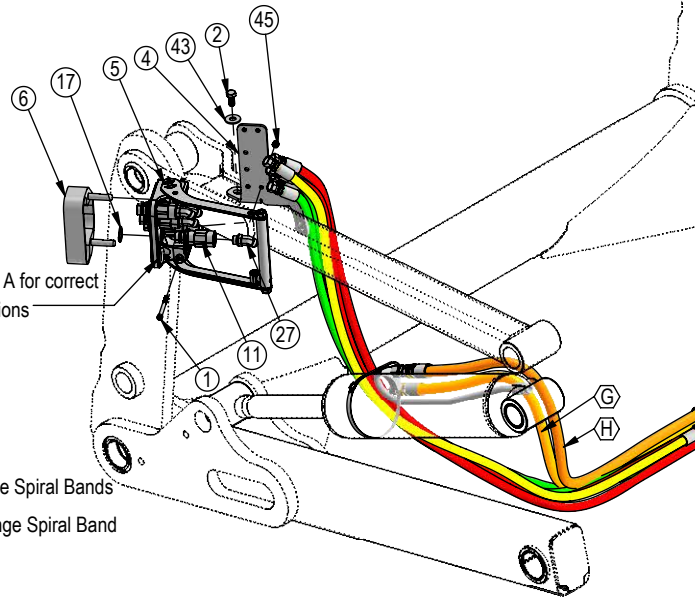
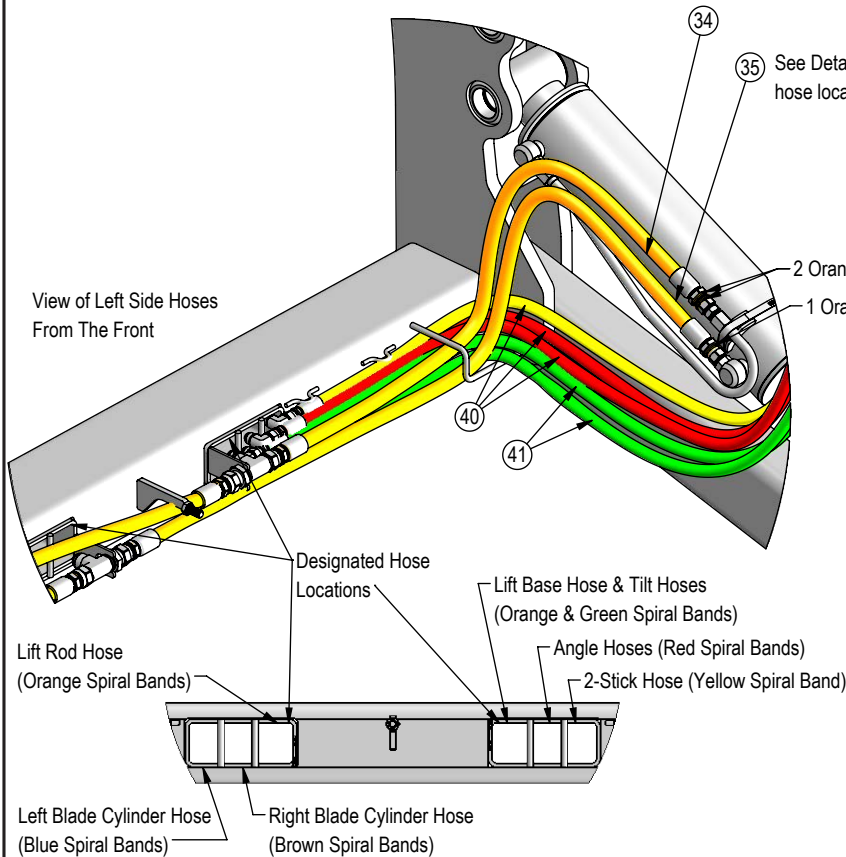

DETAIL A

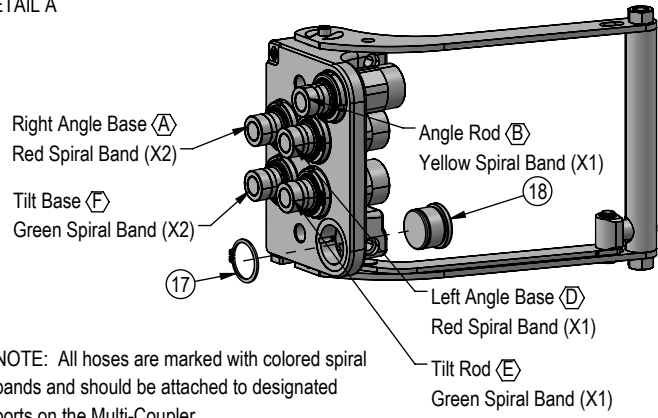



ITEM NO.	PART NO.	HAHT 2-Stick QTY.	HAHT Electric QTY.	HANT 2-Stick QTY.	HANT Electric QTY.	NAHT QTY.	NANT QTY.	DESCRIPTION
25	31-34090	1	-	1	-	-	-	Swivel Nut Run Tee JIC
26	31-34100	1	-	1	-	-	-	Swivel Nut Elbow 90° JIC
27	31-34150	5	4	3	2	2	-	Straight Thread Elbow 45° JIC x O-Ring
28	34-12932	2	2	2	2	2	2	Cylinder Saddle
29	34-12933	2	2	2	2	2	2	Hose Clamp (worm drive - 5.0)
30	34-18888-GR	9	9	-	-	9	-	-12 Green - Spiral Band
31	34-18888-RD	11	10	11	9	-	-	-12 Red - Spiral Band
32	34-18888-YL	4	-	4	-	-	-	-12 Yellow - Spiral Band
33	34-19494-OR	15	15	15	15	15	15	-16 Orange - Spiral Band
34	35-12636-0535	2	2	2	2	2	2	53.5" x 5/8" -10JIC/-12JIC Hose W/Cordura
35	35-12636-0670	2	2	2	2	2	2	67" x 5/8" -10JIC/-12JIC Hose W/Cordura
36	35-18240	2	2	2	2	2	2	Lift Cylinder Steel Line
37	35-30121	1	-	1	-	-	-	35" x 1/2" -8JIC / -8JIC Hose
38A,C	35-30183	5	4	3	2	2	-	293" (24.42") x 1/2" -8JIC/-8JIC Hose w/ Cordura
38B	35-18953-3200	5	4	3	2	2	-	320" (26.67") x 1/2" -8JIC/-8JIC Hose w/ 180" Cordura
39A,C	35-12329-3000	2	2	2	2	2	2	300" (25") x 3/4" -12JIC/-12JIC Hose w/ Cordura
39B	35-18984-3200	2	2	2	2	2	2	320" (26.67") x 3/4" -12JIC/-12JIC Hose w/ 180" Cordura
40	35-31135	3	2	3	2	-	-	78" x 1/2" -8JIC/-8JIC Hose W/Cordura
41	35-31136	2	2	-	-	2	-	81" x 1/2" -8JIC/-8JIC Hose W/Cordura
42*	57-20741	-	2	2	2	2	-	5/16" Flat Washer
43	57-20744	2	2	2	2	2	-	1/2" Flat Washer
44*	69-1531	-	1	-	1	-	-	Electric Wire Harness - Tractor Side
45	70-20611	4	4	-	-	-	-	5/16" Nyloc Hex Nut Gr. 5
46	70-20809	2	2	2	2	2	2	1-1/16" Hex Jam Nut

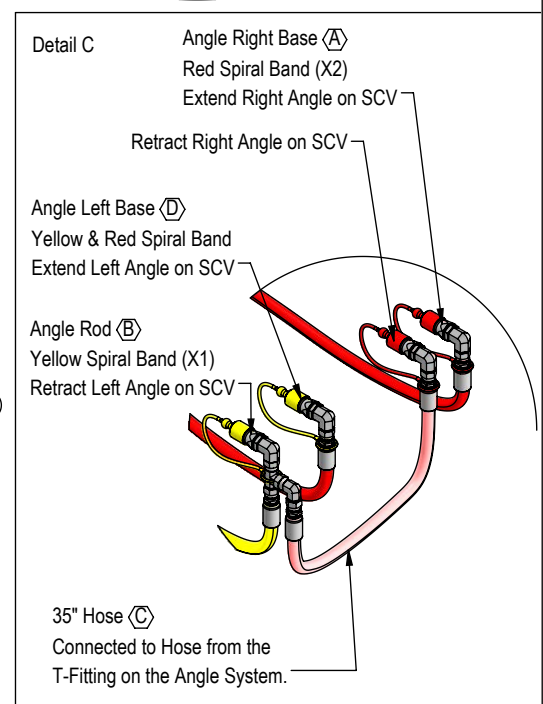
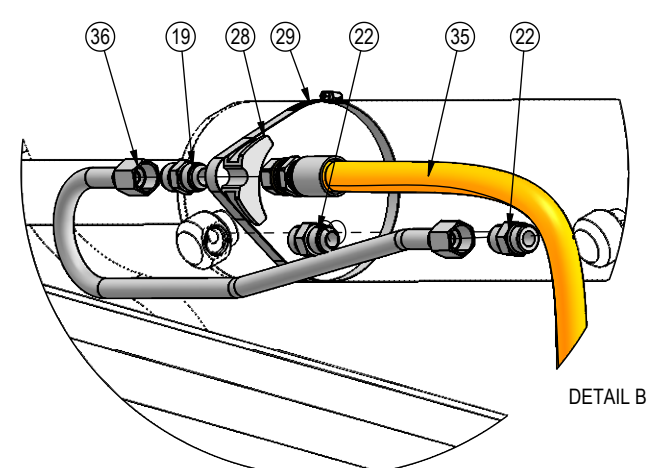
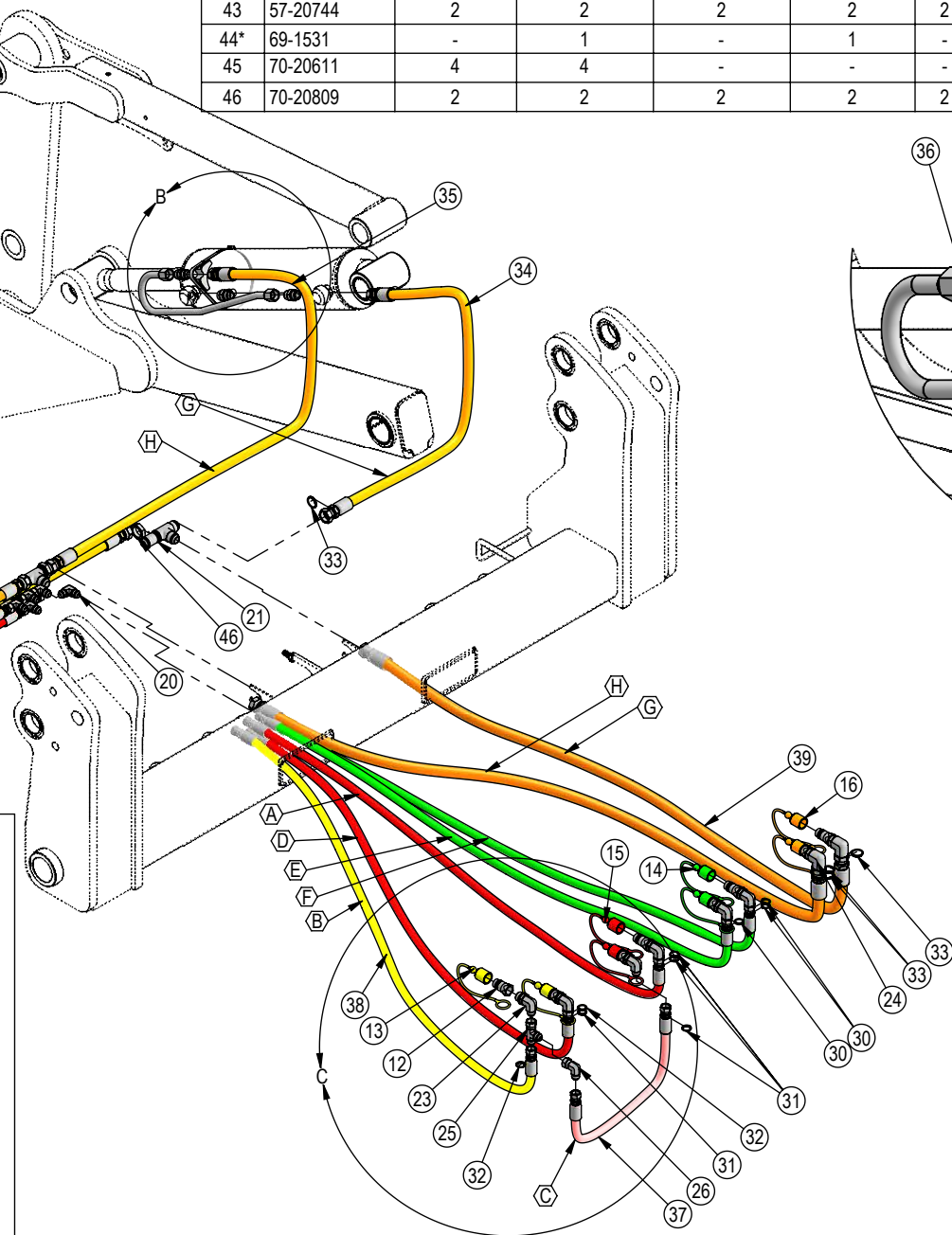

ITEM NO.	SINGLE CONTROL QTY.	DUAL CONTROL QTY.	PART NO.	DESCRIPTION
1	2	2	16-20124	1/2" x 1" Hex Bolt Gr 5 NC
2	2	2	16-812525	8mm x 1.25mm x 25mm Metric Hex Bolt Gr 10.9
3	1	1	18-19995-R	Multi-Coupler Mount
4	-	1	25-19864	Multi-Coupling Plate - 4 Port Fixed
5	-	1	25-19867	Multi-Coupling Plate - 4 Port - Cap
6	1	-	25-19868	Multi-Coupling Plate - 2 Port - Fixed
7	1	-	25-19871	Multi-Coupling Plate - 2 Port - Cap
8	2	4	25-19870	Multi-Coupling Plate - Male Coupler
9	2	2	25-3403	Pioneer Dust Cap Slider (Blue) (Left Cylinder)
10	-	2	25-3405	Pioneer Dust Cap Slider (Brown) (Right Cylinder)
11	2	4	25-34342	Tappet Quick Coupler Male - Poppet Style
12	2	4	25-40407	Multi-Coupling Plate - Snap Ring
13	2	4	31-15199-8-8	JIC Union Elbow 90°
14A,B	2	4	31-34051	Straight Thread Elbow 90° JIC x O-Ring
14C	2	4	31-6802-08-10	Straight Thread Elbow 45° JIC x O-Ring
15	2	4	31-34150	Straight Thread Elbow 45° JIC x O-Ring
16	9	9	34-18888-BL	-12 Blue - Spiral Band
17	-	9	34-18888-BR	-12 Brown - Spiral Band
18A,C	2	4	35-30183	293" (24.42") x 1/2" -8JIC/-8JIC Hose W/ Cordura
18B	2	4	35-18953-3200	320" (26.67") x 1/2" -8JIC/-8JIC Hose W/ Cordura
19	2	2	35-31135	78" x 1/2" -8JIC/-8JIC Hose W/Cordura
20	-	2	35-31136	81" x 1/2" -8JIC/-8JIC Hose W/Cordura
21	2	2	57-20741	5/16" Flat Washer
22	2	2	57-20744	1/2" Flat Washer

Hoses Not Drawn to Scale

Item A for CNH, JD 9R, JD 9030

Item B for Versatile, Challenger MT900 and JD 9RX

Item C for Claas Xerion

Every hydraulic function from the front to the back of the system is designated by a  $\odot$  and a letter and can also be referenced on the Hydraulic Schematic on Page 46.

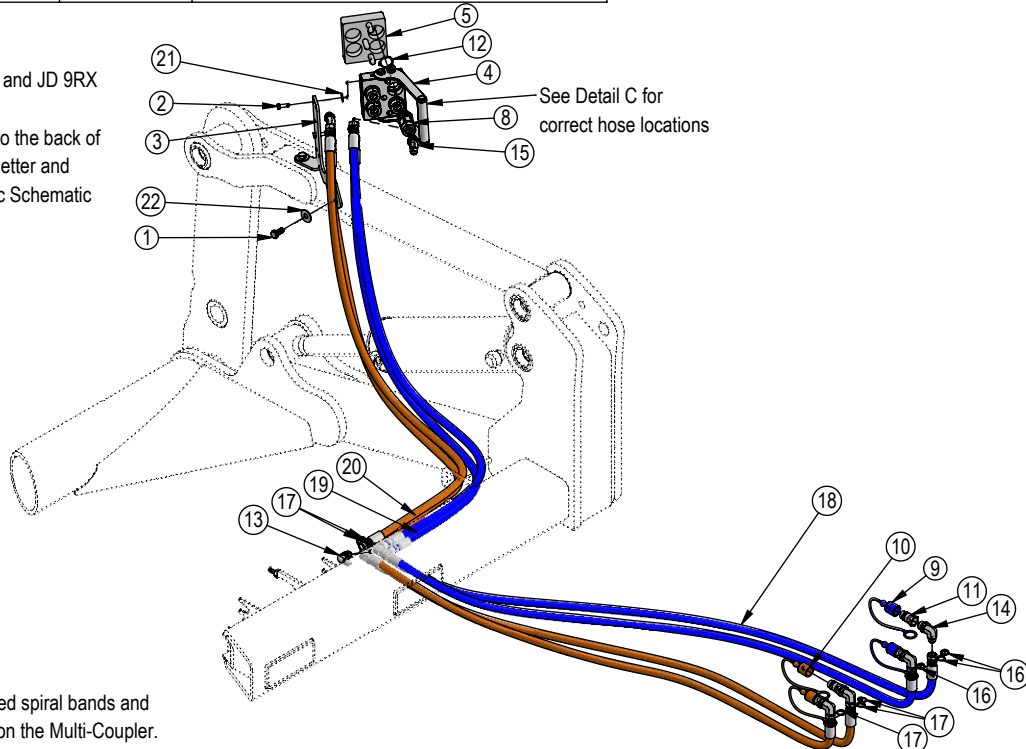

NOTE: All hoses are marked with colored spiral bands and should be attached to designated ports on the Multi-Coupler.

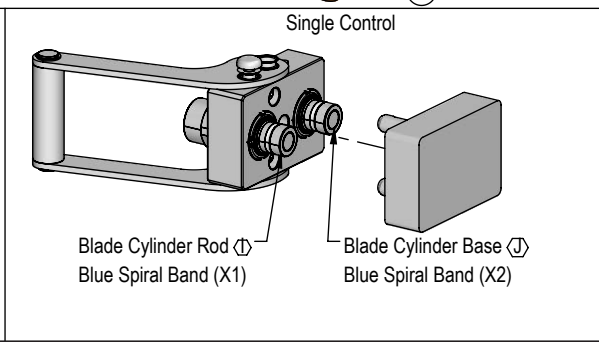
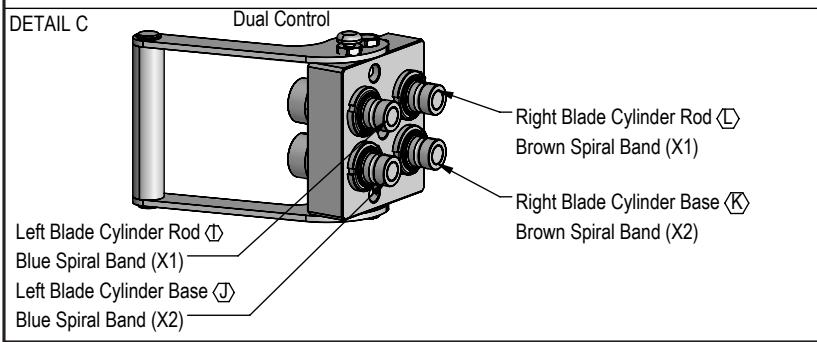

ITEM NO.	PART NO.	HAHT Electric QTY.	HANT 2-Stick QTY.	HANT Electric QTY.	NAHT QTY.	DESCRIPTION
1	16-812525	2	2	2	2	8mm x 1.25mm x 25mm Metric Hex Bolt Gr 10.9
2	25-19864	1	1	-	-	Multi-Coupling Plate - 4 Port Fixed
3	25-19867	1	1	-	-	Multi-Coupling Plate - 4 Port - Cap
4	25-19868	-	-	1	1	Multi-Coupling Plate - 2 Port - Fixed
5	25-19871	-	-	1	1	Multi-Coupling Plate - 2 Port - Cap
6	57-20741	2	2	2	2	5/16" Flat Washer

**HAHT Electric**

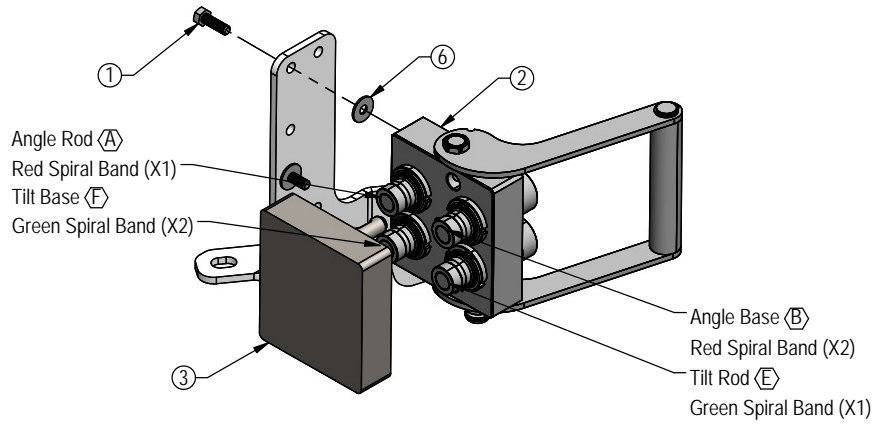

**HANT 2-Stick**

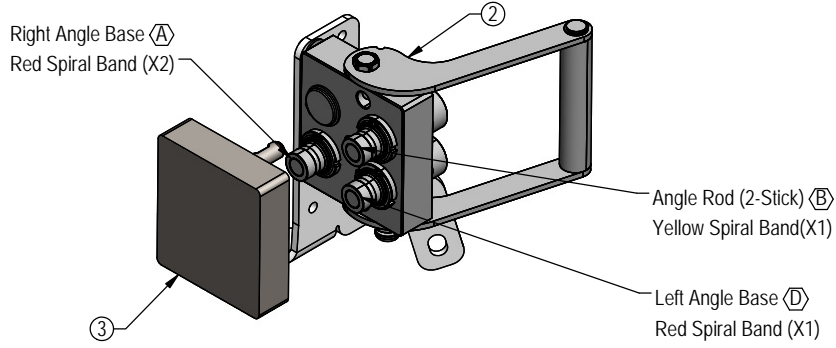

**HANT Electric**

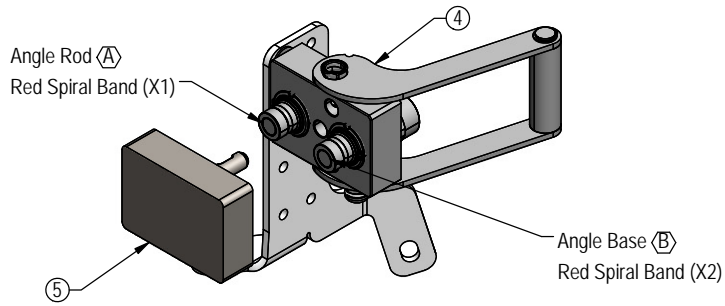

**NAHT**

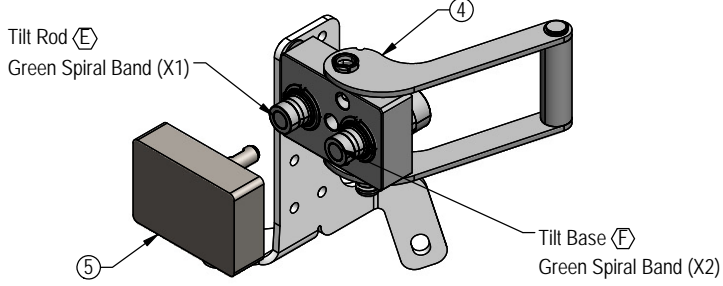

Prior to operating the blade system, all air must be purged from the hydraulic system. Follow the steps below for each function on your blade.

**Lift Function:**

1. With the lift frame down and blocked, loosen the fittings on both ends of the lift cylinders.
2. Actuate the raise function to supply oil to the rod end of the cylinders.
3. When oil starts to flow from the fittings, stop oil flow, and tighten the fitting on the rod end of the lift cylinders.
4. Continue to flow oil until the system is fully raised and then block the lift frame.
5. Actuate the function in the opposite direction to supply oil to the base end of the lift cylinders.
6. When all air is removed from the lift system, stop oil flow and tighten the fittings on the base end of the lift cylinders.
7. Raise lift system and remove blocks. Cycle up and down 5 more times.
8. Check tractor oil level and fill if necessary.
9. Continue with connecting the blade on Page 13.

**Blade Width Function:**

1. Loosen the fittings on the rod and base end of the right cylinder.
2. Actuate the blade width function to extend the right cylinder and supply oil to the base end of the right cylinder.
3. When oil starts to flow from the fittings, stop oil flow, and tighten the fitting on the base end of the right cylinder.
4. Fully extend the right cylinder.
5. Actuate the function in the opposite direction.
6. When oil starts to flow from the rod end fitting, stop oil flow, and tighten the remaining fittings on the cylinders.
7. Continue to actuate the cylinder until cylinder is fully retracted.
8. Cycle the right cylinder in and out 5 more times.
9. Repeat Steps 1-8 for the left cylinder
10. Check tractor oil level and fill if necessary.

**Tilt Function:**

1. Use a lift or jack to tilt the blade system until the left side is fully up, loosen the fittings on the rod and base end of both tilt cylinders.
2. Actuate the tilt function to extend the right tilt cylinder and supply oil to the base end of the right cylinder and to the rod end of the left cylinder.
3. When oil starts to flow from the fittings, stop oil flow, and tighten the fitting on the base end of the right cylinder and rod end of the left cylinder.
4. Remove the lift or jack.
5. Continue to actuate the tilt function until oil flows out of the remaining open ports.
6. Actuate the tilt function in the opposite direction.
7. When all air is removed from the tilt system, stop oil flow, and tighten the remaining fittings on the cylinders.
8. Cycle both cylinders in and out 5 more times.
9. Check tractor oil level and fill if necessary.

**Angle Function:**

1. Loosen the fittings on the rod and base end of the left angle cylinder.
2. Actuate the angle function to extend the left angle cylinder and supply oil to the base end of the left cylinder.
3. When oil starts to flow from the fittings, stop oil flow, and tighten the fitting on the base end of the left cylinder.
4. Continue to actuate the left angle function in the same direction until the cylinder is fully extended.
5. Actuate the left angle function in the opposite direction.
6. When oil starts to flow from the rod end fitting, stop oil flow, and tighten the rod end fitting on the left angle cylinder.
7. Continue to actuate the left angle function until cylinder is fully retracted.
8. Loosen the fittings on the rod and base end of the right angle cylinder.
9. Actuate the angle function to extend the right angle cylinder and supply oil to the base end of the right cylinder.
10. When oil starts to flow from the fittings, stop oil flow, and tighten the fitting on the base end of the right cylinder.
11. Continue to actuate the right angle function in the same direction until the cylinder is fully extended.
12. Actuate the right angle function in the opposite direction.
13. When oil starts to flow from the rod end fitting, stop oil flow, and tighten the rod end fitting on the right angle cylinder.
14. Continue to actuate the right angle function until cylinder is fully retracted.
16. Cycle the left cylinder in and out 5 more times and then the right cylinder in and out 5 more times.
16. Check tractor oil level and fill if necessary.

Run the blade through all the functions. If any function does not operate correctly, refer to corresponding section above and re-bleed. If problem still persists, call Grouser Products.

**To Connect:**

**Note:** If necessary, use a spotter to help center the blade on the lift system.

1. If necessary, lift the locking latch and pull the quick attach lock handle on the left side of the lift system to open the quick attach system. Refer to Page #18-19 for further clarification on the quick attach system.
2. Drive the tractor forward slowly until the top edge of the male quick attach is under the top hook of the female quick attach on the blade assembly.
3. Raise the lift system until the male quick attach engages the female hook. If both sides don't fully engage, reposition. Continue to raise the lift system until the blade is off the ground and the female quick attaches are against the front of the male quick attaches.
4. Shut off the tractor engine and set the parking brake.
5. Push the quick attach lock handle to engage the quick attach pins and lift the locking latch to lock the handle in place.
6. Clean and connect hydraulic multi-coupler on the top arm. Refer to Pages 42-43 for cleaning and connecting information.
7. If initial startup, refer to Page 12 before operating any function of the blade.

**To Disconnect:**

1. Lower the blade until the cutting edge is off the ground a few inches.
2. Shut off the tractor engine and set the parking brake.
3. Unhook the multi-coupler on the top arm.
4. Remove the multi-coupler covers from the parking stations on the blade assembly and install on the multi-couplers on the top arms.
5. Plug the blade side multi-couplers into the parking station.
6. Lift the locking latch and pull the quick attach lock handle to disengage the quick attach pins.
7. Start tractor, disengage the parking brake, and lower the blade until cutting edge is on the ground.
8. Continue to slowly lower the lift system to disengage the blade.
9. Slowly back away from the blade. When lift system is clear from the blade, raise the lift system.
10. Shut off the tractor engine and set the parking brake.

With the 2-Stick Hydraulic Angle Option, you will have the ability to angle the blade 30 degrees left or right. To achieve these angles, the two cylinders are designed to operate independently of each other with the use of 2 tractor hydraulic control levers and a safety relief valve. To angle the blade to the left or right, actuate the tractor hydraulic control lever corresponding to the left or right cylinder.

To ensure proper use and life of equipment, it is recommended to have both cylinders closed for straight ahead dozing and only one cylinder partially or fully extended for angled dozing as shown in the diagrams below. If the angle system is not used correctly, frame damage may occur. Diagrams below may look slightly different than your system, but the information is still compatible and important to your system.

**CAUTION:** Do not bypass the safety relief valve and plumb each cylinder to separate valves on the tractor.

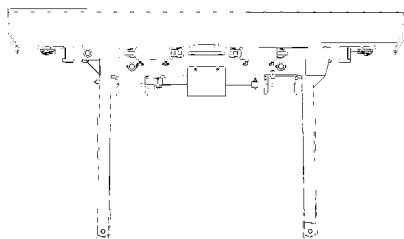
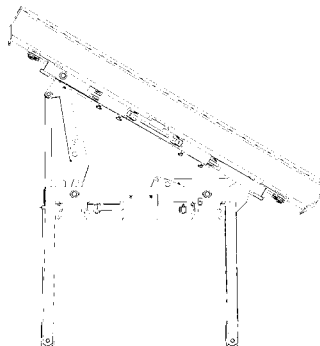
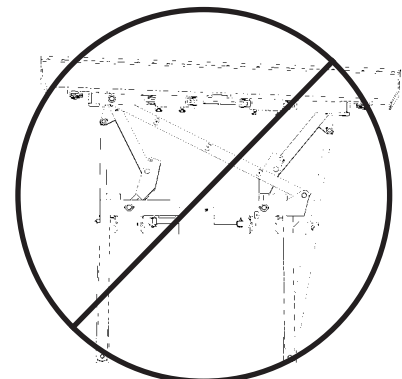
**CORRECT****CORRECT**  
(Left or Right)**Incorrect**

THE INFORMATION CONTAINED IN THIS DRAWING IS THE SOLE PROPERTY OF GROUSER PRODUCTS INC. ANY REPRODUCTION IN PART OR WHOLE WITHOUT THE WRITTEN PERMISSION OF GROUSER PRODUCTS INC. IS PROHIBITED.

**Instructions:**

1. Remove the male quick coupler from the SCV - UP which should be from the Rod End of the Lift Cylinder.
2. Remove the hose from the 90° fitting installed into the male quick coupler removed in Step #1.
3. Install the -12 male pipe x -12 female JIC Swivel fitting into the end of the control valve on the side the arrow is pointing to.
4. Attach the 90° fitting with the male quick coupler still attached to the JIC Swivel fitting that was installed in Step #3.
5. Install the -12 male pipe x -12 male JIC Straight fitting into the end of the control valve on the side opposite that the arrow is pointing to.
6. Attach the end of the original hose to the fitting attached in Step #5. See diagram below for further clarification on orientation of the control valve.
7. Plug male quick coupler back into the tractor
8. To adjust the control valve, unscrew the adjusting knob at the top of the valve. Run the lift cylinders up and down.
9. Adjust the lift speed by turning the adjusting knob back in with 1/2 turn increments.
10. After each 1/2 turn, run the lift cylinders up and down. Continue to do this until the desired speed is achieved and there is no chatter or cavitation.
11. After the control valve is adjusted, lock the adjusting knob with the lock screw.

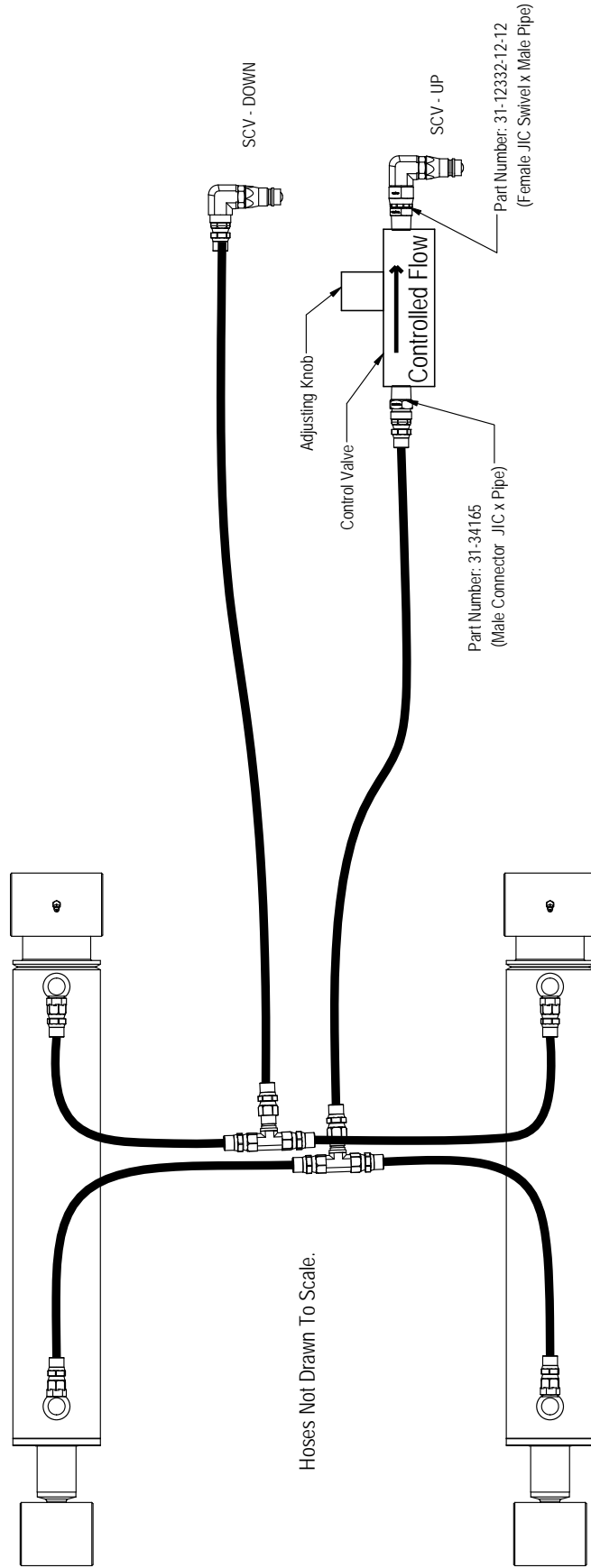

**GROUSER PRODUCTS INC.**  
 755 2nd Ave NW Phone 701.282.7710  
 West Fargo, ND 58078 Fax 701.282.8131  
 WWW.GROUSER.COM

TITLE: Lift System Speed Control Kit	
Date: 8/24/2016	DWG. NO.: 19699-INS

**Note:**  
 Your system may look slightly different from the diagram shown above but all lift systems are plumbed so that the rod end of both cylinders come to a t-fitting and then run to the back of the tractor and hook up to the SCV - UP.  
 The base end of both cylinders come to a t-fitting and then run to the back of the tractor and hook up to the SCV - DOWN.

### Skid Shoe Adjustment:

1. Remove the handle from the ratchet keeper by pulling the hitch clip pin and insert it into the handle receiver on the ratchet jack.
2. Loosen the locking nut on the ratchet jack.
3. Hold the body of the ratchet jack and rotate the ratchet jack handle to raise or lower the skid shoes.
4. If the skid shoe is not moving in the proper direction, flip the forward/reverse lever on the handle (see Figure 2). Rotate the ratchet jack handle again to move the skid shoe in the desired direction.
5. After the skid shoe is adjusted, rotate the ratchet jack handle until it rests against the ratchet keeper. Return the removable handle to the ratchet keeper ensuring that the ratchet jack handle is captured by the removable handle and the ratchet keeper. Secure the handle to the ratchet keeper with the hitch clip pin.
6. Tighten the locking nut against the ratchet jack body to keep it from moving.
7. When skid shoes are worn up to the bolt heads, replace skid shoes.

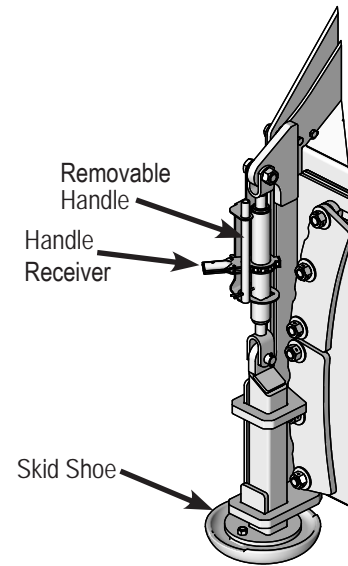

Figure 1

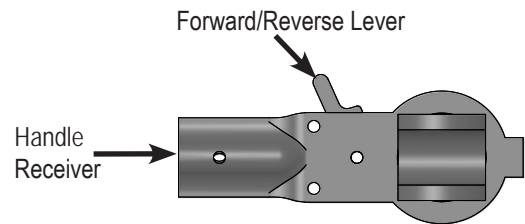

Figure 2

### Preferred Method:

1. The preferred blade position for adjusting the tilt plates is laying face down on blocks.
2. Remove the 6 nuts from the right tilt plates.
3. Remove skid shoe mounts to obtain better access to the bottom nuts.
4. Add or remove washers as needed to adjust tilt-way clearance to 1/16" - 1/8".
5. Reinstall the nuts in the right tilt plates.
6. Follow Steps #2-5 for the left tilt plates.
7. Once the tilt-way clearance is set, torque bolts to 640 ft-lbs.

### Non-Preferred Method:

**Note:** Do not remove all of the bolts at the same time if the blade is not laying face down.

1. The non-preferred blade position for adjusting the tilt plates is the blade in the upright position.
2. Remove the skid shoe mounts to obtain better access to bottom tilt plate nuts.
3. Remove the 3 nuts from the top right tilt plate and the bottom left tilt plate..
4. Add or remove washers as needed to adjust tilt-way clearance to 1/16" - 1/8".
5. Reinstall the nuts in the top right tilt plate and the bottom left tilt plate.
6. Follow Steps #2-5 for the bottom right tilt plate and the top left tilt plate.
7. Once the tilt-way clearance is set, torque bolts to 640 ft-lbs.

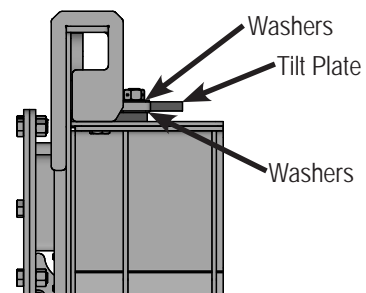

# Ag Pro - 12-20 Blade

ITEM NO.	QTY.	PART NO.	DESCRIPTION
1	1	15-16855-L	12-20 Blade End Weld, Left
2	1	15-16855-R	12-20 Blade End Weld, Right
3	1	15-17570	XAXT Blade Weld
4	12	16-16305	3/8" x 1.25" Flanged Elevator Bolt
5	2	16-18945	1" x 3" Hex Bolt Gr 5 NC - Short Thread
6	4	16-20517	3/4" X 4-1/2" Hex Bolt Gr. 8 NC
7	18	16-20538	7/8" x 2" Hex Bolt Gr 8 NC
8	3	16-20558	1" x 2" Hex Bolt Gr. 8 NC
9	8	16-20561	1" x 2-3/4" Hex Bolt Gr.8 NC
10	4	16-20563	1" x 3-1/4" Hex Bolt Gr.8 NC
11	10	16-21064	3/8" x 1" Carriage Bolt Gr 5 NC
12	4	16-21666	5/8" x 1-3/4" Plow Bolt Gr 5 NC
13	42	16-21748	3/4" X 2" Plow Bolt Gr 8 NC
14	1	18-16304-L	Bracket, Left Location
15	1	18-16304-R	Bracket, Right Location
16	1	18-18498-L	Ratchet Keeper - Left
17	1	18-18498-R	Ratchet Keeper - Right
18	2	19-7774	1" x 1" Spring Bushing
19	1	27-15598	Decal, AG PRO 12-20
20	1	27-15612-L	Ag Pro 12-20 Width Decal - 6-10 (Left Side)
21	1	27-15612-R	Ag Pro 12-20 Width Decal - 10-6 (Right Side)
22	1	27-40962	Warning Prop 65 Decal
23	1	NA	Grouser Dozer Metal Serial Tag
24	3	29-11118-5	5' - 3/4"x 8" Cutting Edge
25	1	29-11118-6	6' - 3/4"x 8" Cutting Edge
26	6	34-16158	Bearing, 2.625 x 6.00 W/Holes
27	2	34-16419	Top Seal
28	1	34-16420	8" Tube Seal
29	1	34-16421	10" Tube Seal
30	8	34-16425	Top Narrow UHMW
31	8	34-16426	Top Wide UHMW
32	4	34-16427	8" Inner UHMW
33	4	34-16428	8" Outer UHMW
34	8	34-16429	10" UHMW
35	2	34-17565	Skid Shoe Ratchet Jack
36	2	34-17567	Handle, Ratchet Jack
37	2	43-18463	1" x 2.75" Pin
38	2	43-18943	3/16" x 1-1/2" Cotter Pin
39	2	43-7767	Cylinder Pin Clip

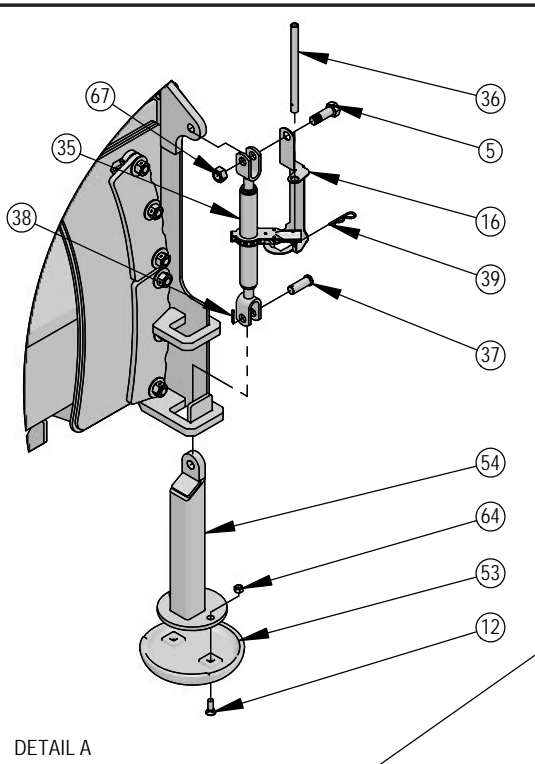

DETAIL A

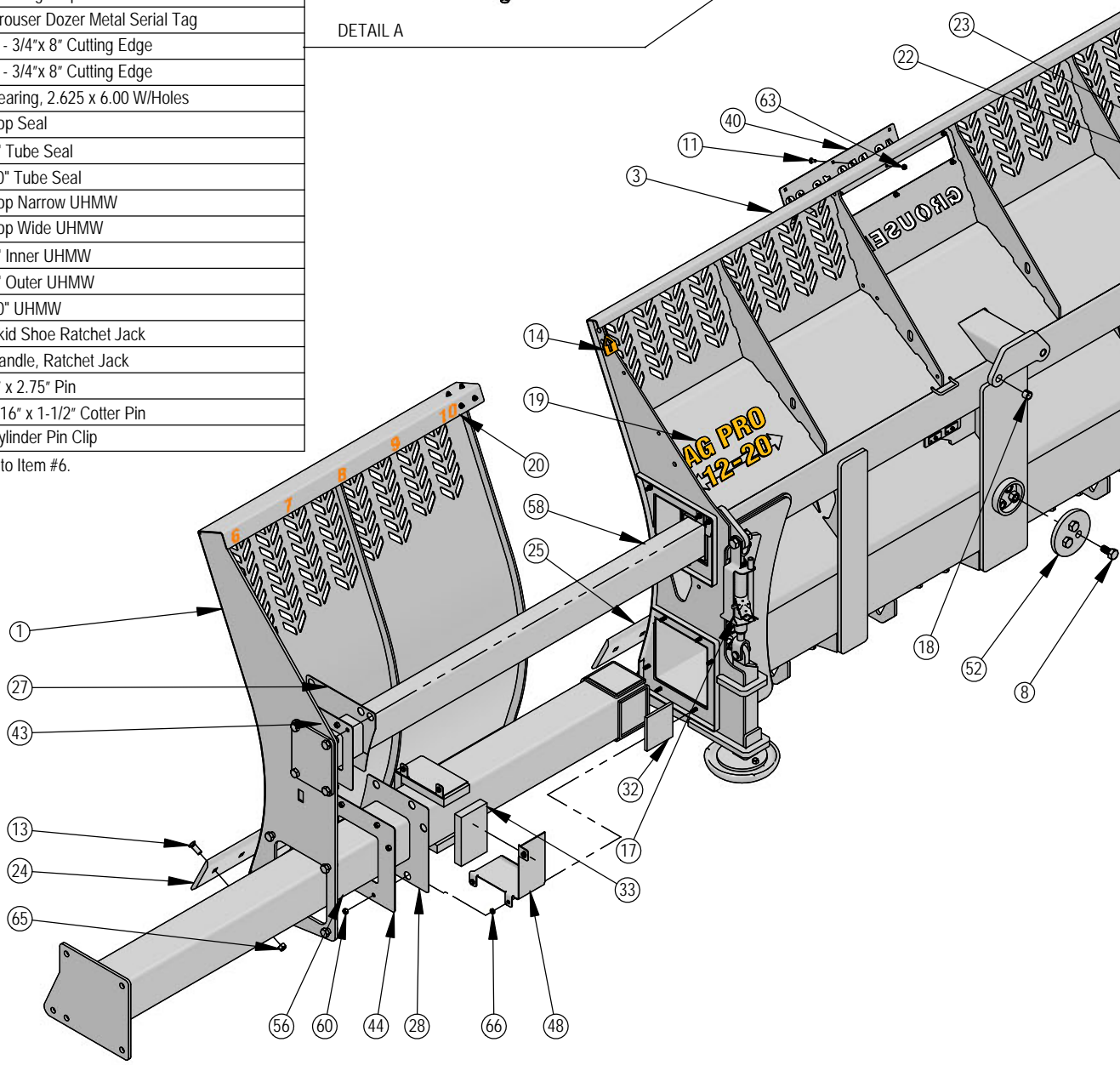

NOTE: Apply Blue Loctite to Item #6.  
 \* Part Not Shown



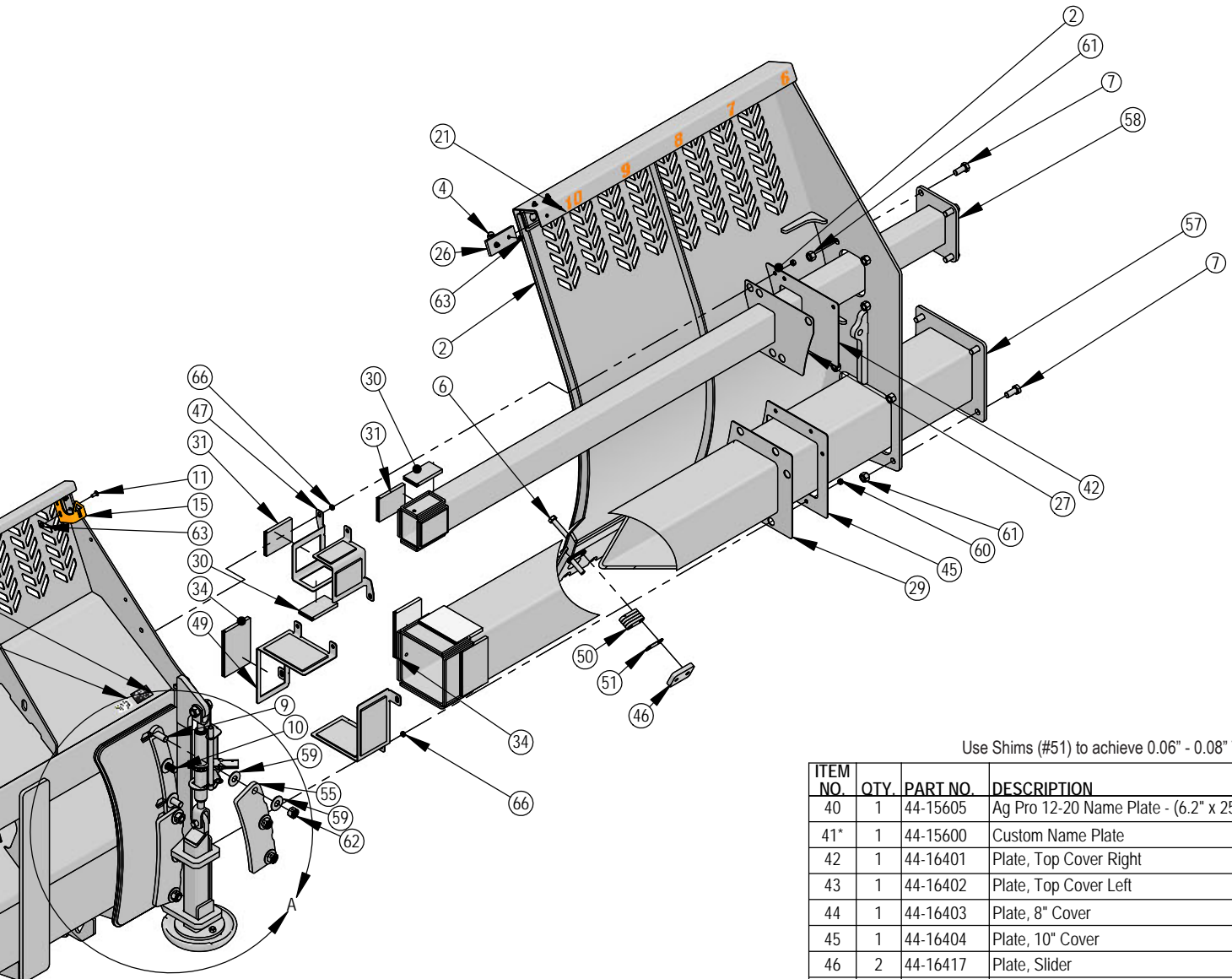

Use Shims (#51) to achieve 0.06" - 0.08" Tolerance

ITEM NO.	QTY.	PART NO.	DESCRIPTION
40	1	44-15605	Ag Pro 12-20 Name Plate - (6.2" x 25.6")
41*	1	44-15600	Custom Name Plate
42	1	44-16401	Plate, Top Cover Right
43	1	44-16402	Plate, Top Cover Left
44	1	44-16403	Plate, 8" Cover
45	1	44-16404	Plate, 10" Cover
46	2	44-16417	Plate, Slider
47	4	44-16422	Top Outer Retainer
48	2	44-16423	8" Outer Retainer
49	2	44-16424	10" Outer Retainer
50	2	44-16525	Standoff
51	12	44-16977	Plate, Slider Standoff Shim
52	1	44-3749	Backdrag Brace Plate
53	2	50-15458	12" Round Mushroom Skid Shoe
54	2	50-18775	Slider Skid Shoe Weld
55	4	52-18299	Tilt Plate
56	1	53-16408	8 x 8 Tube Weld
57	1	53-16410	10 x 10 Tube Weld
58	2	53-16990	4 x 6 Tube Weld
59	24	57-20749	1" Flat Washer
60	22	70-20584	1/2" Hex Nut Gr 5 NC
61	18	70-20598	7/8" Hex Nut Gr 8 NC
62	12	70-20609	1" Hex Center Lock Nut Gr.2 NC
63	22	70-20622	3/8" Flange Hex Nut Gr 5 NC
64	4	70-20646	5/8" Hex Top Lock Nut Gr 5 NC
65	42	70-20647	3/4" Hex Top Lock Nut Gr 5 NC
66	22	70-20804	1/2" Hex Jam Nut
67	2	70-20999	1" Hex Top Lock Nut Gr 8 NC (YZ)

DWG. NO.: 17570-A

# Hydraulic Angle-Hydraulic Tilt System

ITEM NO.	QTY.	PART NO.	DESCRIPTION
1	1	11-19670	Ag Pro Plus - Stabilizer Arm
2	1	11-19685	Angle Arm Assembly-R
3	1	11-19690	Angle Arm Assembly-L
4	1	11-40866	Bell Crank
5	1	16-20011	1/4" x 2-3/4" Hex Bolt Gr 5 NC
6	2	16-20130	1/2" x 2-1/2" Hex Bolt Gr 5 NC
7	4	16-20132	1/2" x 3" Hex Bolt Gr 8 NC
8	2	16-20424	1/2" x 3-1/2" Hex Bolt Gr 8 NC
9	3	16-20427	1/2" x 4-1/2" Hex Bolt Gr 8 NC
10	8	16-20560	1" x 2-1/2" Hex Bolt Gr 8 NC
11	2	16-21065	3/8" x 1-1/4" Carriage Bolt Gr 5 NC
12	4	16-21126	1/2" x 1-1/2" Carriage Bolt Gr 5 NC
13	2	19-40440	.378" ID x .503" OD x .375" Spacer
14	2	27-2409	Pinch Decal (Hand)
15	2	27-9503	Pinch Decal (Foot)
16	2	27-9504	Grouser Horizontal Decal

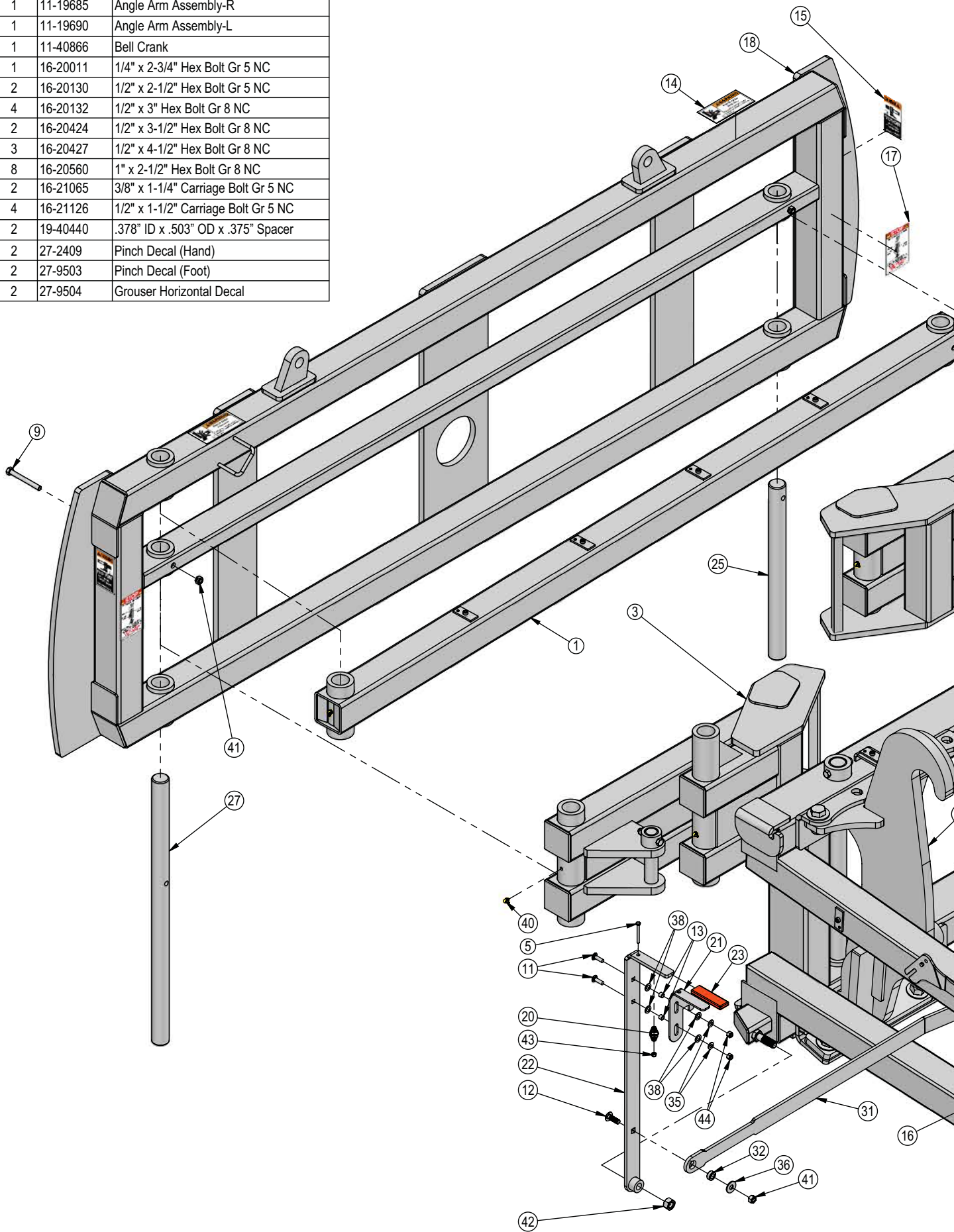

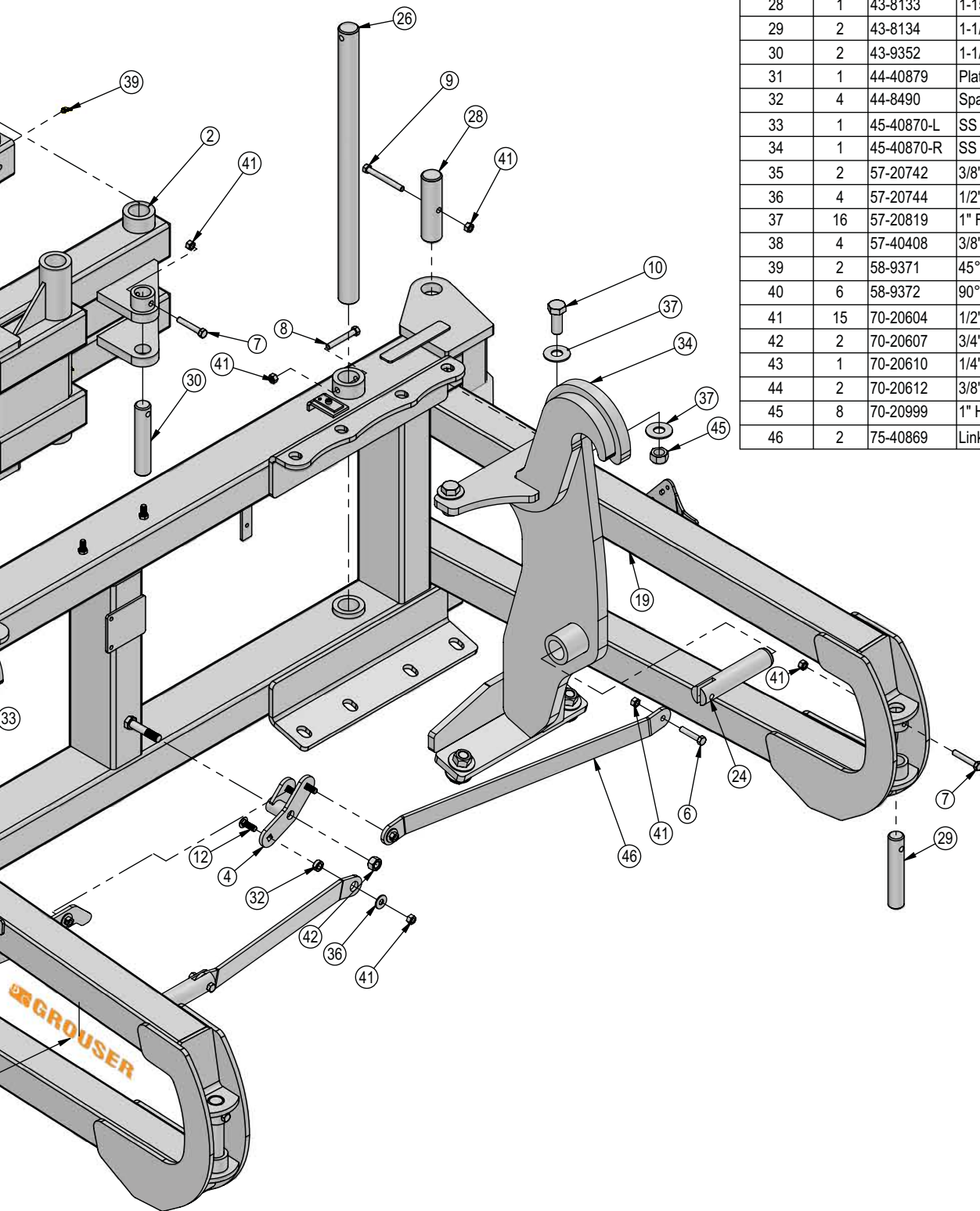

ITEM NO.	QTY.	PART NO.	DESCRIPTION
17	2	27-40917	Ratchet Holder Storage Decal
18	1	32-16975	Slider HA Tilt Frame
19	1	32-19675	Angle Frame
20	1	34-17799	Latch Spring
21	1	39-14663	Latch
22	1	39-14665	Handle Weld
23	1	39-3072	Rubber Handle
24	2	43-18486	AG Pro SS QA Lock Pin
25	1	43-8130	1-15/16" X 23-1/4" NR Pin
26	2	43-8131	1-15/16" X 31" NR Pin
27	1	43-8132	1-15/16" X 35-1/2" NR Pin
28	1	43-8133	1-15/16" X 7-1/8" NR Pin
29	2	43-8134	1-1/2" x 8" NR Pin
30	2	43-9352	1-1/2" X 7-1/2" NR Pin
31	1	44-40879	Plate, Link
32	4	44-8490	Spacer
33	1	45-40870-L	SS Bolt in Quick Attach - Left
34	1	45-40870-R	SS Bolt in Quick Attach - Right
35	2	57-20742	3/8" Flat Washer
36	4	57-20744	1/2" Washer
37	16	57-20819	1" Flat Washer Heavy Duty Gr 8 (USS)
38	4	57-40408	3/8" Flat Nylon Washer
39	2	58-9371	45° 1/8" NPT Grease Fitting
40	6	58-9372	90° 1/8" NPT Grease Fitting
41	15	70-20604	1/2" Hex Center Lock Nut Gr 2 NC
42	2	70-20607	3/4" Center Lock Hex Nut Gr 2 NC
43	1	70-20610	1/4" Nyloc Hex Nut Gr 5 NC
44	2	70-20612	3/8" Nyloc Hex Nut Gr 5 NC
45	8	70-20999	1" Hex Top Lock Nut Gr 8 NC (YZ)
46	2	75-40869	Link, Bell Crank To Pin

ITEM NO.	QTY.	PART NO.	DESCRIPTION
1	4	16-20034	5/16" x 1" Hex Bolt Gr 5 NC
2	4	16-20036	5/16" x 1-1/2" Hex Bolt Gr 5 NC
3	4	16-20037	5/16" x 2" Hex Bolt Gr 5 NC
4	4	16-20040	5/16" x 2-1/2" Hex Bolt Gr 5 NC
5	4	16-35C612	3/8" x 3/4" Flange Bolt
6	1	18-14695	Valve Bracket </td
7	4	18-15684	12-20 Hose Hold Down Plate
8	1	18-1701	Valve Cover </td
9	1	18-19311-02-P-062	Hose Clamp
10	7	18-19311-03-P-087	Hose Clamp
11	1	18-19312-02	Twin Cover Plate
12	5	18-19312-03	Twin Cover Plate
13	2	18-19313-03	Twin Stacking Bolt
14	2	18-19314-02	Twin Safety Plate
15	4	19-13577	NR Pin Spacer Clevis End
16	2	19-7774	1" x 1" Spring Bushing
17	1	25-18961	Multi-Coupling Plate - 5/6 Port Parking Station
18	1	25-19862	Multi-Coupling Plate - 5 Port - Mobile
19	5	25-19865	Multi-Coupling Plate - Coupler - Female
20	6	25-40407	Multi-Coupling Plate - Snap Ring
21	1	25-40413	Multi-Coupling Plate - Male Cap
22	2	26-34711	4 x 8 Hydraulic Cylinder
23	2	26-34725	4 x 43.5 Cylinder Tube Ends, Top Port

Note: Every hydraulic function from the front to the back of the system is designated by a letter and can also be referenced on the Hydraulic Schematic on Page 44.

DETAIL A

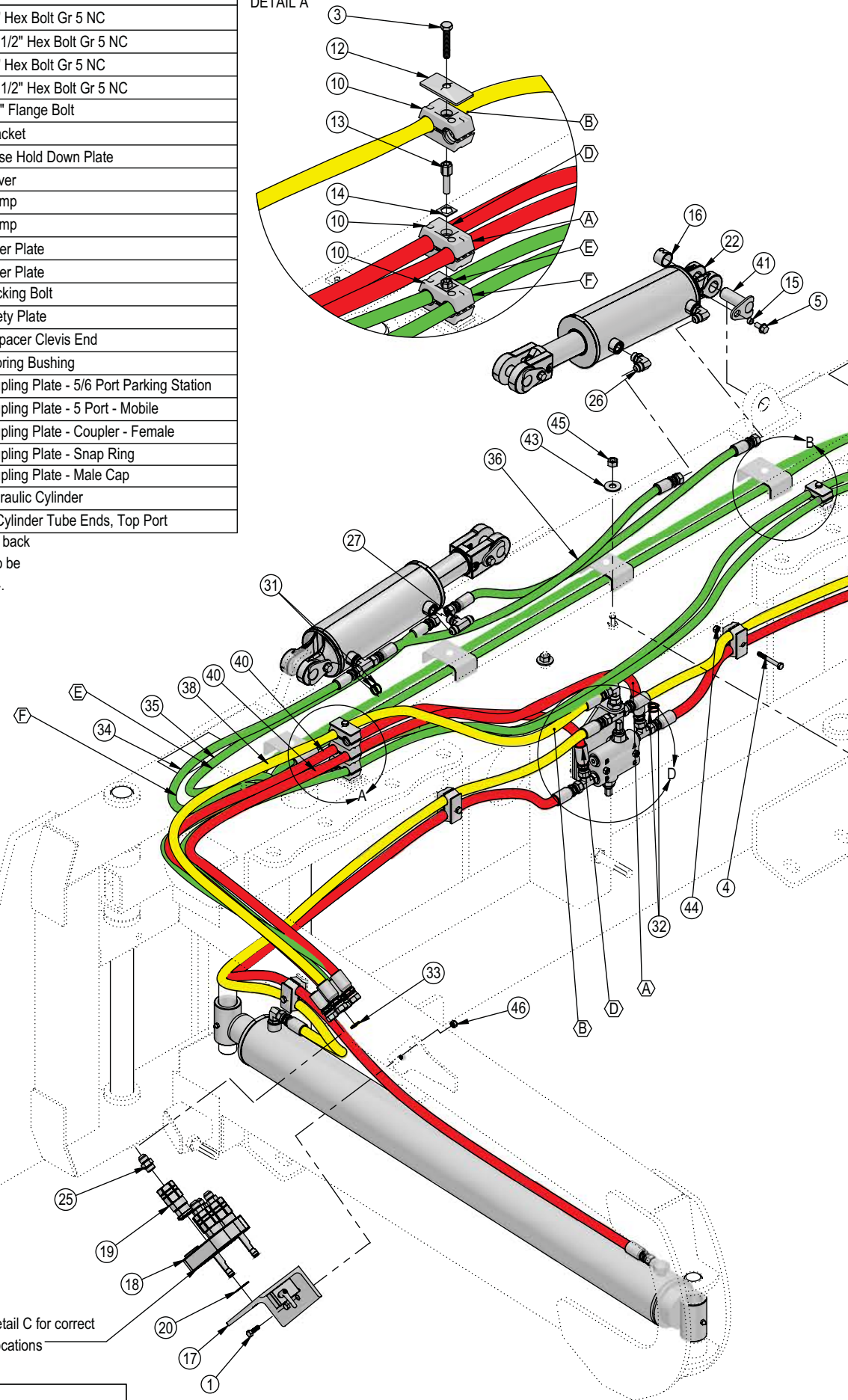

Note: The cylinder part number is stamped on the base end of the cylinder opposite of the hydraulic ports.

See Detail C for correct hose locations

No. On Cylinder	Part No.	Description
26-34711	49-12271	Seal Kit 4" (647135) Nitrided Rod - Clevis Ends
26-34725	49-12274	Seal Kit 4" (647210) Nitrided Rod - Tube Ends

ITEM NO.	QTY.	PART NO.	DESCRIPTION
24	1	31-34020	Bulkhead Branch Tee JIC
25	7	31-34040	Straight JIC x O-Ring
26	4	31-34050	Straight Thread Elbow 90° JIC x O-Ring
27	2	31-34060	Branch Tee JIC x O-Ring
28	2	31-34070	Run Tee JIC x O-Ring
29	1	31-34100	Swivel Nut Elbow 90° JIC
30	2	31-34123	Hex Socket O-Ring Plug
31	6	34-18888-GR	-12 Green - Spiral Band
32	6	34-18888-RD	-12 Red - Spiral Band
33	2	34-18888-YL	-12 Yellow - Spiral Band
34	1	35-11686-2120	212" x 3/8" -8JIC/-8JIC Hose
35	1	35-11686-2220	222" x 3/8" -8JIC/-8JIC Hose
36	2	35-30022	39" x 3/8" -8JIC/-8JIC Hose
37	2	35-30132	69" x 1/2" -8 JIC/-8 JIC Hose
38	1	35-30133	72" x 1/2" -8JIC/-8JIC Hose
39	2	35-30141	96" x 1/2" -8 JIC/-8 JIC Hose
40	2	35-30191	77" x 1/2" -8JIC/-8JIC Hose
41	4	43-13580	Pin Weld
42	1	56-7772	Relief Valve
43	2	57-20744	1/2" Washer
44	6	70-20581	5/16" Hex Nut Gr 5 NC
45	2	70-20604	1/2" Hex Center Lock Nut Gr 2 NC
46	2	70-20611	5/16" Nyloc Hex Nut Gr 5 NC
47	1	70-20807	3/4" Hex Jam Nut NF

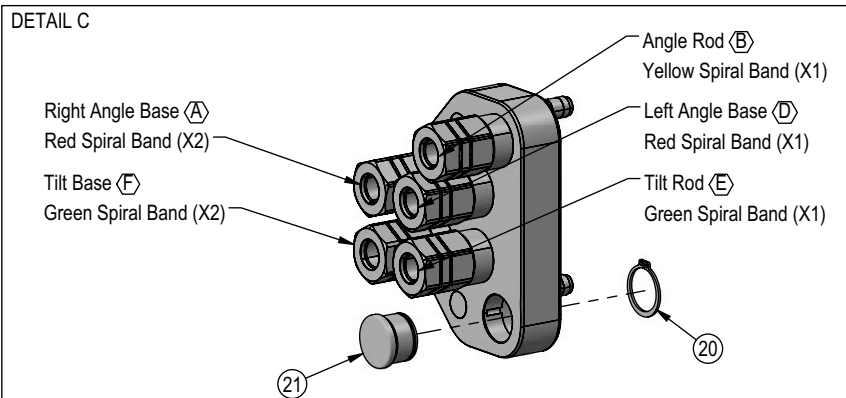
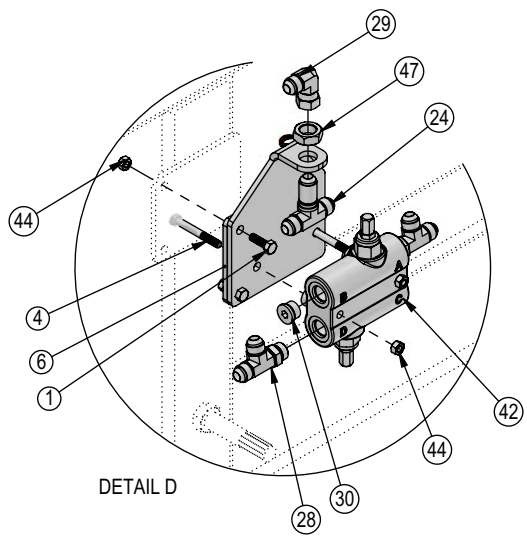
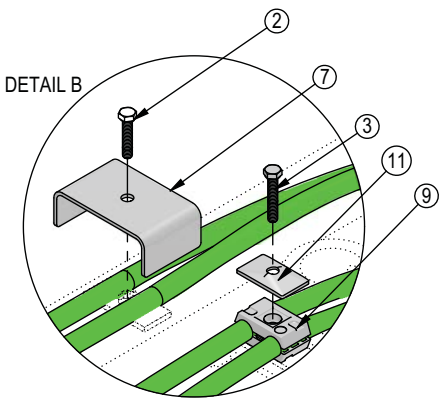
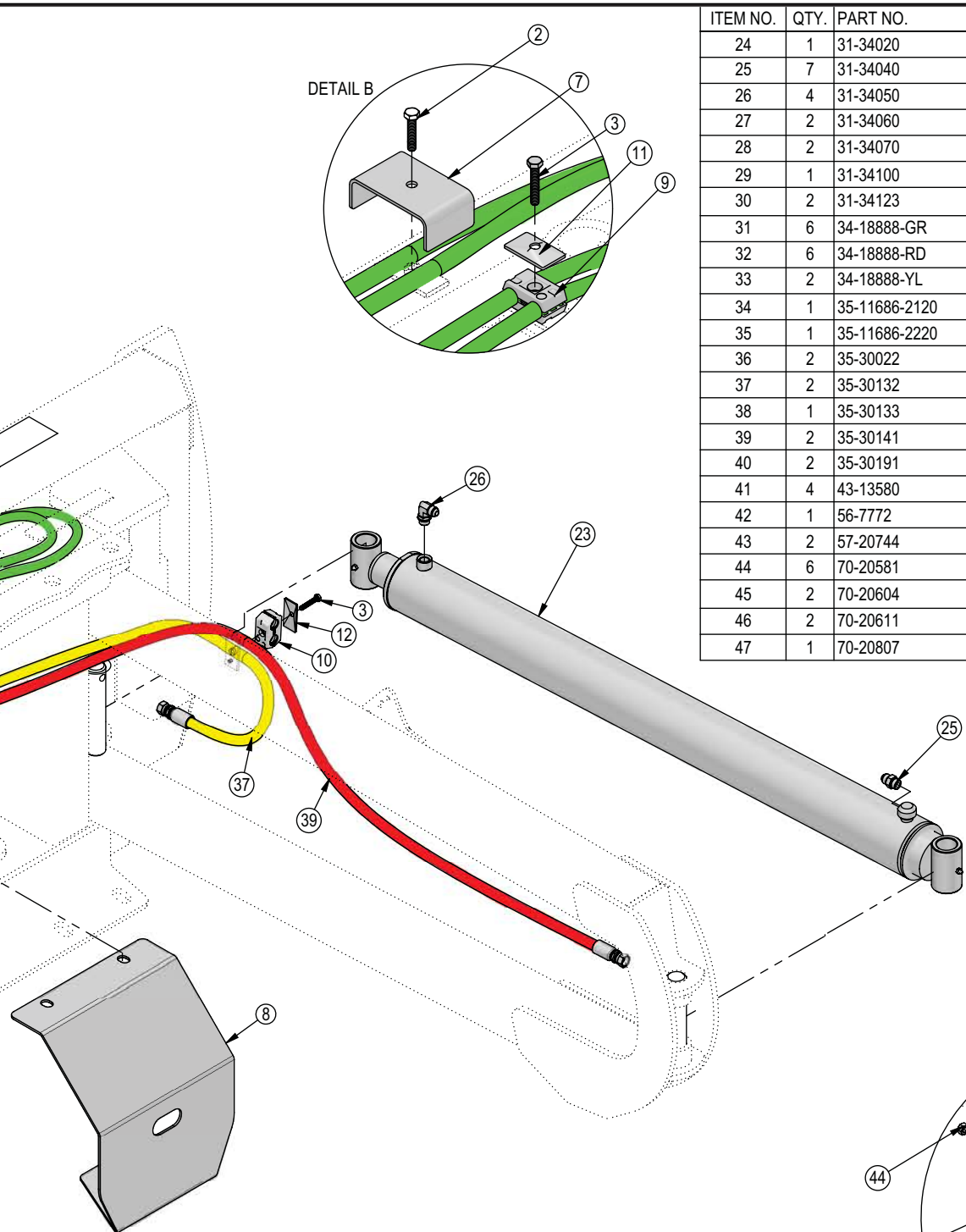

Note: View is from Multi-Coupler Installed on Top Arm.  
 All hoses are marked with colored spiral bands and should be attached to designated ports on the Multi-Coupler.

ITEM NO.	QTY.	PART NO.	DESCRIPTION
1	4	16-20035	5/16" x 1-1/4" Hex Bolt Gr 5 NC
2	4	16-20037	5/16" x 2" Hex Bolt Gr 5 NC
3	2	16-20040	5/16" x 2-1/2" Hex Bolt Gr 5 NC
4	2	16-20077	3/8" x 4-1/2" Hex Bolt Gr 5 NC
5	4	16-35C612	3/8" x 3/4" Flange Bolt
6	2	16-812525	8mm x 1.25mm x 25mm Metric Hex Bolt Gr 10.9
7	1	18-1701	Valve Cover
8	4	18-19311-02-P-062	Half Hose Clamp
9	1	18-19311-02-P-062	Hose Clamp
10	6	18-19311-03-P-087	Hose Clamp
11	5	18-19312-02	Twin Cover Plate
12	5	18-19312-03	Twin Cover Plate
13	1	18-19313-03	Twin Stacking Bolt
14	1	18-19314-02	Twin Safety Plate
15	4	19-13577	NR Pin Spacer Clevis End
16	2	19-7774	1" x 1" Spring Bushing
17	1	25-18956	Multi-Coupling Plate - 4 Port Parking Station
18	4	25-19865	Multi-Coupling - Female Coupler
19	1	25-19866	Multi-Coupling Plate - 4 Port Mobile
20	4	25-40407	Multi-Coupling - Snap Ring
21	2	26-34711	4 x 8 Hydraulic Cylinder
22	2	26-34725	4 x 43.5 Cylinder Tube Ends, Top Port

Note: Every hydraulic function from the front to the back of the system is designated by a  $\odot$  and a letter and can also be referenced on the Hydraulic Schematic on Page 45.

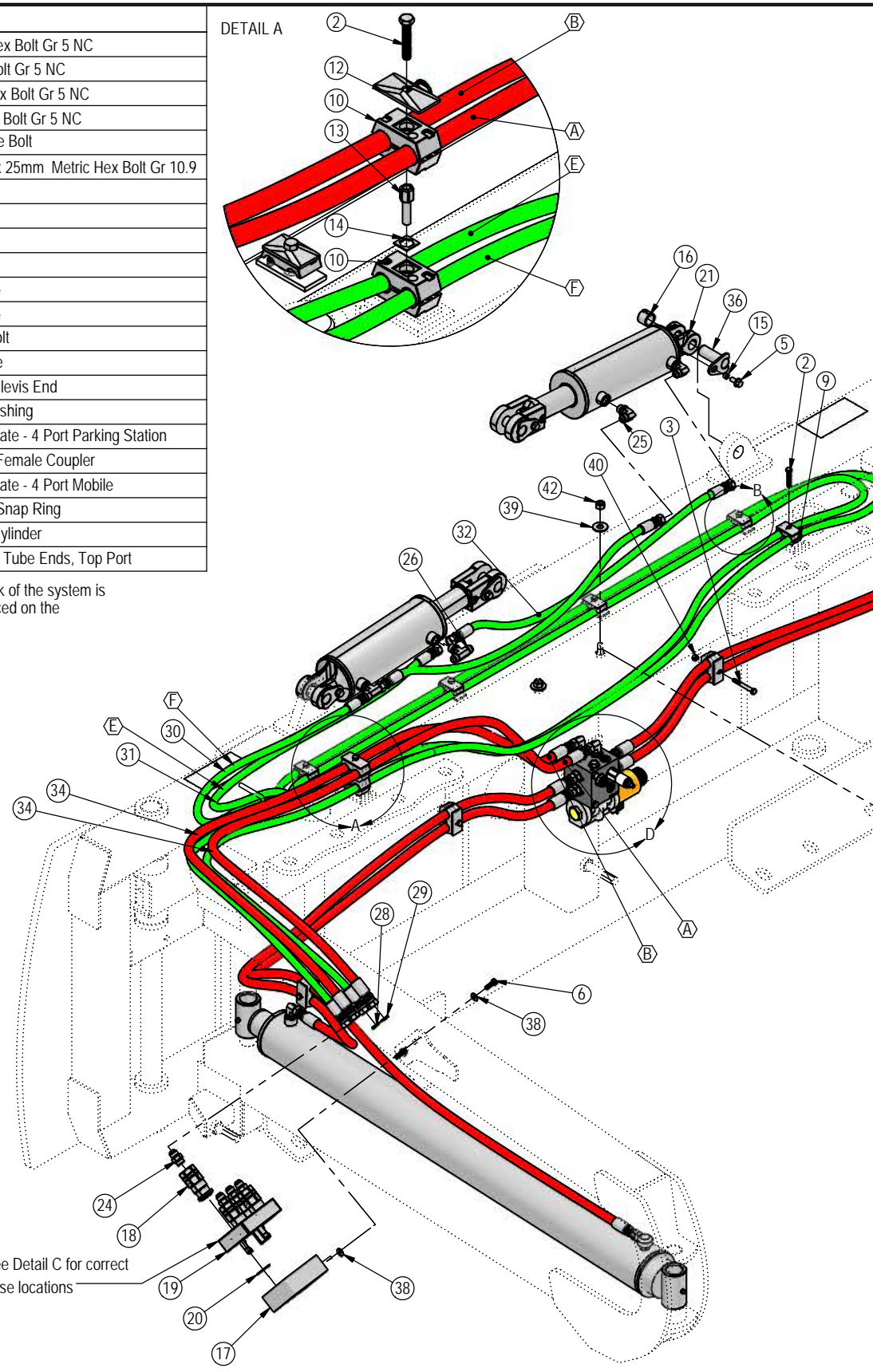

See Detail C for correct hose locations

Note: The cylinder part number is stamped on the base end of the cylinder opposite of the hydraulic ports.

No. On Cylinder	Part No.	Description
26-34711	49-12271	Seal Kit 4" (647135) Nitrided Rod - Clevis Ends
26-34725	49-12274	Seal Kit 4" (647210) Nitrided Rod - Tube Ends

ITEM NO.	QTY.	PART NO.	DESCRIPTION
23	1	31-13332	-6 SAE Breather Fitting
24	11	31-34040	Straight JIC x O-Ring
25	5	31-34050	Straight Thread Elbow 90° JIC x O-Ring
26	2	31-34060	Branch Tee JIC x O-Ring
27	1	31-34100	Swivel Nut Elbow 90° JIC
28	6	34-18888-GR	-12 Green - Spiral Band
29	6	34-18888-RD	-12 Red - Spiral Band
30	1	35-11686-2120	212" x 3/8" -8JIC/-8JIC Hose
31	1	35-11686-2220	222" x 3/8" -8JIC/-8JIC Hose
32	2	35-30022	39" x 3/8" -8JIC/-8JIC Hose
33	2	35-30132	69" x 1/2" -8 JIC/-8 JIC Hose
34	2	35-30133	77" x 1/2" -8JIC/-8JIC Hose
35	2	35-30141	96" x 1/2" -8 JIC/-8 JIC Hose
36	4	43-13580	Pin Weld
37	1	56-13305	Hydraulic Valve
38	4	57-20740	1/4" Flat Washer
39	2	57-20744	1/2" Washer
40	2	70-20581	5/16" Hex Nut Gr 5 NC
41	2	70-20582	3/8" Hex Nut Gr 5 NC
42	2	70-20604	1/2" Hex Center Lock Nut Gr 2 NC
43	1	68-40443	Valve System Relief Cartridge
44	1	68-18871	Valve Thermal Relief Cartridge
45	1	68-18873	Valve Solenoid Coil
46	1	68-18874	Valve Coil Nut and O-Ring
47	1	68-40466	Valve Control Center
48	1	68-40469	Valve Block

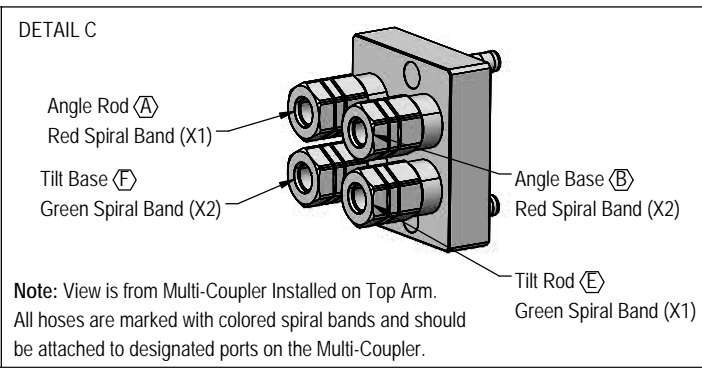
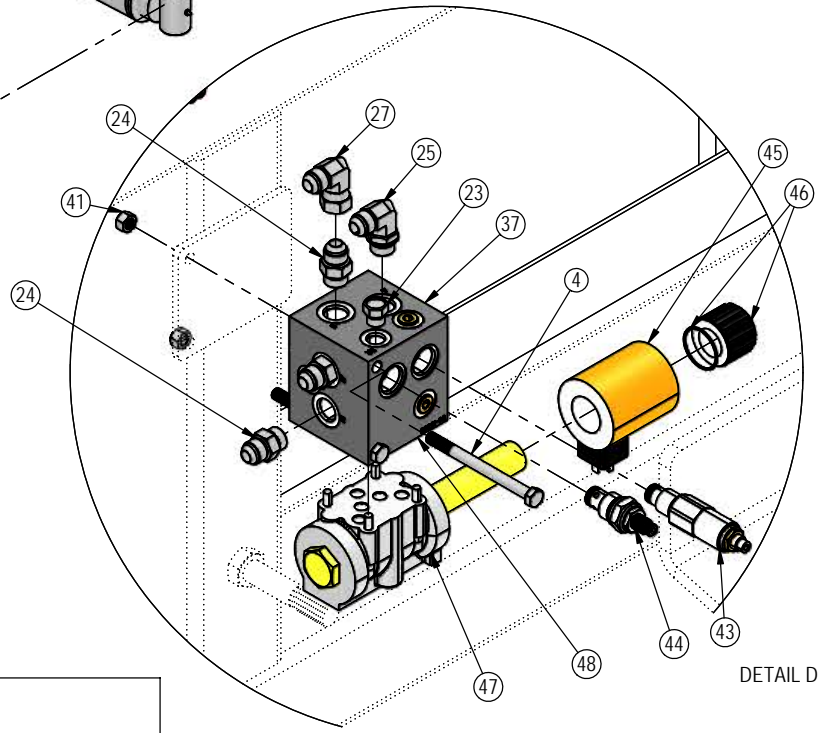
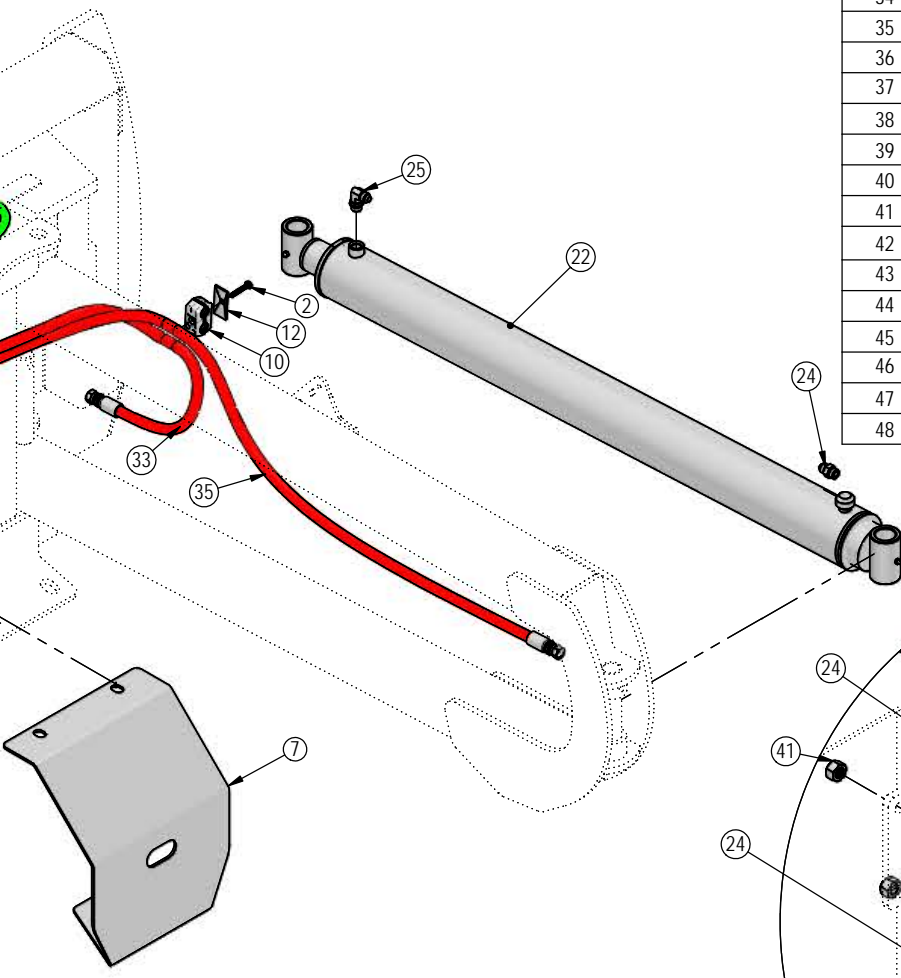
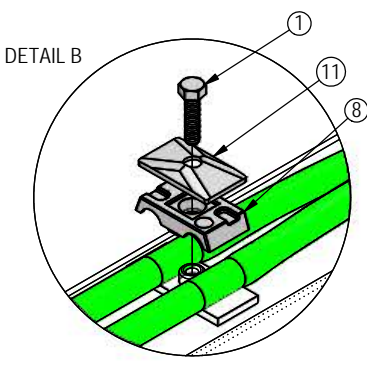

DWG. NO.: 40992

ITEM NO.	QTY.	PART NO.	DESCRIPTION
1	1	14-9366	Ag Pro Non Tilt Bar
2	2	16-20034	5/16" x 1" Hex Bolt Gr 5 NC
3	3	16-20037	5/16" x 2" Hex Bolt Gr 5 NC
4	4	16-20040	5/16" x 2-1/2" Hex Bolt Gr 5 NC
5	2	16-20564	1" x 3-1/2" Hex Bolt Gr.8 NC
6	2	16-812525	8mm x 1.25mm x 25mm Metric Hex Bolt Gr 10.9
7	1	18-14695	Valve Bracket </td
8	1	18-1701	Valve Cover
9	6	18-19311-03-P-087	Hose Clamp
10	5	18-19312-03	Twin Cover Plate
11	1	18-19313-03	Twin Stacking Bolt
12	1	18-19314-02	Twin Safety Plate
13	1	25-18956	Multi-Coupling Plate - 4 Port Parking Station
14	3	25-19865	Multi-Coupling - Female Coupler
15	1	25-19866	Multi-Coupling Plate - 4 Port Mobile
16	3	25-40407	Multi-Coupling - Snap Ring
17	1	25-40413	Multi-Coupling - Male Cap
18	2	26-34725	4 x 43.5 Cylinder Tube Ends, Top Port
19	1	31-34020	Bulkhead Branch Tee JIC

Note: Every hydraulic function from the front to the back of the system is designated by a ○ and a letter and can also be referenced on the Hydraulic Schematic on Page 44.

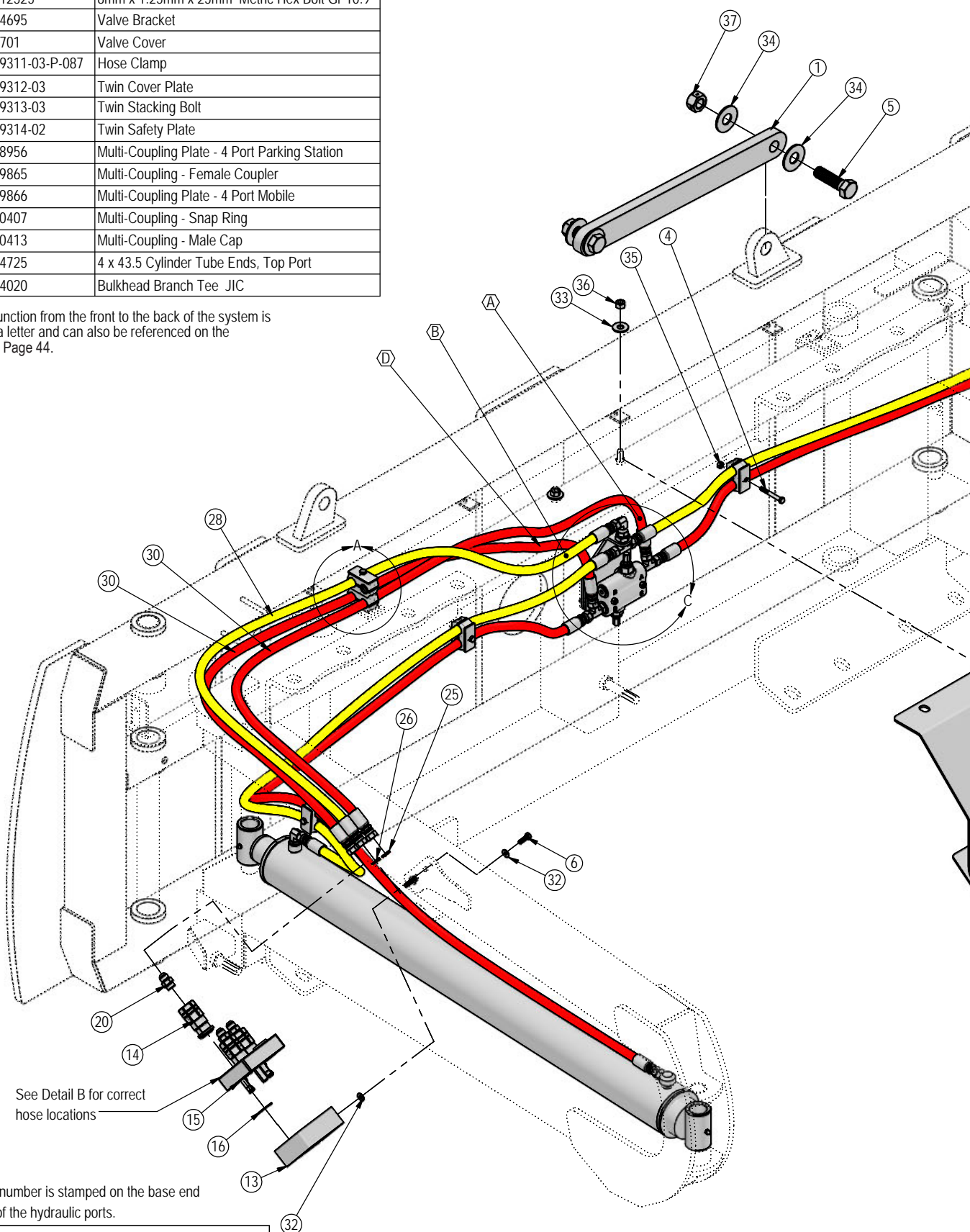

See Detail B for correct hose locations

Note: The cylinder part number is stamped on the base end of the cylinder opposite of the hydraulic ports.

No. On Cylinder	Part No.	Description
26-34725	49-12274	Seal Kit 4" (647210) Nitrided Rod - Tube Ends



ITEM NO.	QTY.	PART NO.	DESCRIPTION
20	5	31-34040	Straight JIC x O-Ring
21	2	31-34050	Straight Thread Elbow 90° JIC x O-Ring
22	2	31-34070	Run Tee JIC x O-Ring
23	1	31-34100	Swivel Nut Elbow 90° JIC
24	2	31-34123	Hex Socket O-Ring Plug
25	6	34-18888-RD	-12 Red - Spiral Band
26	2	34-18888-YL	-12 Yellow - Spiral Band
27	2	35-30132	69" x 1/2" -8 JIC/-8 JIC Hose
28	1	35-30133	72" x 1/2" -8JIC/-8JIC Hose
29	2	35-30141	96" x 1/2" -8 JIC/-8 JIC Hose
30	2	35-30191	77" x 1/2" -8JIC/-8JIC Hose
31	1	56-7772	Relief Valve
32	4	57-20740	1/4" Flat Washer
33	2	57-20744	1/2" Washer
34	4	57-20749	1" Flat Washer
35	6	70-20581	5/16" Hex Nut Gr 5 NC
36	11	70-20604	1/2" Hex Center Lock Nut Gr 2 NC
37	2	70-20609	1" Hex Center Lock Nut Gr.2 NC
38	1	70-20807	3/4" Hex Jam Nut NF

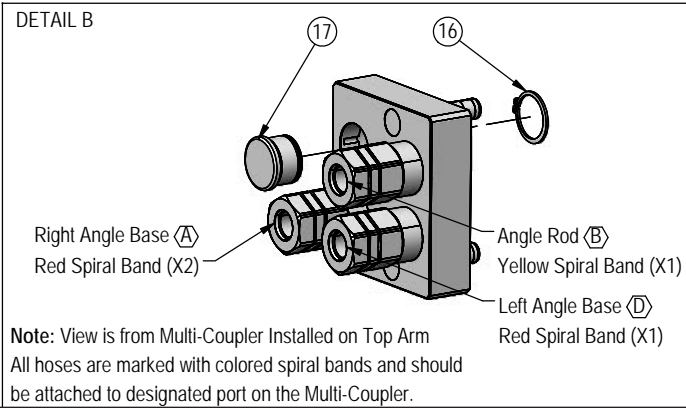
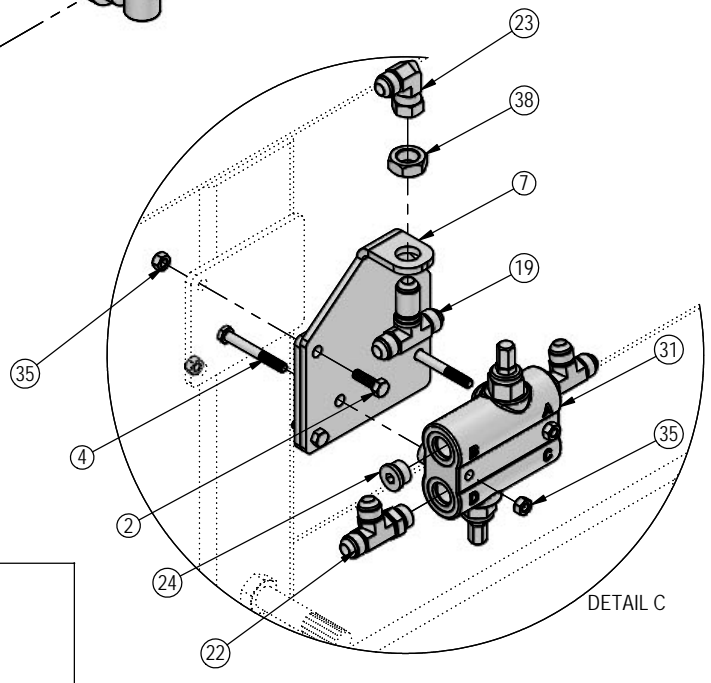
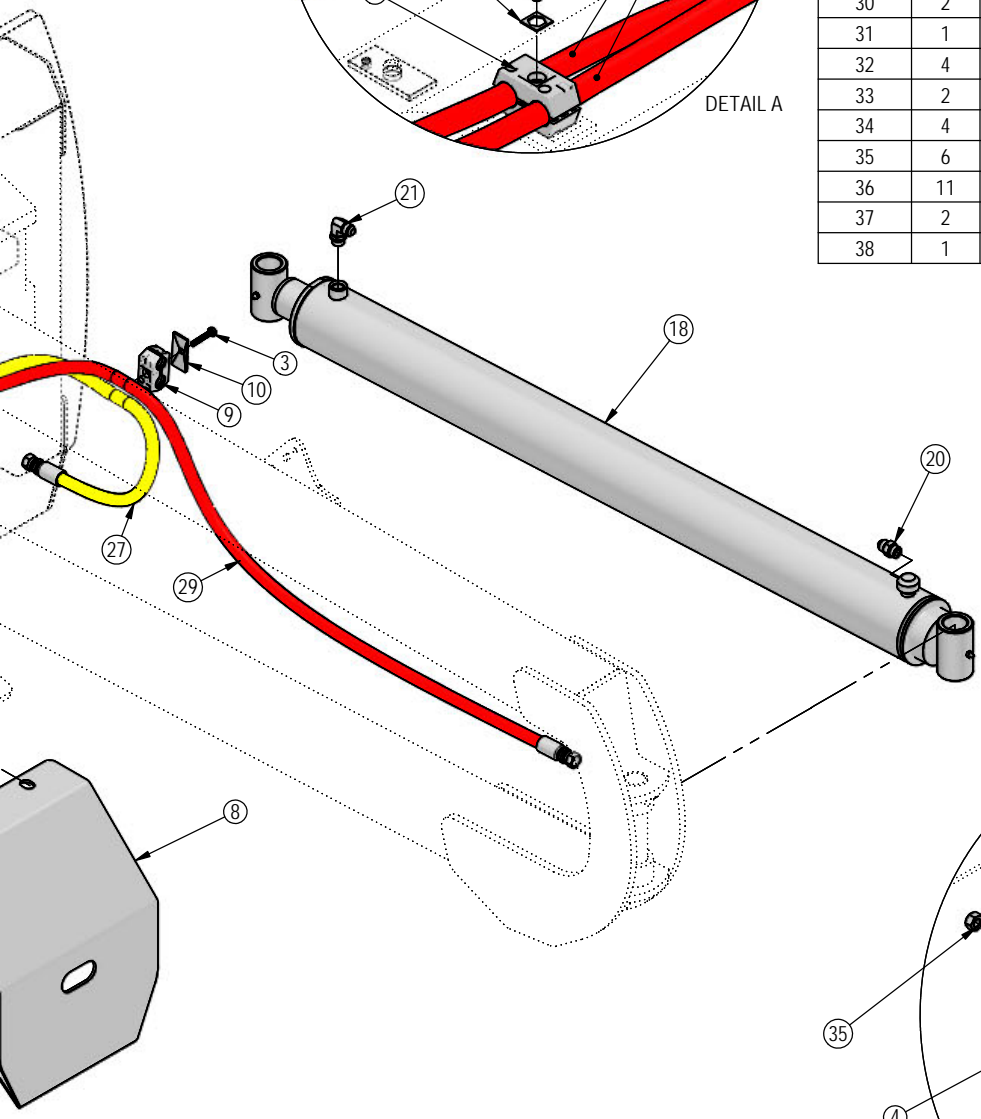
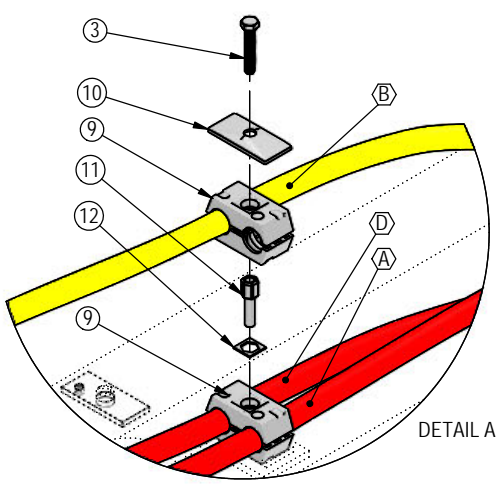

DWG. NO.: 40988

ITEM NO.	QTY.	PART NO.	DESCRIPTION
1	1	14-9366	Ag Pro Non Tilt Bar
2	3	16-20037	5/16" x 2" Hex Bolt Gr 5 NC
3	2	16-20040	5/16" x 2-1/2" Hex Bolt Gr 5 NC
4	2	16-20077	3/8" x 4-1/2" Hex Bolt Gr 5 NC
5	2	16-20564	1" x 3-1/2" Hex Bolt Gr.8 NC
6	2	16-812525	8mm x 1.25mm x 25mm Metric Hex Bolt Gr 10.9
7	1	18-1701	Valve Cover
8	5	18-19311-03-P-087	Hose Clamp
9	5	18-19312-03	Twin Cover Plate
10	1	25-19657	Multi-Coupling Plate - 2 Port Parking Station
11	2	25-19865	Multi-Coupling - Female Coupler
12	1	25-19869	Multi-Coupling Plate - 2 Port - Mobile
13	2	25-40407	Multi-Coupling - Snap Ring
14	2	26-34725	4 x 43.5 Cylinder Tube Ends, Top Port
15	1	31-13332	-6 SAE Breather Fitting
16	9	31-34040	Straight JIC x O-Ring
17	3	31-34050	Straight Thread Elbow 90° JIC x O-Ring
18	1	31-34100	Swivel Nut Elbow 90° JIC

Note: Every hydraulic function from the front to the back of the system is designated by a ○ and a letter and can also be referenced on the Hydraulic Schematic on Page 45.

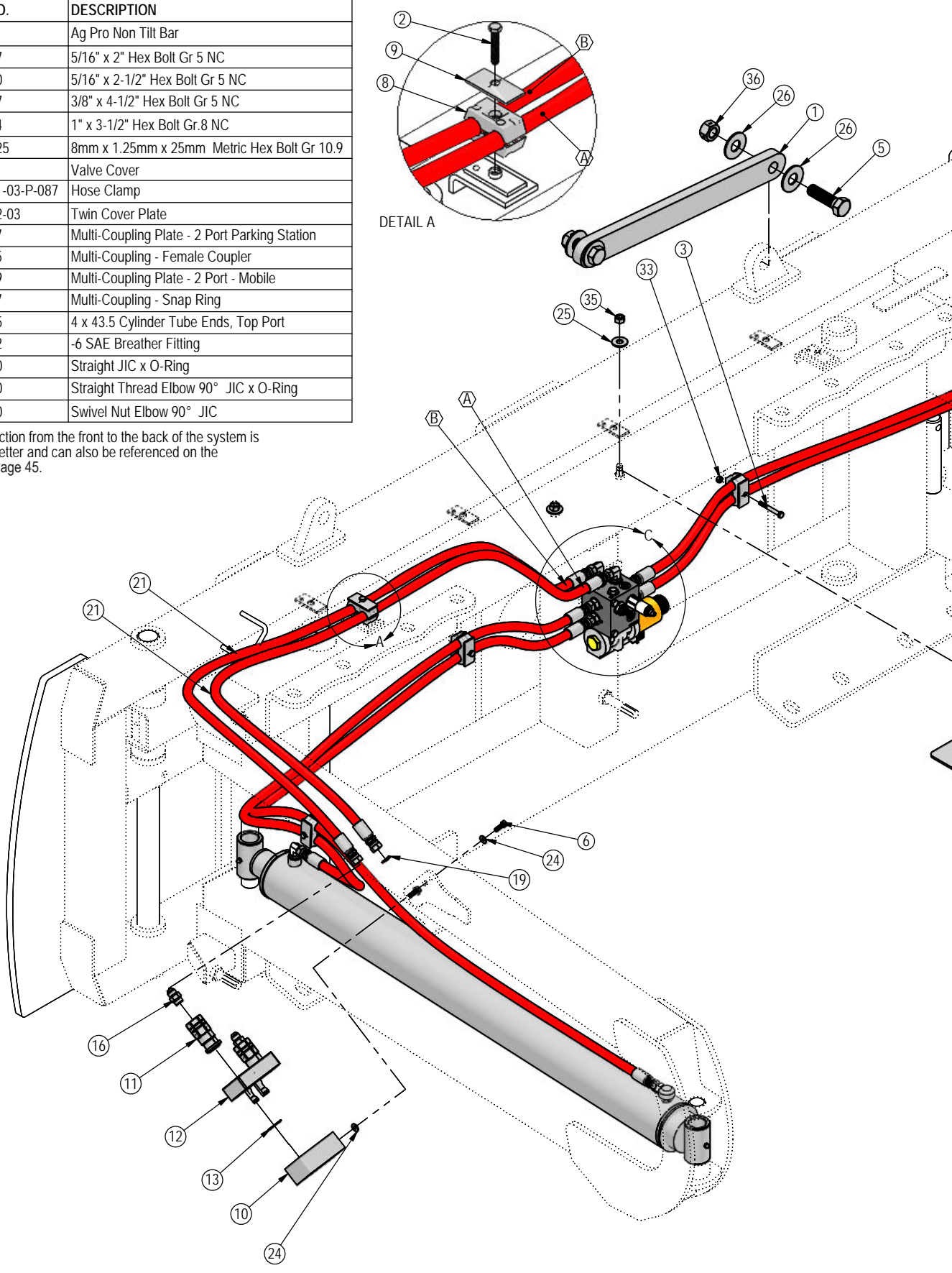

Note: The cylinder part number is stamped on the base end of the cylinder opposite of the hydraulic ports.

No. On Cylinder	Part No.	Description
26-34725	49-12274	Seal Kit 4" (647210) Nitrided Rod - Tube Ends

ITEM NO.	QTY.	PART NO.	DESCRIPTION
19	6	34-18888-RD	-12 Red - Spiral Band
20	2	35-30132	69" x 1/2" -8 JIC/-8 JIC Hose
21	2	35-30133	77" x 1/2" -8JIC/-8JIC Hose
22	2	35-30141	96" x 1/2" -8 JIC/-8 JIC Hose
23	1	56-13305	Hydraulic Valve
24	4	57-20740	1/4" Flat Washer
25	2	57-20744	1/2" Washer
26	4	57-20749	1" Flat Washer
27	1	68-18871	Valve Thermal Relief Cartridge
28	1	68-18873	Valve Solenoid Coil
29	1	68-18874	Valve Coil Nut and O-ring
30	1	68-40443	Valve System Relief Cartridge
31	1	68-40466	Valve Control Center
32	1	68-40469	Valve Block
33	2	70-20581	5/16" Hex Nut Gr 5 NC
34	2	70-20582	3/8" Hex Nut Gr 5 NC
35	2	70-20604	1/2" Hex Center Lock Nut Gr 2 NC
36	2	70-20609	1" Hex Center Lock Nut Gr.2 NC

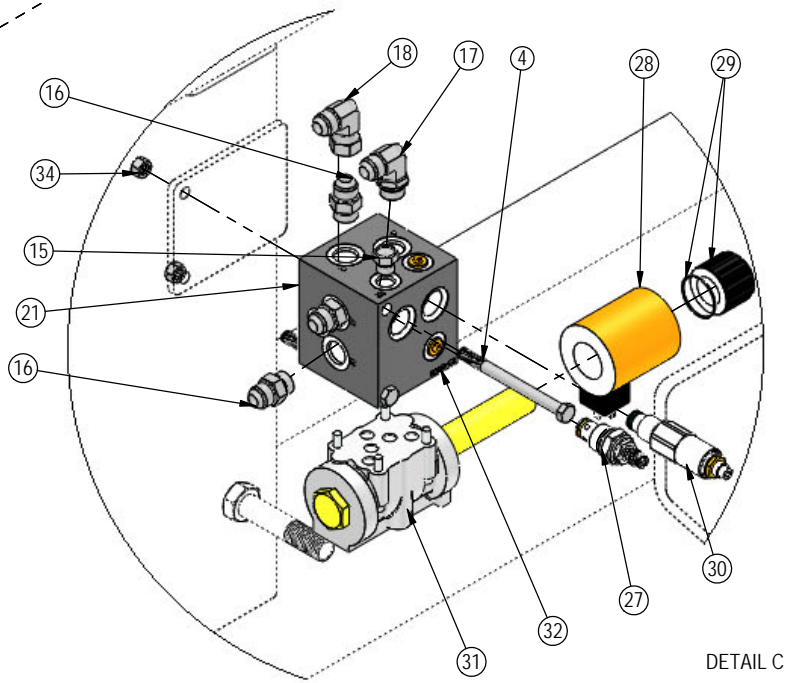
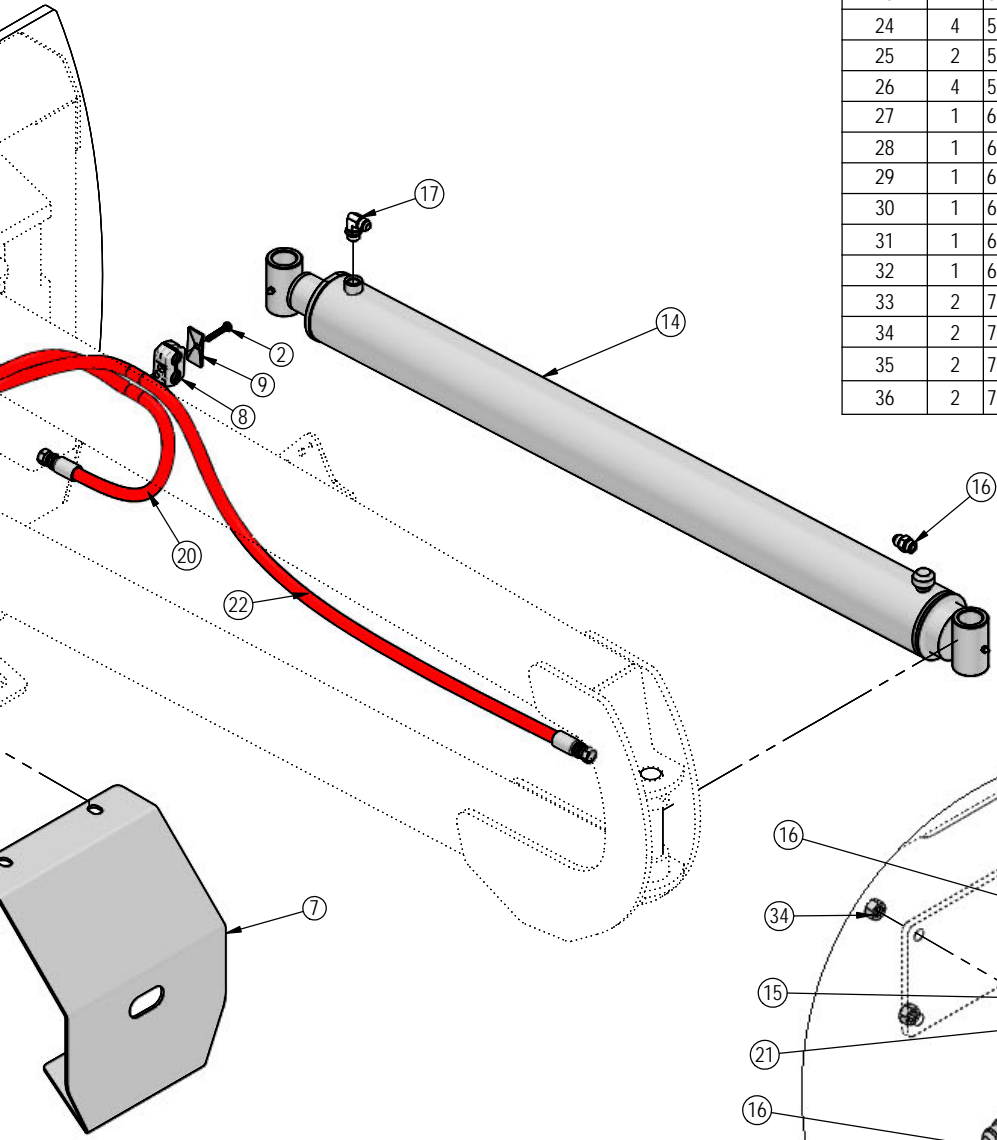

DETAIL C

DETAIL B

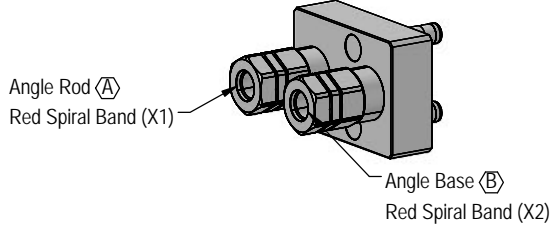

Note: View is from Multi-Coupler Installed on Top Arm.  
 All hoses are marked with colored spiral bands and should be attached to designated ports on the Multi-Coupler.

# No Angle - Hydraulic Tilt System

ITEM NO.	QTY.	PART NO.	DESCRIPTION
1	1	11-40866	Bell Crank
2	1	16-20011	1/4" x 2-3/4" Hex Bolt Gr 5 NC
3	4	16-20128	1/2" x 2" NC Hex Bolt Gr. 5"
4	2	16-20130	1/2" x 2-1/2" Hex Bolt Gr 5 NC
5	6	16-20560	1" x 2-1/2" Hex Bolt Gr 8 NC
6	2	16-20561	1" x 2-3/4" Hex Bolt Gr 8 NC
7	2	16-21065	3/8" x 1-1/4" Carriage Bolt Gr 5 NC
8	4	16-21126	1/2" x 1-1/2" Carriage Bolt Gr 5 NC
9	4	16-35C612	3/8" x 3/4" Flange Bolt
10	2	16-812525	8mm x 1.25mm x 25mm Metric Hex Bolt Gr 10.9
11	1	18-14658	Bracket, Center
12	1	18-40589-L	Multi-Coupler Bracket
13	4	19-13577	NR Pin Spacer Clevis End
14	2	19-40440	.378" ID x .503" OD x .375" Spacer
15	2	19-7774	1" x 1" Spring Bushing
16	1	25-19657	Multi-Coupling Plate - 2 Port Parking Station
17	2	25-19865	Multi-Coupling - Female Coupler
18	1	25-19869	Multi-Coupling Plate - 2 Port - Mobile
19	2	25-40407	Multi-Coupling - Snap Ring
20	2	26-34711	4 x 8 Hydraulic Cylinder
21	2	27-2409	Pinch Decal (Hand)
22	2	27-9503	Pinch Decal (Foot)
23	2	31-34040	Straight JIC x O-Ring
24	2	31-34050	Straight Thread Elbow 90° JIC x O-Ring
25	2	31-34060	Branch Tee JIC x O-Ring
26	1	32-16980 R3	Tilt Frame Weld
27	1	34-17799	Latch Spring
28	6	34-18888-GR	-12 Green - Spiral Band
29	2	35-30022	39" x 3/8" -8JIC/-8JIC Hose
30	1	35-31184	37" x 1/2" -8 JIC/-8 JIC Hose W/ Cordura
31	1	35-31185	47" x 1/2" -8 JIC/-8 JIC Hose W/ Cordura
32	1	39-14663	Latch
33	1	39-14665	Handle Weld
34	1	39-3072	Rubber Handle
35	4	43-13580	Pin Weld
36	2	43-18486	Ag Pro SS QA Lock Pin
37	1	44-41874	Plate, Link
38	4	44-8490	Spacer
39	1	45-40870-L	SS Bolt in Quick Attach - Left
40	1	45-40870-R	SS Bolt in Quick Attach - Right
41	2	57-20740	5/16" Flat Washer
42	2	57-20742	3/8" Flat Washer
43	12	57-20744	1/2" Flat Washer
44	16	57-20819	1" Flat Washer Heavy Duty Gr 8
45	4	57-40408	3/8" Flat Nylon Washer
46	10	70-20604	1/2" Center Lock Hex Nut
47	2	70-20607	3/4" Center Lock Hex Nut Gr 2 NC
48	1	70-20610	1/4" Nyloc Hex Nut Gr 5 NC
49	2	70-20612	3/8" Nyloc Hex Nut Gr 5 NC
50	8	70-20999	1" Hex Top Lock Nut Gr 8 NC
51	2	75-40869	Link, Bell Crank To Pin

**Note:** Every hydraulic function from the front to the back of the system is designated by a  $\circ$  and a letter and can also be referenced on the Hydraulic Schematic on Page 45.

**Note:** The cylinder part number is stamped on the base end of the cylinder opposite of the hydraulic ports.

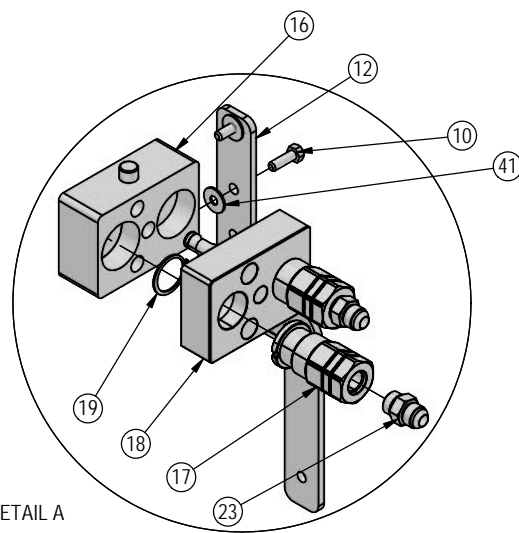

DETAIL A

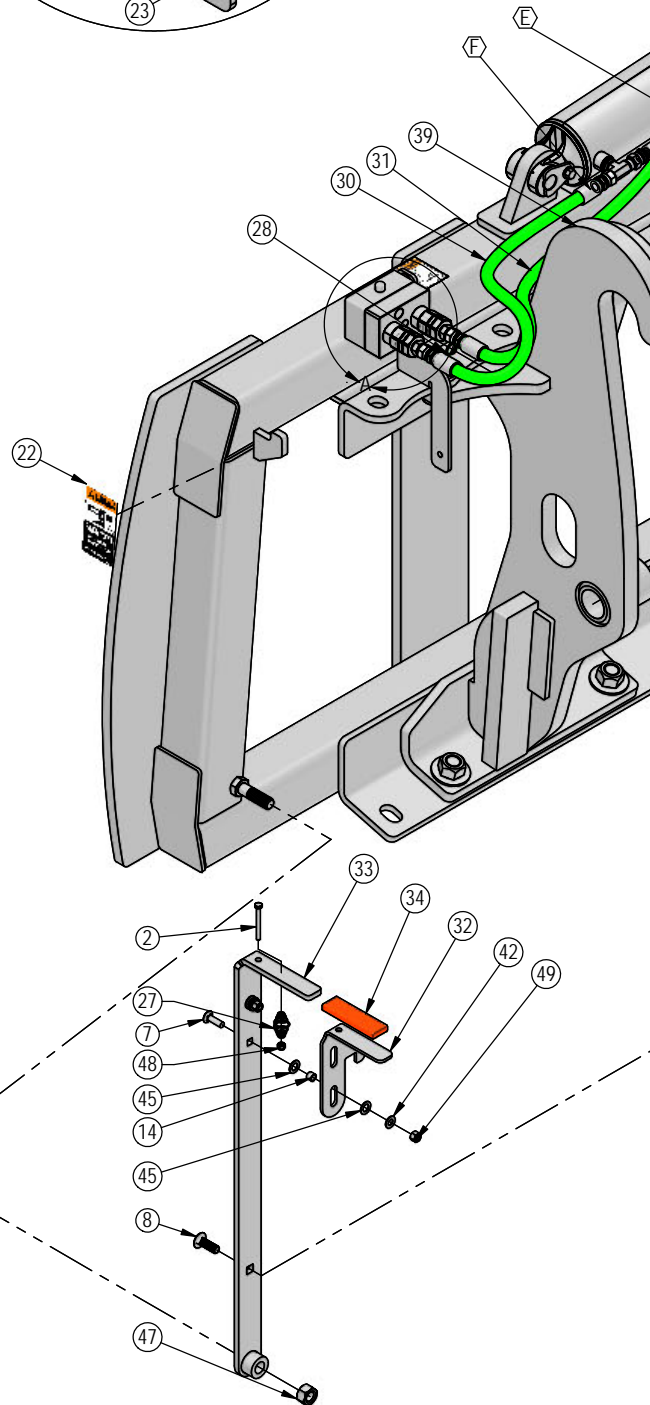

No. On Cylinder	Part No.	Description
26-34711	49-12271	Seal Kit 4" (647135) Nitrided Rod - Clevis Ends

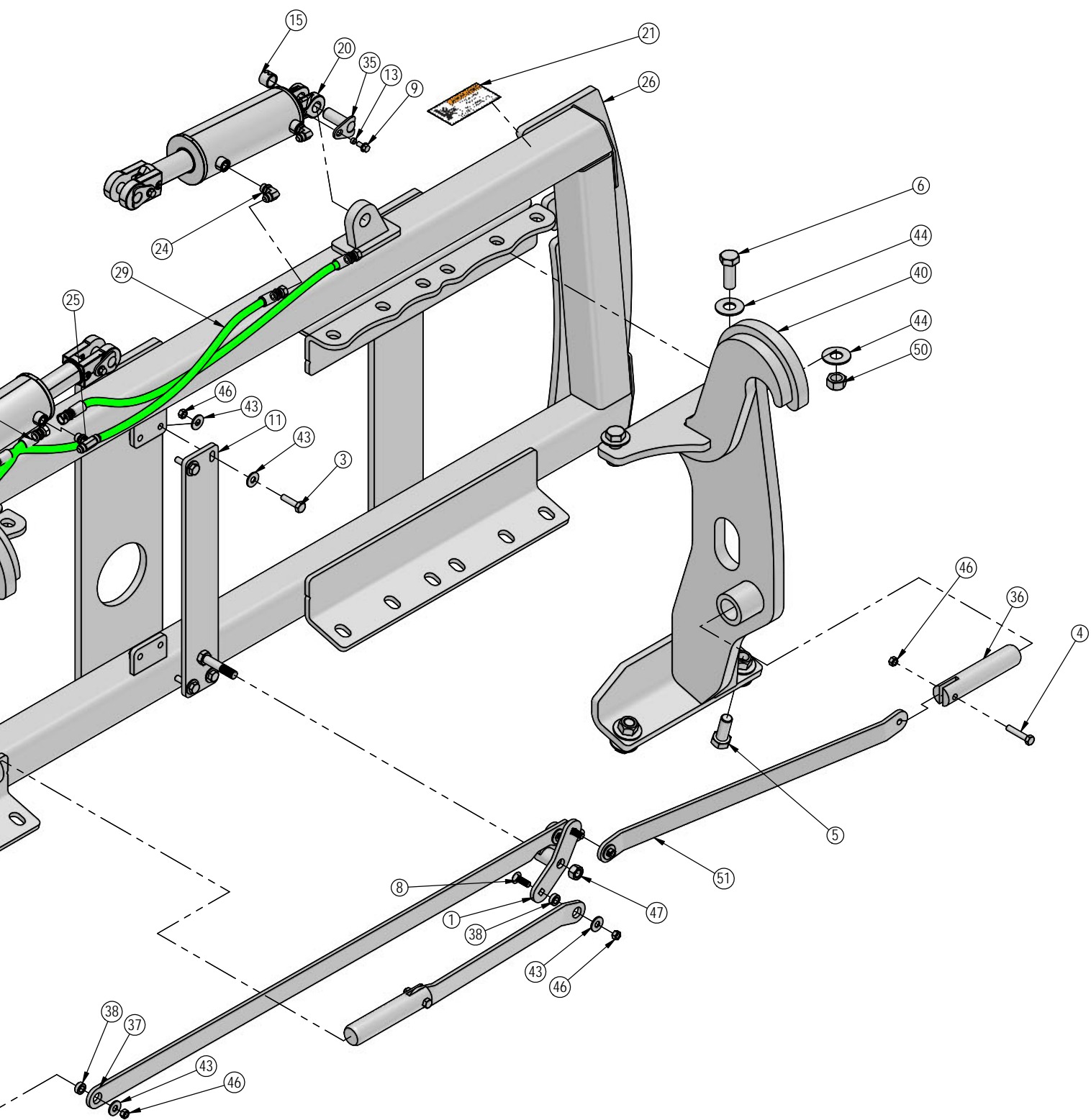

DETAIL B

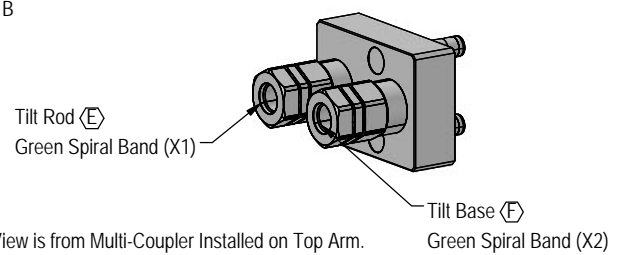

Note: View is from Multi-Coupler Installed on Top Arm.  
 All hoses are marked with colored spiral bands and should be attached to designated ports on the Multi-Coupler.

DWG. NO.: 40984

ITEM NO.	QTY.	PART NO.	DESCRIPTION
1	2	16-20035	5/16" x 1-1/4" Hex Bolt Gr. 5
2	4	16-20036	5/16" x 1-1/2" Hex Bolt Gr 5 NC
3	2	16-20126	1/2" x 1-1/2" Hex Bolt Gr 5 NC
4	2	16-812525	8mm x 1.25mm x 25mm Metric Hex Bolt Gr 10.9
5	4	18-15684	12-20 Hose Hold Down Plate
6	2	18-19311-02-P-062	Hose Clamp
7	2	18-19312-02	Twin Cover Plate
8	1	25-18956	Multi-Coupling Plate - 4 Port Parking Station
9	4	25-19865	Multi-Coupling - Female Coupler
10	1	25-19866	Multi-Coupling Plate - 4 Port Mobile
11	4	25-40407	Multi-Coupling - Snap Ring
12	2	26-34741	3 x 48 Hydraulic Cylinder
13	4	31-34040	Straight JIC x O-Ring
14	4	31-34050	Straight Thread Elbow 90° JIC x O-Ring
15	2	34-17585	Cylinder Strap
16	3	34-18888-BL	-12 Blue - Spiral Band
17	3	34-18888-BR	-12 Brown - Spiral Band
18	1	35-11686-1820	182" x 3/8" -8JIC/-8JIC Hose
19	1	35-11686-1980	198" x 3/8" -8JIC/-8JIC Hose
20	1	35-11686-2270	227" x 3/8" -8JIC/-8JIC Hose
21	1	35-11686-2560	256" x 3/8" -8JIC/-8JIC Hose
22	4	43-16306	Cylinder Pin w/ Cotter Pins
23	4	43-18943	3/16" x 1-1/2" Cotter Pin
24	4	43-7767	Cylinder Pin Clip
25	2	57-20740	1/4" Flat Washer
26	4	57-20744	1/2" Flat Washer
27	2	70-20604	1/2" Center Lock Hex Nut

Note: Every hydraulic function from the front to the back of the system is designated by a letter and can also be referenced on the Hydraulic Schematic on Page 46.

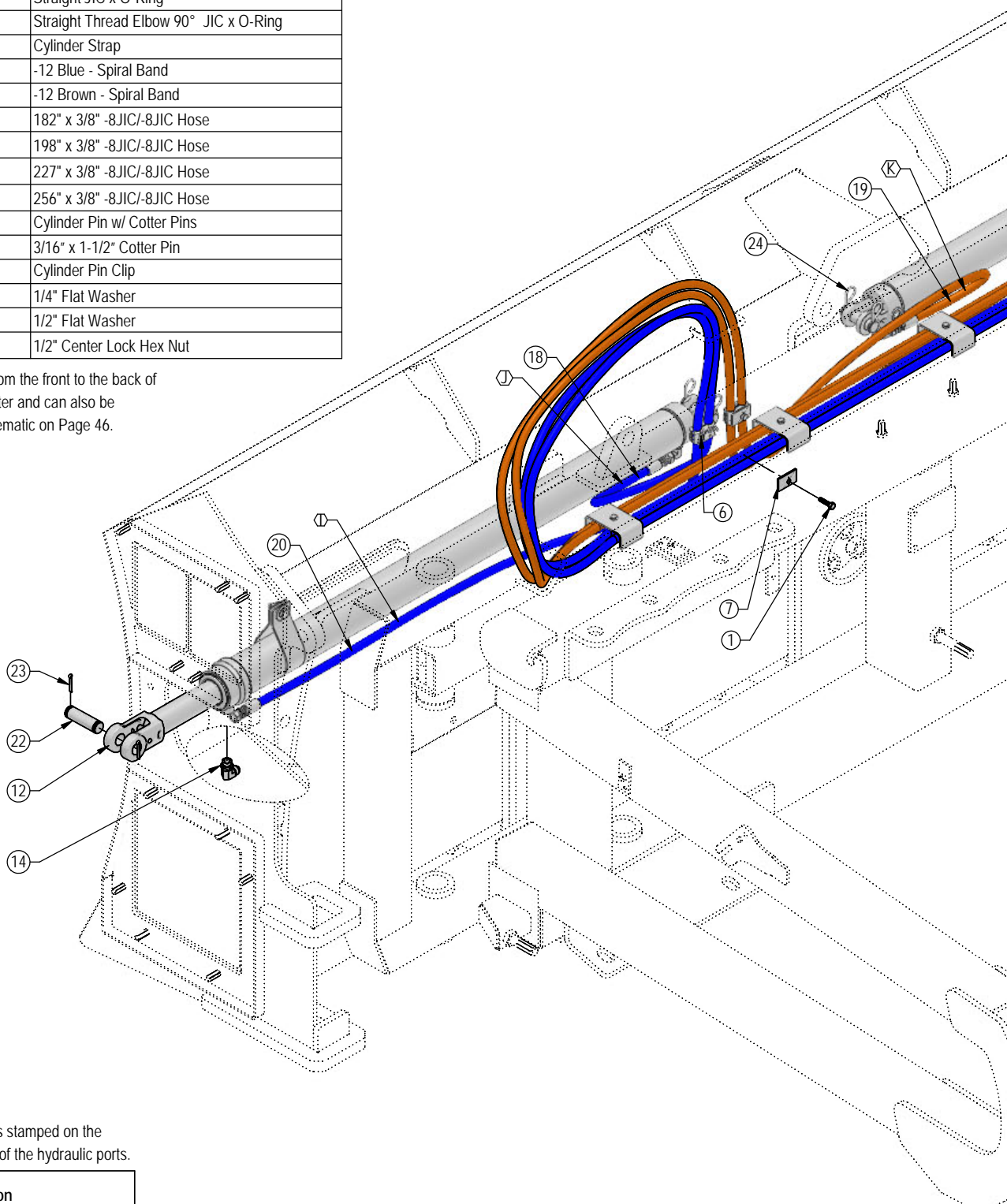

Note: The cylinder part number is stamped on the base end of the cylinder opposite of the hydraulic ports.

No. On Cylinder	Part No.	Description
26-34741	49-17797	Seal Kit 3" (649210)

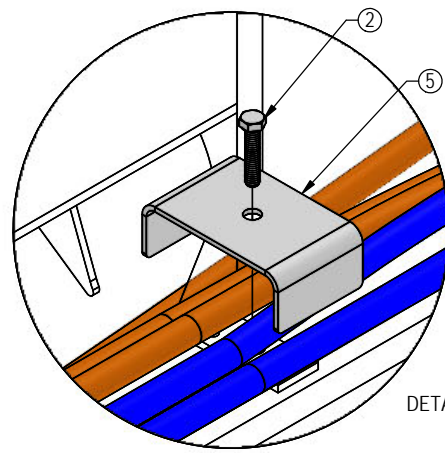
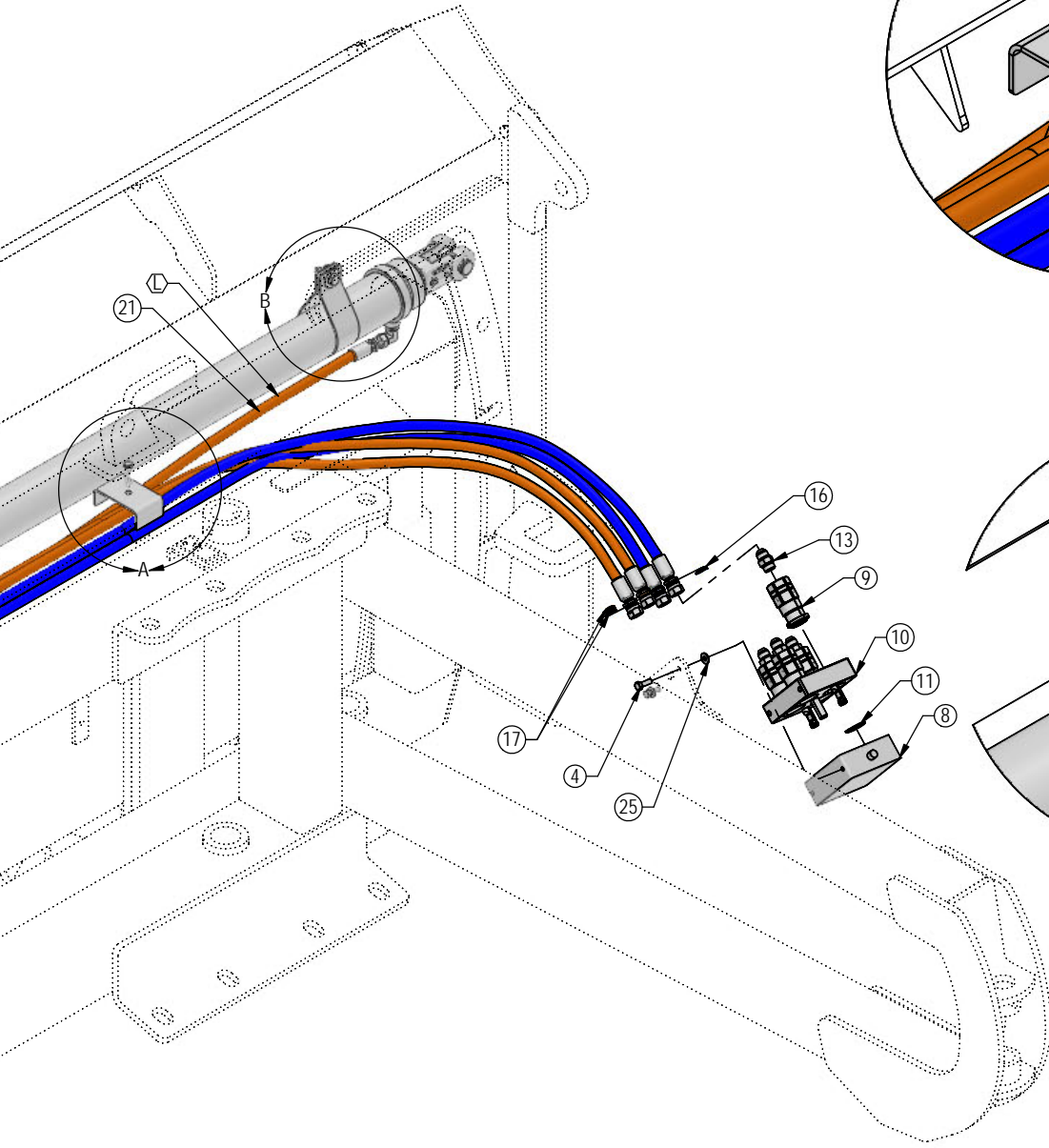

DETAIL A

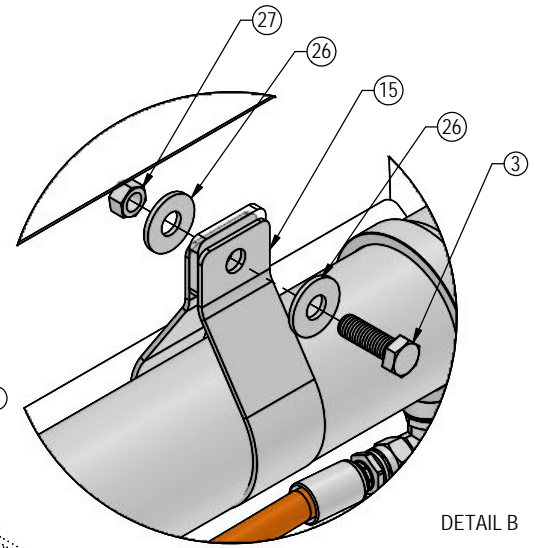

DETAIL B

DETAIL C

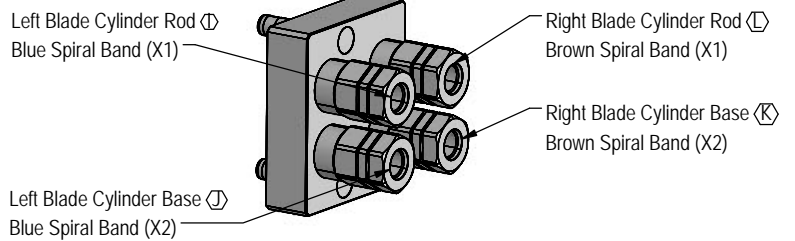

**Note:** View is from Multi-Coupler Installed on Top Arm.  
All hoses are marked with colored spiral bands and should be attached to designated ports on the Multi-Coupler.

DWG. NO.: 40428

ITEM NO.	QTY.	PART NO.	DESCRIPTION
1	1	16-20043	5/16" x 3-1/4" Hex Bolt Gr. 5 NC
2	2	16-20126	1/2" x 1-1/2" Hex Bolt Gr 5 NC
3	2	16-812525	8mm x 1.25mm x 25mm Metric Hex Bolt Gr 10.9
4	2	18-19311-02-P-062	Hose Clamp
5	2	18-19312-02	Twin Cover Plate
6	1	18-40589-R	Multi-Coupler Bracket
7	1	25-18956	Multi-Coupling Plate - 4 Port Parking Station
8	4	25-19865	Multi-Coupling - Female Coupler
9	1	25-19866	Multi-Coupling Plate - 4 Port Mobile
10	4	25-40407	Multi-Coupling - Snap Ring
11	2	26-34741	3 x 48 Hydraulic Cylinder
12	4	31-34040	Straight JIC x O-Ring
13	4	31-34050	Straight Thread Elbow 90° JIC x O-Ring
14	2	34-17585	Cylinder Strap
15	3	34-18888-BL	-12 Blue - Spiral Band
16	3	34-18888-BR	-12 Brown - Spiral Band
17	1	35-11686-0670	67" x 3/8" -8JIC/-8JIC Hose
18	1	35-11686-0820	82" x 3/8" -8JIC/-8JIC Hose
19	1	35-11686-1000	100" x 3/8" -8JIC/-8JIC Hose
20	1	35-11686-1510	151" x 3/8" -8JIC/-8JIC Hose
21	4	43-16306	Cylinder Pin w/ Cotter Pins
22	4	43-18943	3/16" x 1-1/2" Cotter Pin
23	4	43-7767	Cylinder Pin Clip
24	2	57-20740	1/4" Flat Washer
25	4	57-20744	1/2" Flat Washer
26	2	70-20604	1/2" Center Lock Hex Nut
27	1	70-20611	5/16" Nyloc Hex Nut Gr. 5

Note: Every hydraulic function from the front to the back of the system is designated by a letter and can also be referenced on the Hydraulic Schematic on Page 46.

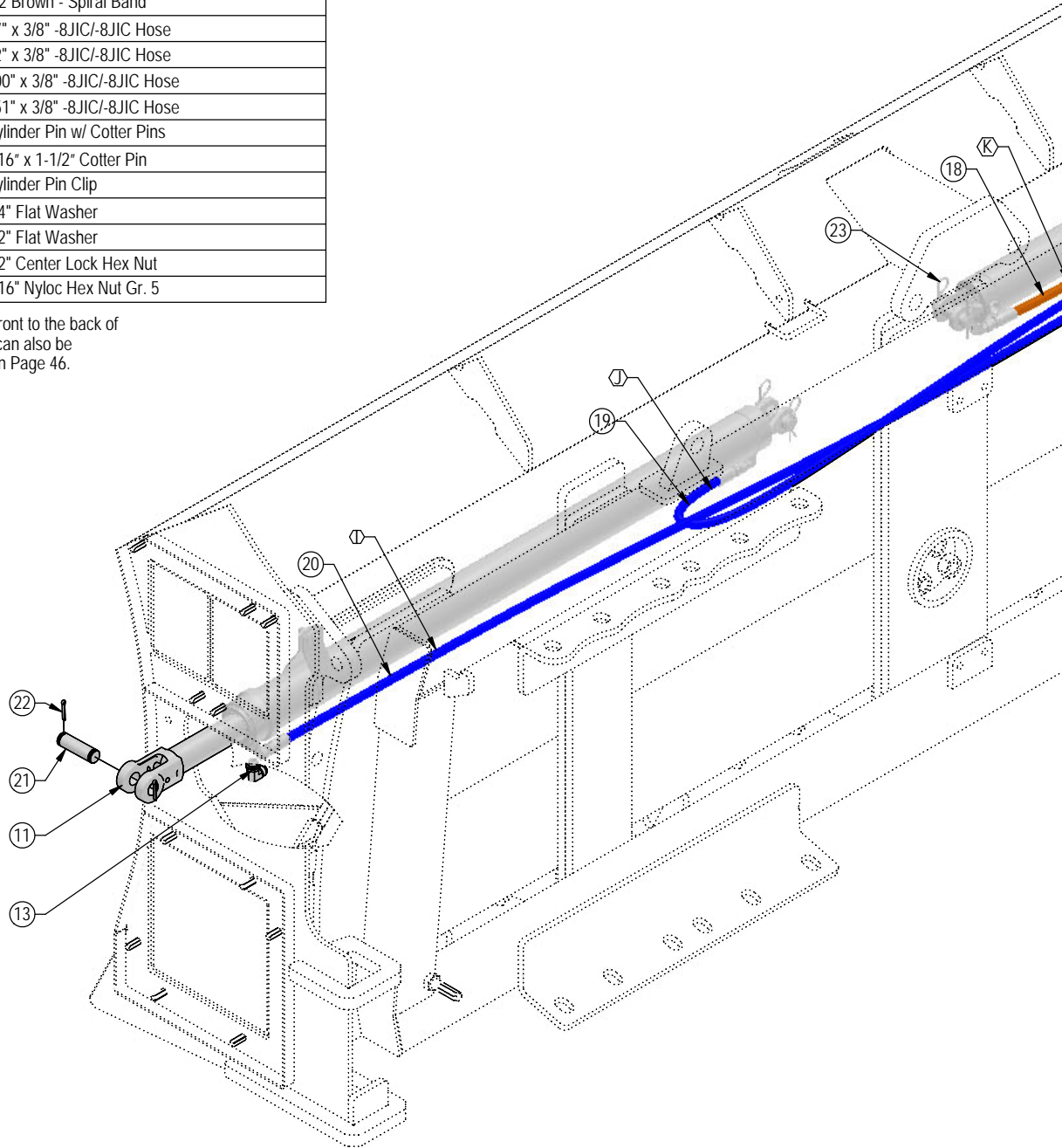

Note: The cylinder part number is stamped on the base end of the cylinder opposite of the hydraulic ports.

No. On Cylinder	Part No.	Description
26-34741	49-17797	Seal Kit 3" (649210)



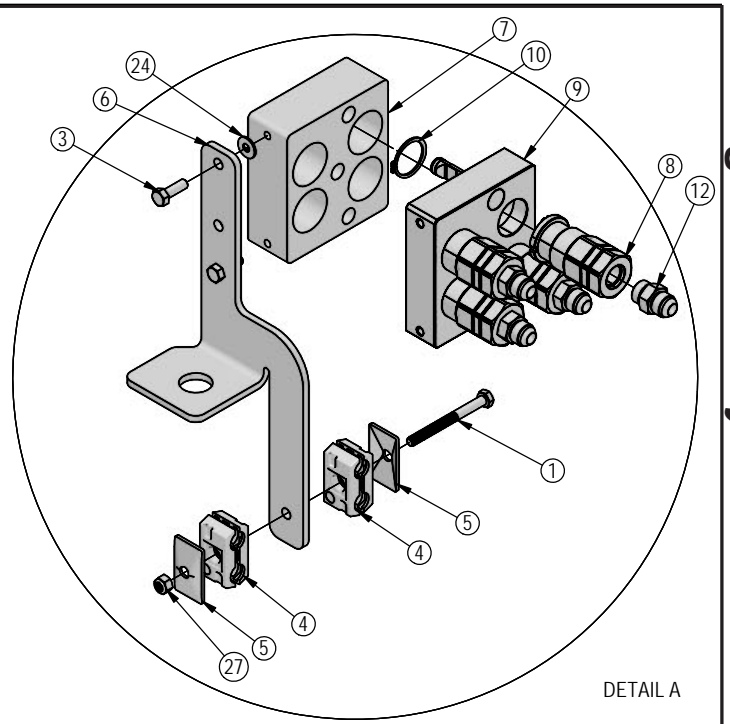
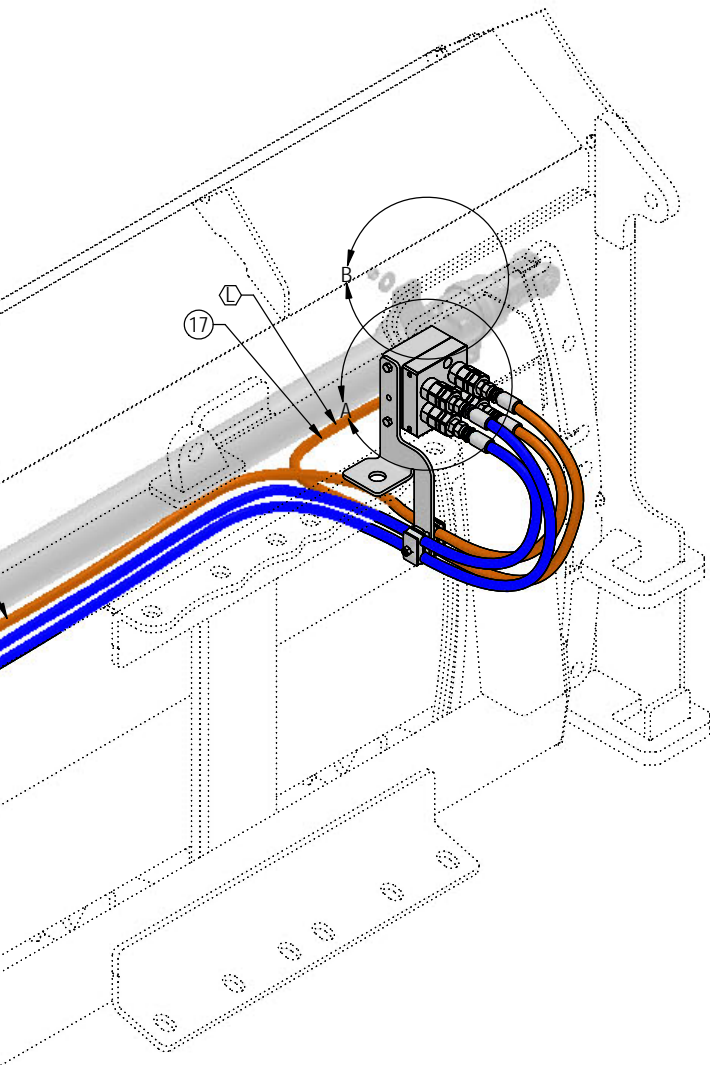

DETAIL A

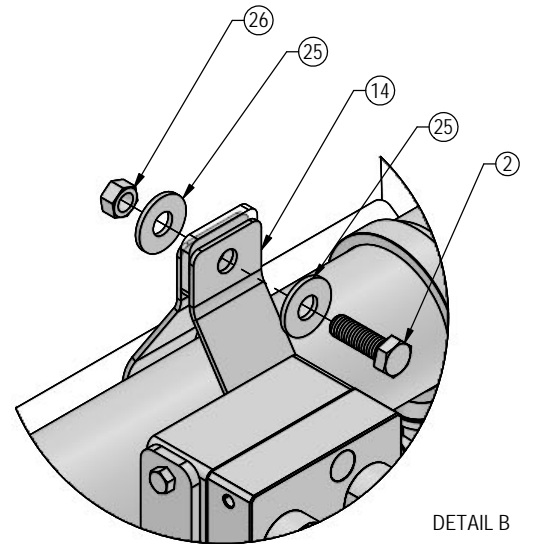

DETAIL B

DETAIL C

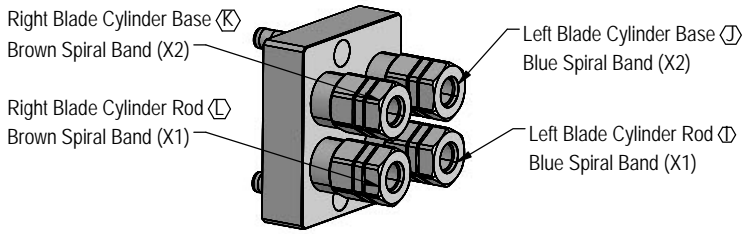

**Note:** View is from Multi-Coupler Installed on Top Arm.  
 All hoses are marked with colored spiral bands and should be attached to designated ports on the Multi-Coupler.

DWG. NO.: 40488

ITEM NO.	QTY.	PART NO.	DESCRIPTION
1	1	15-17590	12-20 NANT Blade Weld
2	7	16-20560	1" x 2-1/2" Hex Bolt Gr 8 NC
3	1	16-20561	1" x 2-3/4" Hex Bolt Gr.8 NC
4	1	45-40870-L	SS Bolt in Quick Attach - Left
5	1	45-40870-R	SS Bolt in Quick Attach - Right
6	16	57-20819	1" Flat Washer Heavy Duty Gr 8 (USS)
7	8	70-20999	1" Hex Top Lock Nut Gr 8 NC (YZ)

See Pages 16-17 for Blade Components

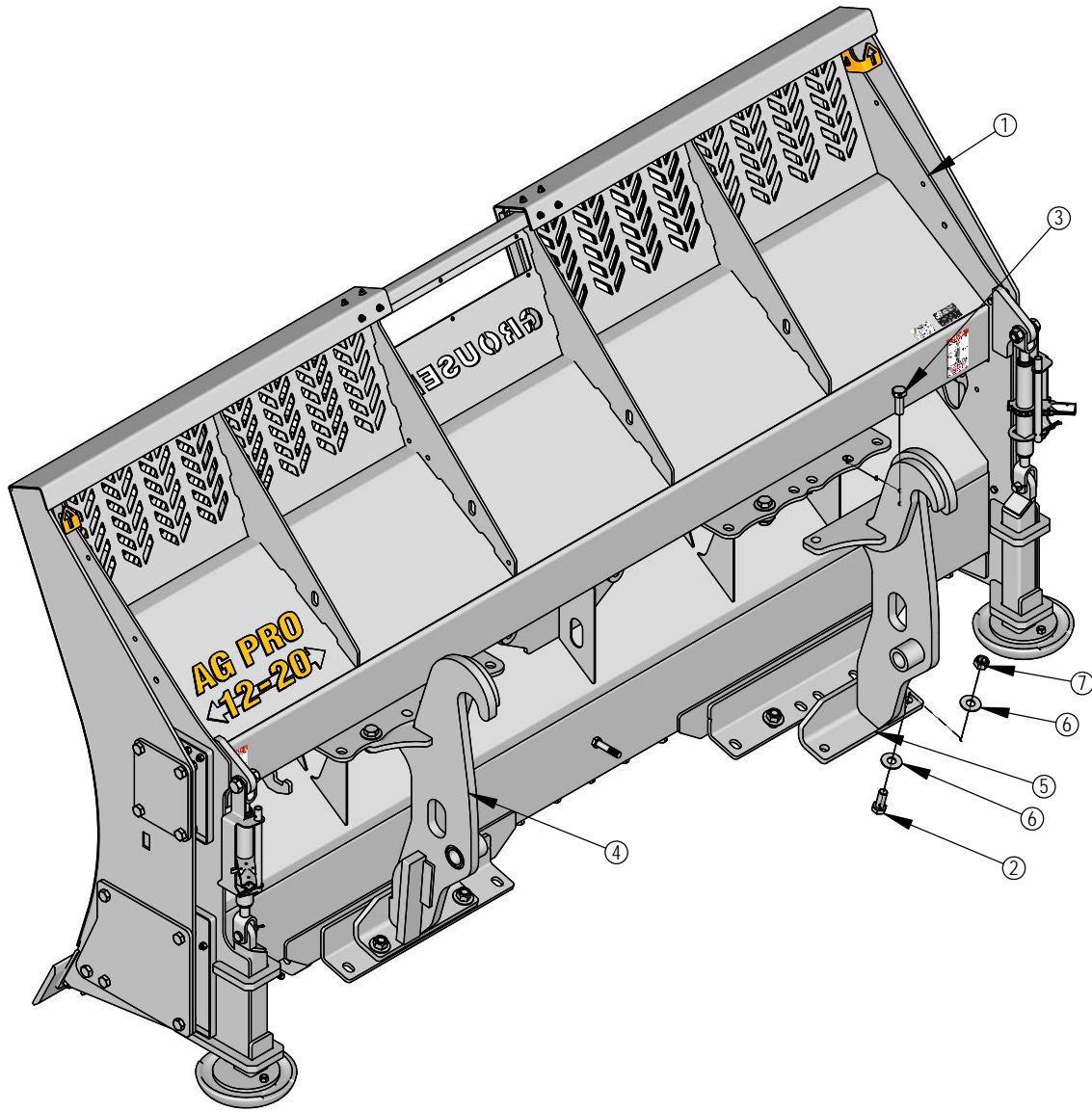

ITEM NO.	QTY.	PART NO.	DESCRIPTION
1	1	11-40866	Bell Crank
2	1	16-20011	1/4" x 2-3/4" Hex Bolt Gr 5 NC
3	2	16-20130	1/2" x 2-1/2" Hex Bolt Gr 5 NC
4	2	16-21065	3/8" x 1-1/4" Carriage Bolt Gr 5 NC
5	4	16-21126	1/2" x 1-1/2" Carriage Bolt Gr 5 NC
6	2	19-40440	.378" ID x .503" OD x .375" Spacer
7	1	34-17799	Latch Spring
8	1	39-14663	Latch
9	1	39-14665	Handle Weld
10	1	39-3072	Rubber Handle
11	2	43-18486	AG Pro SS QA Lock Pin
12	1	44-41874	Plate, Link
13	4	44-8490	Spacer
14	2	57-20742	3/8" Flat Washer
15	4	57-20744	1/2" Washer
16	4	57-40408	3/8" Flat Nylon Washer
17	6	70-20604	1/2" Hex Center Lock Nut Gr 2 NC
18	2	70-20607	3/4" Center Lock Hex Nut Gr 2 NC
19	1	70-20610	1/4" Nyloc Hex Nut Gr 5 NC
20	2	70-20612	3/8" Nyloc Hex Nut Gr 5 NC
21	2	75-40869	Link, Bell Crank To Pin

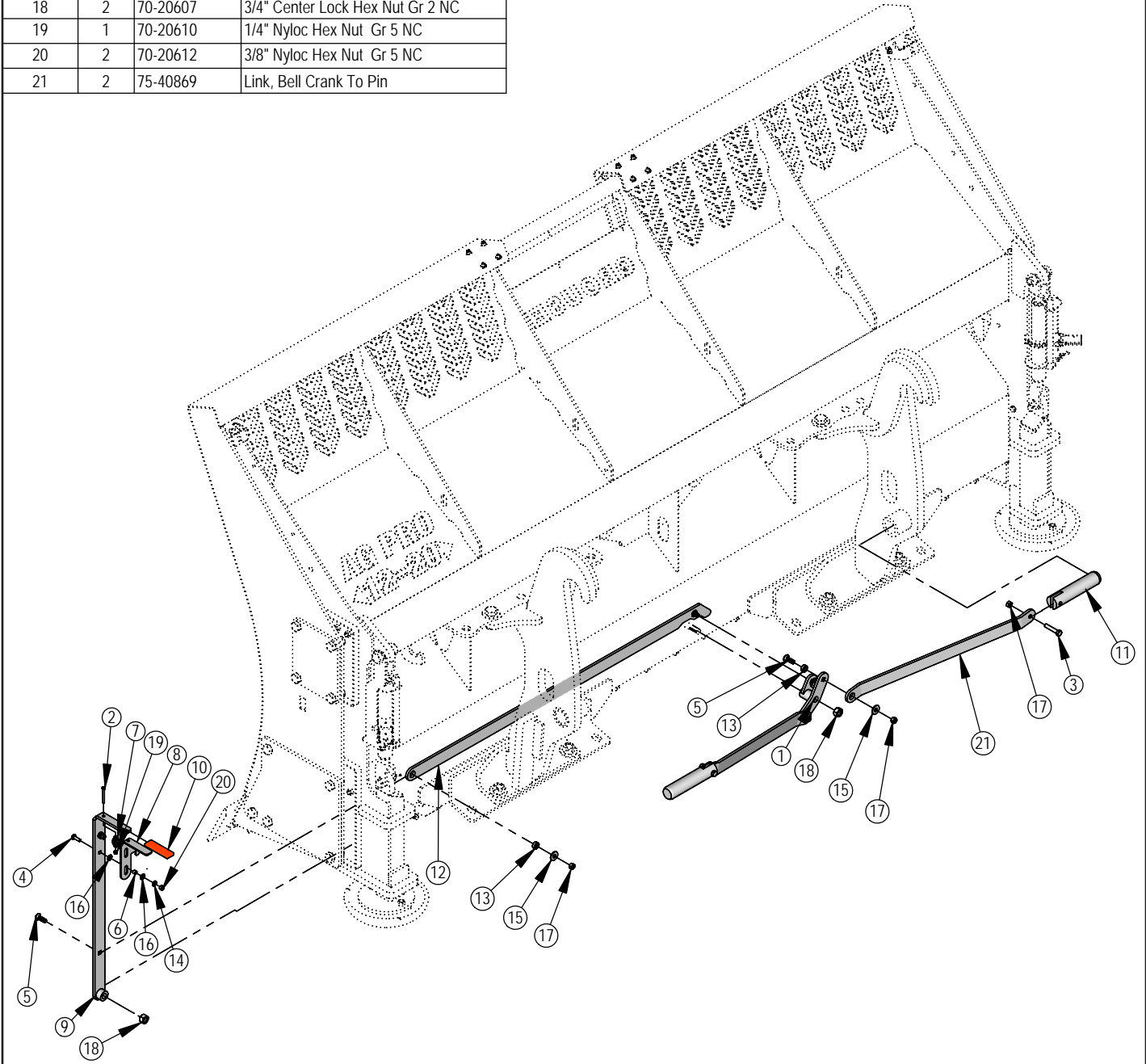

ITEM NO.	QTY.	PART NO.	DESCRIPTION
1	1	16-20043	5/16" x 3-1/4" Hex Bolt Gr. 5 NC
2	2	16-20126	1/2" x 1-1/2" Hex Bolt Gr 5 NC
3	2	16-812525	8mm x 1.25mm x 25mm Metric Hex Bolt Gr 10.9
4	2	18-19311-02-P-062	Hose Clamp
5	2	18-19312-02	Twin Cover Plate
6	1	18-40589-R	Multi-Coupler Bracket
7	1	25-18956	Multi-Coupling Plate - 4 Port Parking Station
8	4	25-19865	Multi-Coupling - Female Coupler
9	1	25-19866	Multi-Coupling Plate - 4 Port Mobile
10	4	25-40407	Multi-Coupling - Snap Ring
11	2	26-34741	3 x 48 Hydraulic Cylinder
12	4	31-34040	Straight JIC x O-Ring
13	4	31-34050	Straight Thread Elbow 90° JIC x O-Ring
14	2	34-17585	Cylinder Strap
15	3	34-18888-BL	-12 Blue - Spiral Band
16	3	34-18888-BR	-12 Brown - Spiral Band
17	2	35-11686-0690	69" x 3/8" -8JIC/-8JIC Hose
18	1	35-11686-0930	93" x 3/8" -8JIC/-8JIC Hose
19	1	35-11686-1440	144" x 3/8" -8JIC/-8JIC Hose
20	4	43-16306	Cylinder Pin w/ Cotter Pins
21	4	43-18943	3/16" x 1-1/2" Cotter Pin
22	4	43-7767	Cylinder Pin Clip
23	2	57-20740	1/4" Flat Washer
24	4	57-20744	1/2" Flat Washer
25	2	70-20604	1/2" Center Lock Hex Nut
26	1	70-20611	5/16" Nyloc Hex Nut Gr. 5

Note: Every hydraulic function from the front to the back of the system is designated by a letter and can also be referenced on the Hydraulic Schematic on Page 46.

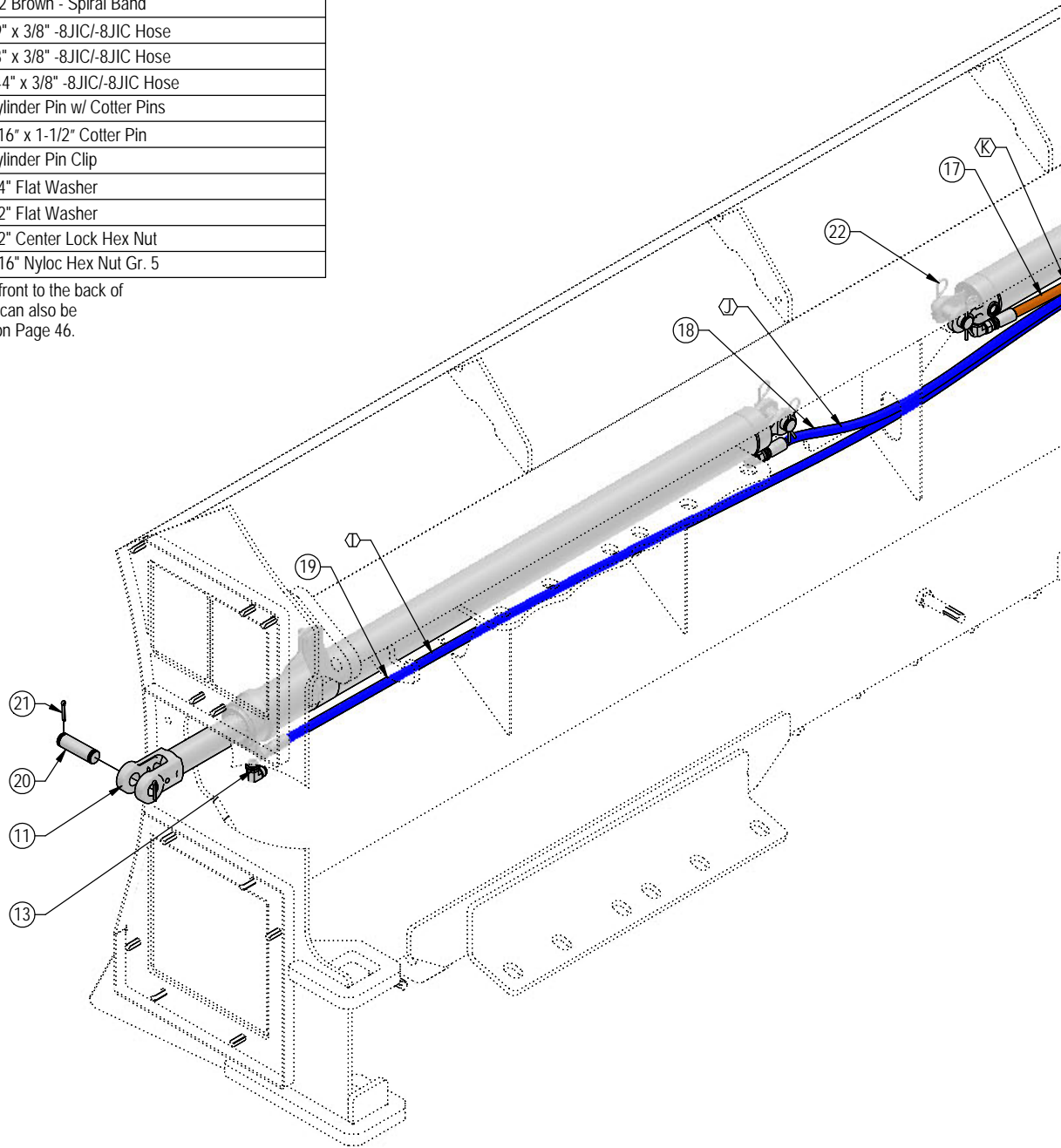

Note: The cylinder part number is stamped on the base end of the cylinder opposite of the hydraulic ports.

No. On Cylinder	Part No.	Description
26-34741	49-17797	Seal Kit 3" (649210)

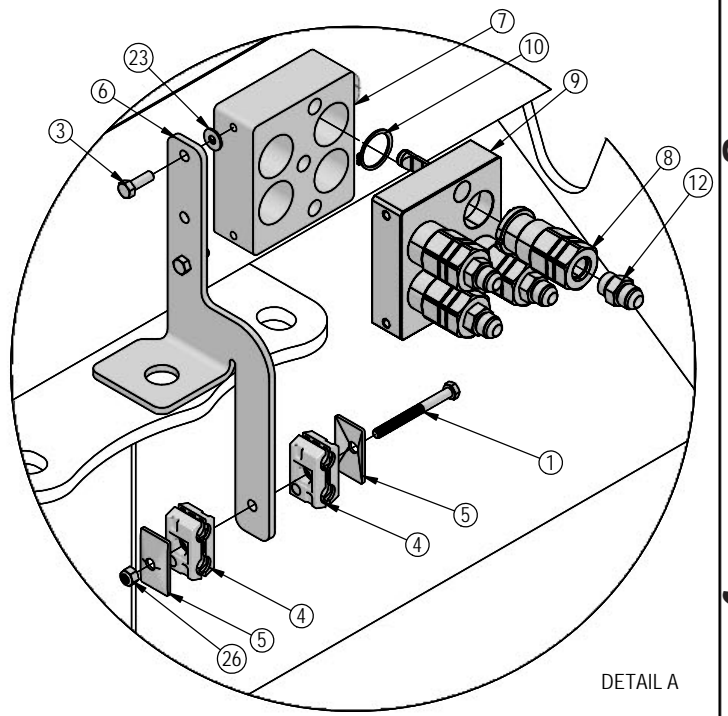
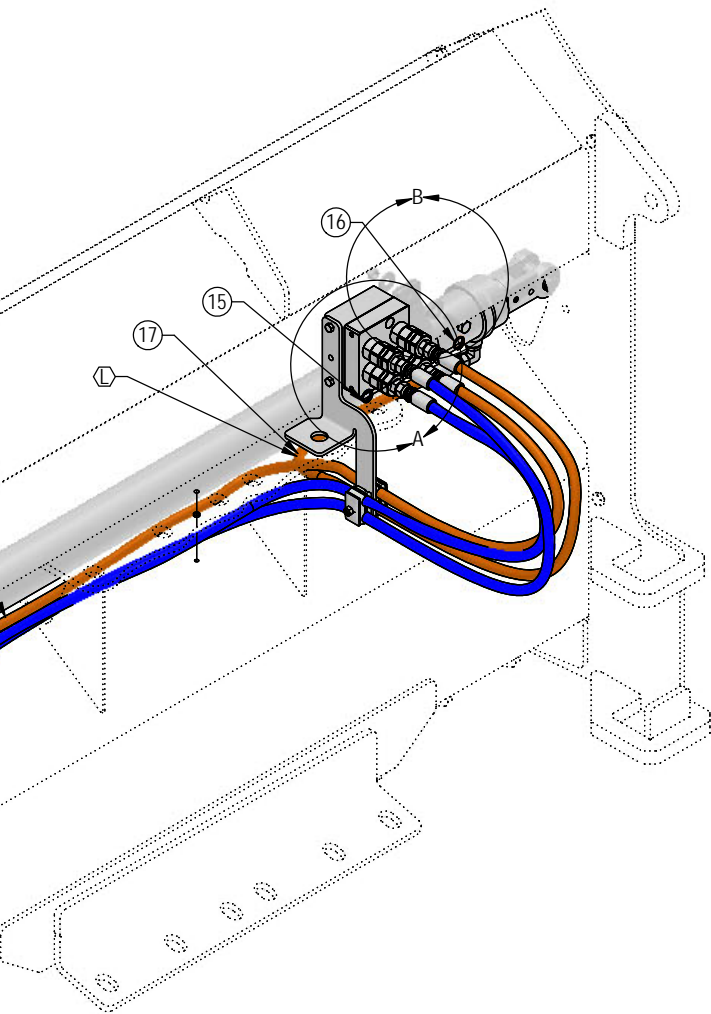

DETAIL A

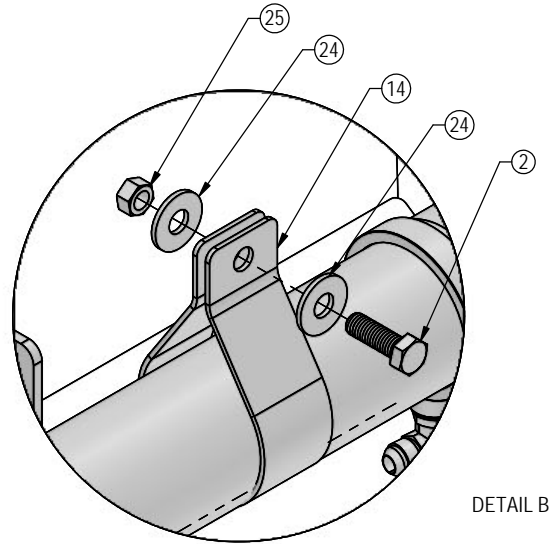

DETAIL B

DETAIL C

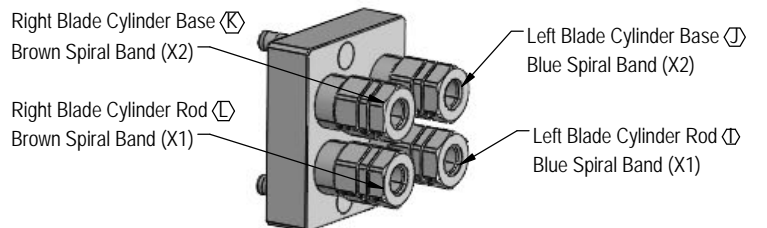

**Note:** View is from Multi-Coupler Installed on Top Arm.  
All hoses are marked with colored spiral bands and should be attached to designated ports on the Multi-Coupler.

DWG. NO.: 40421

ITEM NO.	PART NO.	VALVE QTY.	TEE'D QTY.	DESCRIPTION
1	16-20035	1	1	5/16" x 1-1/4" Hex Bolt Gr. 5
2	16-20036	4	4	5/16" x 1-1/2" Hex Bolt Gr 5 NC
3	16-20126	2	2	1/2" x 1-1/2" Hex Bolt Gr 5 NC
4	16-35C612	2	-	3/8" x 3/4" Flange Bolt
5	16-812525	2	2	8mm x 1.25mm x 25mm Metric Hex Bolt Gr 10.9
6	18-15684	4	4	12-20 Hose Hold Down Plate
7	18-19311-02-P-062	1	1	Hose Clamp
8	18-19312-02	1	1	Twin Cover Plate
9	25-19657	1	1	Multi-Coupling Plate - 2 Port Parking Station
10	25-19865	2	2	Multi-Coupling - Female Coupler
11	25-19869	1	1	Multi-Coupling Plate - 2 Port - Mobile
12	25-40407	2	2	Multi-Coupling - Snap Ring
13	26-34741	2	2	3 x 48 Hydraulic Cylinder
14	31-34030	-	2	Bulkhead Run Tee JIC
15	31-34040	4	2	Straight JIC x O-Ring

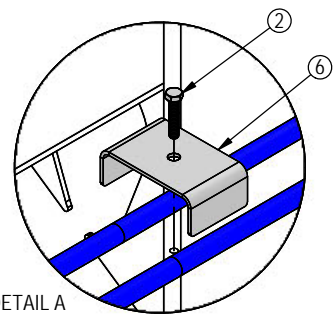

Note: Every hydraulic function from the front to the back of the system is designated by a letter and can also be referenced on the Hydraulic Schematic on Page 46.

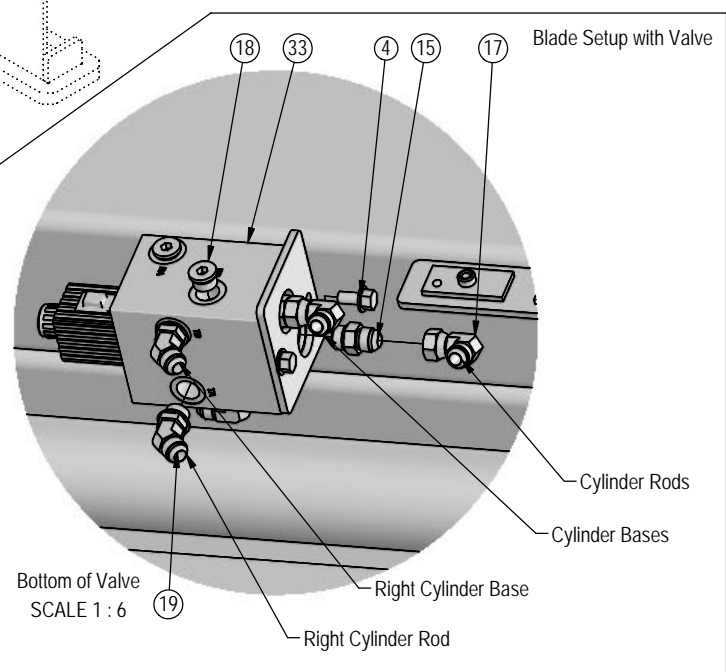
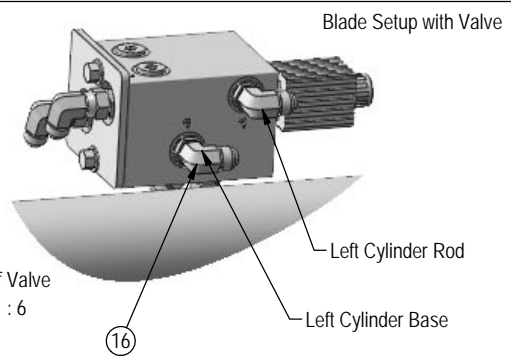
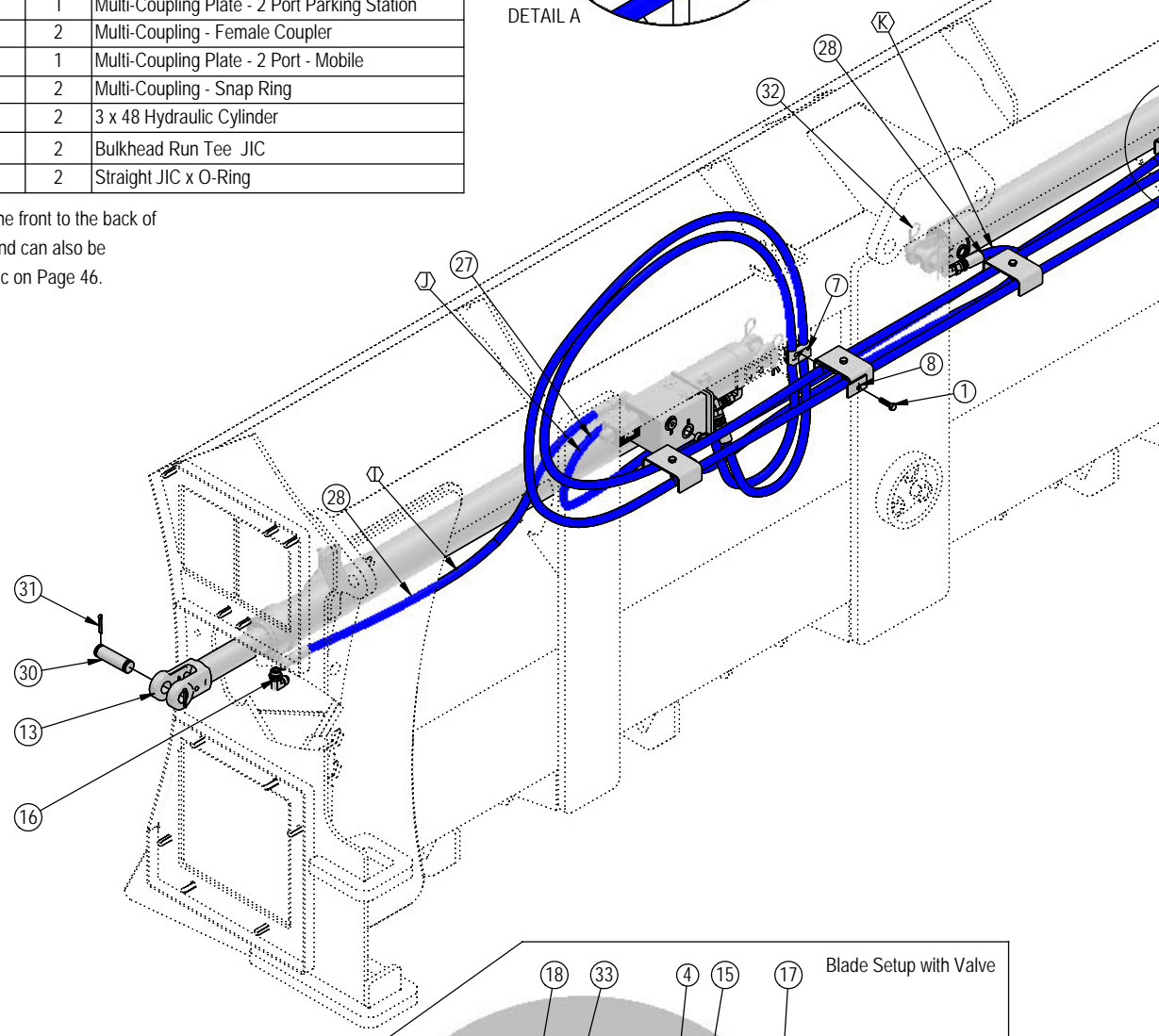

Note: The cylinder part number is stamped on the base end of the cylinder opposite of the hydraulic ports.

No. On Cylinder	Part No.	Description
26-34741	49-17797	Seal Kit 3" (649210)

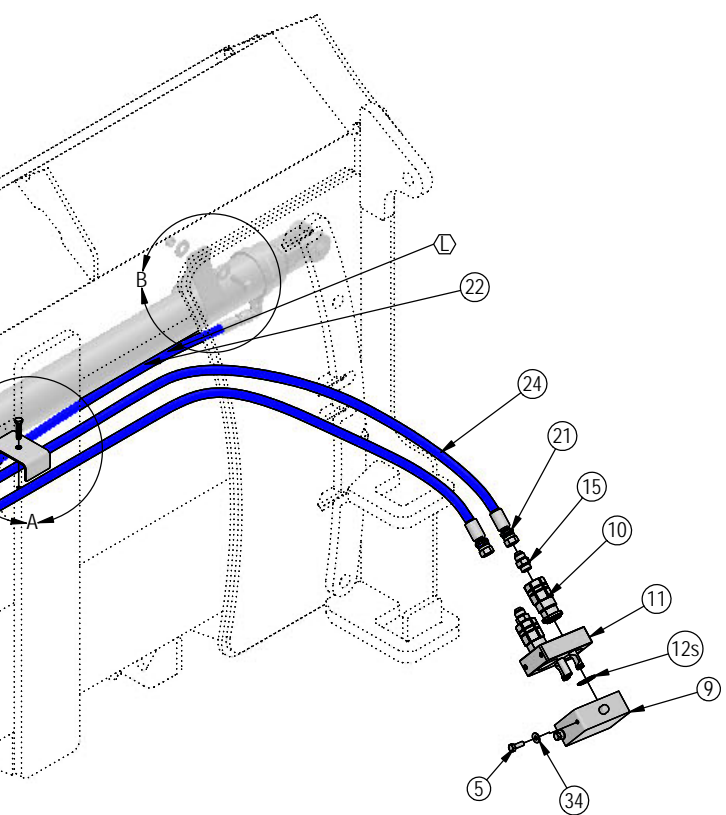

ITEM NO.	PART NO.	VALVE QTY.	TEE'D QTY.	DESCRIPTION
16	31-34050	6	4	Straight Thread Elbow 90° JIC x O-Ring
17	31-34100	2	2	Swivel Nut Elbow 90° JIC
18	31-34123	4	-	Hex Socket O-Ring Plug
19	31-34150	2	-	Straight Thread Elbow 45° JIC x O-Ring
20	34-17585R1	2	2	Cylinder Strap
21	34-18888-BL	6	6	-12 Blue - Spiral Band
22	35-11686-0560	1	-	56" x 3/8" -8JIC/-8JIC Hose
23	35-11686-0570	-	1	57" x 3/8" -8JIC/-8JIC Hose
24	35-11686-1870	2	2	187" x 3/8" -8JIC/-8JIC Hose
25	35-30003	-	1	18" x 3/8" -8JIC/-8JIC Hose
26	35-30008	-	1	23" x 3/8" -8JIC/-8JIC Hose
27	35-30019	1	-	34" x 3/8" -8JIC/-8JIC Hose
28	35-30022	2	-	39" x 3/8" -8JIC/-8JIC Hose
29	35-30032	-	1	69" x 3/8" -8JIC/-8JIC Hose
30	43-16306	4	4	Cylinder Pin w/ Cotter Pins
31	43-18943	4	4	3/16" x 1-1/2" Cotter Pin
32	43-7767	4	4	Cylinder Pin Clip
33	56-1492	1	-	1300 Electrical Valve
34	57-20740	2	2	1/4" Flat Washer
35	57-20744	4	4	1/2" Washer
36*	69-8884-200	1	-	Wire Harness
37	70-20604	2	2	1/2" Center Lock Hex Nut
38	70-20807	-	2	3/4" Hex Jam Nut NF

Blade Setup with Tee Fittings

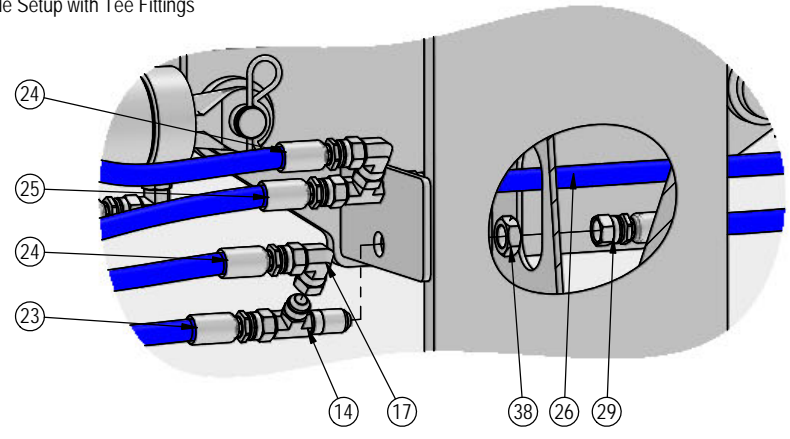

The Parts Not Shown Here Are The Same As The Setup with a Valve.

SCALE 1 : 6

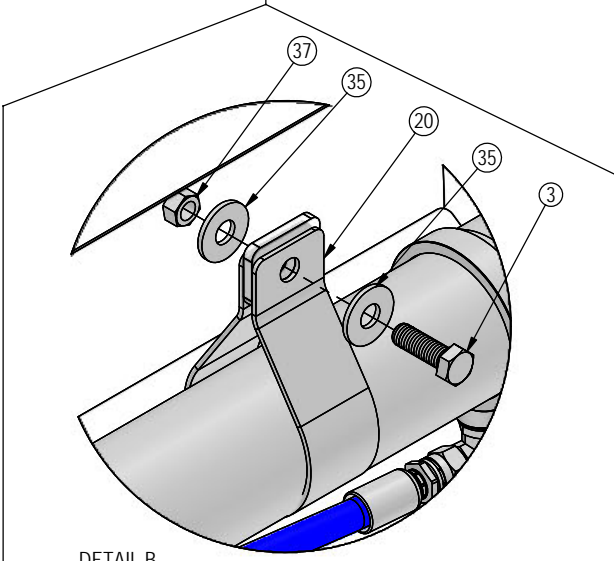

DETAIL B

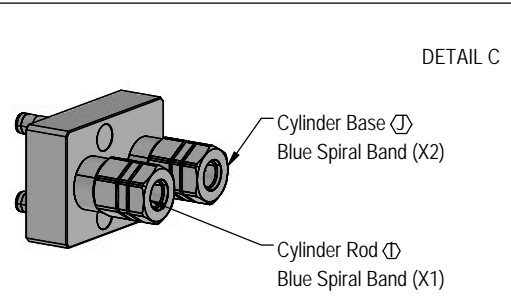

DETAIL C

**Note:** View is from Multi-Coupler Installed on Top Arm. All hoses are marked with colored spiral bands and should be attached to designated ports on the Multi-Coupler.

ITEM NO.	16480-K QTY.	16470-K/QTY.	PART NO.	DESCRIPTION
1	18	18	16-20542	7/8" x 3" Hex Bolt Gr 8 NC
2	2	-	44-16480	Silage Box End Plate
3	-	2	44-16470	Box End Plate
4	18	18	70-20598	7/8" Hex Nut Gr 8 NC

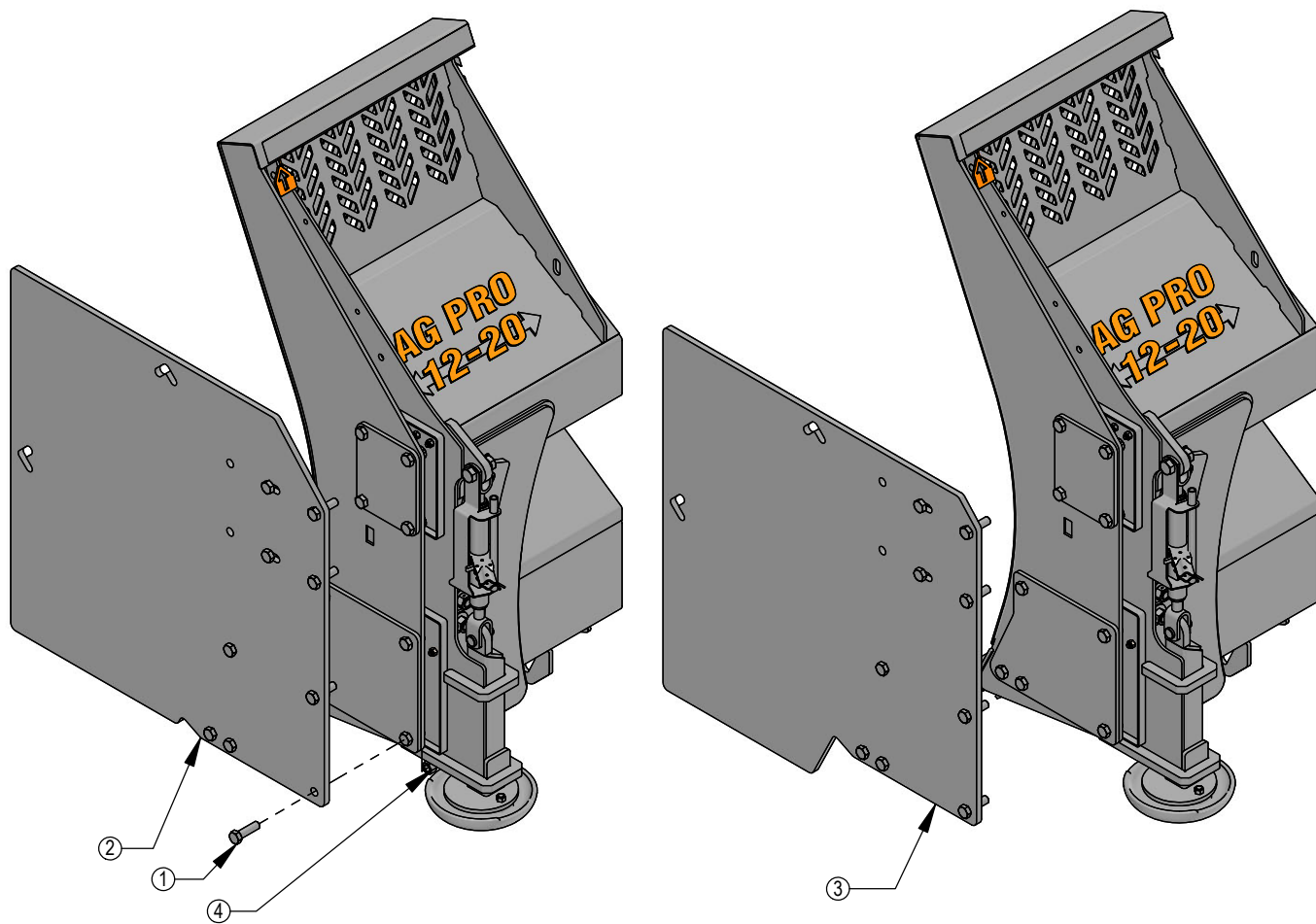

ITEM NO.	PART NO.	DESCRIPTION	15458-1K QTY.	15458-K QTY.
1	16-21666	5/8" x 1-3/4" Plow Bolt Gr 5 NC	2	4
2	50-15458	12" Round Mushroom Skid Shoe	1	2
3	70-20646	5/8" Hex Top Lock Nut Gr 5 NC	2	4

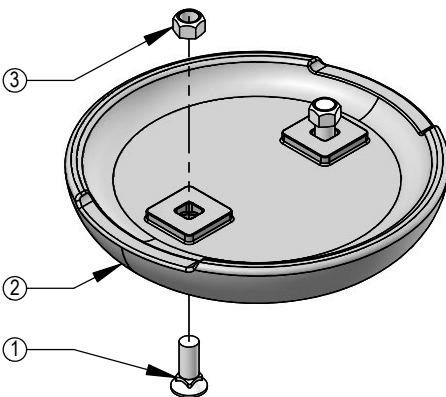



1. Lift the blade a comfortable distance off the ground for working on removing the cuttings edges. Block the lift system to prevent the blade from lowering while working on the blade.
2. Extend the ends out to gain access to the nuts.
3. Set parking bracket and shut off the engine.
4. Remove standoffs and hardware to allow the ends to be pulled away from the center blade section to gain access to the last 2 nuts on the blade ends
5. Remove all cutting edge hardware for the center section and both ends. The cutting edges on the ends need to be removed to gain access to the outer most hardware of the center section's cutting edges.
6. Either turn the cutting edges around, if it's the first time, or replace the cutting edges.
7. Reinstall all cutting edge hardware for the center section first and then reinstall hardware for the ends.
8. Reinstall the standoffs and hardware that were removed in Step #4.

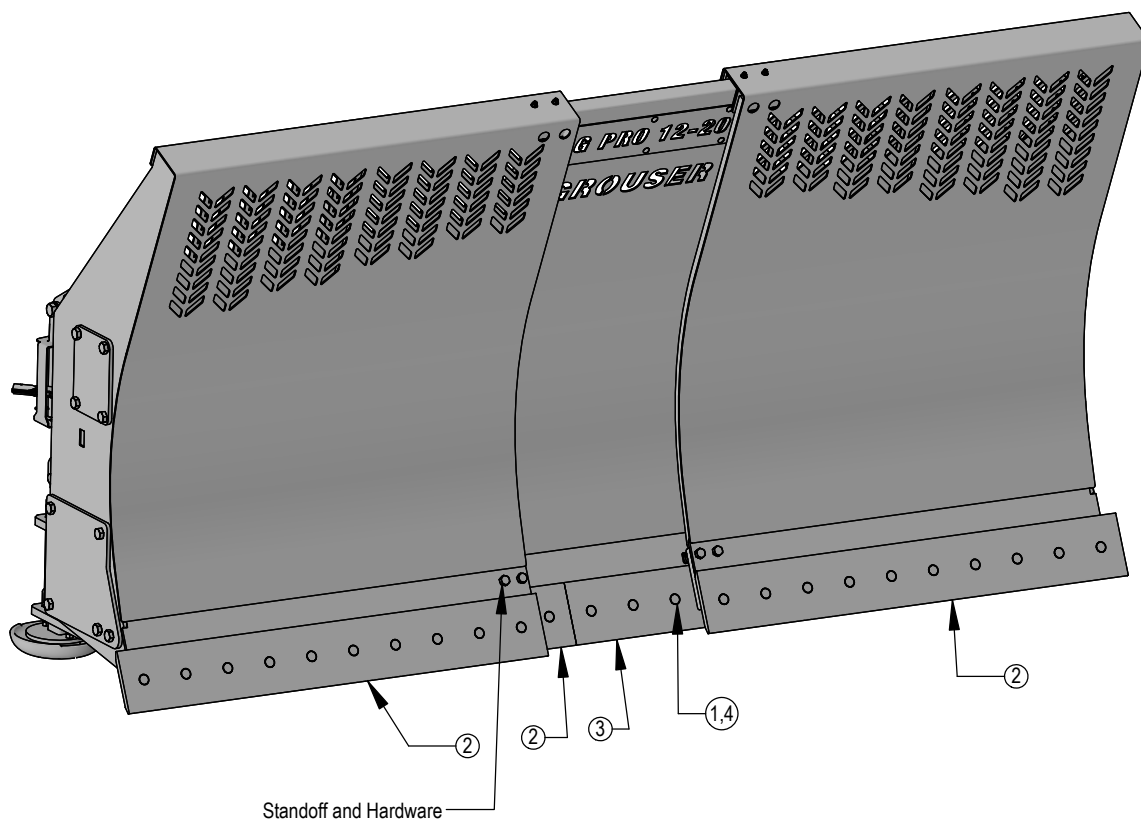

ITEM NO.	QTY.	PART NO.	DESCRIPTION
1	42	16-21748	3/4" X 2" Plow Bolt Gr 8 NC
2	3	29-11118-5	5' - 3/4"x 8" Cutting Edge
3	1	29-11118-6	6' - 3/4"x 8" Cutting Edge
4	42	70-20647	3/4" Hex Top Lock Nut Gr 5 NC

**Before Each Use:**

1. Disconnect the mobile half from the parking station and the cap from the fixed half.
2. Check that there is no contamination (salt, sand, dirt, etc.):
  - A. On the pins.
  - B. Inside the cam.
  - C. In the locking mechanism area.
  - D. On the face of the plates and couplings.
3. In case of contamination, remove it with a cloth and/or compressed air.
4. Check that there is still a lubricant/anti-corrosion (grease or silicone - see Note 1):
  - A. On the pins.
  - B. Inside the cam.
  - C. In the locking mechanism area.
5. Connect the mobile and fixed halves together.

**Fixed Half**

**Mobile Half**

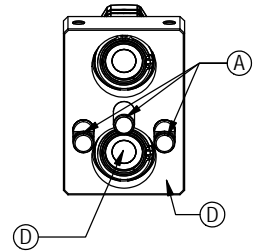
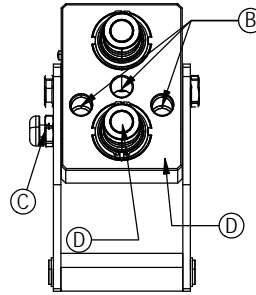

**After Each Use:**

1. Disconnect the mobile half from the fixed half.
2. Clean all contamination (salt, sand, dirt, etc.) from the following areas:
  - A. On the pins.
  - B. Inside the cam.
  - C. In the locking mechanism area.
  - D. On the face of the plates and couplings.

\*Use a cloth or compressed air. It is advised to not use water to clean these surfaces
3. Apply a lubricant/anti-corrosion (grease or silicone - see Note 1):
  - A. On the pins.
  - B. Inside the cam.
  - C. In the locking mechanism area.
4. Connect the cap to the fixed half and the mobile half to the parking station.

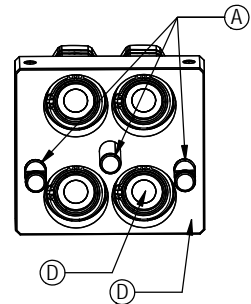
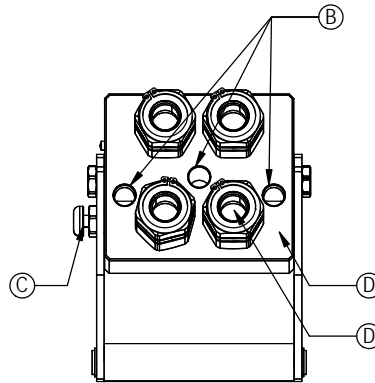

**Note 1:**

When sand and salt are present, or the plates under go a washdown, a heavy duty silicone spray lubricant should be used to replace grease from the factory. The lubricant should help protect from corrosion without collecting dust and contaminants, and will resist washing off when exposed to water.

**Recommended Lubricant Brands:**

Fluid Film (Aerosol or Non-Aerosol), LPS-2 Heavy Duty Lubricant, or CRC 3-36.

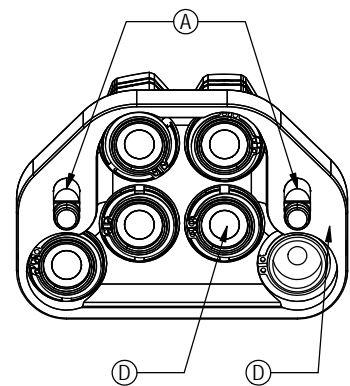
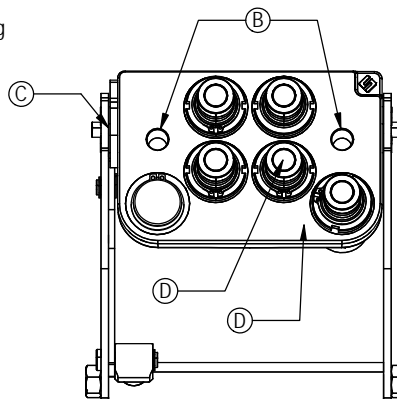

**Cleaning The Male Interface Seal:**



1. Make sure the coupling is securely fastened into the plate or place in a vice.
2. Using a blunt, non-marring tool, depress the valve face until the seal is exposed. Insert a bent metal wire between the valve face and the body of the coupling. Use caution not to damage or scratch the seal when inserting the wire.
3. Inspect the seal and interior surfaces for contamination.
4. In case of contamination, carefully wipe surfaces with a soft cloth, or use compressed air to blow the contamination out. Do Not press hard on the seal as contamination can scratch the seal surface.
5. Using a non-marring tool, depress the valve face and remove the metal wire. Release the valve to the flush position.

**Cleaning The Female Bushing:**

1. Make sure the coupling is securely fastened into the plate or place in a vice.
2. Using a non-marring tool, depress the outer ring to expose the bushing. There is no need to expose the valve seal, so stop pressing before the valve is opened.
3. Inspect the interior body and bushing surfaces for contamination.
4. In case of contamination, carefully wipe surfaces with a soft cloth, or use compressed air to blow the contamination out.
5. Release the outer ring so that it returns to the flush position.

Colored Lines = Quantity of Colored Spiral Bands

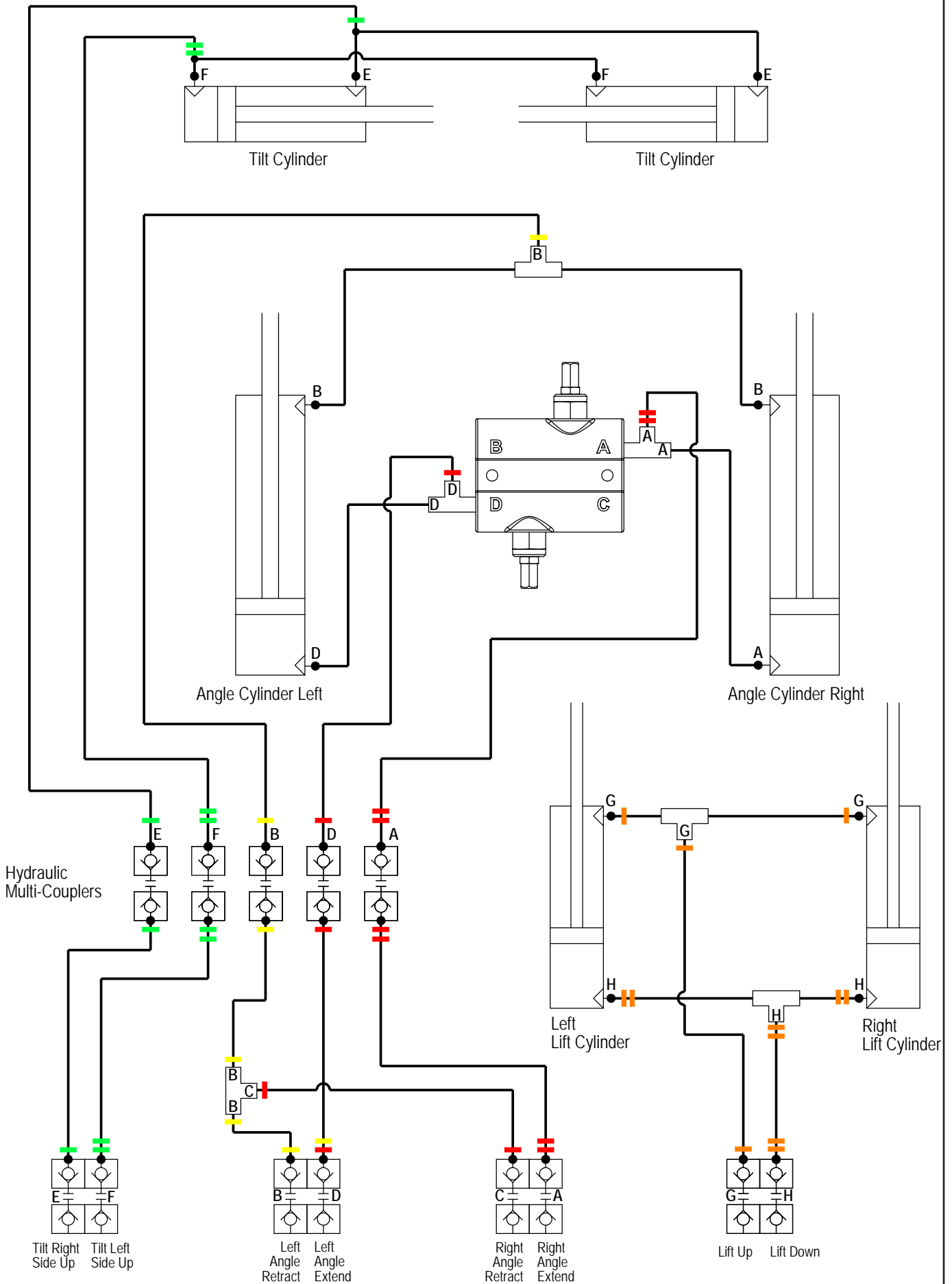

Tractor Service Valve

Colored Lines = Quantity of Colored Spiral Bands

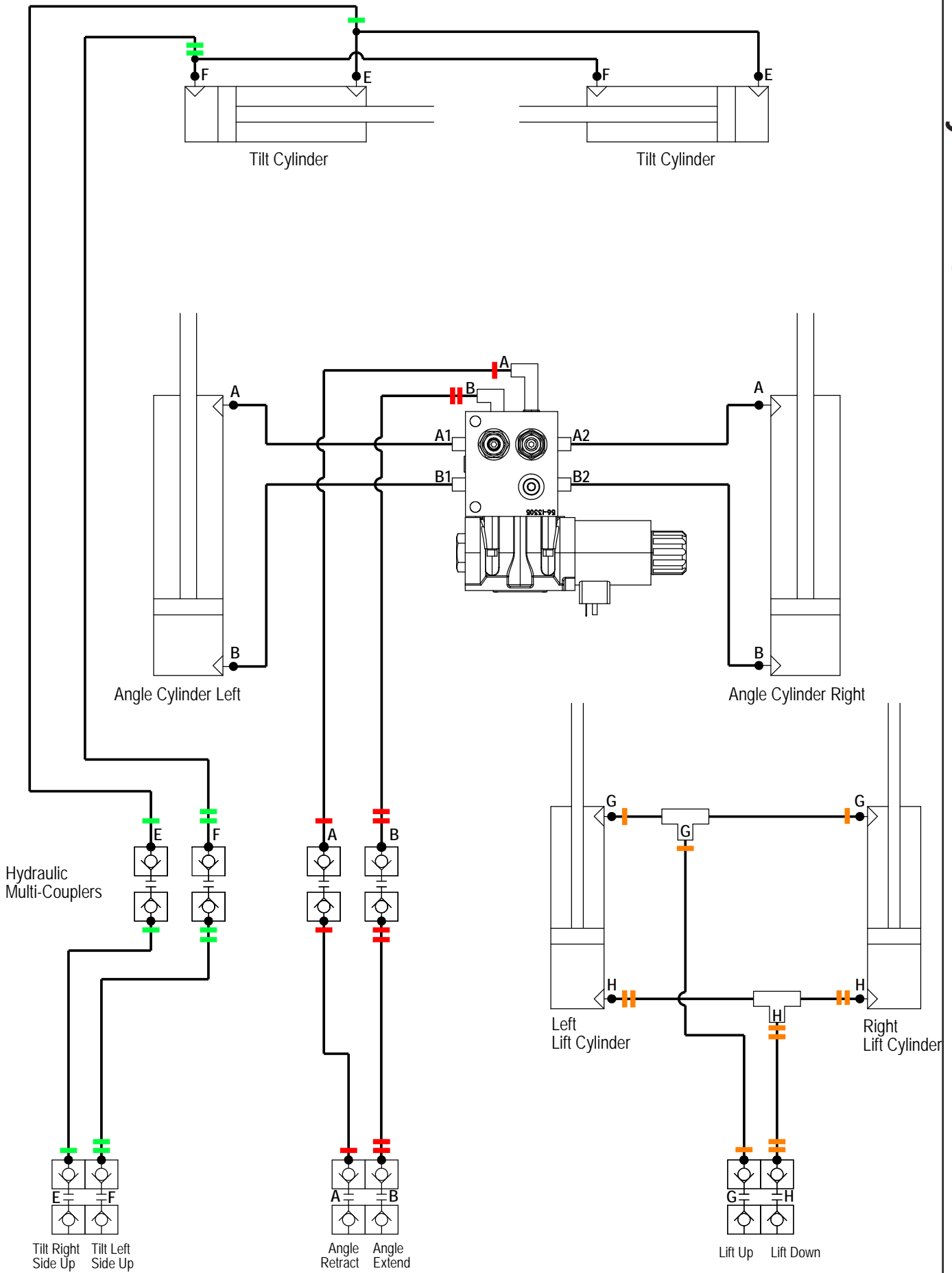

Tractor Service Valve

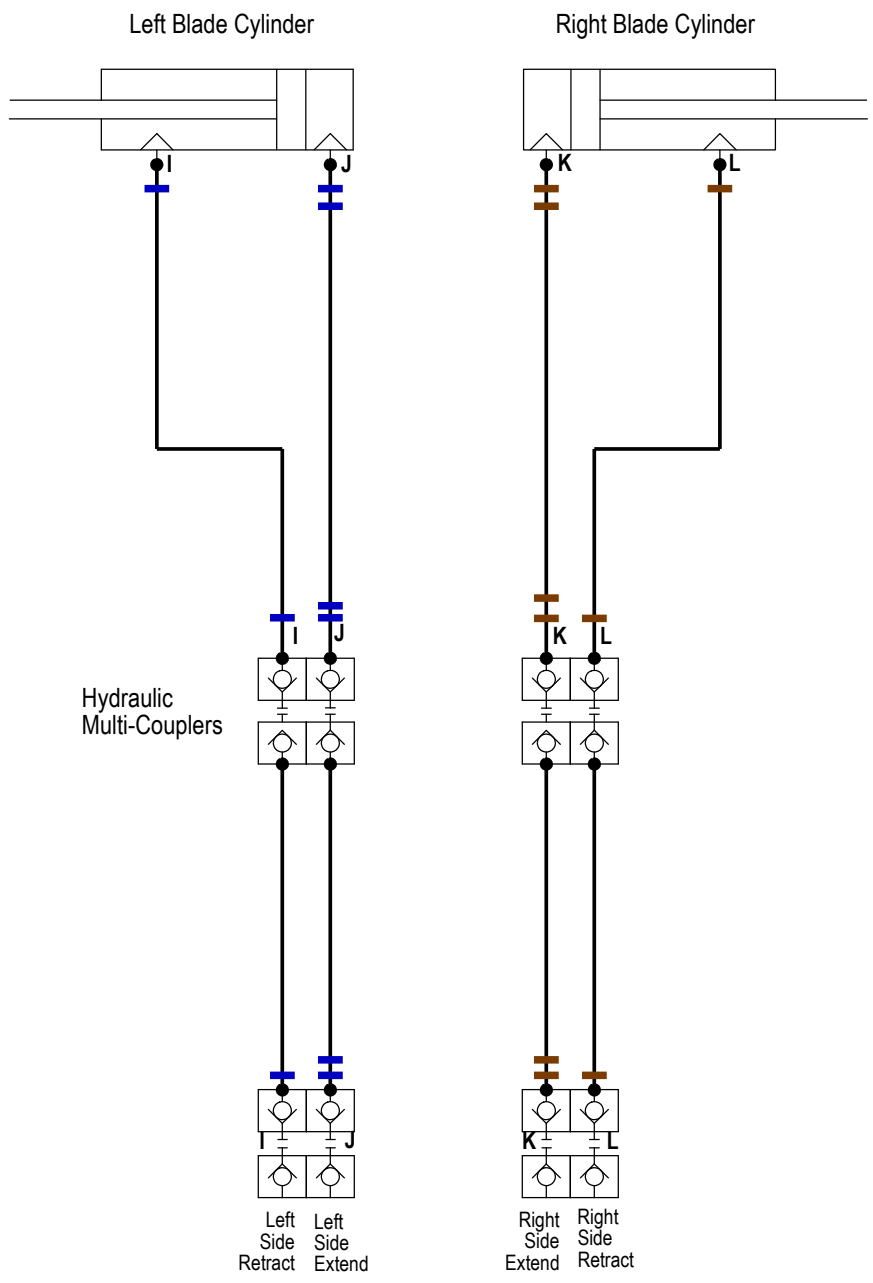

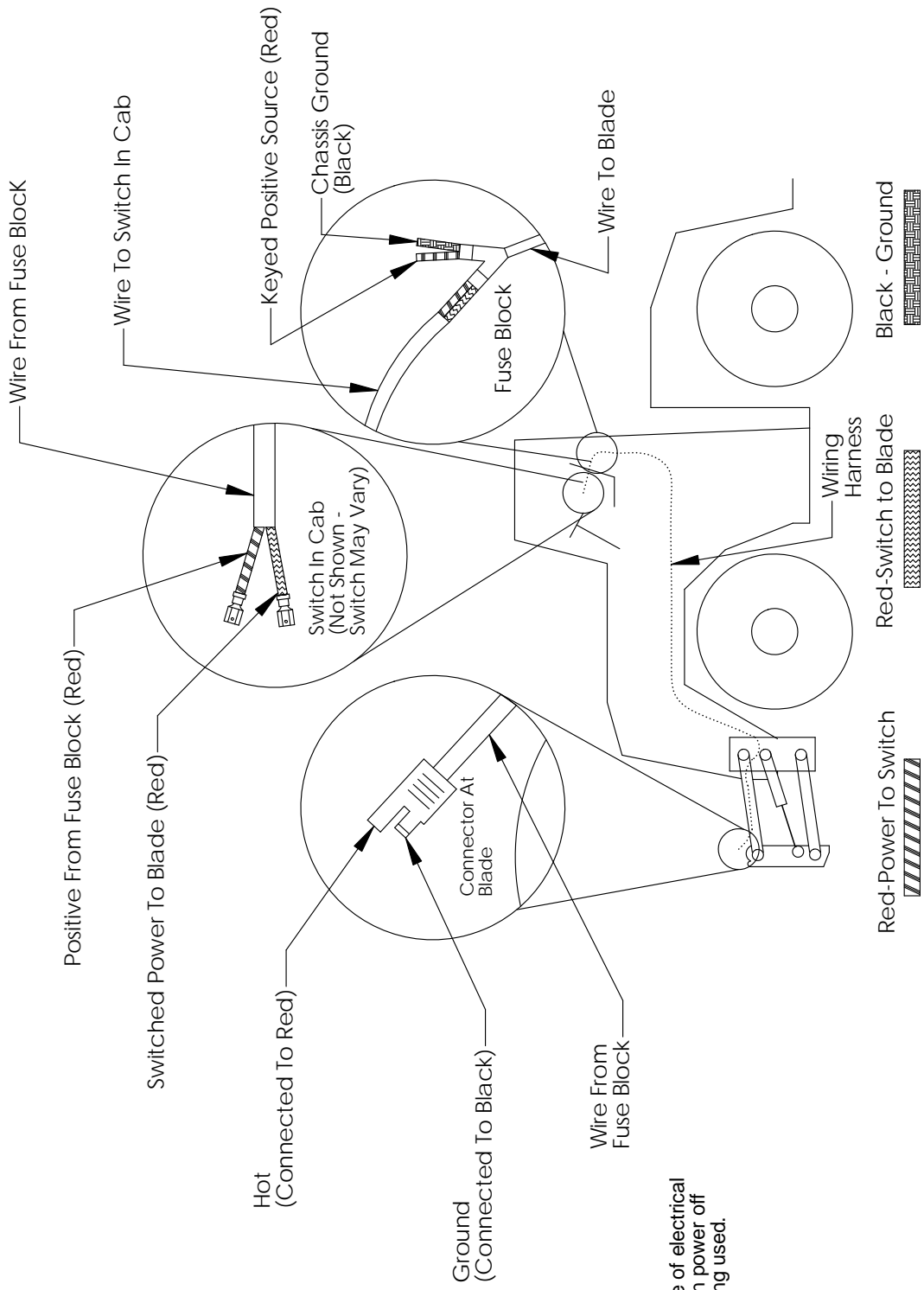

Note: To maximize life of electrical system and valve, turn power off when dozer is not being used.

**Instructions**

1. Locate "keyed and fused" 12 V power supply in cab of tractor.
2. Disconnect battery.
3. Connect the red wire to power and the black wire to ground.
4. Install switch in convenient place in cab.
5. Route wire harness from switch to the blade. (plug-in connector at blade)
6. Connect the switch to the wire harness.
7. Reconnect the battery.

# Contact Us

---

---

As always, if you have any questions about your 12-20 Dozer or other products made by Grouser, feel free to contact us.

## Grouser Products

755 2nd Ave NW - West Fargo, ND 58078

Phone: 1-800-747-6182

Fax: 1-701-282-8131

E-mail: [grouser@grouser.com](mailto:grouser@grouser.com)

Website: [www.grouser.com](http://www.grouser.com)

## Improvements

---

---

Grouser Products Inc. is continually striving to improve its products. We reserve the right to change prices, specification, or equipment at any time without notice. We also reserve the right to make improvements or changes when it becomes practical and possible to do so without incurring any obligation to make changes or additions to the equipment sold previously.

## Warranty

---

---

Grouser Products warrants to the original purchaser of each item that the product be free from defects in material and workmanship under normal use and service for a period of two years. If such equipment is found to be defective within two years, it is the obligation of Grouser Products under this warranty to repair or replace (exclusive of the cost of labor and transportation), any equipment or parts, in the judgment of Grouser Products to be defective in material or workmanship.

All equipment or parts claimed to be defective in material or workmanship must be made available for inspection at the place of business of a dealer authorized to handle the equipment covered by this warranty, or, upon request by Grouser Products, shipped to the Grouser Products factory in West Fargo, North Dakota. Grouser Products shall have no obligation to bear the cost of labor or transportation in connection with replacement or repair of any such defective parts in the setup process.

This warranty covers only defects in material and workmanship. It does not cover depreciation or damage caused by normal wear, accident, improper assembly, improper adjustments, improper maintenance including lack of proper lubrication, or improper use. Therefore, Grouser Products liability under this warranty shall not be effective or actionable unless the equipment is assembled, maintained and operated in accordance with the operating instructions accompanying the equipment. Grouser Products shall have no liability if the equipment has been altered or reworked without the written authorization of Grouser Products.

Grouser Products' parts, which are furnished under this warranty and properly installed, shall be warranted to the same extent as the original parts under this warranty if, and only if, such parts are found to be defective within the original warranty period covering the original equipment.

