

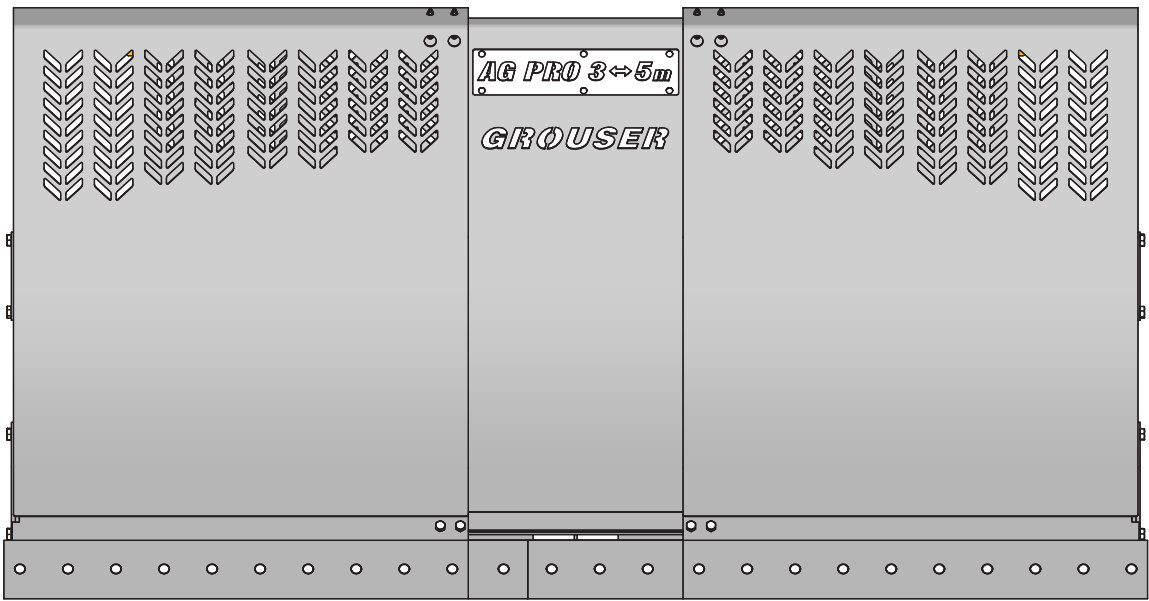

Ag Pro 3-5

Owner's Manual & Parts Book



Grouser Products
755 2nd Ave NW - West Fargo, ND 58078
Phone: 1-800-747-6182
Fax: 1-701-282-8131
E-mail: grouser@grouser.com
Website: www.grouser.com

Purchase Date
Serial Number
Model Number
Tractor Model
Dealer

Description	Page
Welcome To The Owner	2
Safety Precautions, Torque Specifications & Pre-Installation	3
Standard Lift System & Nested Top Arm Lift System	4-5
Tractor Side Hydraulics	6-9
Initial Startup	10
Blade Connection and Disconnection	11
Lift Speed Control Installation	12
Skid Shoe Adjustment & Tilt Plate Adjustment	13
Ag Pro 3-5 Blade	14-15
Hydraulic Angle-Hydraulic Tilt and Hydraulic Angle-No Tilt System	16-17
Hydraulic Angle-Hydraulic Tilt Hydraulics	18-19
Hydraulic Angle-No Tilt Hydraulics	20-21
No Angle-Hydraulic Tilt System	22-23
Hydraulic Angle Blade Hydraulics	24-25
NANT System	26-27
NAHT Blade Hydraulics	28
Hydraulic Schematics	29-30
Hydraulic Multi-Coupler Maintenance	31-32
Notes	33-35
Contact Us, Improvements, & Warranty	36

Thank you for your recent purchase of a Grouser Ag Pro 3-5 Dozer. Welcome to the family of satisfied Grouser blade owners. Grouser Products is committed to offering quality products to help professionals in their daily jobs. We are also committed to providing you the highest level of customer satisfaction possible. Again, thank you for your patronage. We look forward to serving you.

This manual contains information concerning the operation, adjustment, safety and maintenance of the Ag Pro 3-5 Dozer. You have purchased a dependable, long lasting piece of equipment. You can expect to receive long lasting performance and long service built into our products with proper care and operation. Please have all operators read and understand this manual carefully. Keep the manual available for reference. If, for any reason, you have questions or comments, we would be happy to hear from you. Call our toll-free number, 701-282-7710, or send us an e-mail at info@grouser.com. You can expect us to respond to your e-mail in a timely manner.

HAHT	Hydraulic Angle - Hydraulic Tilt
HANT	Hydraulic Angle - No Tilt
NAHT	No Angle - Hydraulic Tilt
NANT	No Angle - No Tilt

A careful operator is the best operator. Most accidents can be avoided by observing certain precautions. To help prevent accidents, read and take the following precautions before operating this equipment. In addition, please follow all safety and operational instructions of your tractor manufacturer.

The Ag Pro 3-5 Dozer:

1. The Ag Pro 3-5 Dozer should be operated only by those who are responsible and instructed to do so.
2. Read the owner's manual carefully before using this equipment. Lack of operating knowledge can lead to accidents.
3. Keep the Ag Pro 3-5 Dozer maintained in reliable and satisfactory condition to ensure your safety.
4. Make sure the area is clear of people before moving any equipment.
5. Do not modify or permit anyone else to modify or alter the equipment and its components without first consulting Grouser Products.
6. Lower the blade to the ground when not in use.

Servicing the Ag Pro 3-5 Dozer:

1. Read and follow all safety instructions provided by the tractor manufacturer.
2. Always use proper personal safety gear when performing maintenance on equipment.
3. Before servicing, relieve hydraulic pressure, stop engine and fully engage parking brake.
4. Escaping hydraulic fluid under pressure can penetrate skin causing serious injury. If fluid is injected into skin, obtain medical attention immediately.
 - DO NOT use your hand to check for leaks. Use a piece of cardboard or paper to search for leaks.
 - Stop the engine and relieve pressure before connecting or disconnecting lines.
 - Tighten all connections before starting the engine or pressurizing lines.

Storing the Ag Pro 3-5:

1. Thoroughly clean the Ag Pro 3-5 Dozer before storage. Use paint where necessary to prevent rust.
2. Check the Ag Pro 3-5 Dozer for worn or damaged parts. Install new parts as required.
3. Lubricate all pins and joints.

Tighten all bolts to the values listed below unless otherwise noted. Refer to the parts lists for proper length and grade of the bolts.

Size	Torque - Dry (ft-lbs)			
	SAE Grade 5		SAE Grade 8	
	UNC	UNF	UNC	UNF
5/16	17	19	24	27
3/8	30	35	45	50
7/16	50	55	70	80
1/2	75	85	110	120
9/16	110	120	150	170
5/8	150	170	210	240
3/4	260	300	380	420
7/8	430	470	600	670
1	640	720	910	1020

Size	Torque - Dry (ft-lbs)
	Grade 10.9
M18 x 2.50	284
M20 x 2.50	401
M22 x 2.50	547
M24 x 3.00	694

Unstrap and remove the lift frame, hoses, top arms, and any boxes of hardware from the undercarriage. If any components are missing, call Grouser.

Install undercarriage per the tractor specific mounting instructions.

Some assembly of Lift System components is necessary. Follow the steps listed below. See diagram below for the correct hardware and orientation of parts.

1. Remove all pins and fasteners on each side of the undercarriage and set aside for later installation.
2. Position the lift frame between the two plates on both sides of the undercarriage and align to the bottom holes.
3. Insert pins and hardware to attach the lift frame, the base end of the lift cylinders, and the top arms to the undercarriage.
4. Insert pins and hardware to attach the male quick attaches to the lift frame, and to the top arms. Use 2" washers as shims to keep top arm pins tight and in place. Only use as many as needed until pin is tight.
5. Torque all fasteners according to the specifications on Page 3.

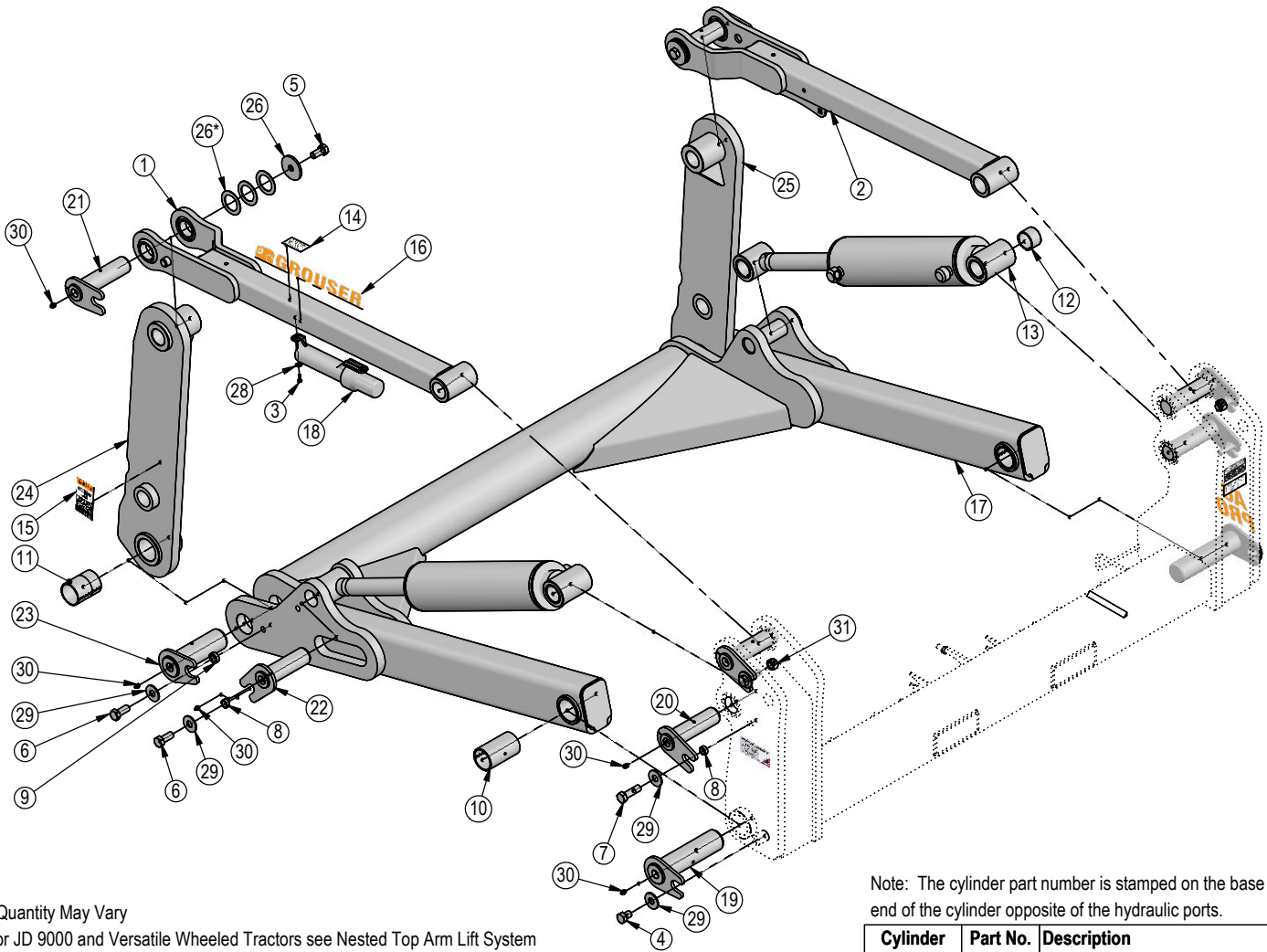

Note: The cylinder part number is stamped on the base end of the cylinder opposite of the hydraulic ports.

* Quantity May Vary

For JD 9000 and Versatile Wheeled Tractors see Nested Top Arm Lift System

ITEM NO.	QTY.	PART NO.	DESCRIPTION
1	1	11-19975-L	Top Arm Weld
2	1	11-19975-R	Top Arm Weld
3	2	16-20002	1/4" X 3/4" Hex Bolt Gr 5 NC CZ
4	2	16-20214	3/4" X 1" Hex Bolt Gr 5 NC CZ
5	2	16-20216	3/4" X 1-1/2" Hex Bolt Gr 5 NC CZ
6	4	16-20217	3/4" X 1 3/4" Hex Bolt Gr 5 NC CZ
7	4	16-20220	3/4" X 2-1/2" Hex Bolt Gr 5 NC CZ
8	6	19-13515	Spacer, NR Pin
9	2	19-43989	.75 x 1.25 NR Pin Bushing
10	2	19-13525	2.75 x 2.50 x 4.75 Spring Bushing
11	2	19-18089	2.75 x 2.50 x 3.75 Spring Bushing
12	8	19-16695	2.25 x 2.00 x 1.50 Spring Bushing
13	2	26-34751	5 x 18 Hydraulic Cylinder
14	1	27-40962	Warning Prop 65 Decal
15	2	27-9503	Pinch Decal (Foot)
16	2	27-9504	Grouser Horizontal Decal

Cylinder	Part No.	Description
26-34751	49-12275	Seal Kit 5 x 18 Nitrided Rod

ITEM NO.	QTY.	PART NO.	DESCRIPTION
17	1	32-42335	Lift Frame
18	1	34-14961	Manual Canister Small
19	2	43-14725	Lift Frame / UC Pin
20	4	43-18120	Top Pin Weld
21	2	43-18127	Top Arm Pin Weld
22	2	43-18175	Lift Cyl Pin Weld
23	2	43-18635	Ag Pro Plus QA Pin
24	1	45-18110-L	Male Quick Attach, Ag Pro S - Left
25	1	45-18110-R	Male Quick Attach, Ag Pro S - Right
26	2	57-1530	3/4" x 3".00 x .25" HD Washer CZ
27*	6	57-1811	2" Washer
28	2	57-20740	1/4" Flat Washer CZ
29	10	57-20747	3/4" Flat Washer CZ
30	12	58-9369	Straight 1/8" NPT Grease Zerk
31	2	70-20607	3/4" Hex Center Lock Nut Gr 5 NC CZ

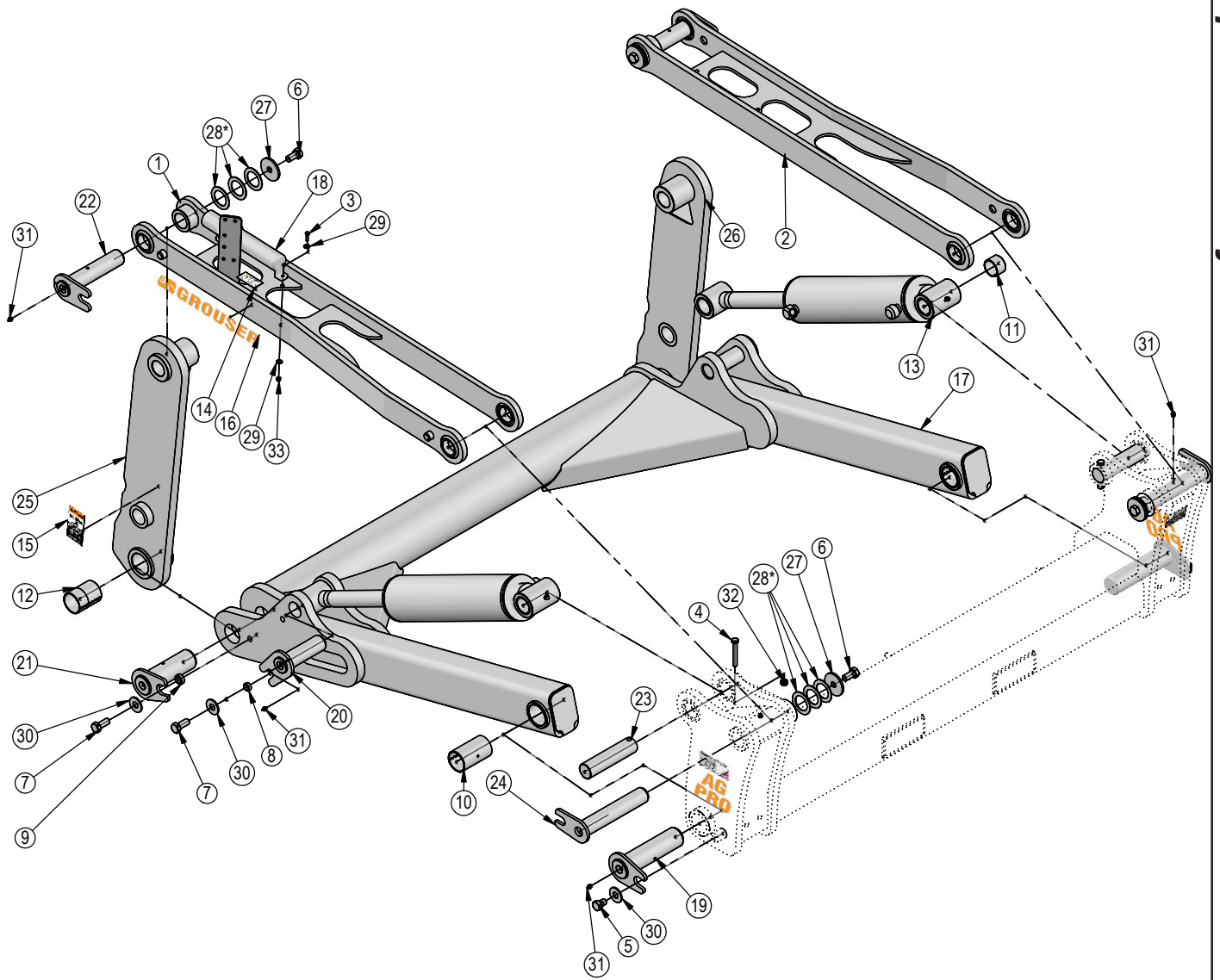

* Quantity May Vary

Note: The cylinder part number is stamped on the base end of the cylinder opposite of the hydraulic ports.

ITEM NO.	QTY.	PART NO.	DESCRIPTION
1	1	11-19035-L	Nested Top Arm Weld
2	1	11-19035-R	Nested Top Arm Weld
3	2	16-20004	1/4" X 1" Hex Bolt Gr 5 NC CZ
4	2	16-20134	1/2" X 3-1/2" Hex Bolt Gr 5 NC CZ
5	2	16-20214	3/4" X 1" Hex Bolt Gr 5 NC CZ
6	4	16-20216	3/4" X 1-1/2" Hex Bolt Gr 5 NC CZ
7	4	16-20217	3/4" X 1 3/4" Hex Bolt Gr 5 NC CZ
8	2	19-13515	Spacer, NR Pin
9	2	19-43989	.75 x 1.25 NR Pin Bushing
10	2	19-13525	2.75 x 2.50 x 4.75 Spring Bushing
11	8	19-16695	2.25 x 2.00 x 1.50 Spring Bushing
12	2	19-18089	2.75 x 2.50 x 3.75 Spring Bushing
13	2	26-34752	5 x 18 Hydraulic Cylinder With Zerk
14	1	27-40962	Warning Prop 65 Decal
15	2	27-9503	Pinch Decal (Foot)
16	2	27-9504	Grouser Horizontal Decal
17	1	32-42335	Lift Frame
18	1	34-14961	Manual Canister Small

Cylinder	Part No.	Description
26-34751	49-12275	Seal Kit 5 x 18 Nitrided Rod

ITEM NO.	QTY.	PART NO.	DESCRIPTION
19	2	43-14725	Lift Frame / UC Pin
20	2	43-18175	Lift Cyl Pin Weld
21	2	43-18635	Ag Pro Plus QA Pin
22	2	43-19040	Top Arm - Quick Attach Pin Weld
23	2	43-19041	Pin, Lift Cylinder
24	2	43-19043	Top Arm - Undercarriage Pin Weld
25	1	45-18110-L	Male Quick Attach, Ag Pro S
26	1	45-18110-R	Male Quick Attach, Ag Pro S
27	4	57-1530	3/4" x 3".00 x .25" HD Washer CZ
28*	12	57-1811	2" Washer
29	4	57-20740	1/4" Flat Washer CZ
30	6	57-20747	3/4" Flat Washer CZ
31	10	58-9369	Straight 1/8" NPT Grease Zerk
32	2	70-20604	1/2" Hex Center Lock Nut Gr 5 NC CZ
33	2	70-20610	1/4" Nylock Hex Nut Gr 5 NC CZ

ITEM NO.	PART NO.	HAHT QTY.	HANT QTY.	NAHT QTY.	NANT QTY.	DESCRIPTION
1	16-20124	2	2	2	-	1/2" x 1" Hex Bolt Gr 5 NC
2	16-812525	2	2	2	-	8mm x 1.25mm x 25mm Metric Hex Bolt Gr 10.9
3	18-19995-L	1	1	1	-	Multi-Coupler Mount
4*	25-19868	-	1	1	-	Multi-Coupling Plate - 2 Port - Fixed
5*	25-19871	-	1	1	-	Multi-Coupling Plate - 2 Port - Cap
6	25-19864	1	-	-	-	Multi-Coupling Plate - 4 Port Fixed
7	25-19867	1	-	-	-	Multi-Coupling Plate - 4 Port - Cap
8	25-19870	4	2	2	-	Multi-Coupling Plate - Male Coupler
9	25-34342	6	4	4	2	Tappet Quick Coupler Male - Poppet Style
10	25-3453	2	-	2	-	Pioneer Dust Cap Tilt (Green)
11	25-3455	2	2	-	-	Pioneer Dust Cap Angle (Red)
12	25-3457	2	2	2	2	Pioneer Dust Cap Lift (Orange)
13	25-40407	4	2	2	-	Multi-Coupling Plate - Snap Ring
14	31-11699-10-10	2	2	2	2	JIC Union
15	31-15199-8-8	4	2	2	-	JIC Union Elbow 90°
16	31-34032	2	2	2	2	Bulkhead Run Tee JIC
17A,B	31-34051	4	2	2	-	Straight Thread Elbow 90° JIC x O-Ring
17C*	31-6802-08-10	4	2	2	-	Straight Thread Elbow 45° JIC x O-Ring
18A,B	31-34059	2	2	2	2	Straight Thread Elbow 90° JIC x O-Ring
18C*	31-6802-12-10	2	2	2	2	Straight Thread Elbow 45° JIC x O-Ring
19	31-34150	4	2	2	-	Straight Thread Elbow 45° JIC x O-Ring

* Part Not Shown

Hoses Not Drawn to Scale

Item A for CNH, JD 9R, JD 9030

Item B for Versatile, Challenger MT900 and JD 9RX

Item C for Claas Xerion Tractor

Item #1, 3 and 33 not used with Nested Top Arm Lift Systems

HAHT Shown. See Page 9 for remaining Multi-Coupler Configurations.

Every hydraulic function from the front to the back of the system is designated by a \odot and a letter and can also be referenced on the Hydraulic Schematic on Page 29-30.

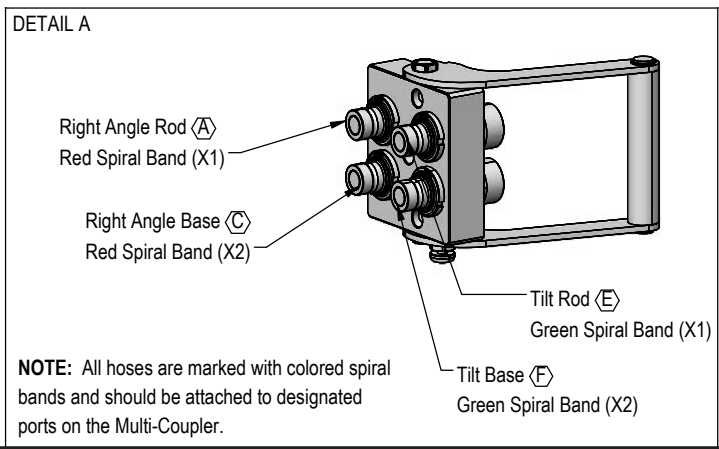
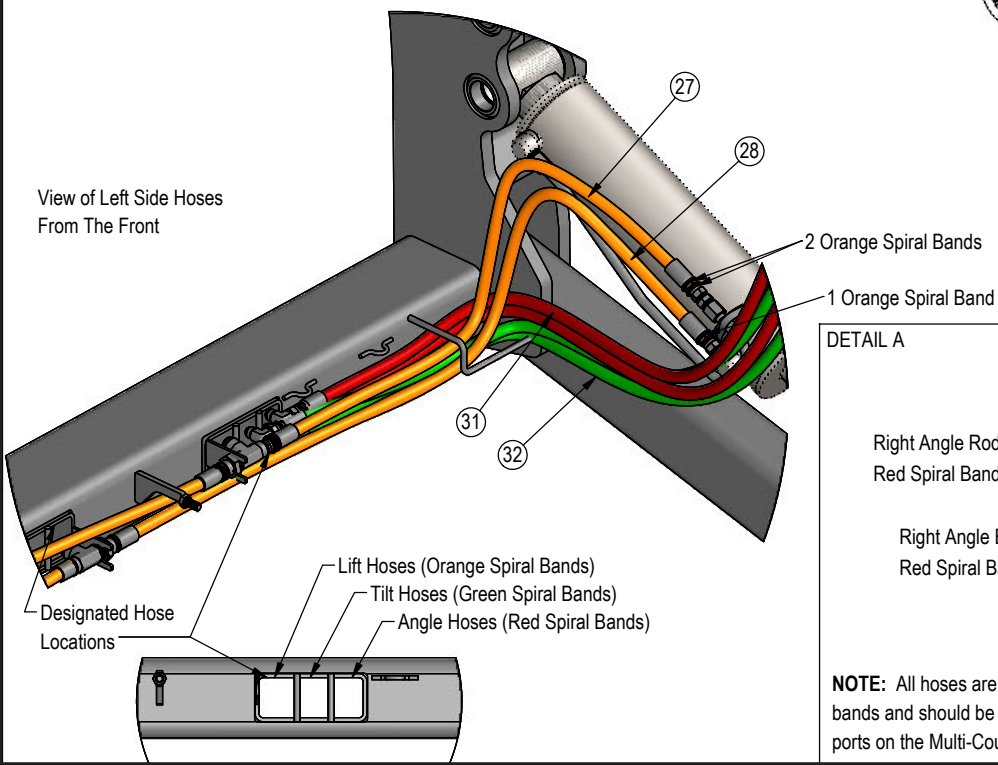
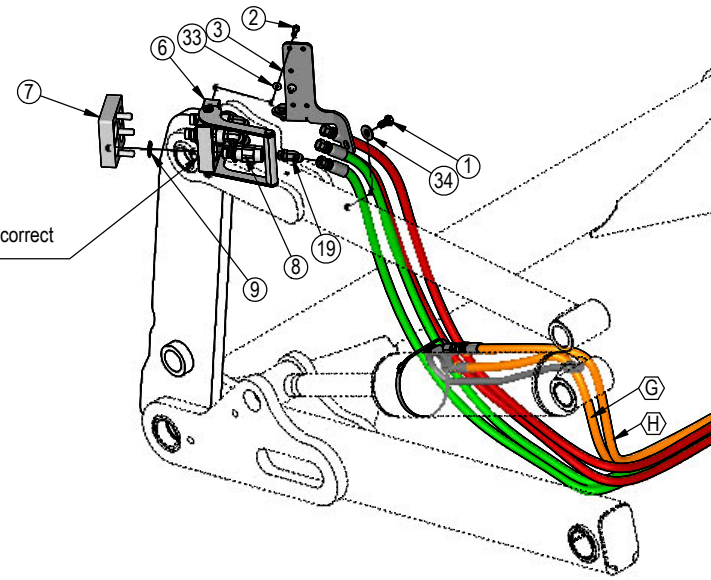

ITEM NO.	PART NO.	HAHT QTY.	HANT QTY.	NAHT QTY.	NANT QTY.	DESCRIPTION
20	31-34042	4	4	4	4	Straight JIC x O-Ring
21	34-12932	2	2	2	2	Cylinder Saddle
22	34-12933	2	2	2	2	Hose Clamp (worm drive - 5)
23	34-18888-GR	9	-	9	-	-12 Green - Spiral Band
24	34-18888-RD	9	9	-	-	-12 Red - Spiral Band
25	34-19494-OR	15	15	15	15	-16 Orange - Spiral Band
26A,C	35-12329-3000	2	2	2	2	300" (25") x 3/4" -12JIC/-12JIC Hose w/ Cordura
26B	35-12329-3200	2	2	2	2	320" (26.67") x 3/4" -12JIC/-12JIC Hose w/ Cordura
27	35-12636-0535	2	2	2	2	53.5" x 5/8" -10JIC/-12JIC Hose w/ Cordura
28	35-12636-0670	2	2	2	2	67" x 5/8" -10JIC/-12JIC Hose w/Cordura
29	35-18240	2	2	2	2	Lift Cylinder Steel Line
30A,C	35-30183	4	2	2	-	293" (24.42") x 1/2" -8JIC/-8JIC Hose w/ Cordura
30B	35-18953-3200	4	2	2	-	320" (26.67") x 1/2" -8JIC/-8JIC Hose w/ Cordura
31	35-31135	2	2	-	-	78" x 1/2" -8JIC/-8JIC Hose w/Cordura
32	35-31136	2	-	2	-	81" x 1/2" -8JIC/-8JIC Hose w/Cordura
33	57-20740	2	2	2	-	1/4" Flat Washer
34	57-20744	2	2	2	-	1/2" Washer
35	70-20809	2	2	2	2	1-1/16" Hex Jam Nut

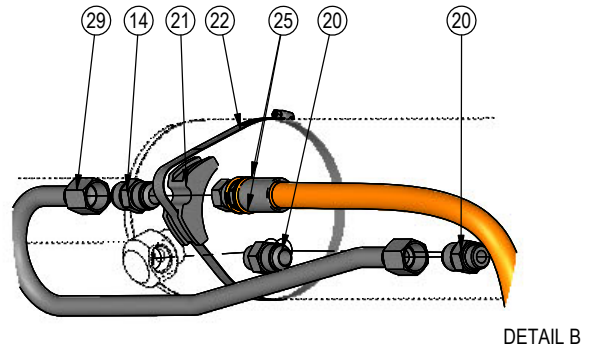
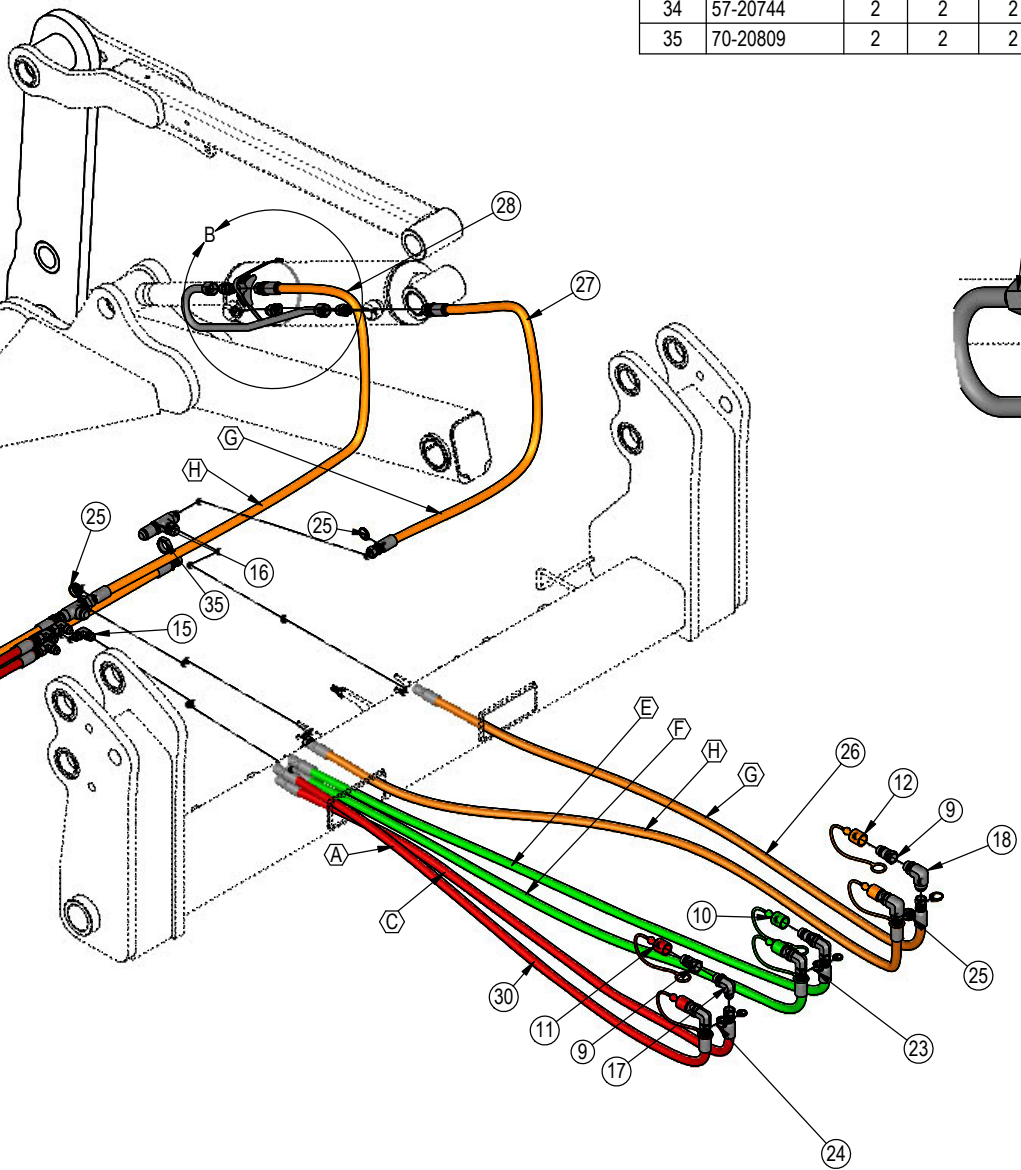

DETAIL B

ITEM NO.	SINGLE CONTROL QTY.	DUAL CONTROL QTY.	PART NO.	DESCRIPTION
1	2	2	16-20124	1/2" x 1" Hex Bolt Gr 5 NC
2	2	2	16-812525	8mm x 1.25mm x 25mm Metric Hex Bolt Gr 10.9
3	1	1	18-19995-R	Multi-Coupler Mount
4	-	1	25-19864	Multi-Coupling Plate - 4 Port Fixed
5	-	1	25-19867	Multi-Coupling Plate - 4 Port - Cap
6	1	-	25-19868	Multi-Coupling Plate - 2 Port - Fixed
7	1	-	25-19871	Multi-Coupling Plate - 2 Port - Cap
8	2	4	25-19870	Multi-Coupling Plate - Male Coupler
9	2	4	25-40407	Multi-Coupling Plate - Snap Ring
10	2	4	25-34342	Tappet Quick Coupler Male - Poppet Style
11	2	2	25-3403	Pioneer Dust Cap Slider (Blue) (Left Cylinder)
12	-	2	25-3405	Pioneer Dust Cap Slider (Brown) (Right Cylinder)
13	2	4	31-15199-8-8	JIC Union Elbow 90°
14	2	4	31-34051	Straight Thread Elbow 90° JIC x O-Ring
15	2	4	31-34150	Straight Thread Elbow 45° JIC x O-Ring
16	9	9	34-18888-BL	-12 Blue - Spiral Band
17	-	9	34-18888-BR	-12 Brown - Spiral Band
18A,C	2	4	35-30183	293" (24.42") x 1/2" -8JIC/-8JIC Hose
18B	2	4	35-18953-3200	320" (26.67") x 1/2" -8JIC/-8JIC Hose
19	-	2	35-31135	78" x 1/2" -8JIC/-8JIC Hose W/Cordura
20	2	2	35-31136	81" x 1/2" -8JIC/-8JIC Hose W/Cordura
21	2	2	57-20740	1/4" Flat Washer
22	2	2	57-20744	1/2" Washer

Hose Not Drawn to Scale

Item A for CNH, JD 9R, JD 9030

Item B for Versatile, Challenger MT900 and JD 9RX

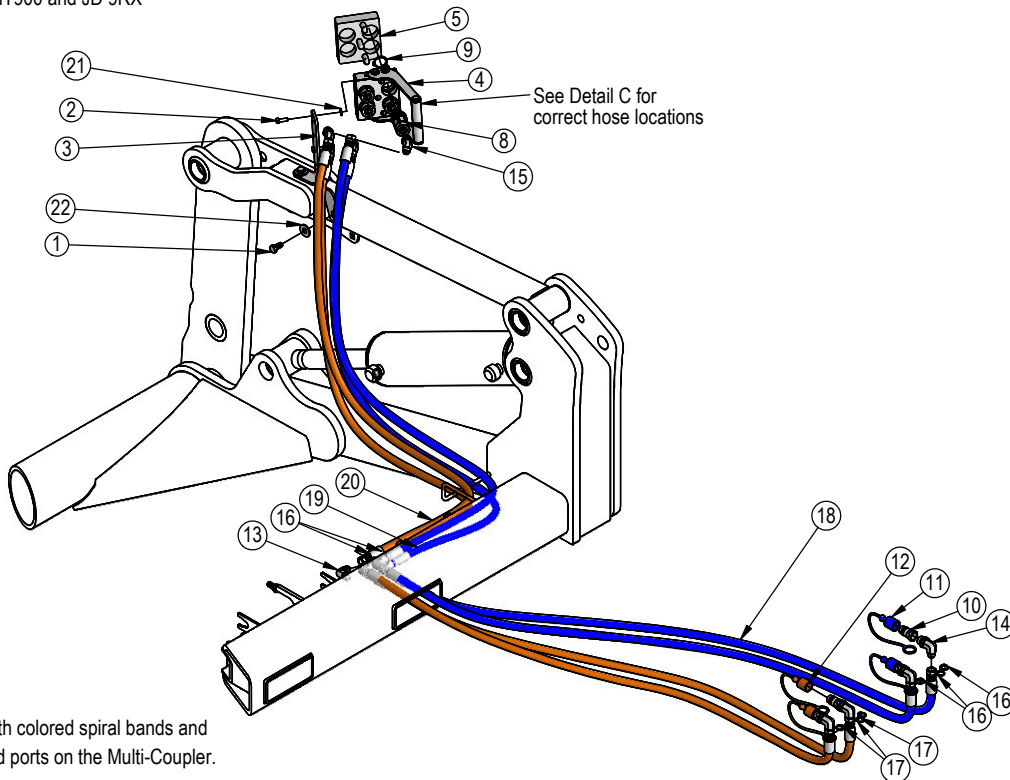

NOTE: All hoses are marked with colored spiral bands and should be attached to designated ports on the Multi-Coupler.

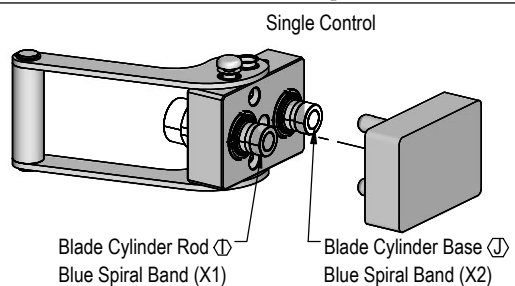
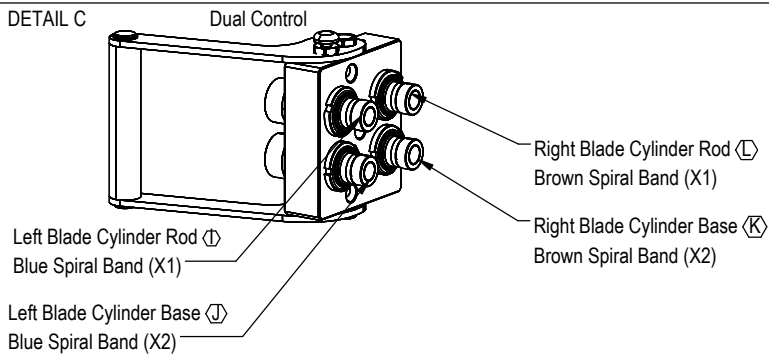

ITEM NO.	PART NO.	HANT QTY.	NAHT QTY.	DESCRIPTION
1	16-812525	2	2	8mm x 1.25mm x 25mm Metric Hex Bolt Gr 10.9
2	25-19868	1	1	Multi-Coupling Plate - 2 Port - Fixed
3	25-19871	1	1	Multi-Coupling Plate - 2 Port - Cap
4	57-20740	2	2	1/4" Flat Washer

HANT

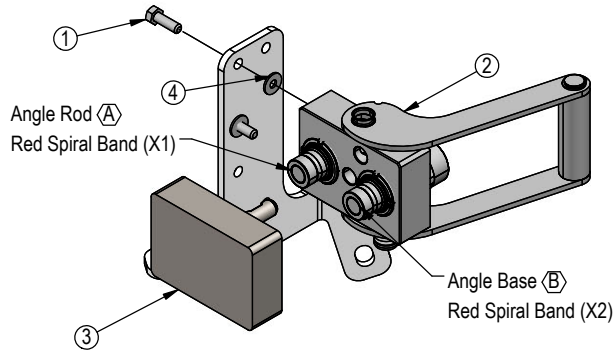

NAHT

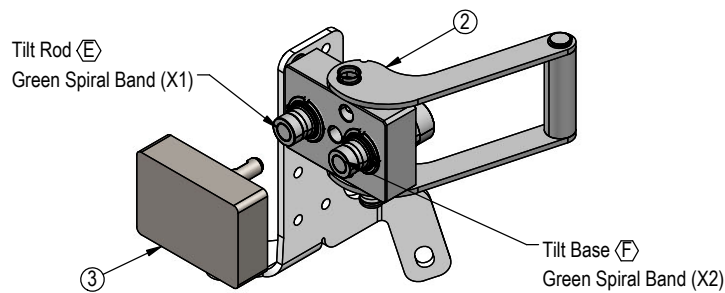

Note: Refer to Pages 6-8 for the correct hose lengths and hose location.

Note: All connections are identified by spiral bands. 2 bands are from the base end of a cylinder and 1 band is from the rod end of a cylinder. Orange = Lift, Green = Tilt, Red = Angle, Blue = Left Blade Cylinder, and Brown = Right Blade Cylinder.

1. Connect the lift hoses to the lift cylinders.
2. Verify that hoses are not twisted and protected from rubbing on any sharp edges. See Pages 6-8 for proper hose routing.
3. Attach the multi-coupler to the top arm mount and install the 45° fittings.
4. Identify each remaining hose at the front of the undercarriage by the colored bands on end of hose and connect hose to corresponding 45° fitting on multi-coupler. Refer to Pages 6-8 for proper hose locations.
5. Hoses were plugged into the rear of the tractor during the undercarriage installation.
6. Continue on Page 10 for initial startup instructions.

Prior to operating the blade system, all air must be purged from the hydraulic system. Follow the steps below for each function on your blade.

Lift Function:

1. With the lift frame down and blocked, loosen the fittings on both ends of the lift cylinders.
2. Actuate the raise function to supply oil to the rod end of the cylinders.
3. When oil starts to flow from the fittings, stop oil flow, and tighten the fitting on the rod end of the lift cylinders.
4. Continue to flow oil until the system is fully raised and then block the lift frame.
5. Actuate the function in the opposite direction to supply oil to the base end of the lift cylinders.
6. When all air is removed from the lift system, stop oil flow and tighten the fittings on the base end of the lift cylinders.
7. Raise lift system and remove blocks. Cycle up and down 5 more times.
8. Check tractor oil level and fill if necessary.
9. Continue with connecting the blade on Page 11.

Tilt Function:

1. Use a lift or jack to tilt the blade system until the left side is fully up, loosen the fittings on the rod and base end of both tilt cylinders.
2. Actuate the tilt function to extend the right tilt cylinder and supply oil to the base end of the right cylinder and to the rod end of the left cylinder.
3. When oil starts to flow from the fittings, stop oil flow, and tighten the fitting on the base end of the right cylinder and rod end of the left cylinder.
4. Remove the lift or jack.
5. Continue to actuate the tilt function until oil flows out of the remaining open ports.
6. Actuate the tilt function in the opposite direction.
7. When all air is removed from the tilt system, stop oil flow, and tighten the remaining fittings on the cylinders.
8. Cycle both cylinders in and out 5 more times.
9. Check tractor oil level and fill if necessary.

Angle Function:

1. Loosen the fittings on the rod and base end of the left angle cylinder.
2. Actuate the angle function to extend the left angle cylinder and supply oil to the base end of the left cylinder.
3. When oil starts to flow from the fittings, stop oil flow, and tighten the fitting on the base end of the left cylinder.
4. Continue to actuate the left angle function in the same direction until the cylinder is fully extended.
5. Actuate the left angle function in the opposite direction.
6. When oil starts to flow from the rod end fitting, stop oil flow, and tighten the rod end fitting on the left angle cylinder.
7. Continue to actuate the left angle function until cylinder is fully retracted.
8. Loosen the fittings on the rod and base end of the right angle cylinder.
9. Actuate the angle function to extend the right angle cylinder and supply oil to the base end of the right cylinder.
10. When oil starts to flow from the fittings, stop oil flow, and tighten the fitting on the base end of the right cylinder.
11. Continue to actuate the right angle function in the same direction until the cylinder is fully extended.
12. Actuate the right angle function in the opposite direction.
13. When oil starts to flow from the rod end fitting, stop oil flow, and tighten the rod end fitting on the right angle cylinder.
14. Continue to actuate the right angle function until cylinder is fully retracted.
16. Cycle the left cylinder in and out 5 more times and then the right cylinder in and out 5 more times.
16. Check tractor oil level and fill if necessary.

Blade Width Function:

1. Loosen the fittings on the rod and base end of the right cylinder.
2. Actuate the blade width function to extend the right cylinder and supply oil to the base end of the right cylinder.
3. When oil starts to flow from the fittings, stop oil flow, and tighten the fitting on the base end of the right cylinder.
4. Fully extend the right cylinder.
5. Actuate the function in the opposite direction.
6. When oil starts to flow from the rod end fitting, stop oil flow, and tighten the remaining fittings on the cylinders.
7. Continue to actuate the cylinder until cylinder is fully retracted.
8. Cycle the right cylinder in and out 5 more times.
9. Repeat Steps 1-8 for the left cylinder
10. Check tractor oil level and fill if necessary.

Run the blade through all the functions. If any function does not operate correctly, refer to corresponding section above and re-bleed. If problem still persists, call Grouser Products.

To Connect:

Note: If necessary, use a spotter to help center the blade on the lift system.

1. If necessary, lift the locking latch and push the quick attach lock handle on the left side of the lift system to open the quick attach system. Refer to Page #16-17 for further clarification on the quick attach system.
2. Drive the tractor forward slowly until the top edge of the male quick attach is under the top hook of the female quick attach on the blade assembly.
3. Raise the lift system until the male quick attach engages the female hook. If both sides don't fully engage, reposition. Continue to raise the lift system until the blade is off the ground and the female quick attaches are against the front of the male quick attaches.
4. Shut off the tractor engine and set the parking brake.
5. Pull the quick attach lock handle to engage the quick attach pins and lift the locking latch to lock the handle in place.
6. Clean and connect hydraulic multi-coupler on the top arm. Refer to Pages 31-32 for cleaning and connecting information.
7. If initial startup, refer to Page 10 before operating any function of the blade.

To Disconnect:

1. Lower the blade until the cutting edge is off the ground a few inches.
2. Shut off the tractor engine and set the parking brake.
3. Unhook the multi-coupler on the top arm.
4. Remove the multi-coupler covers from the parking stations on the blade assembly and install on the multi-couplers on the top arms.
5. Plug the blade side multi-couplers into the parking station.
6. Lift the locking latch and push the quick attach lock handle to disengage the quick attach pins.
7. Start tractor, disengage the parking brake, and lower the blade until cutting edge is on the ground.
8. Continue to slowly lower the lift system to disengage the blade.
9. Slowly back away from the blade. When lift system is clear from the blade, raise the lift system.
10. Shut off the tractor engine and set the parking brake.

THE INFORMATION CONTAINED IN THIS DRAWING IS THE SOLE PROPERTY OF GROUSER PRODUCTS INC. ANY REPRODUCTION IN PART OR WHOLE WITHOUT THE WRITTEN PERMISSION OF GROUSER PRODUCTS INC. IS PROHIBITED.

Instructions:

1. Remove the male quick coupler from the SCV - UP which should be from the Rod End of the Lift Cylinder.
2. Remove the hose from the 90° fitting installed into the male quick coupler removed in Step #1.
3. Install the -12 male pipe x -12 female JIC Swivel fitting into the end of the control valve on the side the arrow is pointing to. Use pipe thread sealant on pipe fittings.
4. Attach the 90° fitting with the male quick coupler still attached to the JIC Swivel fitting that was installed in Step #3.
5. Install the -12 male pipe x -12 male JIC Straight fitting into the end of the control valve on the side opposite that the arrow is pointing to. Use pipe thread sealant on pipe fittings.
6. Attach the end of the original hose to the fitting attached in Step #5. See diagram below for further clarification on orientation of the control valve.
7. Plug male quick coupler back into the tractor
8. To adjust the control valve, unscrew the adjusting knob at the top of the valve. Run the the lift cylinders up and down.
9. Adjust the lift speed by turning the adjusting knob back in with 1/2 turn increments.
10. After each 1/2 turn, run the lift cylinders up and down. Continue to do this until the desired speed is achieved and there is no chatter or cavitation.
11. After the control valve is adjusted, lock the adjusting knob with the lock screw.

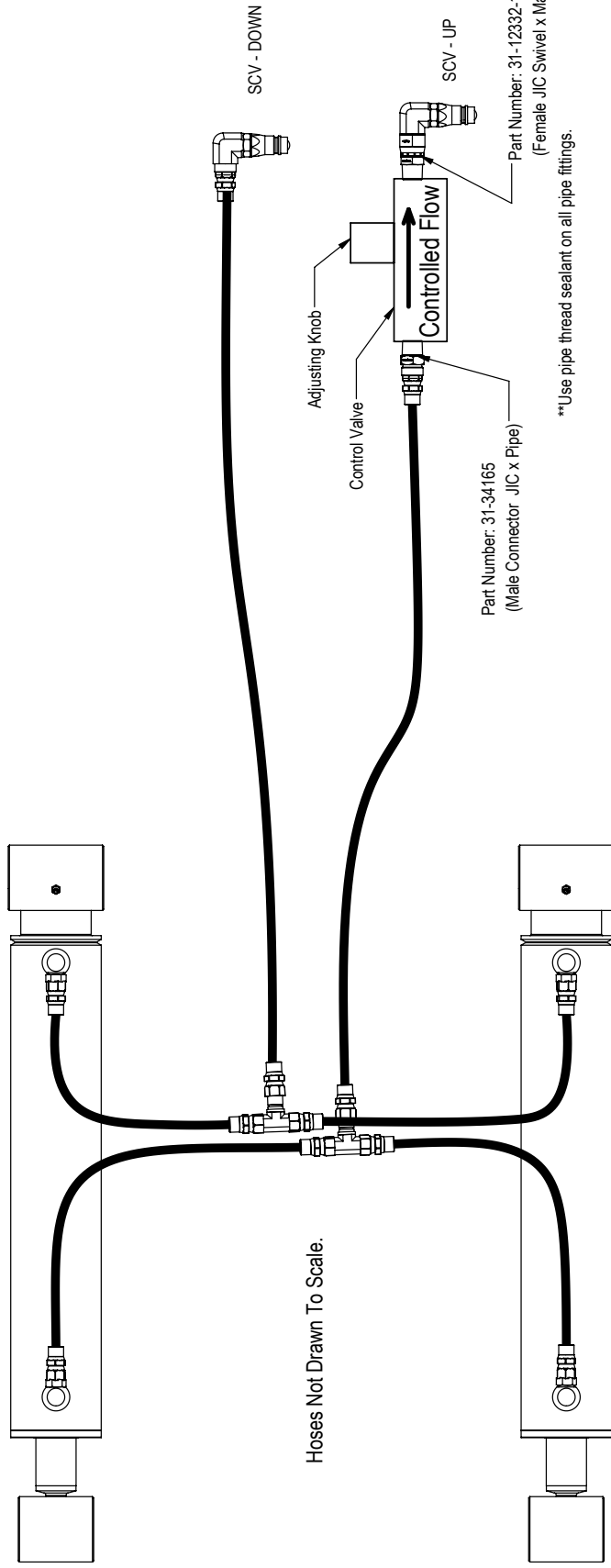

Hoses Not Drawn To Scale.

GROUSER PRODUCTS INC.
 755 2nd Ave NW Phone 701.282.7710
 West Fargo, ND 58078 Fax 701.282.8131
 WWW.GROUSER.COM

TITLE: Lift System Speed Control Kit	
Date: 8/24/2016	DWG. NO.: 19699-INS

Note:
 Your system may look slightly different from the diagram shown above but all lift systems are plumbed so that the rod end of both cylinders come to a t-fitting and then run to the back of the tractor and hook up to the SCV - UP.
 The base end of both cylinders come to a t-fitting and then run to the back of the tractor and hook up to the SCV - DOWN.

Skid Shoe Adjustment:

1. Remove the handle from the ratchet keeper by pulling the hitch clip pin and insert it into the handle receiver on the ratchet jack.
2. Loosen the locking nut on the ratchet jack.
3. Hold the body of the ratchet jack and rotate the ratchet jack handle to raise or lower the skid shoes.
4. If the skid shoe is not moving in the proper direction, flip the forward/reverse lever on the handle (see Figure 2). Rotate the ratchet jack handle again to move the skid shoe in the desired direction.
5. After the skid shoe is adjusted, rotate the ratchet jack handle until it rests against the ratchet keeper. Return the removable handle to the ratchet keeper ensuring that the ratchet jack handle is captured by the removable handle and the ratchet keeper. Secure the handle to the ratchet keeper with the hitch clip pin.
6. Tighten the locking nut against the ratchet jack body to keep it from moving.
7. When skid shoes are worn up to the bolt heads, replace skid shoes.

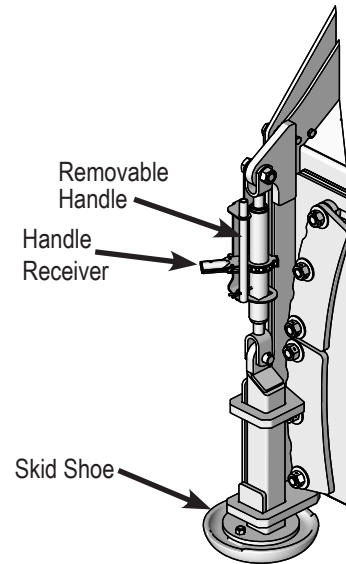

Figure 1

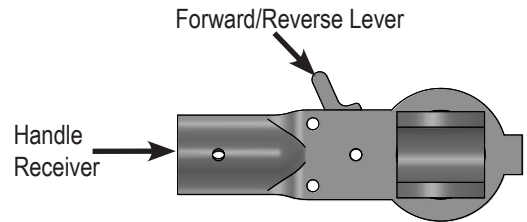

Figure 2

Preferred Method:

1. The preferred blade position for adjusting the tilt plates is laying face down on blocks.
2. Remove the 6 nuts from the right tilt plates.
3. Remove skid mount to obtain better access to the bottom nuts.
4. Add or remove washers as needed to adjust tilt-way clearance to 1/16" - 1/8".
5. Reinstall the nuts in the right tilt plates.
6. Follow Steps #2-5 for the left tilt plates.
7. Once the tilt-way clearance is set, torque bolts to 640 ft-lbs.

Non-Preferred Method:

Note: Do not remove all of the bolts at the same time if the blade is not laying face down.

1. The non-preferred blade position for adjusting the tilt plates is the blade in the upright position.
2. Remove the skid shoe mounts to obtain better access to bottom tilt plate nuts.
3. Remove the 3 nuts from the top right tilt plate and the bottom left tilt plate..
4. Add or remove washers as needed to adjust tilt-way clearance to 1/16" - 1/8".
5. Reinstall the nuts in the top right tilt plate and the bottom left tilt plate.
6. Follow Steps #2-5 for the bottom right tilt plate and the top left tilt plate.
7. Once the tilt-way clearance is set, torque bolts to 640 ft-lbs.

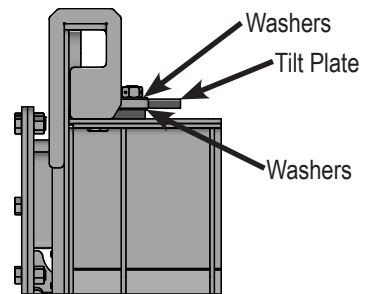

ITEM NO.	PART NO.	Qty.	DESCRIPTION
1	15-18735	1	XAXT Blade Weld
2	15-18760-L	1	3-5 Slider End Weld - Left
3	15-18760-R	1	3-5 Slider End Weld - Right
4	16-16305	12	3/8" x 1.25" Flanged Elevator Bolt
5	16-18945	2	1" x 3" Hex Bolt Gr 5 NC - Short Thread
6	16-20517	4	3/4" X 4-1/2" Hex Bolt Gr 8 NC YZ
7	16-20538	18	7/8" X 2" Hex Bolt Gr 8 NC YZ
8	16-20558	3	1" X 2" Hex Bolt Gr 8 NC YZ
9	16-20562	4	1" X 3" Hex Bolt Gr 8 NC YZ
10	16-20563	8	1" X 3-1/4" Hex Bolt Gr 8 NC YZ
11	16-21064	4	3/8" x 1" Carriage Bolt Gr 5 NC CZ
12	16-21666	4	5/8" X 1-3/4" Plow Bolt Gr 5 NC (#3 Flat Head)
13	16-21748	38	3/4" X 2" Plow Bolt Gr 8 NC

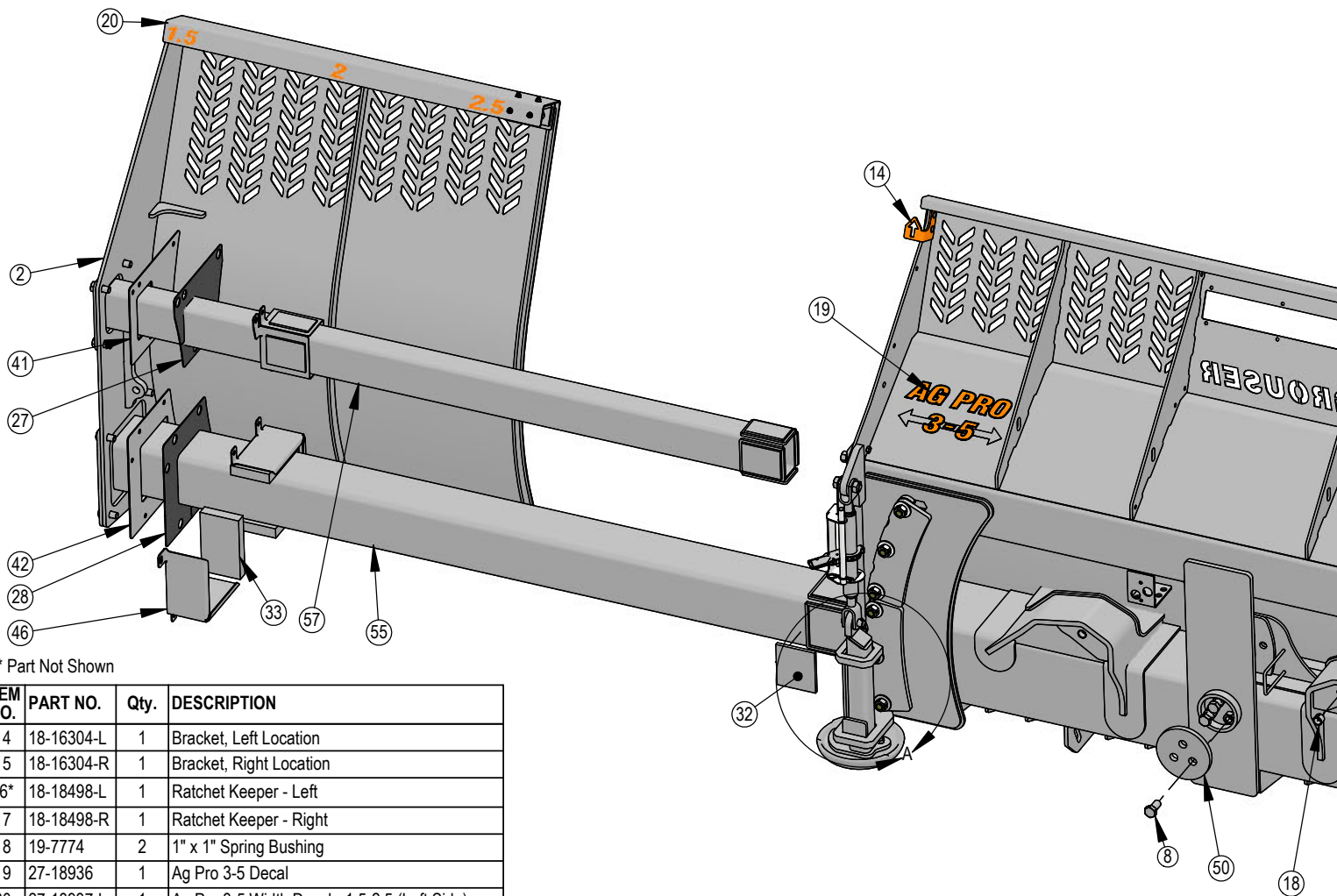

* Part Not Shown

ITEM NO.	PART NO.	Qty.	DESCRIPTION
14	18-16304-L	1	Bracket, Left Location
15	18-16304-R	1	Bracket, Right Location
16*	18-18498-L	1	Ratchet Keeper - Left
17	18-18498-R	1	Ratchet Keeper - Right
18	19-7774	2	1" x 1" Spring Bushing
19	27-18936	1	Ag Pro 3-5 Decal
20	27-18937-L	1	Ag Pro 3-5 Width Decal - 1.5-2.5 (Left Side)
21	27-18937-R	1	Ag Pro 3-5 Width Decal - 2.5-1.5 (Right Side)
22	27-40917	2	Ratchet Holder Storage Decal
23	29-11118-4	1	4' - 3/4" x 8" Cutting Edge
24*	29-11118-5	1	5' - 3/4" x 8" Cutting Edge
25	29-18777	2	58" - 3/4" x 8" Cutting Edge
26	34-16158	6	Bearing, 2.625 x 6.00 W/Holes
27	34-16419	2	Top Seal
28	34-16420	1	8" Tube Seal
29	34-16421	1	10" Tube Seal
30	34-16425	8	Top Narrow UHMW
31	34-16426	8	Top Wide UHMW
32	34-16427	4	8" Inner UHMW
33	34-16428	4	8" Outer UHMW
34	34-16429	8	10" UHMW

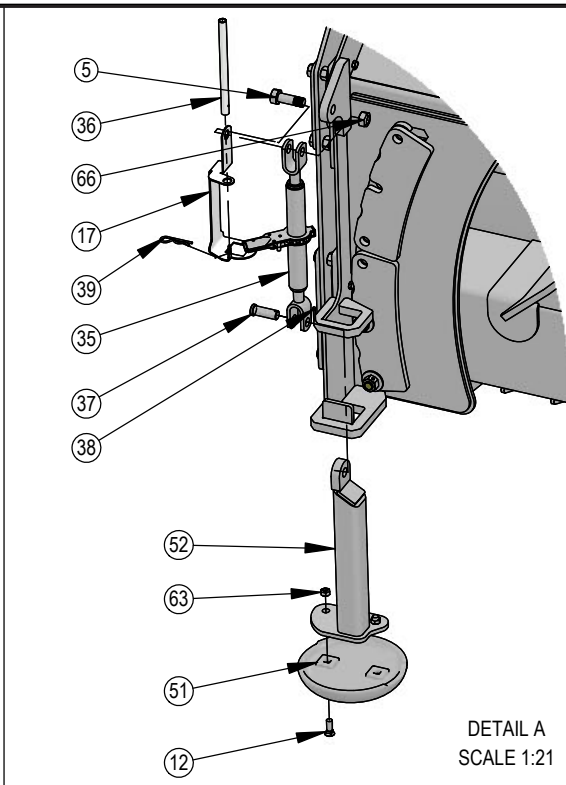

DETAIL A
SCALE 1:21

ITEM NO.	PART NO.	Qty.	DESCRIPTION
35	34-17565	2	Ratchet Jack
36	34-17567	2	Handle, Ratchet Jack
37	43-18463	2	1" x 2.75" Pin
38	43-18943	2	3/16" x 1-1/2" Cotter Pin
39	43-7767	2	Cylinder Pin Clip
40	44-16401	1	Plate, Top Cover Right
41	44-16402	1	Plate, Top Cover Left
42	44-16403	1	Plate, 8" Cover
43	44-16404	1	Plate, 10" Cover
44	44-16417	2	Plate, Slider
45	44-16422	4	Top Outer Retainer
46	44-16423	2	8" Outer Retainer
47	44-16424	2	10" Outer Retainer
48	44-16525	2	Standoff
49	44-16977	6	Plate, Slider Standoff Shim
50	44-3749	1	Backdrag Brace Plate
51	50-15458	2	12" Round Mushroom Skid Shoe
52	50-43715	1	Slider Skid Shoe Weld (Left)
53*	50-43720	1	Slider Skid Shoe Weld (Right)
54	52-18299	4	Tilt Plate
55	53-18768	1	8 x 8 Tube Weld, 3-5 Slider
56	53-18770	1	10 x 10 Tube Weld, 3-5 Slider
57	53-18772	2	4 x 6 Tube Weld, 3-5 Slider
58	57-20749	24	1" Flat Washer CZ
59	70-20584	22	1/2" Hex Nut Gr 5 NC CZ
60	70-20598	18	7/8" Hex Nut Gr 8 NC CZ
61	70-20609	12	1" Hex Center Lock Nut Gr 5 NC CZ
62	70-20622	16	3/8" Flange Hex Nut Gr 5 NC CZ
63	70-20646	4	5/8" Hex Top Lock Nut Gr 5 NC CZ
64	70-20647	38	3/4" Hex Top Lock Nut Gr 5 NC CZ
65	70-20804	22	1/2" Hex Jam Nut NC CZ
66	70-20999	2	1" Hex Top Lock Nut Gr 8 NC YZ

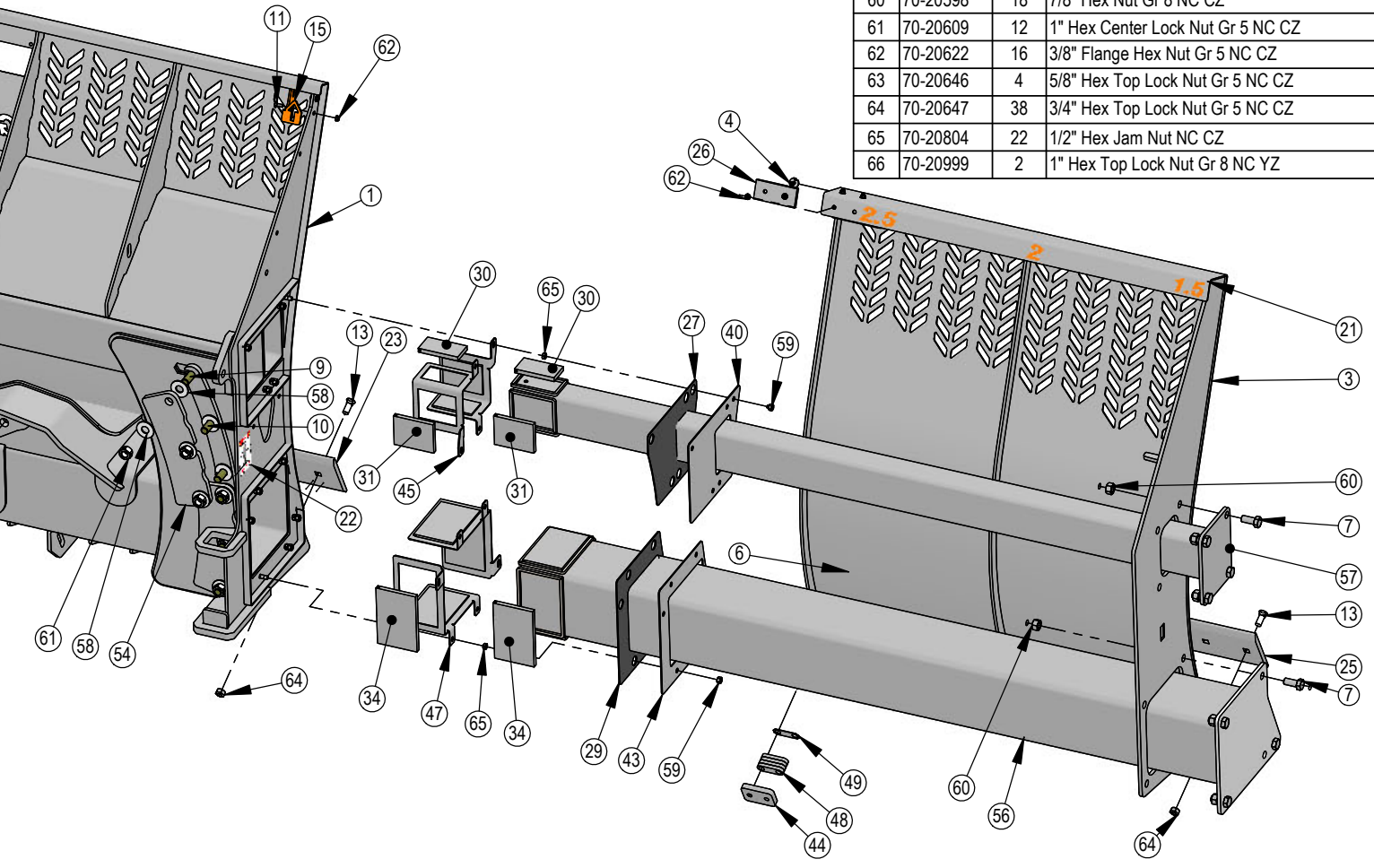

DWG. NO.: 18735-A

Hydraulic Angle-Hydraulic Tilt and Hydraulic Angle-No Tilt System

ITEM NO.	QTY.	PART NO.	DESCRIPTION
1	1	16-20011	1/4" x 2-3/4" Hex Bolt Gr 5 NC
2	2	16-20130	1/2" x 2-1/2" Hex Bolt Gr 5 NC
3	1	16-20560	1" x 2-1/2" Hex Bolt Gr 8 NC
4	2	16-21065	3/8" x 1-1/4" Carriage Bolt Gr 5 NC
5	4	16-21126	1/2" x 1-1/2" Carriage Bolt Gr 5 NC
6	2	19-40440	.378" ID x .503" OD x .375" Spacer
7	2	27-2409	Pinch Decal (Hand)
8	2	27-9503	Pinch Decal (Foot)
9	2	19-7774	1" x 1" Spring Bushing
10	1	32-19130	Angle Frame
11	1	32-19240	Tilt Frame Weld
12	1	34-17799	Latch Spring
13	1	39-14663	Latch
14	1	39-14665	Handle Weld
15	1	39-3072	Rubber Handle
16	2	43-18486	Ag Pro SS QA Lock Pin
17	1	43-19245	Angle Pin Weld

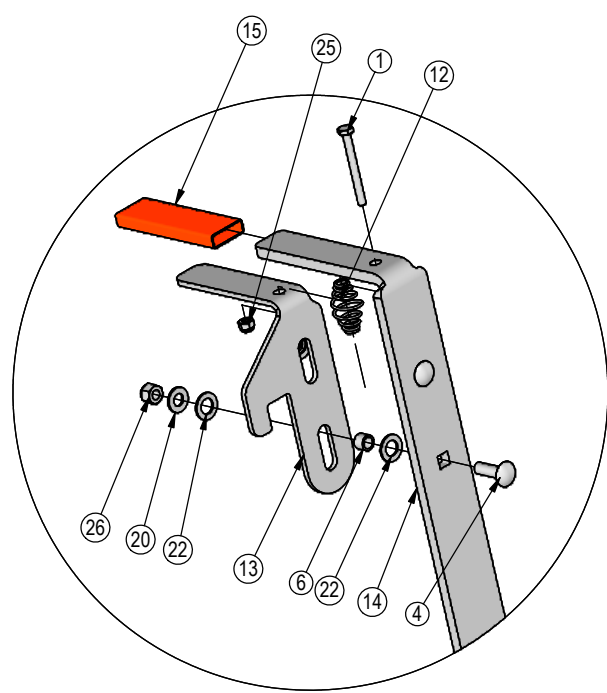
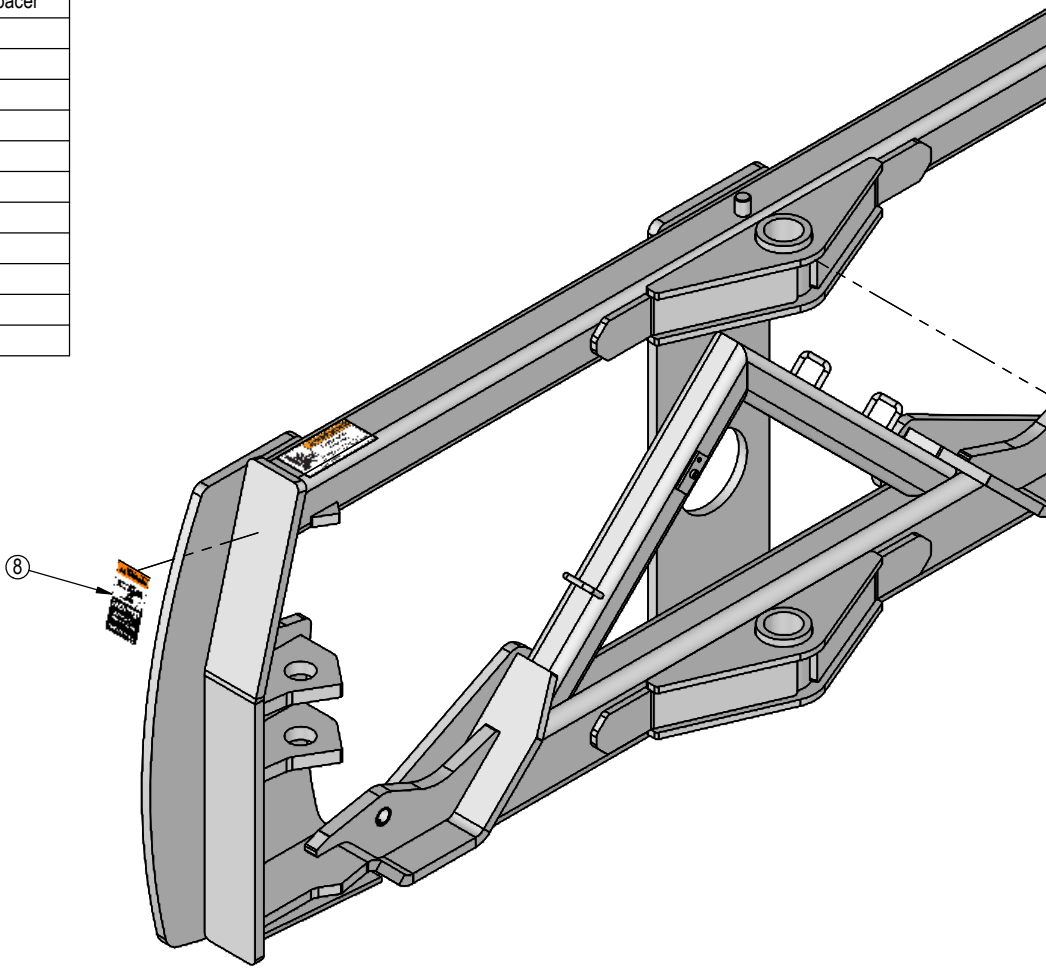

ITEM NO.	QTY.	PART NO.	DESCRIPTION
18	4	44-8490	Spacer
19	1	57-16928	Plate, Washer
20	2	57-20742	3/8" Flat Washer
21	4	57-20744	1/2" Washer
22	4	57-40408	3/8" Flat Nylon Washer
23	6	70-20604	1/2" Center Lock Hex Nut
24	2	70-20607	3/4" Center Lock Hex Nut Gr 2 NC
25	1	70-20610	1/4" Nyloc Hex Nut Gr 5 NC
26	2	70-20612	3/8" Nyloc Hex Nut Gr 5 NC
27	1	75-18480	Bell Crank Weld
28	1	75-18485	Link, Right Pin
29	1	75-18526	Link, Handle To Left Pin
30	1	75-18527	Link, Left Pin

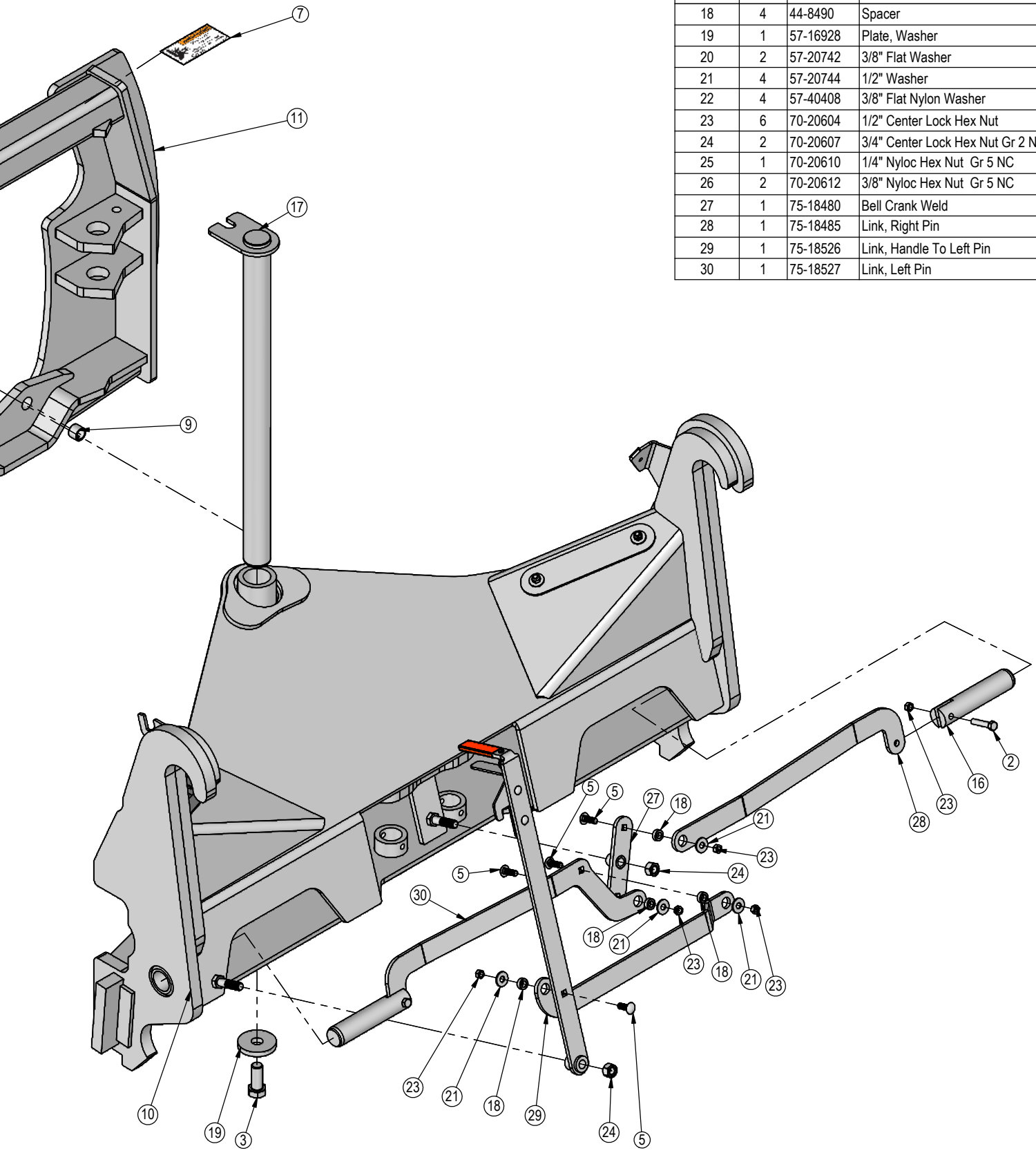

DWG. NO.: 19885

Hydraulic Angle-Hydraulic Tilt Hydraulics

ITEM NO.	QTY.	PART NO.	DESCRIPTION
1	3	16-20038	5/16" x 2" Hex Bolt Gr 5 NC
2	2	16-20040	5/16" x 2-1/2" Hex Bolt Gr 5 NC
3	2	16-20134	1/2" x 3-1/2" Hex Bolt Gr 5 NC
4	2	16-20219	3/4" x 2-1/4" Hex Bolt Gr 5 NC
5	4	16-35C612	3/8" x 3/4" Flange Bolt
6	3	18-19311-03-P-087	Hose Clamp
7	1	18-19311-03-P-100	Hose Clamp
8	3	18-19312-03	Twin Cover Plate
9	1	18-19313-04	Twin Stacking Bolt
10	1	18-19314-02	Twin Safety Plate
11	1	18-19315-L	Hose Guide Weld
12	2	19-13515	Spacer, NR Pin
13	4	19-13577	NR Pin Spacer Clevis End
14	8	19-16695	2.25" x 2.00" x 1.50" Spring Bushing
15	4	25-19865	Multi-Coupling - Female Coupler
16	1	25-19866	Multi-Coupling Plate - 4 Port Mobile
17	4	25-40407	Multi-Coupling - Snap Ring
18	2	26-34747	4 x 8 Cylinder w/ Clevis Ends
19	2	26-34750	5 x 20 Cylinder Bushed Tube Ends
20	6	31-11492-8-8	Male JIC x Female JIC Swivel Nut Elbow 45°
21	2	31-11699-10-8	JIC Union
22	2	31-13933-2-2	1/8" NPT Street Elbow
23	2	31-34030	Bulkhead Run Tee JIC
24	2	31-34040	Straight JIC x O-Ring
25	2	31-34041	Straight JIC x O-Ring
26	2	31-34042	Straight JIC x O-Ring
27	4	31-34050	Straight Thread Elbow 90° JIC x O-Ring
28	2	31-34060	Branch Tee JIC x O-Ring
29	4	31-34150	Straight Thread Elbow 45° JIC x O-Ring

Note: Every hydraulic function from the front to the back of the system is designated by a letter and can also be referenced on the Hydraulic Schematic.

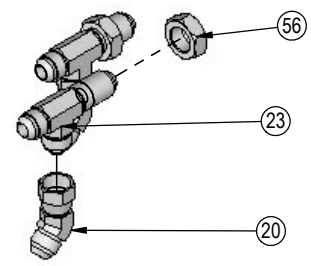
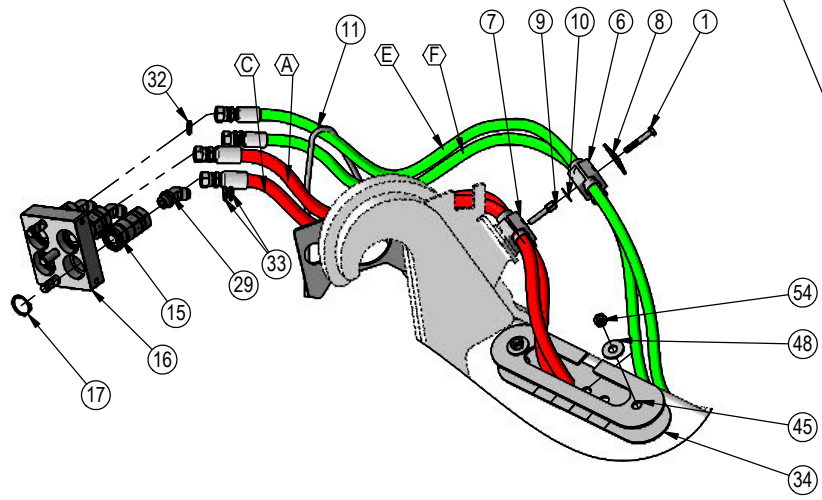
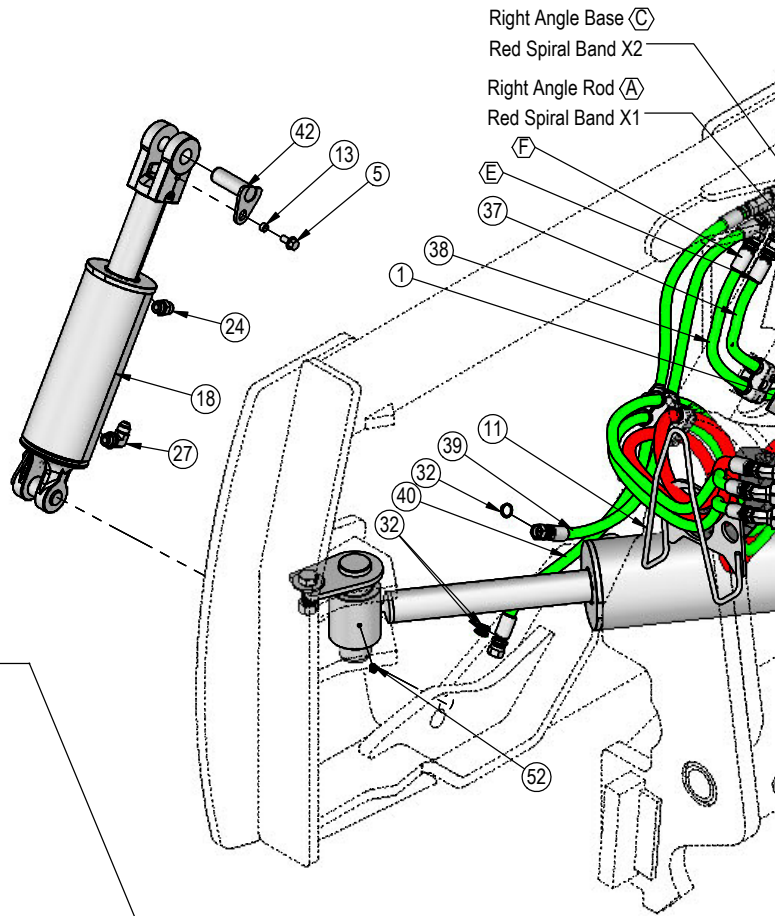
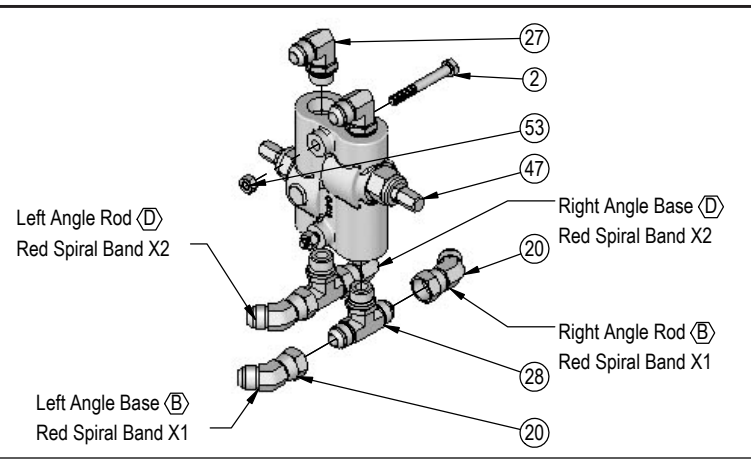

Note: The cylinder part number is stamped on the base end of the cylinder opposite of the hydraulic ports.

Cylinder	Part No.	Description
26-34747	49-12271	Seal Kit 4x8 Nitrided Rod, Clevis Ends
26-34750	49-12275	Seal Kit 5 x 20 Nitrided Rod

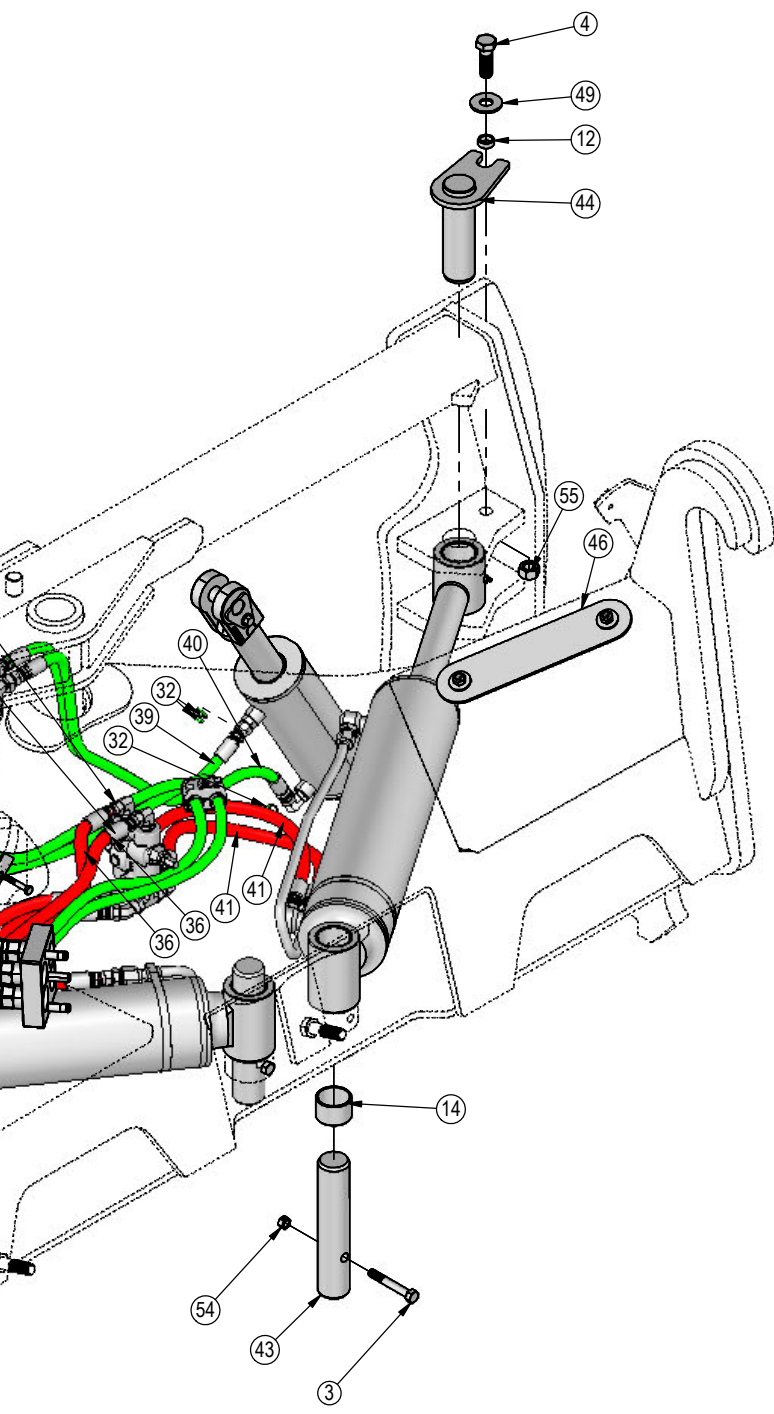

ITEM NO.	QTY.	PART NO.	DESCRIPTION
30	2	34-12932	Cylinder Saddle
31	2	34-12933	Hose Clamp (worm drive - 5.0)
32	18	34-18888-GR	-12 Green - Spiral Band
33	18	34-18888-RD	-12 Red - Spiral Band
34	1	34-19217	Rubber Seal
35	2	35-12931	Formed Steel Line
36	2	35-19355	75.5" x 1/2" -8JIC/-8JIC Hose (w/ 1 Collar & Cordura)
37	1	35-19356	122" x 3/8" -8JIC/-8JIC Hose (w/ 3 Collar & Cordura)
38	1	35-19359	128.5" x 3/8" -8JIC/-8JIC Hose (w/3 Collar & Cordura)
39	2	35-30018	33" x 3/8" -8JIC/-8JIC Hose
40	2	35-30081	37" x 3/8" -8JIC/-8JIC Hose
41	4	35-31113	28" x 1/2" -8 JIC/-8 JIC Hose w/ Cordura
42	4	43-13580	Pin Weld
43	2	43-18487	Angle Cylinder Base Pin
44	2	43-18490	Angle Cylinder Rod Pin Weld
45	1	44-19218	Seal Clamp Plate
46	1	44-19219	Cover Plate
47	1	56-7772	Valve
48	4	57-20744	1/2" Washer
49	2	57-20747	3/4" Flat Washer
50	2	58-18994-0440	44" Grease Hose (w/lock nut and grease zerk)
51	2	58-18994-0570	57" Grease Hose (w/lock nut and grease zerk)
52	2	58-9369	Straight 1/8" NPT Grease Zerk
53	2	70-20581	5/16" Hex Nut Gr 5 NC
54	6	70-20604	1/2" Center Lock Hex Nut
55	2	70-20607	3/4" Center Lock Hex Nut Gr 2 NC
56	2	70-20807	3/4" Hex Jam Nut NF

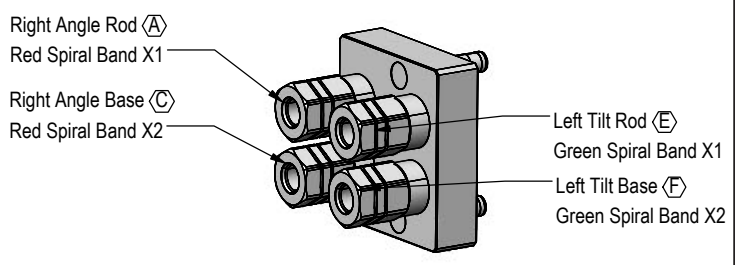
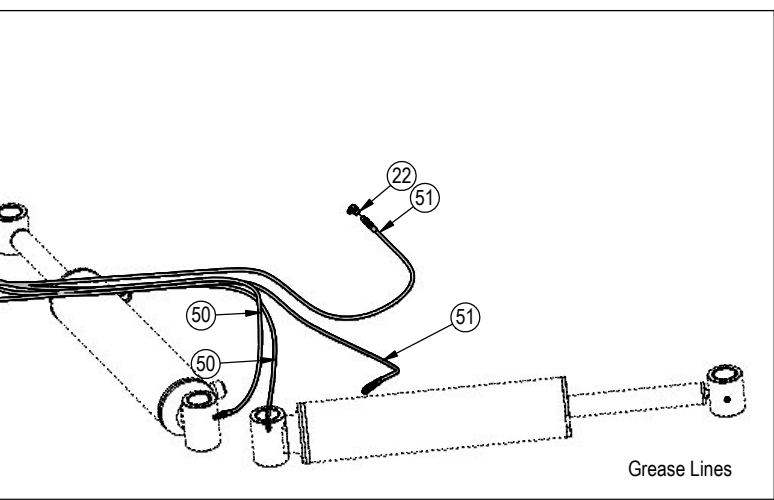
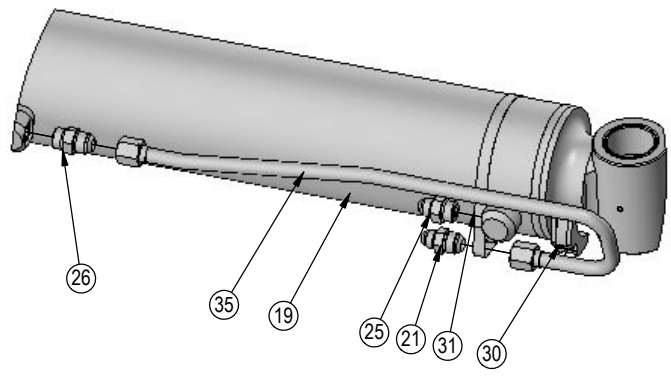

Note: View is from Multi-Coupler Installed on Top Arm.
All hoses are marked with colored spiral bands and should be attached to designated ports on the Multi-Coupler.

DWG. NO.: 19885

Hydraulic Angle-No Tilt Hydraulics

ITEM NO.	QTY.	PART NO.	DESCRIPTION
1	1	14-9366	Ag Pro Non Tilt Bar
2	1	16-20038	5/16" x 2" Hex Bolt Gr 5 NC
3	2	16-20040	5/16" x 2-1/2" Hex Bolt Gr 5 NC
4	2	16-20134	1/2" x 3-1/2" Hex Bolt Gr 5 NC
5	2	16-20219	3/4" x 2-1/4" Hex Bolt Gr 5 NC
6	2	16-20564	1" x 3-1/2" Hex Bolt Gr.8 NC
7	1	18-19311-03-P-100	Hose Clamp
8	1	18-19312-03	Twin Cover Plate
9	1	18-19315-L	Hose Guide Weld
10	2	19-13515	Spacer, NR Pin
11	8	19-16695	2.25" x 2.00" x 1.50" Spring Bushing
12	2	19-7774	1" x 1" Spring Bushing
13	2	25-19865	Multi-Coupling - Female Coupler
14	1	25-19869	Multi-Coupling Plate - 2 Port - Mobile
15	2	25-40407	Multi-Coupling - Snap Ring
16	2	26-34750	5 x 20 Cylinder Bushed Tube Ends
17	4	31-11492-8-8	Male JIC x Female JIC Swivel Nut Elbow 45°
18	2	31-11699-10-8	JIC Union
19	2	31-13933-2-2	1/8" NPT Street Elbow
20	2	31-34041	Straight JIC x O-Ring
21	2	31-34042	Straight JIC x O-Ring
22	2	31-34050	Straight Thread Elbow 90° JIC x O-Ring
23	2	31-34060	Branch Tee JIC x O-Ring
24	2	31-34150	Straight Thread Elbow 45° JIC x O-Ring
25	2	34-12932	Cylinder Saddle
26	2	34-12933	Hose Clamp (worm drive - 5.0)
27	18	34-18888-RD	-12 Red - Spiral Band
28	1	34-19217	Rubber Seal
29	2	35-12931	Formed Steel Line
30	2	35-19355	75.5" x 1/2" -8JIC/-8JIC Hose (w/ 1 Collar & Cordura)
31	4	35-31113	28" x 1/2" -8 JIC/-8 JIC Hose w/ Cordura
32	2	43-18487	Angle Cylinder Base Pin
33	2	43-18490	Angle Cylinder Rod Pin Weld
34	1	44-19218	Seal Clamp Plate
35	1	44-19219	Cover Plate
36	1	56-7772	Valve
37	4	57-20744	1/2" Washer

Note: Every hydraulic function from the front to the back of the system is designated by a letter and can also be referenced on the Hydraulic Schematic.

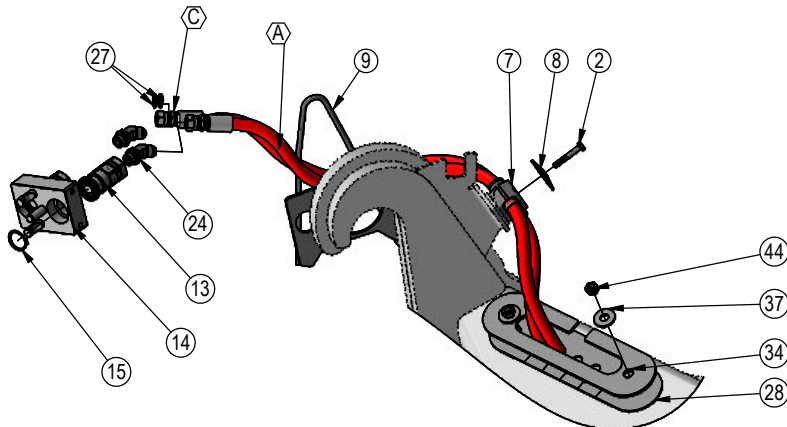
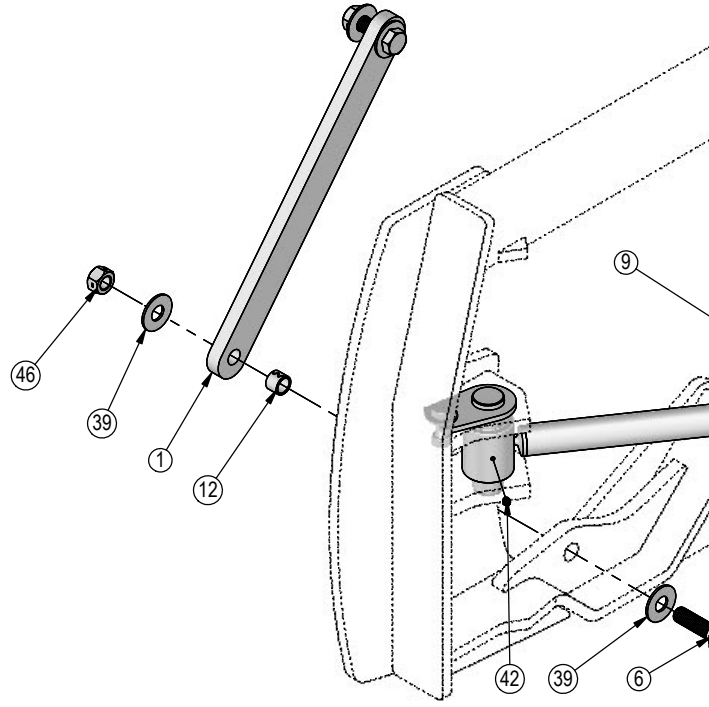
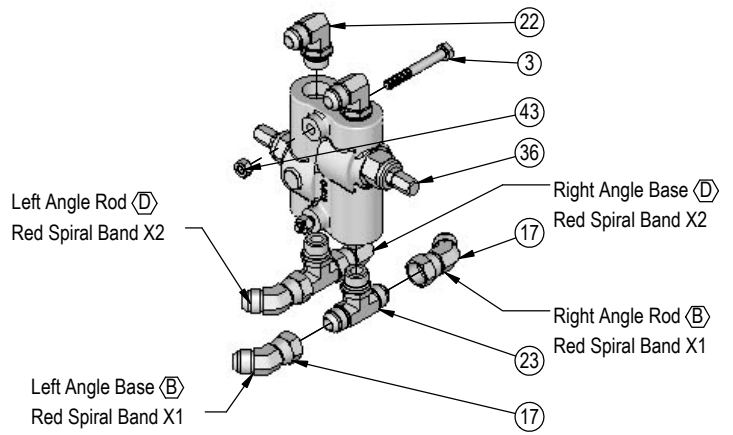

Note: The cylinder part number is stamped on the base end of the cylinder opposite of the hydraulic ports.

Cylinder	Part No.	Description
26-34750	49-12275	Seal Kit 5 x 20 Nitrided Rod

ITEM NO.	QTY.	PART NO.	DESCRIPTION
38	2	57-20747	3/4" Flat Washer
39	4	57-20749	1" Flat Washer
40	2	58-18994-0440	44" Grease Hose (w/lock nut and grease zerk)
41	2	58-18994-0570	57" Grease Hose (w/lock nut and grease zerk)
42	2	58-9369	Straight 1/8" NPT Grease Zerk
43	2	70-20581	5/16" Hex Nut Gr 5 NC
44	6	70-20604	1/2" Center Lock Hex Nut
45	2	70-20607	3/4" Center Lock Hex Nut Gr 2 NC
46	2	70-20609	1" Hex Center Lock Nut Gr.2 NC

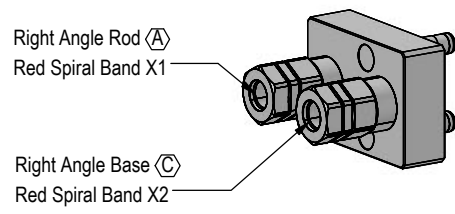
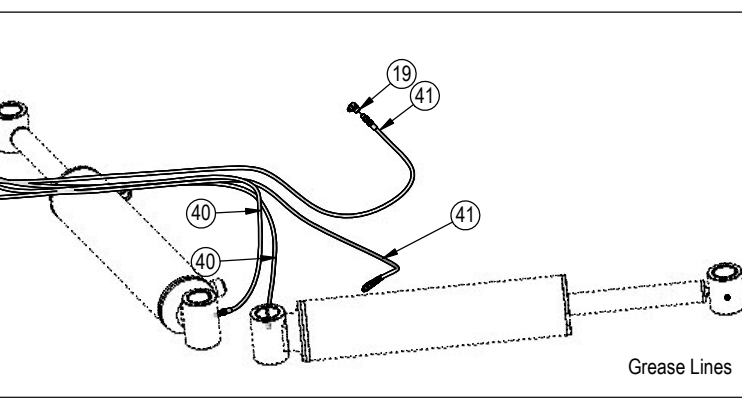
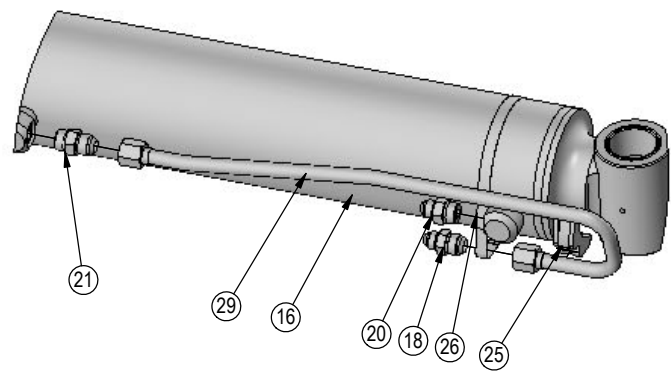
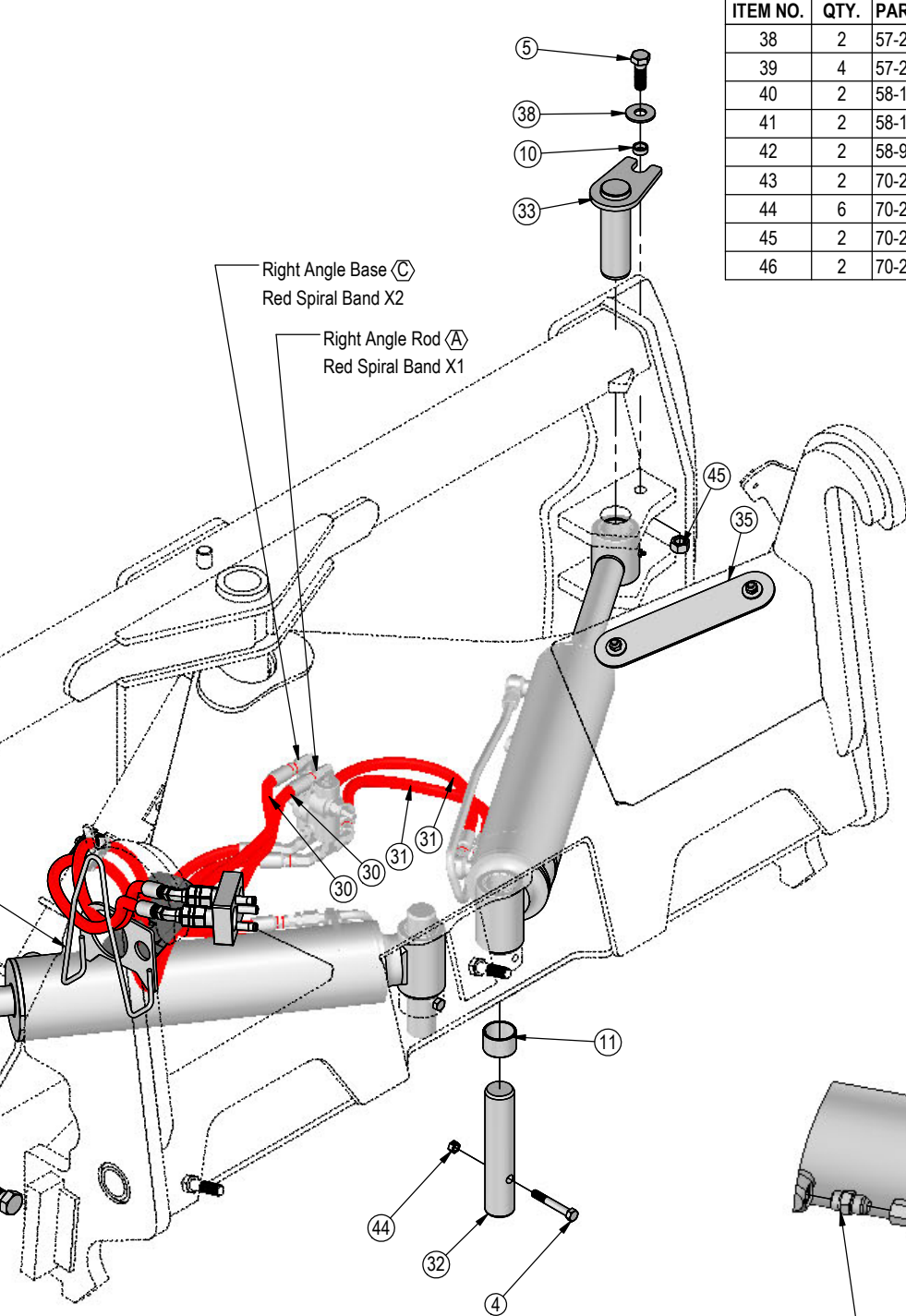

Note: View is from Multi-Coupler Installed on Top Arm.
All hoses are marked with colored spiral bands and should be attached to designated ports on the Multi-Coupler.

DWG. NO.: 19886

ITEM NO.	QTY.	PART NO.	DESCRIPTION
1	1	11-40866	Bell Crank
2	1	16-20011	1/4" X 2-3/4" Hex Bolt Gr 5 NC CZ
3	5	16-20035	5/16" X 1-1/4" Hex Bolt Gr 5 NC CZ
4	1	16-20038	5/16" X 2" Hex Bolt Gr 5 NC CZ
5	2	16-20130	1/2" X 2-1/2" Hex Bolt Gr 5 NC CZ
6	5	16-20560	1" X 2-1/2" Hex Bolt Gr 8 NC YZ
7	2	16-20561	1" X 2-3/4" Hex Bolt Gr 8 NC YZ
8	1	16-20562	1" X 3" Hex Bolt Gr 8 NC YZ
9	2	16-21065	3/8" x 1-1/4" Carriage Bolt Gr 5 NC CZ
10	4	16-21126	1/2" x 1-1/2" Carriage Bolt Gr 5 NC CZ
11	4	16-35C612	3/8" x 3/4" Flange Bolt
12	2	16-812525	M8-1.25 x 25mm Class 10.9 Hex Bolt CZ
13	5	18-19311-02-P-062	Half Hose Clamp
14	1	18-19311-02-P-062	Hose Clamp
15	6	18-19312-02	Twin Cover Plate
16	1	18-42046	Bottom Bracket
17	1	18-43719	Bracket, Hose Mount
18	1	18-43729R1	Bracket, Latch Stop
19	4	19-13577	NR Pin Spacer Clevis End
20	2	19-40440	.378" ID x .503" OD x .375" Spacer
21	2	19-7774	1" x 1" Spring Bushing
22	1	25-19657	Multi-Coupling Plate - 2 Port Parking Station
23	2	25-19865	Multi-Coupling Plate - Female Coupler
24	1	25-19869	Multi-Coupling Plate - 2 Port - Mobile
25	2	25-40407	Multi-Coupling Plate - Snap Ring
26	2	26-34747	4 x 8 Cylinder w/ Clevis Ends

Note: Every hydraulic function from front to back of system is designated by a letter and can also be referenced on the Hydraulic Schematic.

See Detail A for correct hose locations

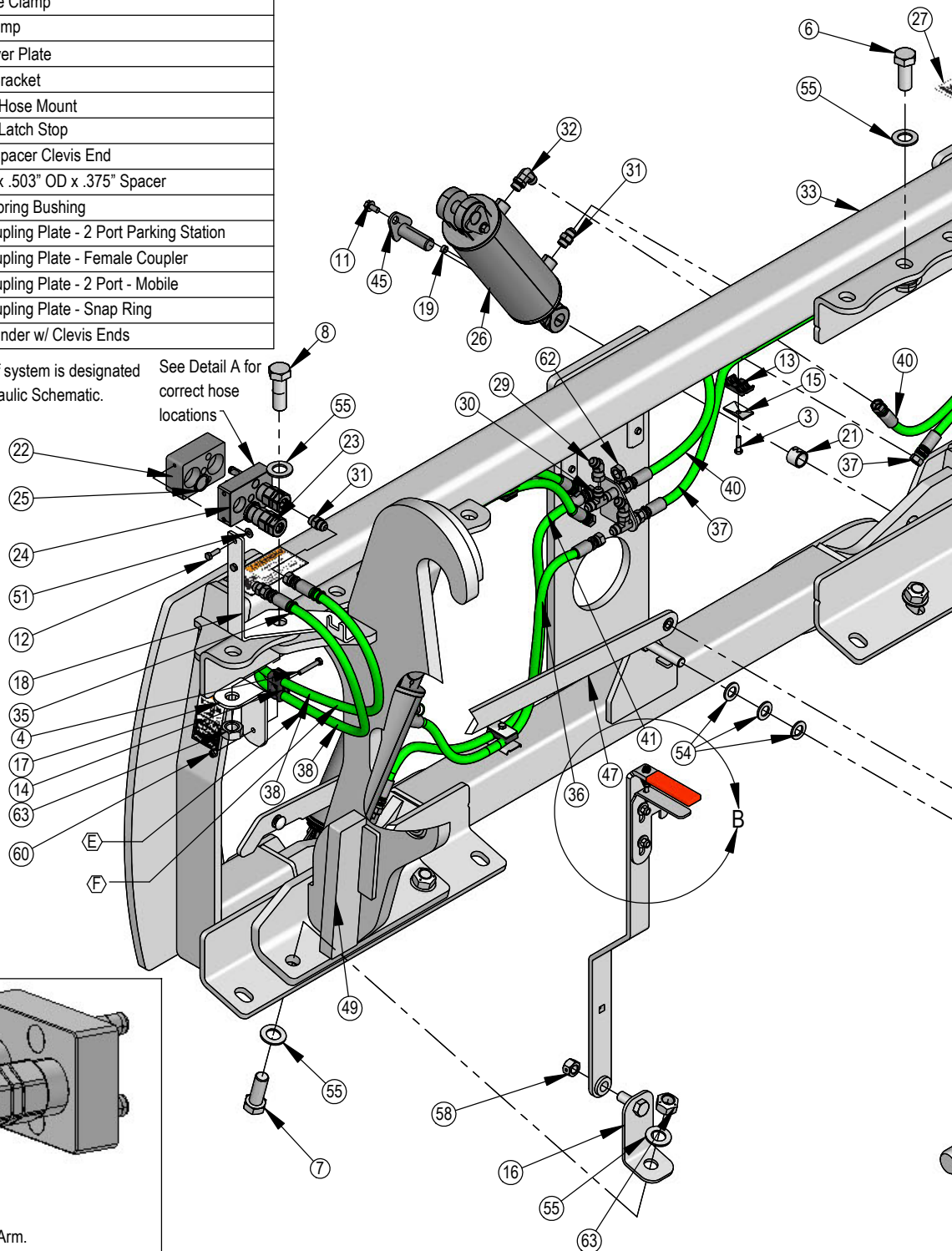

Detail A

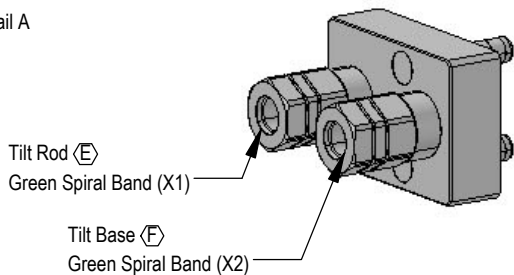

Note: View is from Multi-Coupler Installed on Top Arm.
All hoses are marked with spiral bands and should be attached to designated ports on the Multi-Coupler.

DETAIL B
SCALE 1 : 8

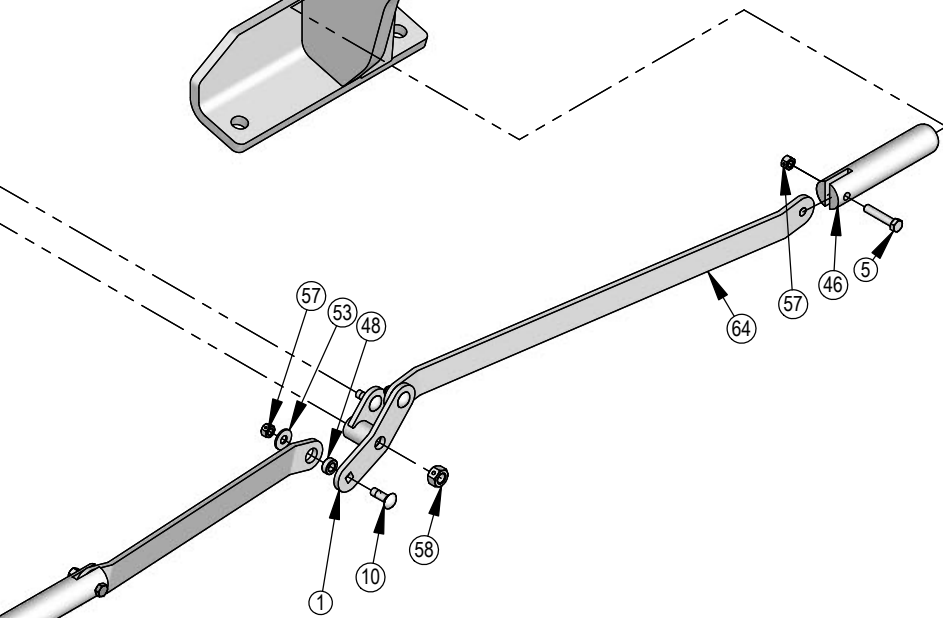
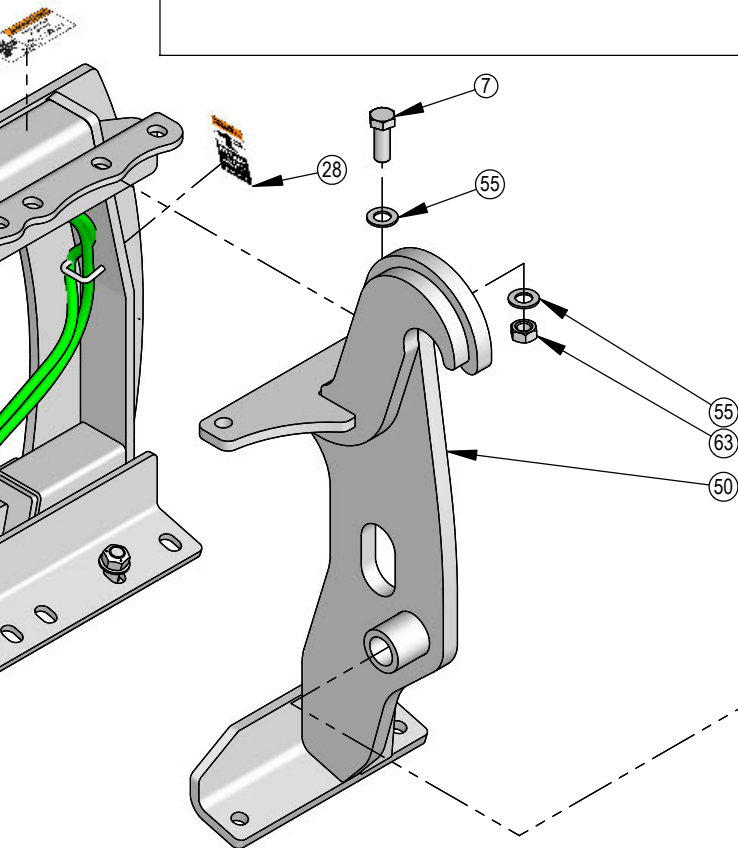
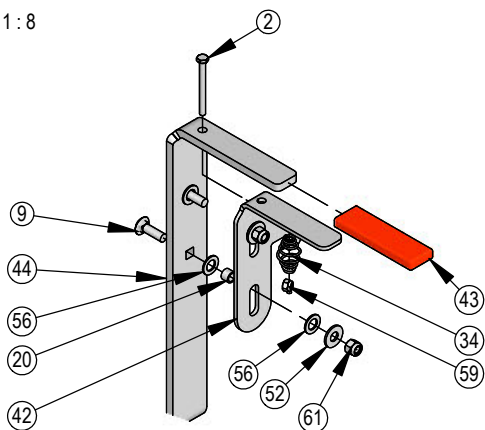

ITEM NO.	QTY.	PART NO.	DESCRIPTION
27	2	27-2409	Pinch Decal (Hand)
28	2	27-9503	Pinch Decal (Foot)
29	2	31-11492-8-8	Male JIC x Female JIC Swivel Nut Elbow 45°
30	2	31-34030	Bulkhead Run Tee JIC
31	4	31-34040	Straight JIC x O-Ring
32	2	31-34050	Straight Thread Elbow 90° JIC x O-Ring
33	1	32-18780	Tilt Frame Weld
34	1	34-17799	Latch Spring
35	12	34-18888-GR	-12 Green - Spiral Band
36	1	35-30021	36" x 3/8" -8JIC/-8JIC Hose
37	1	35-30033	72" x 3/8" -8JIC/-8JIC Hose
38	2	35-30035	78" x 3/8" -8JIC/-8JIC Hose
40	1	35-30036	80" x 3/8" -8JIC/-8JIC Hose
41	1	35-30079	40" x 3/8" -8JIC/-8JIC Hose
42	1	39-14663	Latch
43	1	39-3072	Rubber Handle
44	1	39-42050	Handle Weld
45	4	43-13580	Pin Weld
46	2	43-18486	Ag Pro SS QA Lock Pin
47	1	44-42049	Link, Handle to Bell Crank
48	4	44-8490	Spacer
49	1	45-40870-L	SS Bolt in Quick Attach - Left
50	1	45-40870-R	SS Bolt in Quick Attach - Right
51	2	57-20740	1/4" Flat Washer CZ
52	2	57-20742	3/8" Flat Washer CZ
53	4	57-20744	1/2" Flat Washer CZ
54	3	57-20757	3/4" SAE Hardened Flat Washer - 1-1/2" OD
55	15	57-20819	1" Flat Washer Heavy Duty Gr 8 (USS) YZ
56	4	57-40408	3/8" Flat Nylon Washer
57	6	70-20604	1/2" Hex Center Lock Nut Gr 5 NC CZ
58	2	70-20607	3/4" Hex Center Lock Nut Gr 5 NC CZ
59	1	70-20610	1/4" Nylock Hex Nut Gr 5 NC CZ
60	1	70-20611	5/16" Nyloc Hex Nut Gr 5 NC CZ
61	2	70-20612	3/8" Nyloc Hex Nut Gr 5 NC CZ
62	2	70-20807	3/4" Hex Jam Nut NF CZ
63	8	70-20999	1" Hex Top Lock Nut Gr 8 NC YZ
64	2	75-40869	Link, Bell Crank To Pin

Note: The cylinder part number is stamped on the base end of the cylinder opposite of the hydraulic ports.

Cylinder	Part No.	Description
26-34747	49-12271	Seal Kit 4x8 Nitrided Rod, Clevis Ends

DWG. NO.: 41668

Hydraulic Angle Blade Hydraulics

ITEM NO.	QTY.	PART NO.	DESCRIPTION
1	2	16-20037	5/16" x 2" Hex Bolt Gr 5 NC
2	2	16-20126	1/2" x 1-1/2" Hex Bolt Gr 5 NC
3	4	18-19311-03-P-087	Hose Clamp
4	2	18-19312-03	Twin Cover Plate
5	2	18-19313-03	Twin Stacking Bolt
6	2	18-19314-02	Twin Safety Plate
7	1	18-19315-R	Hose Guide Weld
8	4	25-19865	Multi-Coupling - Female Coupler
9	1	25-19866	Multi-Coupling Plate - 4 Port Mobile
10	4	25-40407	Multi-Coupling - Snap Ring
11	2	26-34741	3 x 48 Hydraulic Cylinder
12	4	31-13669-8-8	Male JIC 90° Elbow Bulkhead Fitting
13	4	31-34050	Straight Thread Elbow 90° JIC x O-Ring
14	4	31-34150	Straight Thread Elbow 45° JIC x O-Ring
15	2	34-17585	Cylinder Strap
16	6	34-18888-BL	-12 Blue - Spiral Band
17	6	34-18888-BR	-12 Brown - Spiral Band
18	1	34-19217	Rubber Seal
19	2	35-19357	121" x 3/8" -8JIC/-8JIC Hose
20	2	35-19358	113" x 3/8" -8JIC/-8JIC Hose
21	1	35-30012	27" x 3/8" -8JIC - 8JIC Hose
22	1	35-30023	42" x 3/8" -8JIC/-8JIC Hose
23	1	35-30029	60" x 3/8" -8 JIC/-8 JIC Hose
24	1	35-30079	40" x 3/8" -8JIC/-8JIC Hose
25	4	43-16306	Cylinder Pin w/ Cotter Pins
26	4	43-18943	3/16" x 1-1/2" Cotter Pin
27	4	43-7767	Cylinder Pin Clip
28	1	44-19218	Seal Clamp Plate
29	6	57-20744	1/2" Washer
30	4	70-20604	1/2" Center Lock Hex Nut
31	4	70-20807	3/4" Hex Jam Nut NF

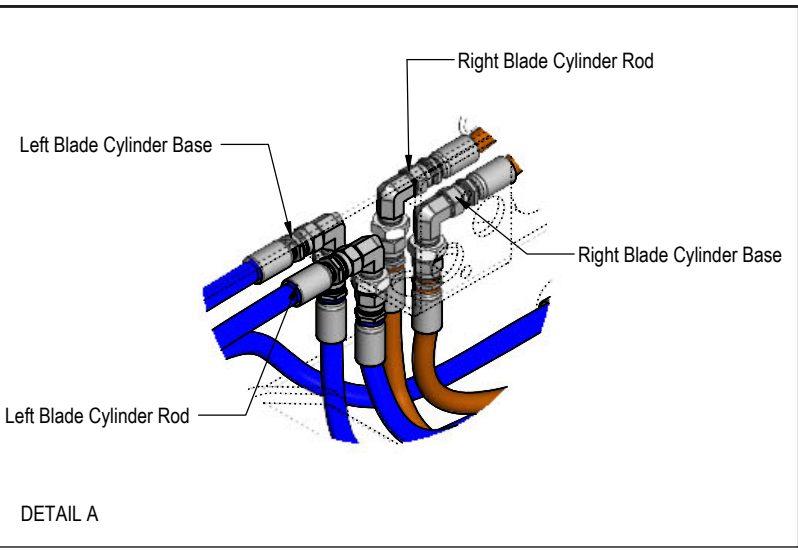

Note: Every hydraulic function from front to back of system is designated by a letter and can also be referenced on the Hydraulic Schematic.

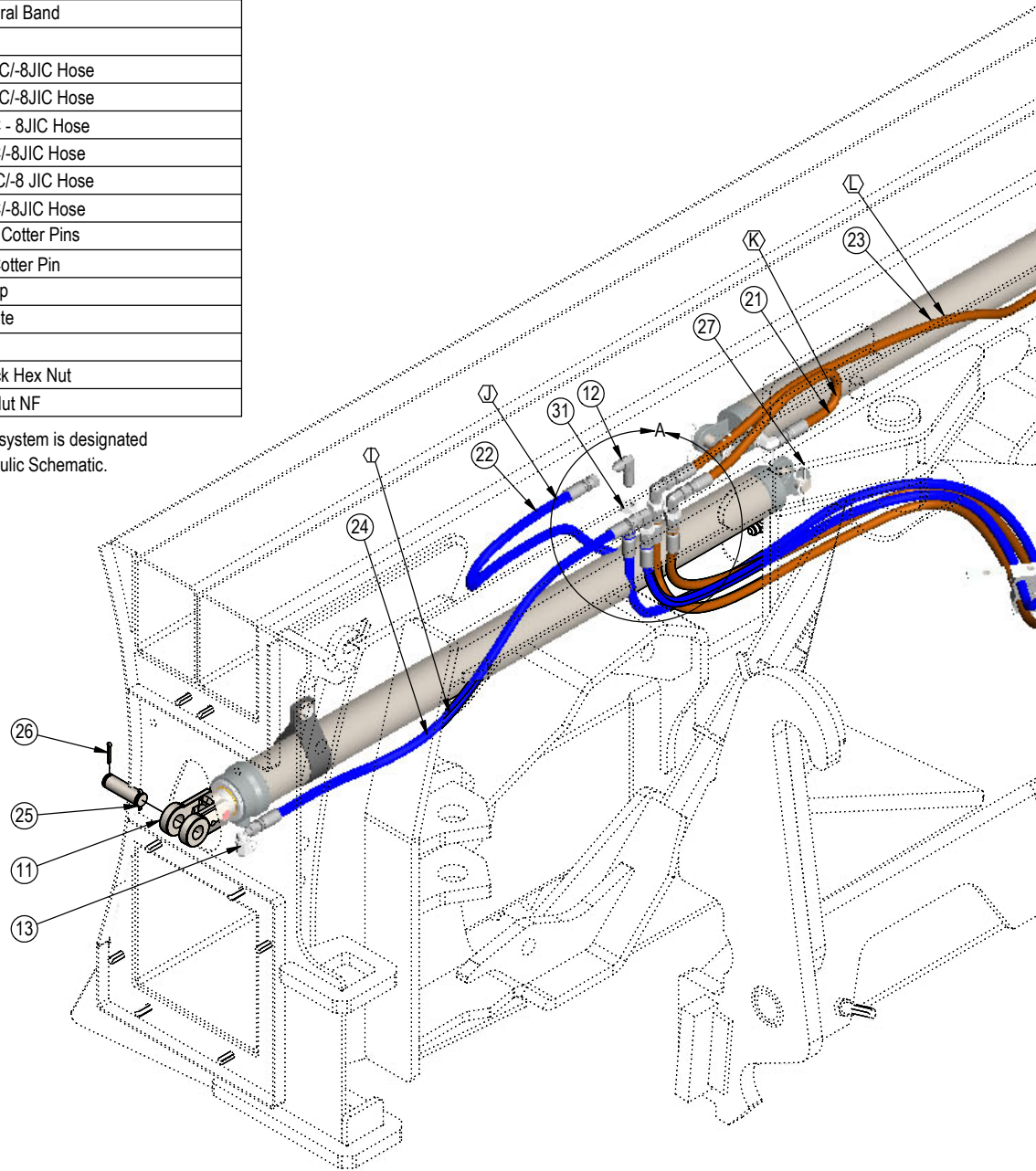

Note: The cylinder part number is stamped on the base end of the cylinder opposite of the hydraulic ports.

Cylinder	Part No.	Description
26-34741	49-19997	Seal Kit 3"

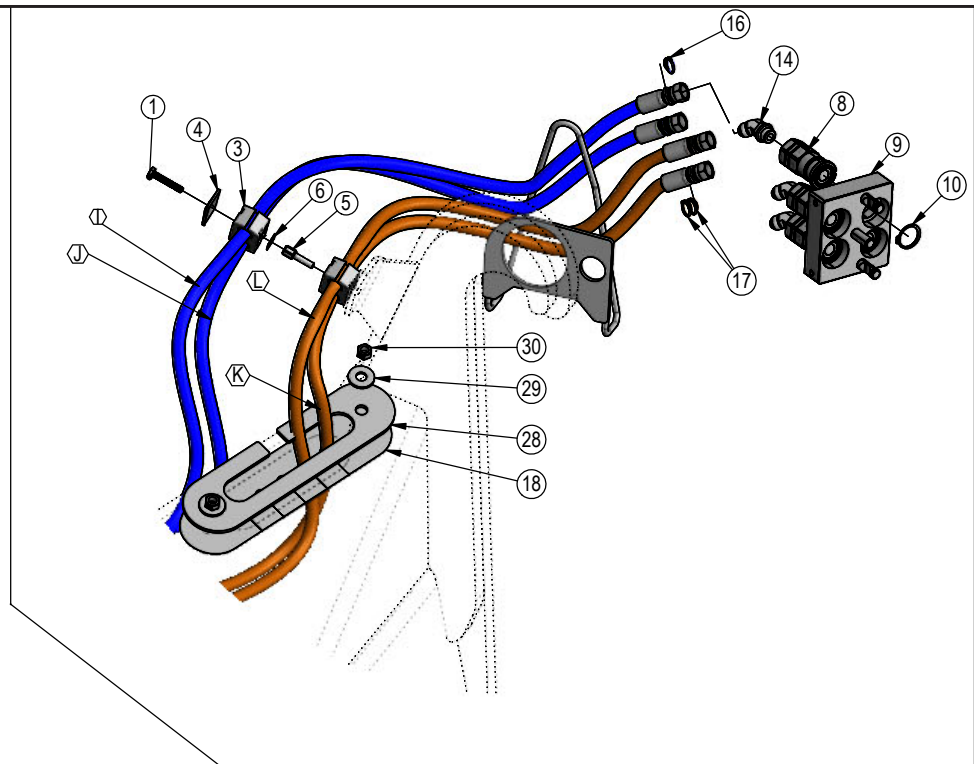
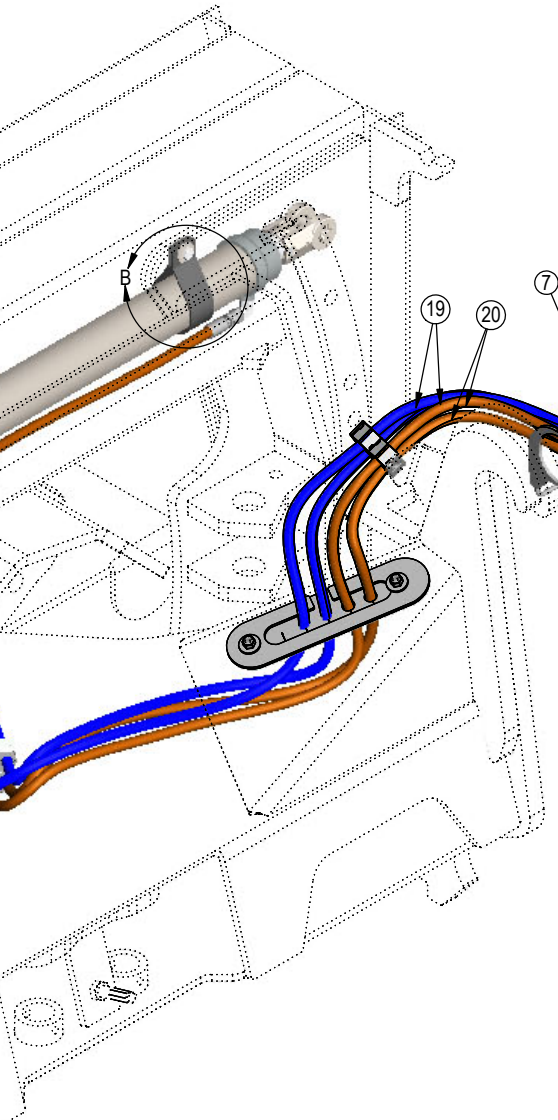

See Detail C for correct hose locations

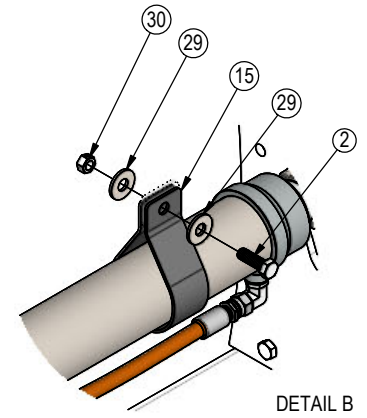

DETAIL B

DETAIL C

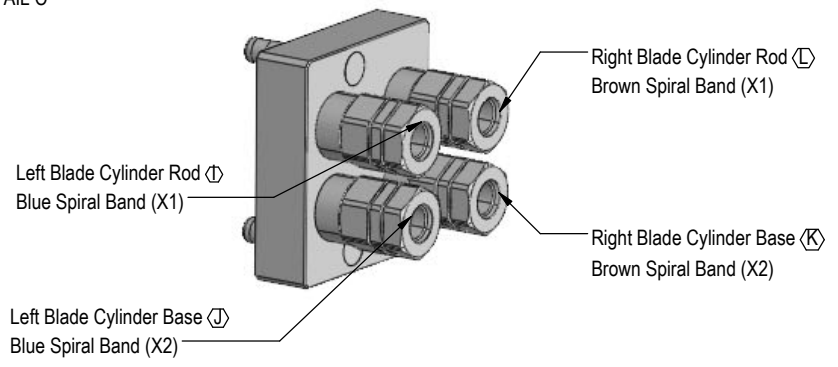

Note: View is from Multi-Coupler installed on Top Arm. All hoses are marked with colored spiral bands and should be attached to designated ports on the Multi-Coupler.

DWG. NO.: 19880

ITEM NO.	QTY.	PART NO.	DESCRIPTION
1	1	11-40866	Bell Crank
2	1	16-20011	1/4" x 2-3/4" Hex Bolt Gr 5 NC
3	2	16-20130	1/2" x 2-1/2" Hex Bolt Gr 5 NC
4	2	16-21065	3/8" x 1-1/4" Carriage Bolt Gr 5 NC
5	4	16-21126	1/2" x 1-1/2" Carriage Bolt Gr 5 NC
6	1	18-42046	Bottom Bracket
7	1	18-42048	Top Bracket
8	2	19-40440	.378" ID x .503" OD x .375" Spacer
9	2	27-2409	Pinch Decal (Hand)
10	2	27-9503	Pinch Decal (Foot)
11	1	34-17799	Latch Spring
12	1	39-14663	Latch
13	1	39-3072	Rubber Handle

ITEM NO.	QTY.	PART NO.	DESCRIPTION
14	1	39-42050	Handle Weld
15	2	43-18486	AG Pro SS QA Lock Pin
16	1	44-42049	Link, Handle to Bell Crank
17	4	44-8490	Spacer
18	2	57-20742	3/8" Flat Washer
19	4	57-20744	1/2" Washer
20	3	57-20757	3/4" Flat Washer - 1-1/2" OD
21	4	57-40408	3/8" Flat Nylon Washer
22	6	70-20604	1/2" Hex Center Lock Nut Gr 2 NC
23	2	70-20607	3/4" Center Lock Hex Nut Gr 2 NC
24	1	70-20610	1/4" Nyloc Hex Nut Gr 5 NC
25	2	70-20612	3/8" Nyloc Hex Nut Gr 5 NC
26	2	75-40869	Link, Bell Crank To Pin

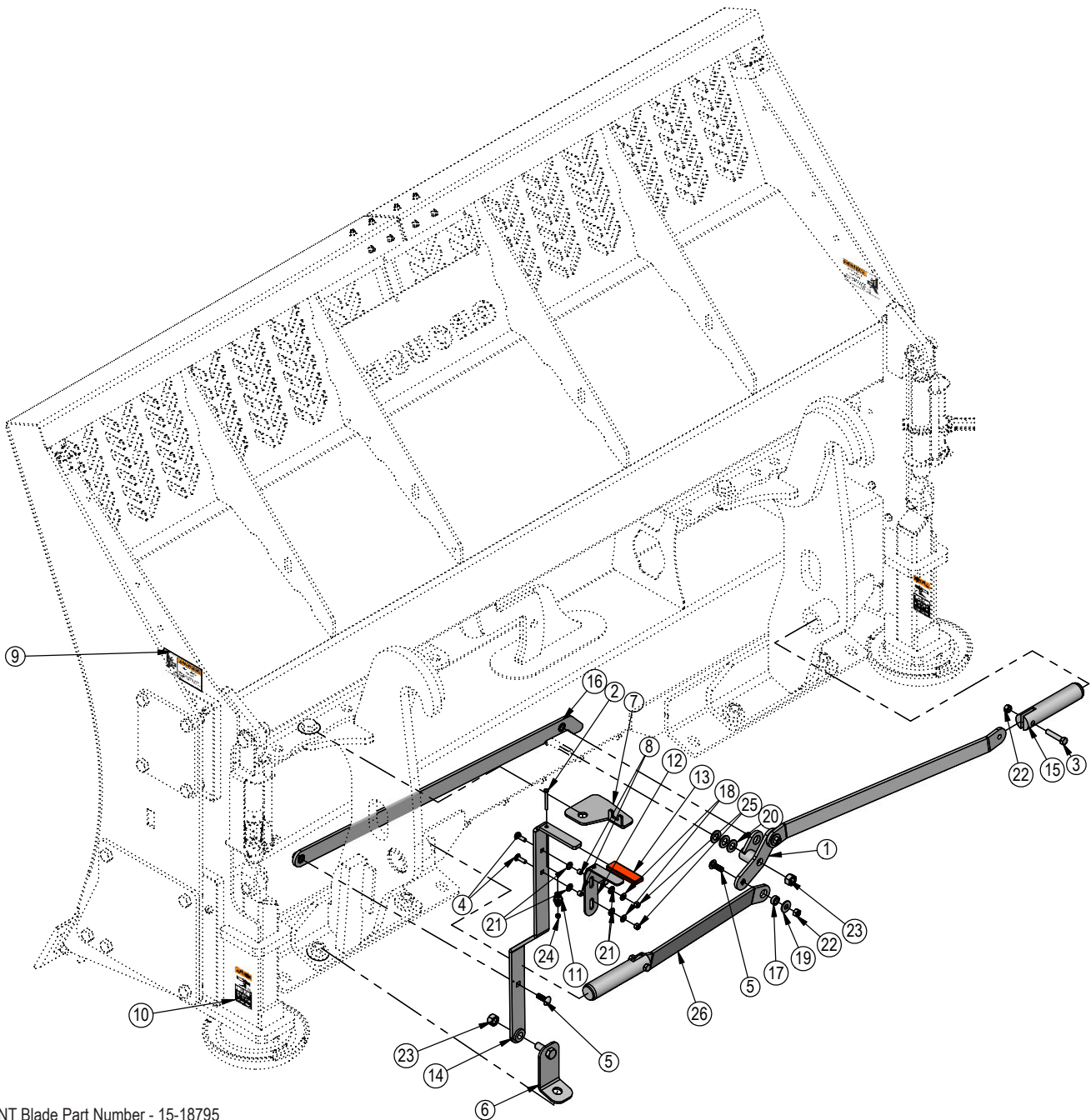

NANT Blade Part Number - 15-18795
 See Page 14-15 for parts related to blade assembly.

ITEM NO.	QTY.	PART NO.	DESCRIPTION
1	1	16-20043	5/16"X3-1/4" Gr.5 Hex Bolt
2	2	16-20126	1/2" x 1-1/2" Hex Bolt Gr. 5 NC
3	2	16-812525	8mm x 1.25mm x 25mm Metric Hex Bolt Gr 10.9
4	2	18-19311-02-P-062	Hose Clamp
5	2	18-19312-02	Twin Cover Plate
6	1	18-40589-R,L	Multi-Coupler Bracket
7	1	25-18956	Multi-Coupling Plate - 4 Port Parking Station
8	1	25-19866	Multi-Coupling Plate - 4 Port Mobile
9	2	26-34741	3 x 48 Hydraulic Cylinder
10	4	31-34040	Straight JIC x O-Ring
11	4	31-34050	Straight Thread Elbow 90° JIC x O-Ring
12	2	34-17585R1	Cylinder Strap

ITEM NO.	QTY.	PART NO.	DESCRIPTION
13	1	35-18938-0460	46" x 3/8" -8JIC x -8JIC Hose w/Cordura
14	1	35-18938-0900	90" x 3/8" -8JIC x -8JIC Hose w/Cordura
15	1	35-18938-1060	106" x 3/8" -8JIC x -8JIC Hose w/Cordura
16	1	35-18938-1380	138" x 3/8" -8JIC x -8JIC Hose w/Cordura
17	4	43-16306	Cylinder Pin w/ Cotter Pins
18	4	43-18943	3/16" x 1-1/2" Cotter Pin
19	4	43-7767	Cylinder Pin Clip
20	2	57-20740	1/4" Flat Washer
21	4	57-20744	1/2" Washer
22	2	70-20604	1/2" Hex Center Lock Nut Gr 2 NC
23	1	70-20611	5/16" Nyloc Hex Nut Gr 5 NC

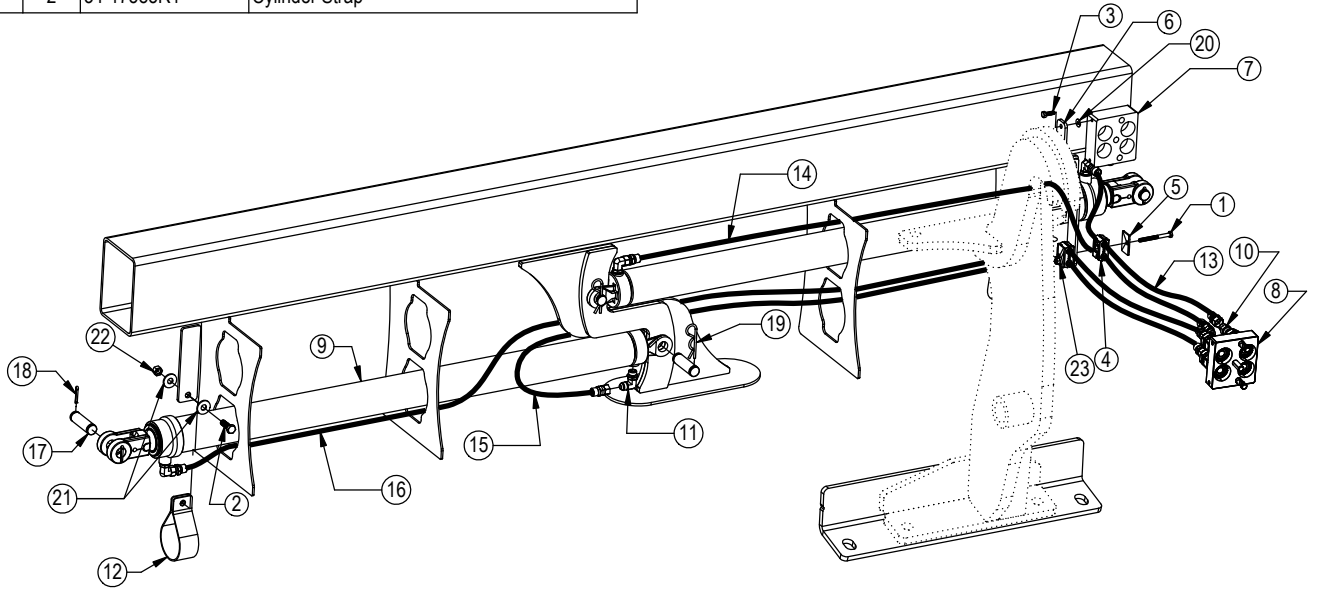

ITEM NO.	QTY.	PART NO.	DESCRIPTION
1	1	16-20043	5/16" x 3-1/4" Hex Bolt Gr. 5 NC
2	2	16-20126	1/2" x 1-1/2" Hex Bolt Gr. 5 NC
3	2	16-812525	8mm x 1.25mm x 25mm Metric Hex Bolt Gr 10.9
4	2	18-19311-02-P-062	Hose Clamp
5	2	18-19312-02	Twin Cover Plate
6	1	18-40589-R	Multi-Coupler Bracket
7	1	25-18956	Multi-Coupling Plate - 4 Port Parking Station
8	1	25-19866	Multi-Coupling Plate - 4 Port Mobile
9	2	26-34741	3 x 48 Hydraulic Cylinder
10	4	31-34040	Straight JIC x O-Ring
11	4	31-34050	Straight Thread Elbow 90° JIC x O-Ring
12	2	34-17585R1	Cylinder Strap

ITEM NO.	QTY.	PART NO.	DESCRIPTION
13	1	35-11686-0650	65" x 3/8" -8JIC x -8JIC Hose
14	2	35-11686-0850	85" x 3/8" -8JIC x -8JIC Hose
15	1	35-11686-1380	138" x 3/8" -8JIC x -8JIC Hose
16	4	43-16306	Cylinder Pin w/ Cotter Pins
17	4	43-18943	3/16" x 1-1/2" Cotter Pin
18	4	43-7767	Cylinder Pin Clip
19	2	57-20740	1/4" Flat Washer
20	4	57-20744	1/2" Washer
21	1	70-20611	5/16" Nyloc Hex Nut Gr. 5
22	2	70-20604	1/2" Hex Center Lock Nut Gr. 2

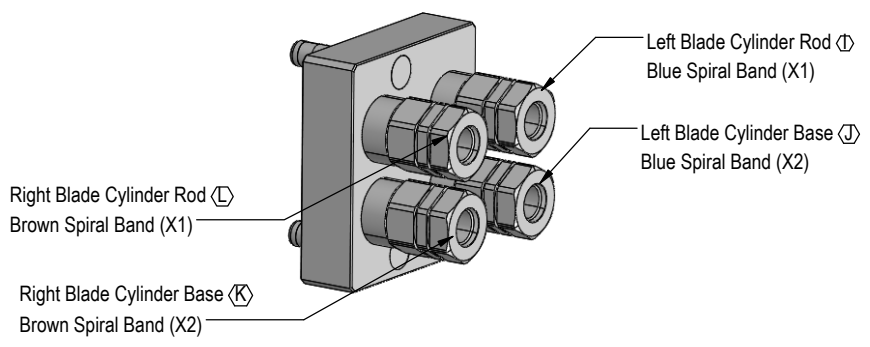
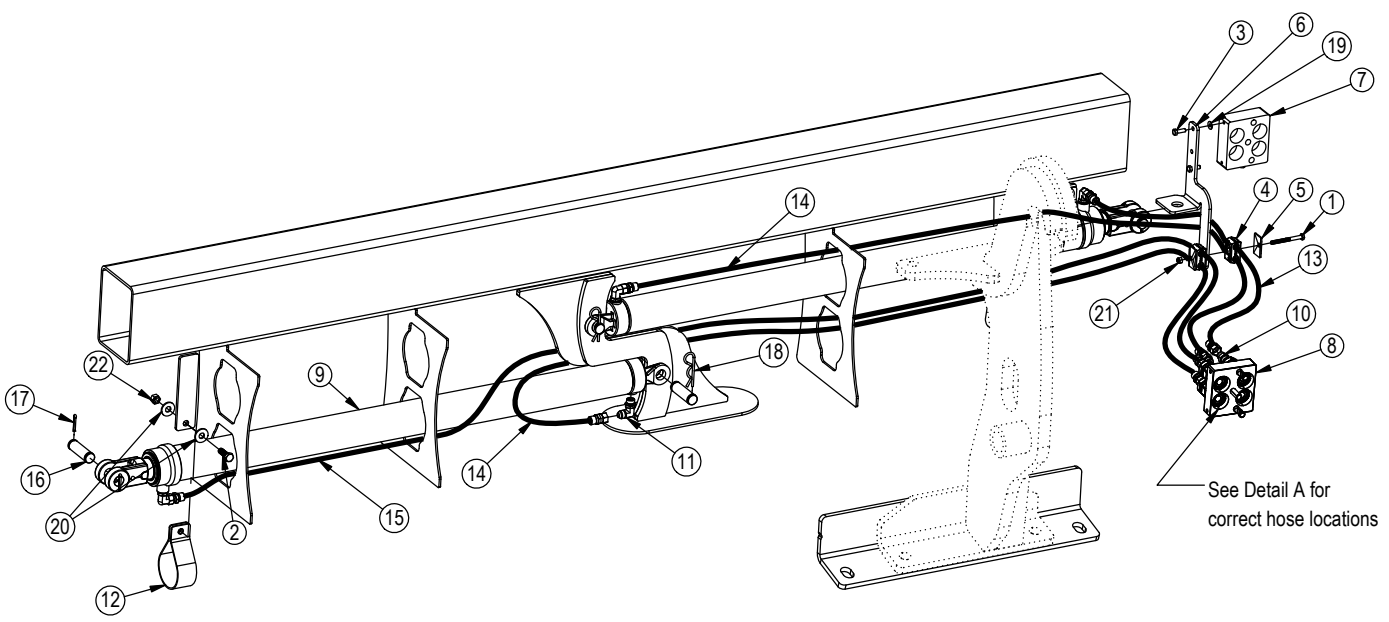

Note: View is from Multi-Coupler installed on Top Arm. All hoses are marked with colored spiral bands and should be attached to designated ports on the Multi-Coupler.

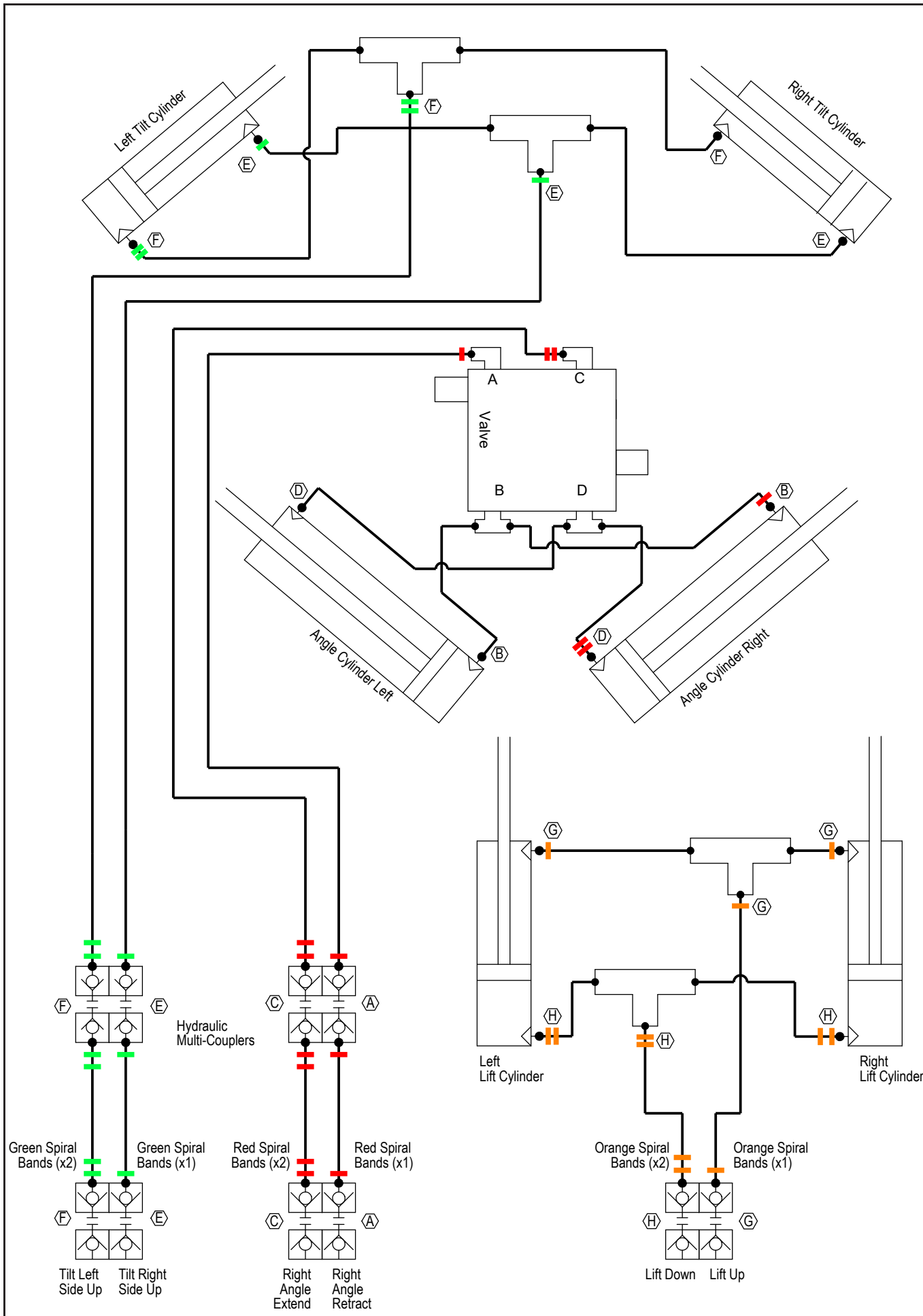

Tractor Service Valve

3-5 Blade Cylinders

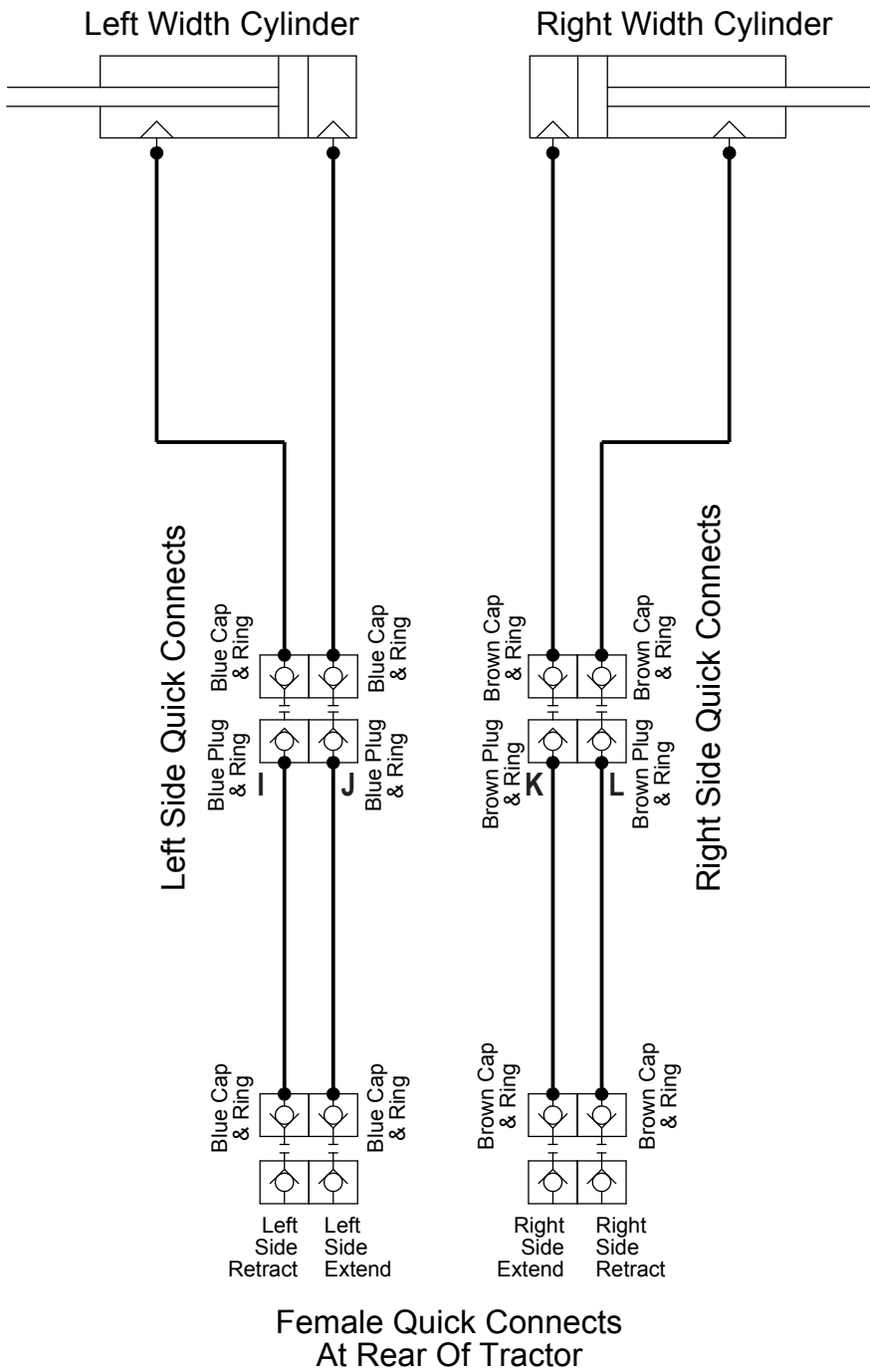

Before Each Use:

1. Disconnect the mobile half from the parking station and the cap from the fixed half.
2. Check that there is no contamination (salt, sand, dirt, etc.):
 - A. On the pins.
 - B. Inside the cam.
 - C. In the locking mechanism area.
 - D. On the face of the plates and couplings.
3. In case of contamination, remove it with a cloth and/or compressed air.
4. Check that there is still a lubricant/anti-corrosion (grease or silicone - see Note 1):
 - A. On the pins.
 - B. Inside the cam.
 - C. In the locking mechanism area.
5. Connect the mobile and fixed halves together.

Fixed Half

Mobile Half

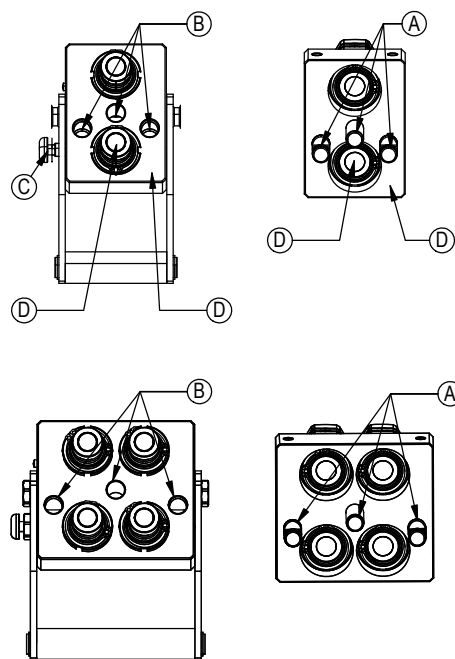

After Each Use:

1. Disconnect the mobile half from the fixed half.
2. Clean all contamination (salt, sand, dirt, etc.) from the following areas:
 - A. On the pins.
 - B. Inside the cam.
 - C. In the locking mechanism area.
 - D. On the face of the plates and couplings.

*Use a cloth or compressed air. It is advised to not use water to clean these surfaces
3. Apply a lubricant/anti-corrosion (grease or silicone - see Note 1):
 - A. On the pins.
 - B. Inside the cam.
 - C. In the locking mechanism area.
4. Connect the cap to the fixed half and the mobile half to the parking station.

Note 1:

When sand and salt are present, or the plates under go a washdown, a heavy duty silicone spray lubricant should be used to replace grease from the factory. The lubricant should help protect from corrosion without collecting dust and contaminants, and will resist washing off when exposed to water.

Recommended Lubricant Brands:

Fluid Film (Aerosol or Non-Aerosol), LPS-2 Heavy Duty Lubricant, or CRC 3-36.

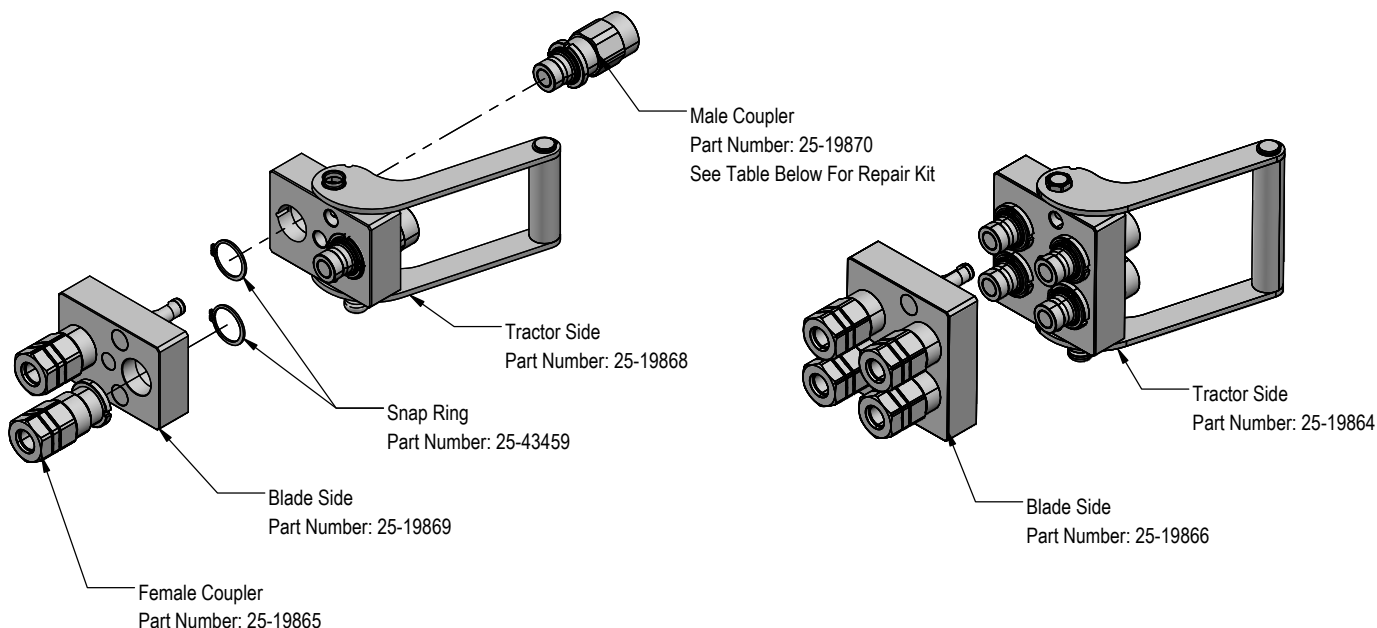

PN	Description
25-43425	Male Coupler O-Ring Repair Kit

Cleaning The Male Interface Seal:

1. Make sure the coupling is securely fastened into the plate or place in a vice.
2. Using a blunt, non-marring tool, depress the valve face until the seal is exposed. Insert a bent metal wire between the valve face and the body of the coupling. Use caution not to damage or scratch the seal when inserting the wire.
3. Inspect the seal and interior surfaces for contamination.
4. In case of contamination, carefully wipe surfaces with a soft cloth, or use compressed air to blow the contamination out. Do Not press hard on the seal as contamination can scratch the seal surface.
5. Using a non-marring tool, depress the valve face and remove the metal wire. Release the valve to the flush position.



Cleaning The Female Bushing:

1. Make sure the coupling is securely fastened into the plate or place in a vice.
2. Using a non-marring tool, depress the outer ring to expose the bushing. There is no need to expose the valve seal, so stop pressing before the valve is opened.
3. Inspect the interior body and bushing surfaces for contamination.
4. In case of contamination, carefully wipe surfaces with a soft cloth, or use compressed air to blow the contamination out.
5. Release the outer ring so that it returns to the flush position.



Improvements

Grouser Products Inc. is continually striving to improve its products. We reserve the right to change prices, specification, or equipment at any time without notice. We also reserve the right to make improvements or changes when it becomes practical and possible to do so without incurring any obligation to make changes or additions to the equipment sold previously.

Warranty

Grouser Products warrants to the original purchaser of each item that the product be free from defects in material and workmanship under normal use and service for a period of **two (2) years for Agriculture Series Blades and one (1) year for Heavy Duty Series from date of original retail delivery.**

The obligation of the consumer under this warranty:

1. To read the operators manual and to operate, lubricate, maintain and store equipment in accordance with the instructions listed in the operators manual.
2. To inspect equipment and if any part needs repair or replacement when continued use would cause damage or wear to other parts or safety.
3. All equipment or parts claimed to be defective in material or workmanship must be made available for inspection at the place of business of a dealer authorized to handle the equipment covered by this warranty, or, upon request by Grouser Products, shipped to the Grouser Products factory in West Fargo, North Dakota.

The obligation of the dealer under this warranty:

1. Complete warranty registration form and submit within 30 days of sale.
2. Contact Grouser Products for authorization prior to performing any warranty repairs or part replacement.
3. Complete warranty request form and submit with photos and supporting documentation.

The obligation of Grouser Products under this warranty:

1. Repair or replace, any equipment or parts, in the judgment of Grouser Products to be defective in material or workmanship.
2. Grouser Products will cover the cost of parts and ground shipping at dealer invoice only.
3. Grouser Products shall have no obligation to bear the cost of labor or transportation in connection with replacement or repair of any such defective parts.

This warranty does not cover:

1. Depreciation or damage caused by normal wear, accident, improper assembly, improper adjustments.
2. Improper maintenance including lack of proper lubrication, or improper use. Including loose bolts, nuts, or fitting due to over tightening or vibration after 20 hours of operation.
3. Repairs or alterations without authorization from a Grouser Products representative.
4. Grouser Products shall have no liability if the equipment has been altered or reworked without the written authorization of Grouser Products.

Grouser Products' parts, which are furnished under this warranty and properly installed, shall be warranted to the same extent as the original parts under this warranty if, and only if, such parts are found to be defective within the original warranty period covering the original equipment.

NO EMPLOYEE OR REPRESENTATIVE OF GROUSER PRODUCTS IS AUTHORIZED TO CHANGE THE WARRANTY IN ANY WAY OR GRANT ANY OTHER WARRANTY.

Contact Us

As always, if you have any questions about your system or other products made by Grouser, feel free to contact us.



755 2nd Ave NW - West Fargo, ND 58078
+1 701-282-7710 | info@grouser.com
www.grouser.com