



John Deere 9RX Ag Pro Undercarriage Installation Instructions

For Models:

John Deere 9RX: 9RX 490, 9RX 540, 9RX 590, 9RX 640

Model Year 2022-Current

Purchase Date
Serial Number
Model Number
Tractor Model
Dealer

To The Owner

This manual contains information concerning the installation of the undercarriage. You have purchased dependable, long lasting equipment, but only by proper care and operation can you expect to receive the performance and long service built into our products. Please have all operators read this manual carefully and keep the manual available for ready reference. If you have any questions or concerns, contact Grouser Products.

Caution:

- Always use caution when working around any equipment.
- Always wear safety glasses.
- Follow tractor manufacturer's safety guidelines when installing this product.
- Use paint where necessary to prevent rust.
- Do not modify or permit anyone else to modify or alter the equipment and its components without first consulting Grouser Products.
- Operate within your own capabilities. Recommended operating speed is 3-5 MPH (5-8 km/h).

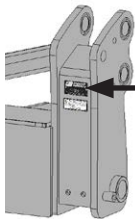

Serial Number Location

Note:

- When installing hardware, only finger tighten until all hardware is in place.
- A full diagram of the assembly with the full list of parts is on pages 6-7.
- Unstrap and remove any components that are attached for shipping.
- Read all instructions prior to performing installation.
- Tractor frame not shown in some diagrams for clarity.
- The tracks may need to be rotated up or down to gain better access at some bolting locations



To ensure the safety of those working under and around the machine, apply parking brake, and remove key from ignition before working on the machine.

Installation

1. If applicable, remove front weights, weight bracket, and toolbox from front of tractor.
2. Remove cable holder behind front axle if applicable. Keep spacer and washer to reinstall later.

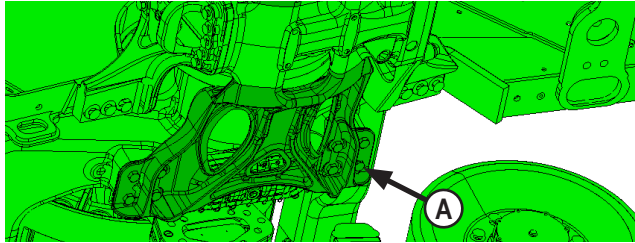

3. If applicable, remove front axle support brackets from front of tractor (A).

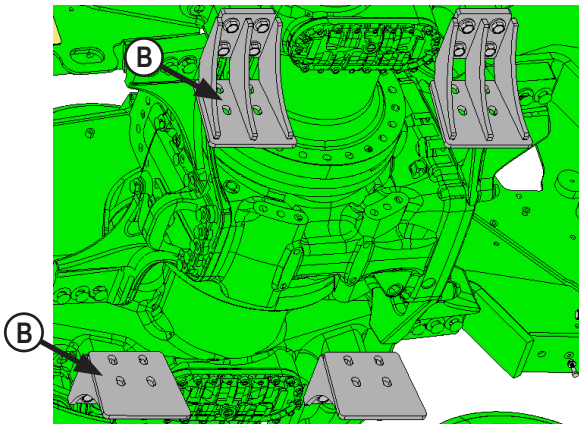

4. Attach final drive brackets to final drive with 16 - 20mm x 60mm bolts and 16 - hardened flat washers (B).
5. Push brackets away from tractor frame to make room for installing undercarriage.

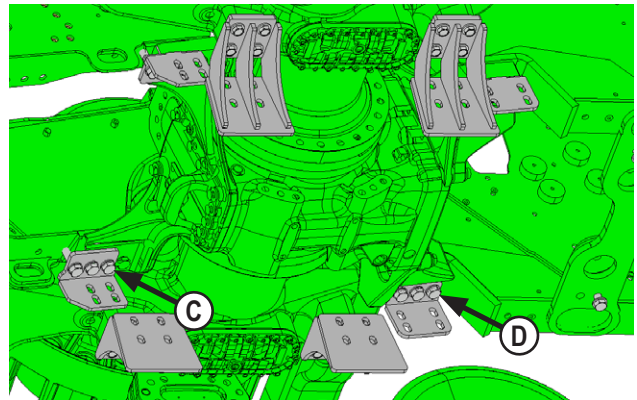

NOTE The orientation of left and right front brackets is important. Install the brackets as shown above.

NOTE: When removing front tractor axle frame bolts, always leave rear bolt in on each side.

6. Remove front 3 tractor axle frame bolts on each side and attach the front brackets to front 3 holes on the tractor frame in front of the axle with 6 - 24mm x 100mm bolts and 6 - 7/8" hardened washers (C).

NOTE: When removing rear tractor axle frame bolts, always leave front bolt in on each side.

7. Remove rear 3 tractor axle frame bolts on each side and attach rear brackets to 3 holes on tractor frame behind axle with 6 - 24mm x 100mm bolts and 6 - 7/8" hardened washers (D).
8. Push brackets towards center to make room for installing undercarriage.

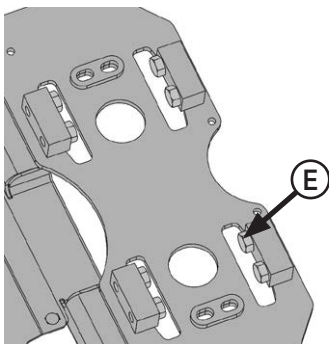

9. Completely thread 8 - 1" x 2" adjustment bolts (E) at rear of undercarriage with heads facing towards each other. The bolts will be adjusted after undercarriage is installed.
10. Position undercarriage under tractor and center on frame of the tractor. Lift undercarriage until holes of undercarriage line up with holes in side of tractor frame.

NOTE: When lifting undercarriage, watch for potential pinching of hoses or other components to prevent any damage.

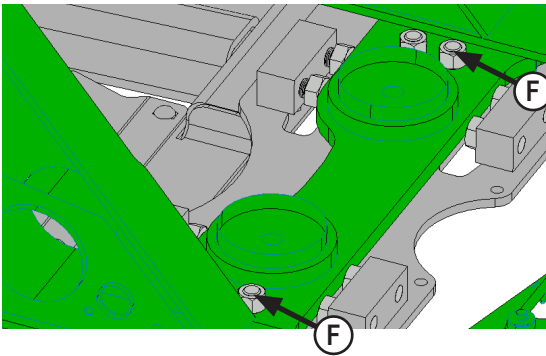

11. Attach rear of undercarriage vertically to cross member on tractor frame behind rear axle with 4 - 7/8" x 3" bolts, 8 - 7/8" hardened flat washers, and 4 - 7/8" nuts (F).

NOTE: Add shims between undercarriage and tractor frame to reduce any gap if necessary. Use shims until there is a gap of 1/16" or less on front. See attached diagram for proper location and orientation of each shim. Do Not put all of shims on one side of undercarriage.

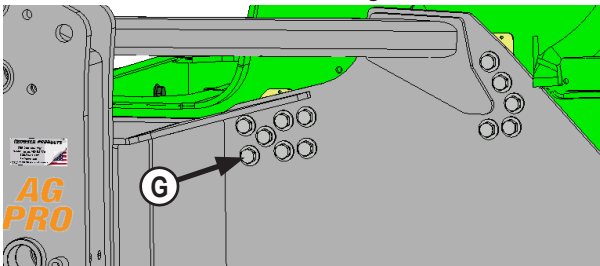

NOTE: Follow Steps #12-16 for left side. After Step #16, tighten bolts until they are snug. If necessary, add more shims on right side until a gap of 1/16" or less is on right side. Proceed with Step #12-16 for right side.

12. Install 14 - 3/4" x 3-1/2" bolts and 14 - 3/4" hardened HD flat washers (G) through front holes on each side of undercarriage, shims, and tractor frame.
13. Thread each bolt into front threaded plate. See full assembly diagram on Page 6 for correct orientation of plate. The side with the notch should be towards the front.

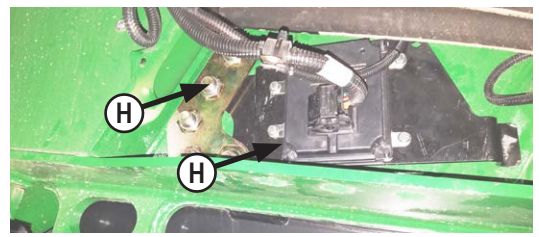

14. If there is a controller for drive shaft sensor on left inside frame of tractor, remove original hardware and reattach with new hardware in Step #15-16. Install controller between tractor frame and new nut plate.
15. Install 5 - 3/4" X 3" bolts and 5 - 3/4" hardened HD flat washers (H) through slots on each side of undercarriage, shims, and tractor frame.

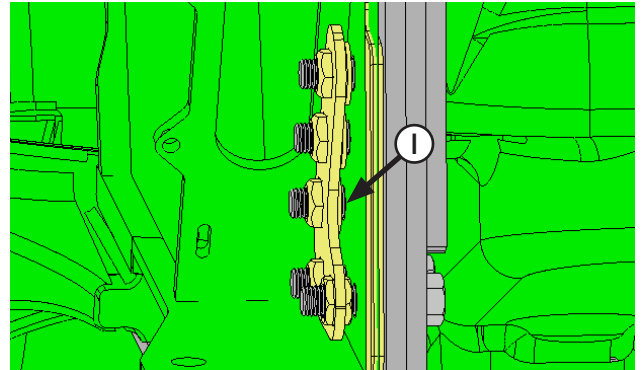

16. Place controller from Step #14 on bolts and thread a 3/4" flange nut on top 4 bolts from Step #15. Attach nut plate to bottom bolt and line up top hex nuts to fit in nut plate (I). Note orientation of flange nuts.

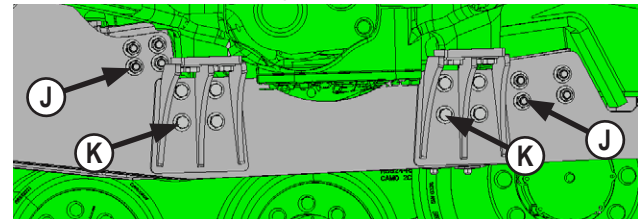

17. Attach front and rear brackets (J) to inside of undercarriage and final drive brackets (K) to outside of undercarriage with a 32 - 3/4" x 2-1/4" bolt, 64 - 3/4" hardened HD flat washers, and 32 - 3/4" nuts.
18. Torque rear vertical 7/8" bolts (F) to 600 ft-lbs.
19. Torque front 24 - 3/4" bolts (G & I) to 380 ft-lbs.
20. Torque all of 3/4" bolts (J & K) attaching brackets to the undercarriage to 380 ft-lbs. Alternate between groups of bolts when torquing. For example, torque front left bracket bolts, rear right bracket bolts, rear left bracket bolts, front right bracket bolts. Do same routine for final drive bracket bolts.
21. Torque vertical 24mm bolts (C & D) to 909 ft-lbs., and vertical 20mm bolts (B) to 432 ft-lbs.

NOTE: If available, John Deere service tool JDG650 (shown below) can be used to torque the vertical 24mm bolts.



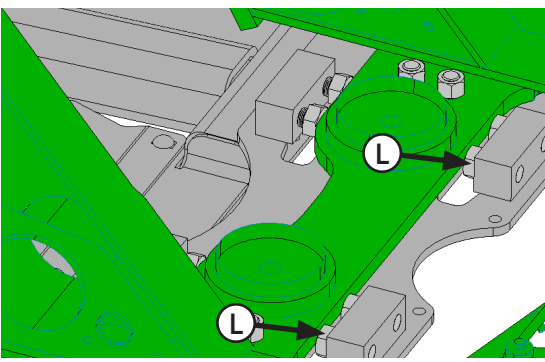

22. Unscrew 1" x 2" bolts (L) at rear of undercarriage until they are tight against tractor frame. Torque 1" bolts to 200 ft-lbs.

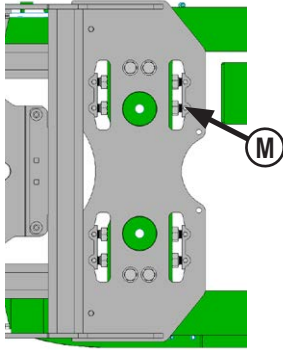

NOTE: View is from underneath tractor and undercarriage.

23. Install 2 - 5/16" x 3/4" bolts (M) into blocks at rear of undercarriage to lock each 1" x 2" bolt in place. Torque 5/16" bolts to 19 ft-lbs.

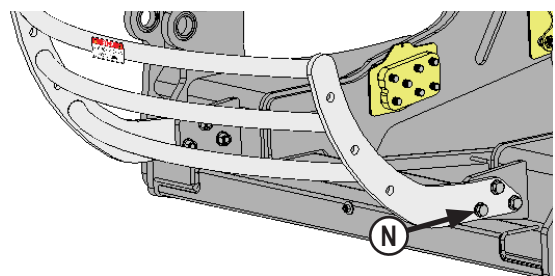

24. Install grill guard to front of undercarriage with 6 - 3/4" x 2-1/2" bolts, 12 - 3/4" flat washers and 6 - 3/4" nuts (N).

25. Torque 3/4" bolts (T) to 257 ft-lbs.

NOTE: If applicable, refer to Page 5 to attach front of tow cable.

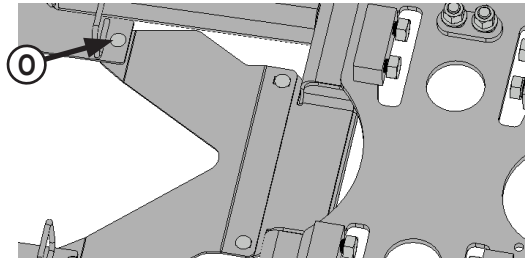

26. Install hose guard plate to rear of undercarriage with 4 - 1/2" x 1" carriage bolts, 4 - 1/2" washers and 4 - 1/2" nuts (O). Install bolts from top. Torque 1/2" nuts to 78 ft-lbs.

NOTE: To perform John Deere's 9R Upper Retainer Improvement (PIP #19RW830), remove the hose guard plate from Step #26. After the PIP is complete, reinstall hose guard plate.

Hose Routing

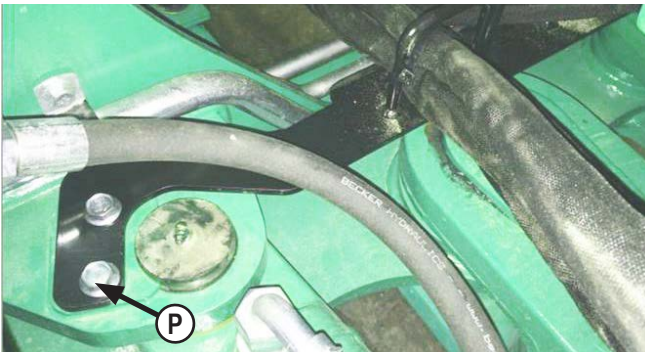

1. At pivot area of tractor, remove bolts from top plate that hold the cylinder pins and install hose routing bracket along with original plate and new 12mm flange bolts. Torque 12mm bolts to 105 ft-lbs (P).

2. Route hoses through hose loops on undercarriage until you reach end of undercarriage as shown in Step #3.



3. Route hoses toward center and attach to undercarriage with a heavy zip tie (Q).

4. Route hoses up through hose loops on bracket that was installed in Step #1

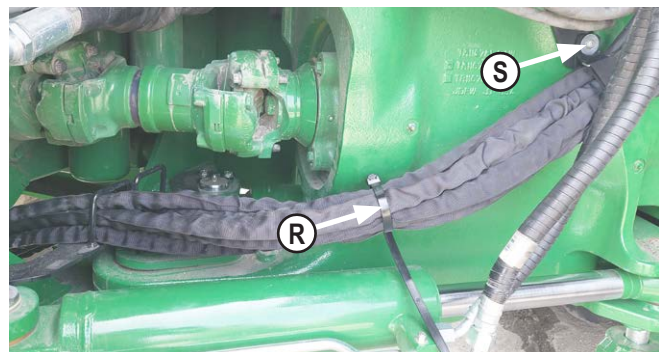

5. Route hoses upward through tractor. Staying away from the driveshaft. Group hoses together with zip ties (R). Remove bottom bolt from guard and bolt on velcro strap with a fender washer and original bolt. Secure hoses with strap (S).



6. Route hoses through open cavity of back section of tractor. Secure hoses with zip ties where necessary to avoid rubbing and pinch areas. Plug hoses into open SCV's at back of tractor.



7. Secure hoses with a velcro strap (T) above rear axle with original hardware.

NOTE: If unable to bolt velcro strap is location shown, secure hoses in a different location that keeps hoses from rubbing on any sharp edges.

8. Turn and articulate tractor in both directions to verify hoses have enough slack and are not being pinched around pivot area. Adjust velcro strap if necessary.

NOTE: The quantity of hoses may vary depending on blade system.

Special Note:

John Deere 9R tractors (non scraper versions) can experience a condition that will cause a cavitation or squealing in the hydraulic pump. The symptoms could be a chatter when operator raises their blade, the blade wanting to ride up the pile, or a delay in lift.

If you experience these conditions, please refer to John Deere Accumulator Kit BRE10185.

Assembling Lift Components

Refer to the Blade Owner's Manual & Parts Book for instructions on how to assemble the lift components.

Maintenance

1. After first 8 hours of use, re-torque all bolts.
2. Check all fasteners regularly to ensure proper operation of equipment.
3. Inspect all equipment for existing or potential damages every 10 hours or less.

Tow Cable Support Bracket Assembly

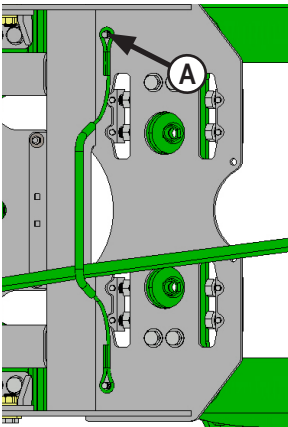

NOTE: Kit (PN: 41788-A) is required if tractor has a tow cable.

1. Reinstall cable holder with original spacers and washers and use new 2 - 3/8" x 1-3/4" bolts, 2 - 3/8" washers and 2 - 3/8" flange nuts at rear of undercarriage (A). Torque bolts to 47 ft-lbs.

NOTE: Original spacers and washers are not shown in picture.

2. Attach tow cable bracket and tow cable as shown below. Torque 7/8" bolts to 600 ft-lbs.

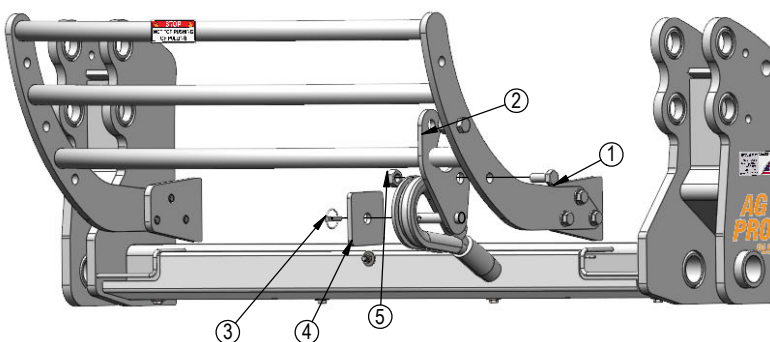

Tow Cable Support Bracket Assy - 18-41788-A			
ITEM NO.	QTY.	PART NO.	DESCRIPTION
1	2	16-20538	7/8" x 2" Hex Bolt Gr 8 NC
2	1	18-41788	Tow Cable Bracket
3	1	43-16764	7/16" x 1-3/4" Lynch Pin
4	1	44-15585	Plate
5	2	70-20598	7/8" Hex Nut Gr 8 NC

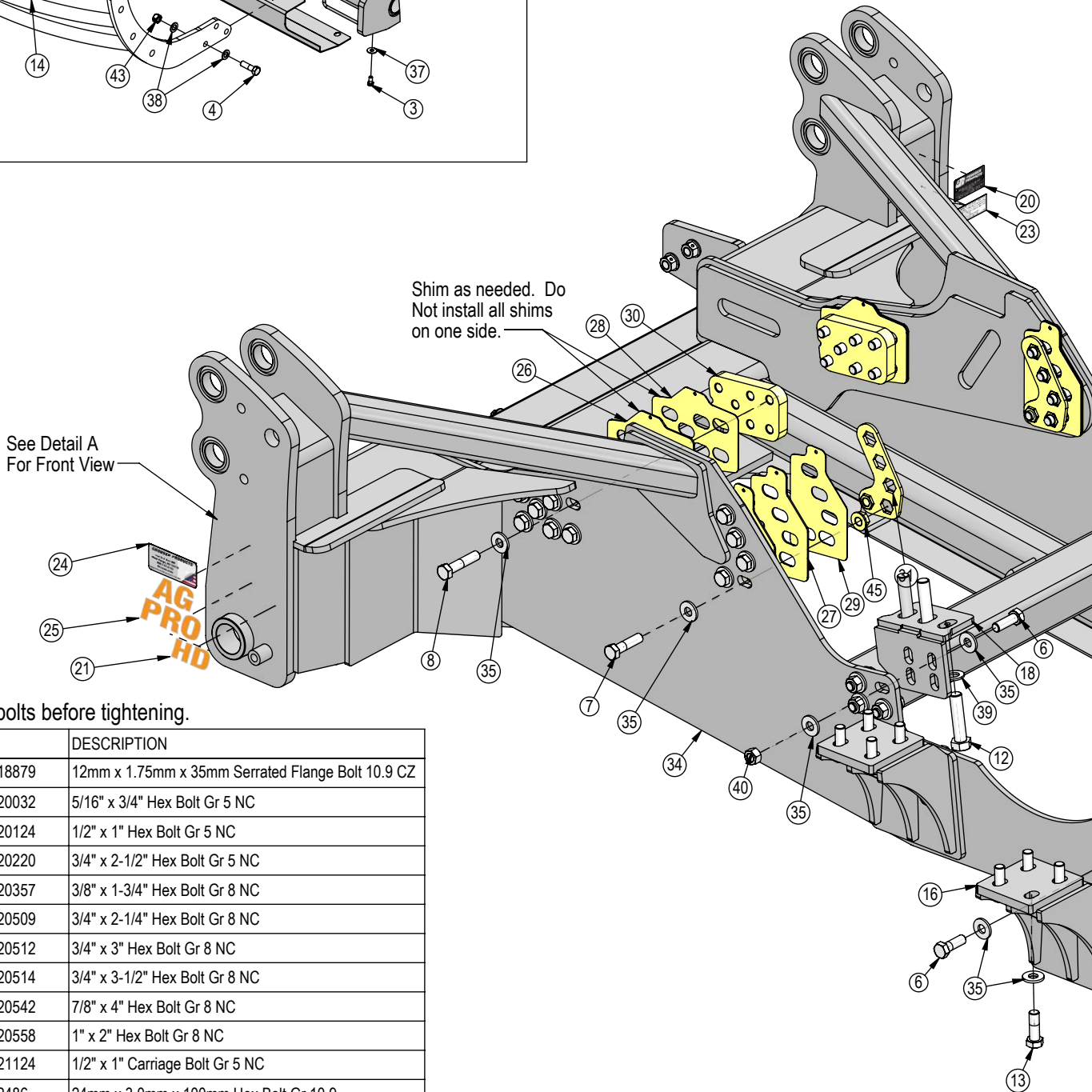
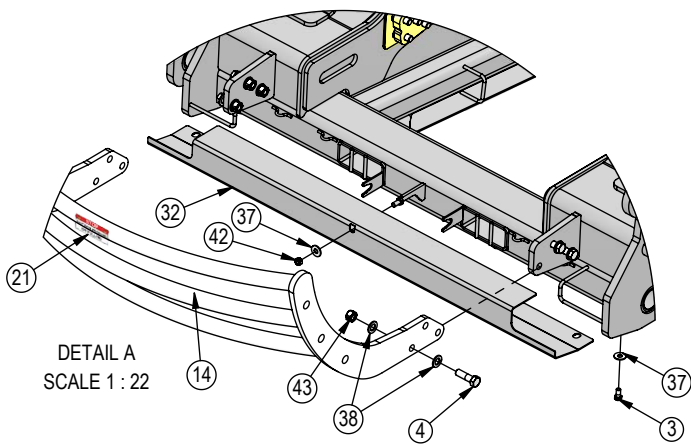

Note: Install all bolts before tightening.

ITEM NO.	QTY.	PN	DESCRIPTION
1	4	16-18879	12mm x 1.75mm x 35mm Serrated Flange Bolt 10.9 CZ
2	8	16-20032	5/16" x 3/4" Hex Bolt Gr 5 NC
3	4	16-20124	1/2" x 1" Hex Bolt Gr 5 NC
4	6	16-20220	3/4" x 2-1/2" Hex Bolt Gr 5 NC
5	2	16-20357	3/8" x 1-3/4" Hex Bolt Gr 8 NC
6	32	16-20509	3/4" x 2-1/4" Hex Bolt Gr 8 NC
7	10	16-20512	3/4" x 3" Hex Bolt Gr 8 NC
8	14	16-20514	3/4" x 3-1/2" Hex Bolt Gr 8 NC
9	4	16-20542	7/8" x 4" Hex Bolt Gr 8 NC
10	8	16-20558	1" x 2" Hex Bolt Gr 8 NC
11	4	16-21124	1/2" x 1" Carriage Bolt Gr 5 NC
12	12	16-2486	24mm x 3.0mm x 100mm Hex Bolt Gr 10.9
13	16	16-2487	20mm x 2.5mm x 60mm Hex Bolt Gr. 10.9
14	1	18-18059	Grill Guard Weld
15	1	18-18415	Bracket
16	4	18-19100	9RX Final Drive Bracket
17	2	18-43508	Rear Bracket Weld
18	1	18-43305-L	Front Bracket, Left
19	1	18-43305-R	Front Bracket, Right

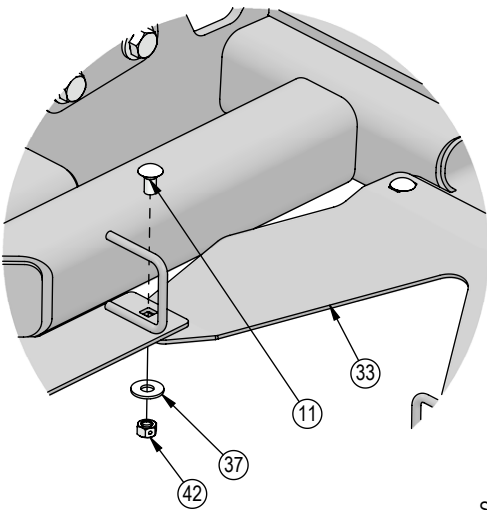

DETAIL B
SCALE 1 : 8

ITEM NO.	QTY.	PN	DESCRIPTION
20	1	NA	Grouser Dozer Metal Serial Tag
21	2	27-15588	HD Decal
21	1	27-18882	Not For Pushing or Pulling Decal
23	1	27-40962	Warning Prop 65 Decal
24	1	27-18887	Grouser Name Plate Decal
25	2	27-40983	Ag Pro Decal
26	3	44-18141	Shim, Front 1/8"
27	3	44-18142	Shim, Rear 1/8"
28	3	44-18143	Shim, Front 1/16"
29	3	44-18144	Shim, Rear 1/16"
30	2	44-18147	Plate, Front Nut
31	2	44-18245	Rear Nut Plate Weldment
32	1	44-40504	Plate, Cover
33	1	44-41875	Plate, Hose Guard
34	1	54-43929	Undercarriage Weld
35	104	57-19088	3/4" Hardened HD Flat Washer
36	2	57-20742	3/8" Flat Washer
37	9	57-20744	1/2" Flat Washer
38	12	57-20757	3/4" Flat Washer - 1-1/2" OD
39	20	57-20758	7/8" SAE Hardened Flat Washer - 1-3/4" OD
40	32	70-20597	3/4" Hex Nut Gr 8 NC
41	4	70-20598	7/8" Hex Nut Gr 8 NC
42	5	70-20604	1/2" Center Lock Hex Nut
43	6	70-20607	3/4" Center Lock Hex Nut
44	2	70-20622	3/8" Flange Hex Nut Gr 5 NC
45	8	70-20627	3/4" Flange Hex Nut

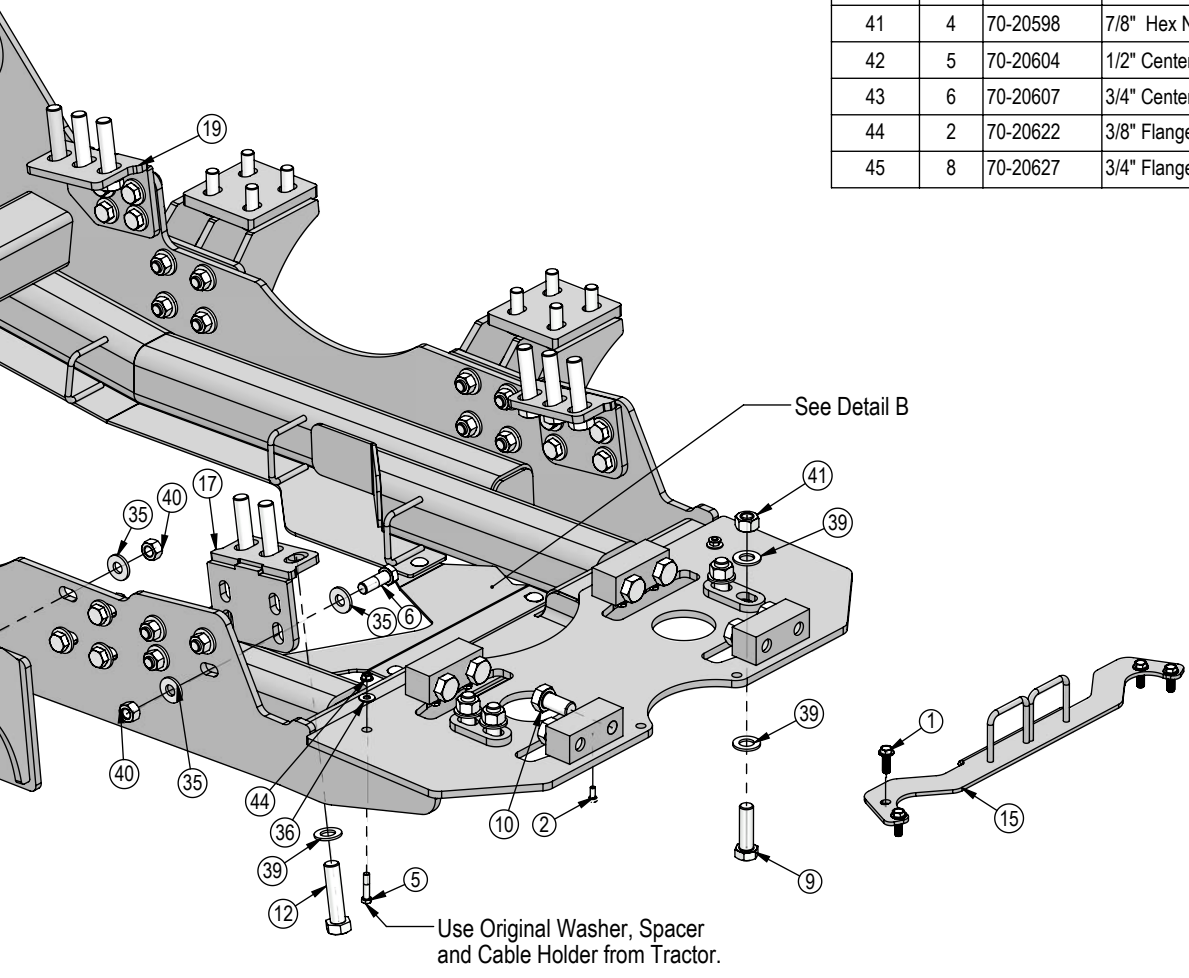

ITEM NO	QTY.	PART NO.	DESCRIPTION
46*	2	59-16899-8	8" Heavy Duty Velcro Strap
47*	1	57-20791	5/16" Fender Washer

* Part not shown

DWG. NO.: 43929-A

Improvements

Grouser Products Inc. is continually striving to improve its products. We reserve the right to change prices, specification, or equipment at any time without notice. We also reserve the right to make improvements or changes when it becomes practical and possible to do so without incurring any obligation to make changes or additions to the equipment sold previously.

Warranty

Grouser Products warrants to the original purchaser of each item that the product be free from defects in material and workmanship under normal use and service for a period of **two (2) years for Agriculture Series Blades and one (1) year for Heavy Duty Series from date of original retail delivery.**

The obligation of the consumer under this warranty:

1. To read the operators manual and to operate, lubricate, maintain and store equipment in accordance with the instructions listed in the operators manual.
2. To inspect equipment and if any part needs repair or replacement when continued use would cause damage or wear to other parts or safety.
3. All equipment or parts claimed to be defective in material or workmanship must be made available for inspection at the place of business of a dealer authorized to handle the equipment covered by this warranty, or, upon request by Grouser Products, shipped to the Grouser Products factory in West Fargo, North Dakota.

The obligation of the dealer under this warranty:

1. Complete warranty registration form and submit within 30 days of sale.
2. Contact Grouser Products for authorization prior to performing any warranty repairs or part replacement.
3. Complete warranty request form and submit with photos and supporting documentation.

The obligation of Grouser Products under this warranty:

1. Repair or replace, any equipment or parts, in the judgment of Grouser Products to be defective in material or workmanship.
2. Grouser Products will cover the cost of parts and ground shipping at dealer invoice only.
3. Grouser Products shall have no obligation to bear the cost of labor or transportation in connection with replacement or repair of any such defective parts.

This warranty does not cover:

1. Depreciation or damage caused by normal wear, accident, improper assembly, improper adjustments.
2. Improper maintenance including lack of proper lubrication, or improper use. Including loose bolts, nuts, or fitting due to over tightening or vibration after 20 hours of operation.
3. Repairs or alterations without authorization from a Grouser Products representative.
4. Grouser Products shall have no liability if the equipment has been altered or reworked without the written authorization of Grouser Products.

Grouser Products' parts, which are furnished under this warranty and properly installed, shall be warranted to the same extent as the original parts under this warranty if, and only if, such parts are found to be defective within the original warranty period covering the original equipment.

NO EMPLOYEE OR REPRESENTATIVE OF GROUSER PRODUCTS IS AUTHORIZED TO CHANGE THE WARRANTY IN ANY WAY OR GRANT ANY OTHER WARRANTY.

Contact Us

As always, if you have any questions about your system or other products made by Grouser, feel free to contact us.



755 2nd Ave NW - West Fargo, ND 58078
+1 701-282-7710 | info@grouser.com
www.grouser.com