

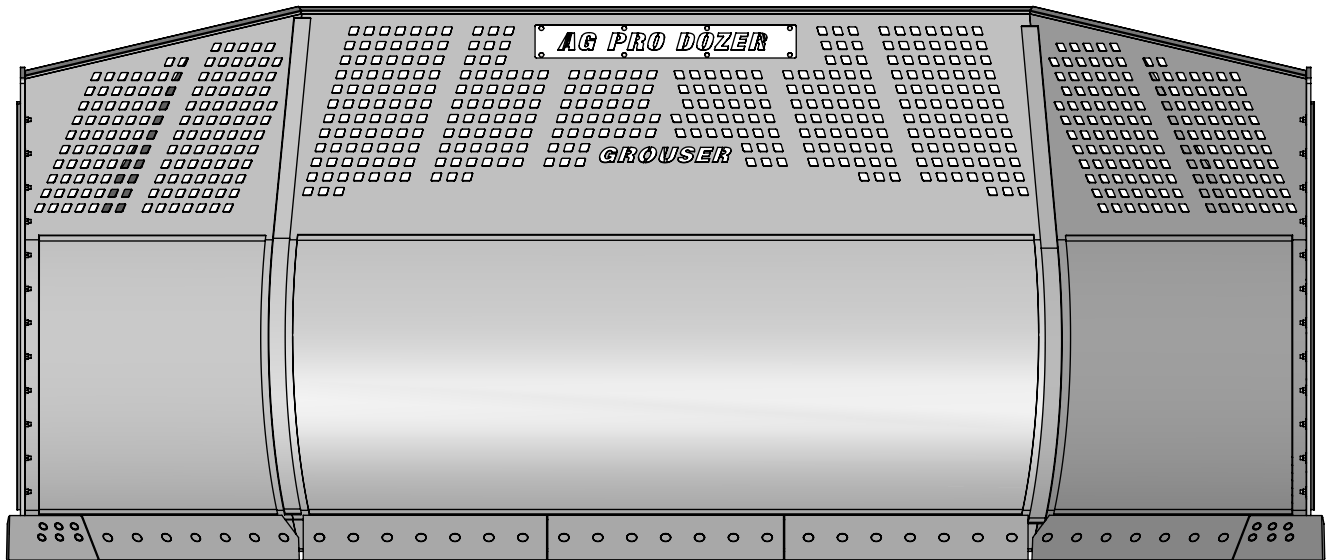

HD 19' U-Blade

Owner's Manual & Parts Book



Grouser Products
 755 2nd Ave NW - West Fargo, ND 58078
Phone: 1-800-747-6182
Fax: 1-701-282-8131
E-mail: grouser@grouser.com
Website: www.grouser.com

Purchase Date
Serial Number
Model Number
Tractor Model
Dealer

Description	Page
Welcome To The Owner_____	2
Safety Precautions, Torque Specifications & Pre-Installation _____	3
Decals_____	4
Maintenance & Lubrication_____	5
Connecting and Disconnecting _____	6
Tilt Plate Adjustment _____	6
Complete Blade Assembly_____	7
Lift System_____	8
Tractor Side Hydraulics _____	9-11
Initial Startup_____	9
Ag Pro 19' U-Blade _____	12-13
No Angle - Hydraulic Tilt System _____	14-15
Hydraulic Multi-Coupler Maintenance _____	16-17
Hydraulic Schematics _____	18
Notes _____	19
Contact Us, Improvements, & Warranty _____	20

Thank you for your recent purchase of a Grouser 19' U-Blade. Welcome to the family of satisfied Grouser blade owners. Grouser Products is committed to offering quality products to help professionals in their daily jobs. We are also committed to providing you the highest level of customer satisfaction possible. Again, thank you for your patronage. We look forward to serving you.

This manual contains information concerning the operation, adjustment, safety and maintenance of the 19' U-Blade. You have purchased a dependable, long lasting piece of equipment. You can expect to receive long lasting performance and long service built into our products with proper care and operation. Please have all operators read and understand this manual carefully. Keep the manual available for reference. If, for any reason, you have questions or comments, we would be happy to hear from you. Call our number, 701-282-7710, or send us an e-mail at info@grouser.com. You can expect us to respond to your e-mail in a timely manner.

NAHT	No Angle - Hydraulic Tilt
------	---------------------------

--	--

A careful operator is the best operator. Most accidents can be avoided by observing certain precautions. To help prevent accidents, read and take the following precautions before operating this equipment. In addition, please follow all safety and operational instructions of your tractor manufacturer.

The 19' U-Blade:

1. The 19' U-Blade should be operated only by those who are responsible and instructed to do so.
2. Read the owner's manual carefully before using this equipment. Lack of operating knowledge can lead to accidents.
3. Keep the 19' U-Blade maintained in reliable and satisfactory condition to ensure your safety.
4. Make sure the area is clear of people before moving any equipment.
5. Do not modify or permit anyone else to modify or alter the equipment and its components without first consulting Grouser Products.
6. Lower the blade to the ground when not in use.

Servicing the 19' U-Blade:

1. Read and follow all safety instructions provided by the tractor manufacturer.
2. Always use proper personal safety gear when performing maintenance on equipment.
3. Before servicing, relieve hydraulic pressure, stop engine and fully engage parking brake.
4. Escaping hydraulic fluid under pressure can penetrate skin causing serious injury. If fluid is injected into skin, obtain medical attention immediately.
 - DO NOT use your hand to check for leaks. Use a piece of cardboard or paper to search for leaks.
 - Stop the engine and relieve pressure before connecting or disconnecting lines.
 - Tighten all connections before starting the engine or pressurizing lines.

Storing the 19' U-Blade:

1. Thoroughly clean the 19' U-Blade before storage. Use paint where necessary to prevent rust.
2. Check the 19' U-Blade for worn or damaged parts. Install new parts as required.
3. Lubricate all pins and joints.

Tighten all bolts to the values listed below unless otherwise noted. Refer to the parts lists for proper length and grade of the bolts.

Size	Torque - Dry (ft-lbs)			
	SAE Grade 5		SAE Grade 8	
	UNC	UNF	UNC	UNF
5/16	17	19	24	27
3/8	30	35	45	50
7/16	50	55	70	80
1/2	75	85	110	120
9/16	110	120	150	170
5/8	150	170	210	240
3/4	260	300	380	420
7/8	430	470	600	670
1	640	720	910	1020

Size	Torque - Dry (ft-lbs)
	Grade 10.9
M18 x 2.50	284
M20 x 2.50	401
M22 x 2.50	547
M24 x 3.00	694

Unstrap and remove the lift frame, hoses, top arms, and any boxes of hardware from the undercarriage. If any components are missing, call Grouser.

Install undercarriage per the tractor specific mounting instructions.

HD 19U

PN: 27-41686



WARNING
PINCH AREA
 Keep away
 Failure to comply could result in death or serious injury.

27-2409

PN: 27-2409
Left and Right Side

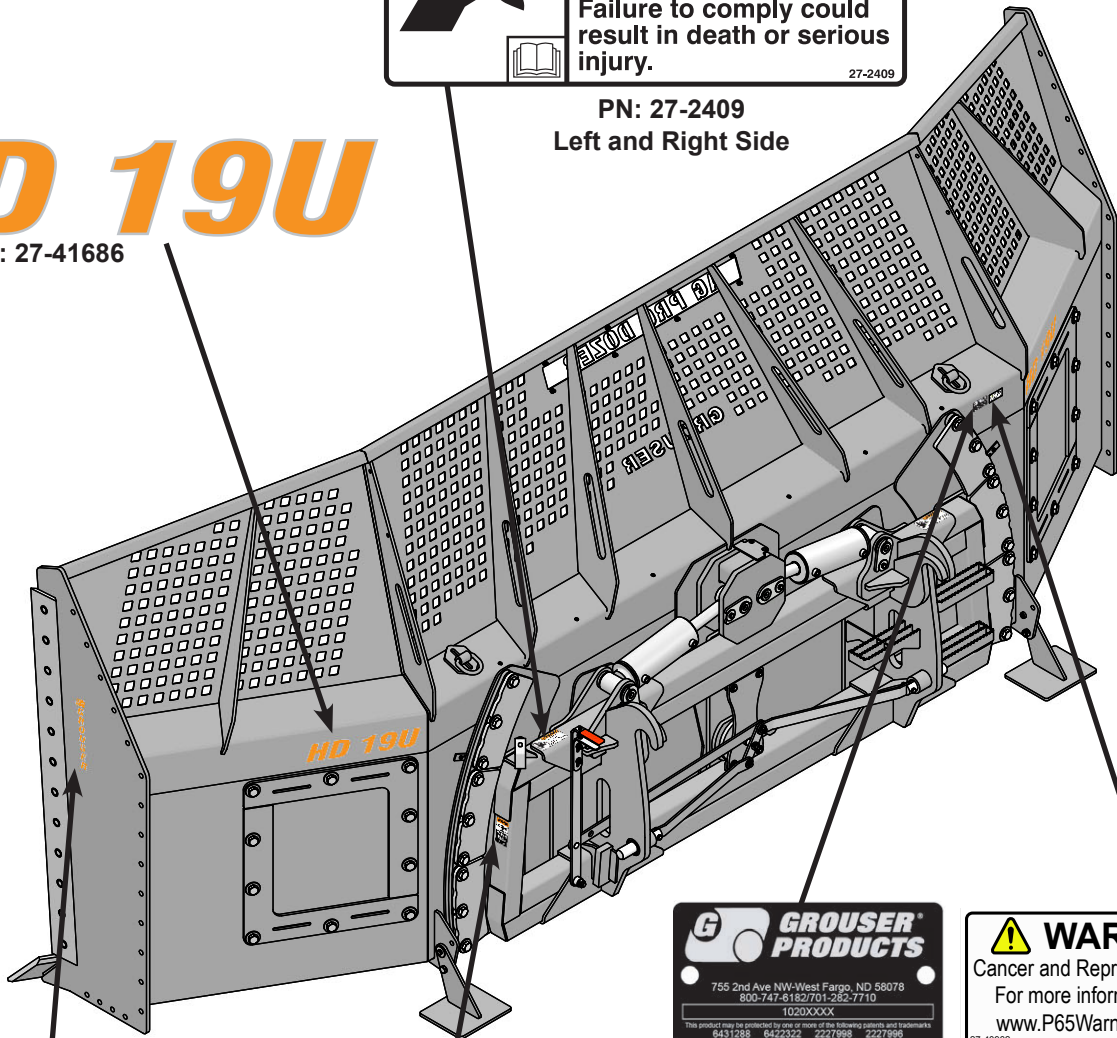

G GROUSER PRODUCTS
 755 2nd Ave NW-West Fargo, ND 58078
 800-747-6182/701-282-7710
 1020XXXX
This product may be protected by one or more of the following patents and trademarks:
 6837788 6827924 6827925 6827926
 6827788 6807041 6962350 7131652



WARNING
 Cancer and Reproductive Harm
 For more information go to
www.P65Warnings.ca.gov

27-40962

PN: 27-40962

G GROUSER

PN: 27-9505
Left and Right Side



WARNING
PINCH POINT
 AVOID INJURY FROM
 FRAME PIVOT AND STOPS.
 • Keep hands and feet away.

27-9503

PN: 27-9503
Left and Right Side

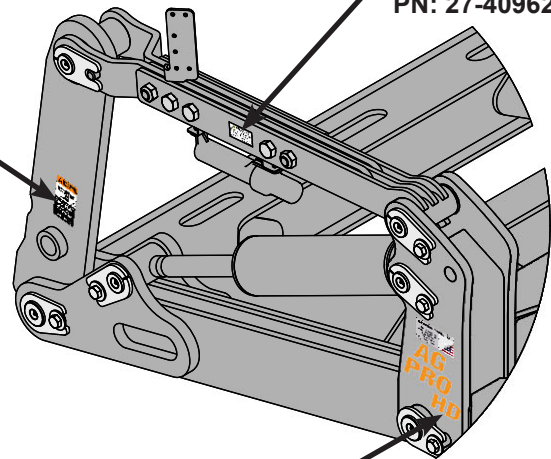

HD

PN: 27-15588
Left and Right Side

Due to the harsh environment this equipment operates in, the following tasks should be performed every 10 hours or less.

- Inspect all equipment before operation for existing or potential damage.
- Lubricate all joints with high quality grease. See below for grease locations.
- Inspect all bolts, and tighten any loose bolts to torque specifications on page 3.
- Check replaceable cutting edge for wear ensuring there is enough material to prevent permanent damage to the 19' U-Blade. For cutting edge information, see pages 12-13 .
- Check hydraulic cylinders and hoses for damage or leaks. For replacement parts, see hydraulic pages 8, 10-11 and 14-15.
- Make sure all non-rotating pins are secured properly.
- Inspect all decals and order replacement decals from your dealer if any are damaged or worn.
- For multi-coupler maintenance, see pages 16-17.
- Inspect all tilt-ways for wear. See page 6 for tilt plate adjustment.
- Replace parts with original parts only.

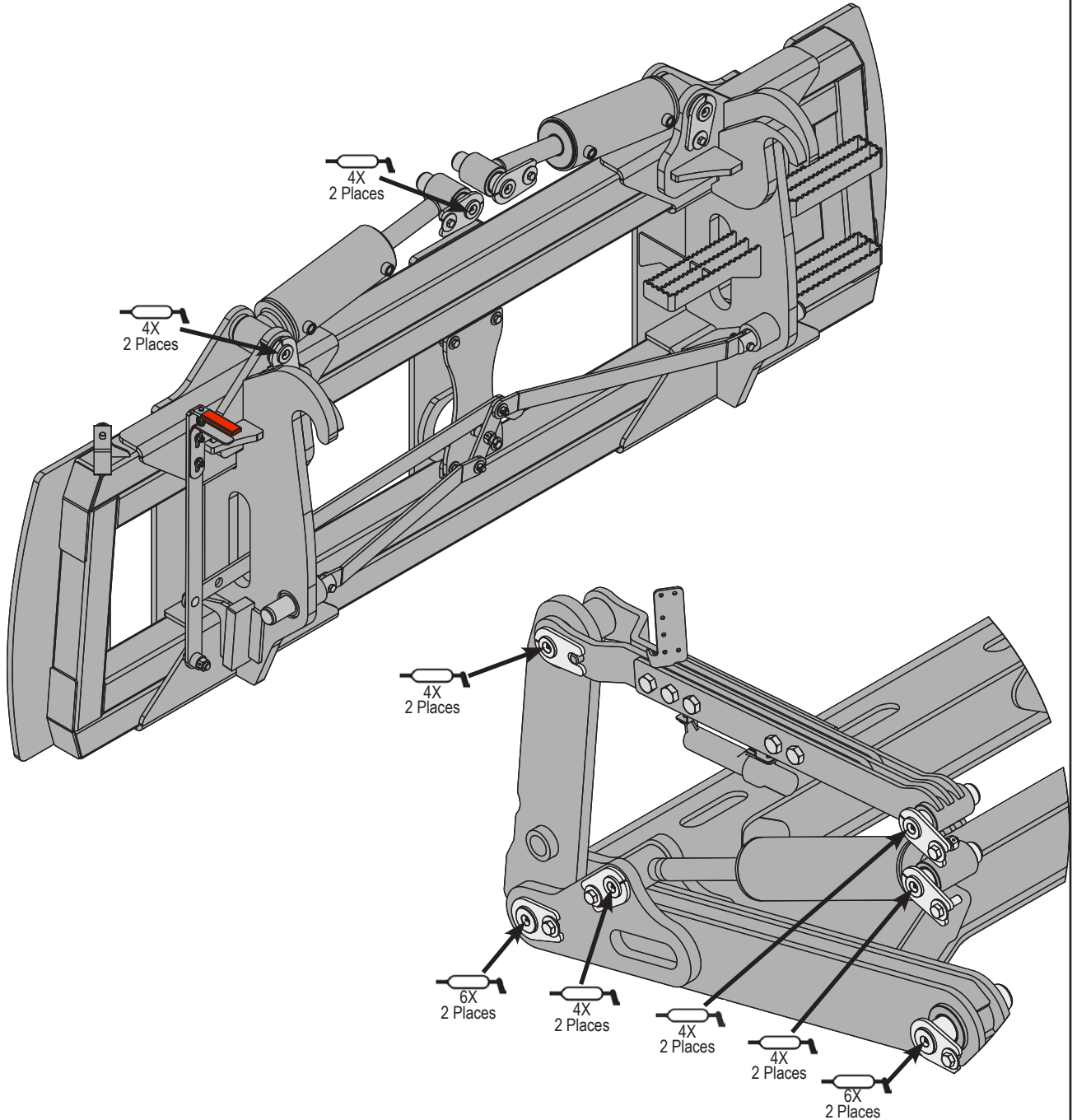

To Connect:

Note: If necessary, use a spotter to help center the blade on the lift system.

1. If necessary, lift the locking latch and pull the quick attach lock handle on the left side of the lift system to open the quick attach system. Refer to Page #14-15 for further clarification on the quick attach system.
2. Drive the tractor forward slowly until the top edge of the male quick attach is under the top hook of the female quick attach on the blade assembly.
3. Raise the lift system until the male quick attach engages the female hook. If both sides don't fully engage, reposition. Continue to raise the lift system until the blade is off the ground and the female quick attaches are against the front of the male quick attaches.
4. Shut off the tractor engine and set the parking brake.
5. Push the quick attach lock handle to engage the quick attach pins and lift the locking latch to lock the handle in place.
6. Clean and connect hydraulic multi-coupler on the top arm. Refer to Pages 16-17 for cleaning and connecting information.
7. If initial startup, refer to Page 9 before operating any function of the blade.

To Disconnect:

1. Lower the blade until the cutting edge is off the ground a few inches.
2. Shut off the tractor engine and set the parking brake.
3. Unhook the multi-coupler on the top arm.
4. Remove the multi-coupler covers from the parking stations on the blade assembly and install on the multi-couplers on the top arms.
5. Plug the blade side multi-couplers into the parking station.
6. Lift the locking latch and pull the quick attach lock handle to disengage the quick attach pins.
7. Start tractor, disengage the parking brake, and lower the blade until cutting edge is on the ground.
8. Continue to slowly lower the lift system to disengage the blade.
9. Slowly back away from the blade. When lift system is clear from the blade, raise the lift system.
10. Shut off the tractor engine and set the parking brake.

Preferred Method:

1. The preferred blade position for adjusting tilt plates is laying face down on blocks.
2. Remove bolts and tilt plates from right side.
3. Add or remove washers as needed to adjust tilt-way clearance to 1/16" - 1/8".
4. Reinstall bolts on right tilt plates.
5. Follow Steps #2-4 for left tilt plates.
6. Once tilt-way clearance is set, torque bolts to 640 ft-lbs.

Non-Preferred Method:

Note: Do not remove all of the bolts at the same time if the blade is not laying face down.

1. The non-preferred blade position for adjusting the tilt plates is the blade in the upright position.
2. Remove 3 bolts from top right tilt plate and bottom left tilt plate..
3. Add or remove washers as needed to adjust tilt-way clearance to 1/16" - 1/8".
4. Reinstall bolts in top right tilt plate and bottom left tilt plate.
5. Follow Steps #2-4 for bottom right tilt plate and top left tilt plate and then for right and left center tilt plates.
6. Once tilt-way clearance is set, torque bolts to 640 ft-lbs.

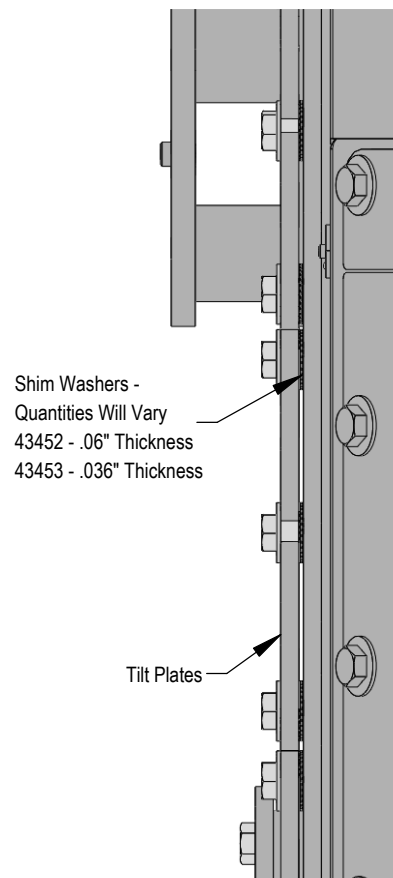
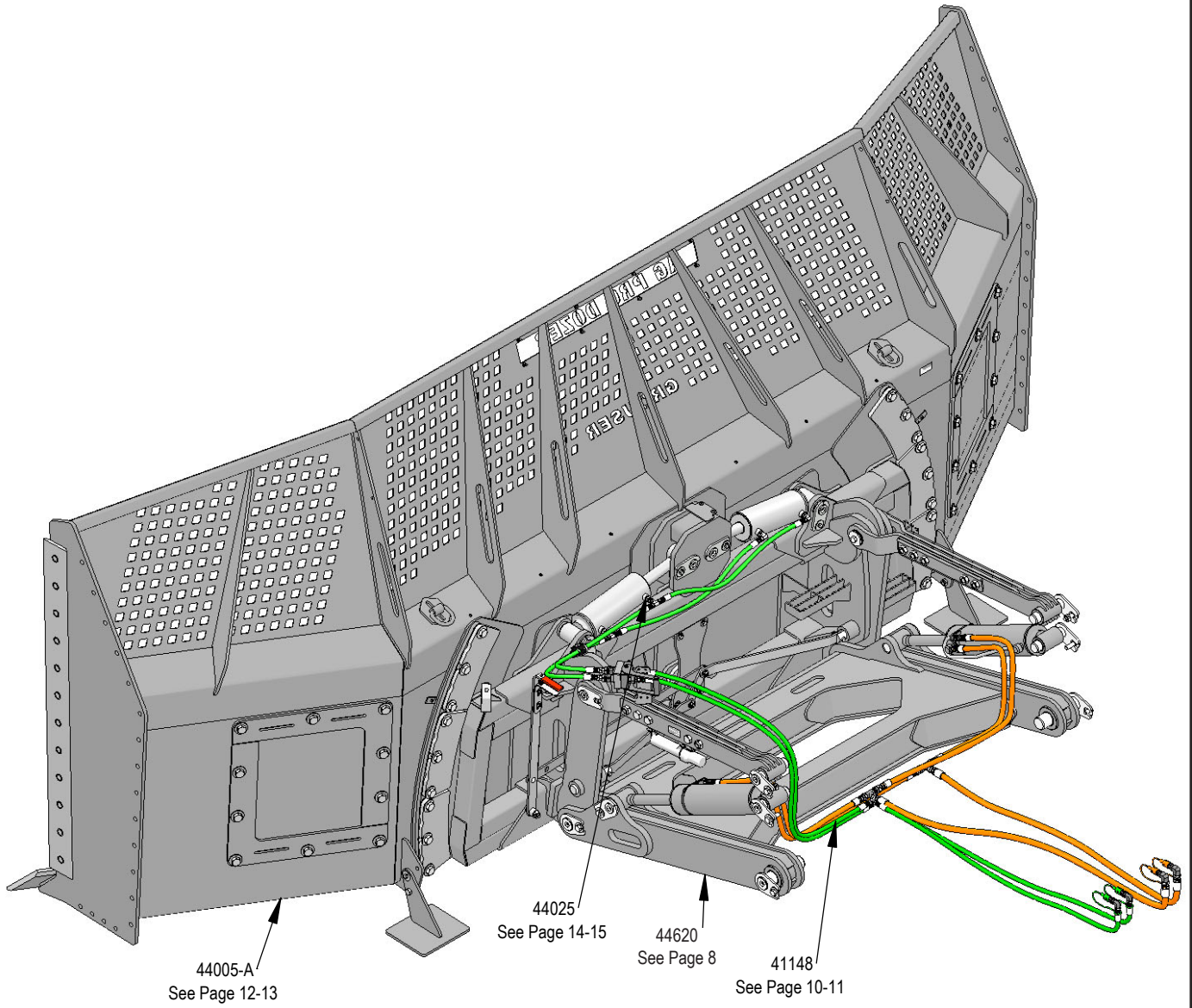
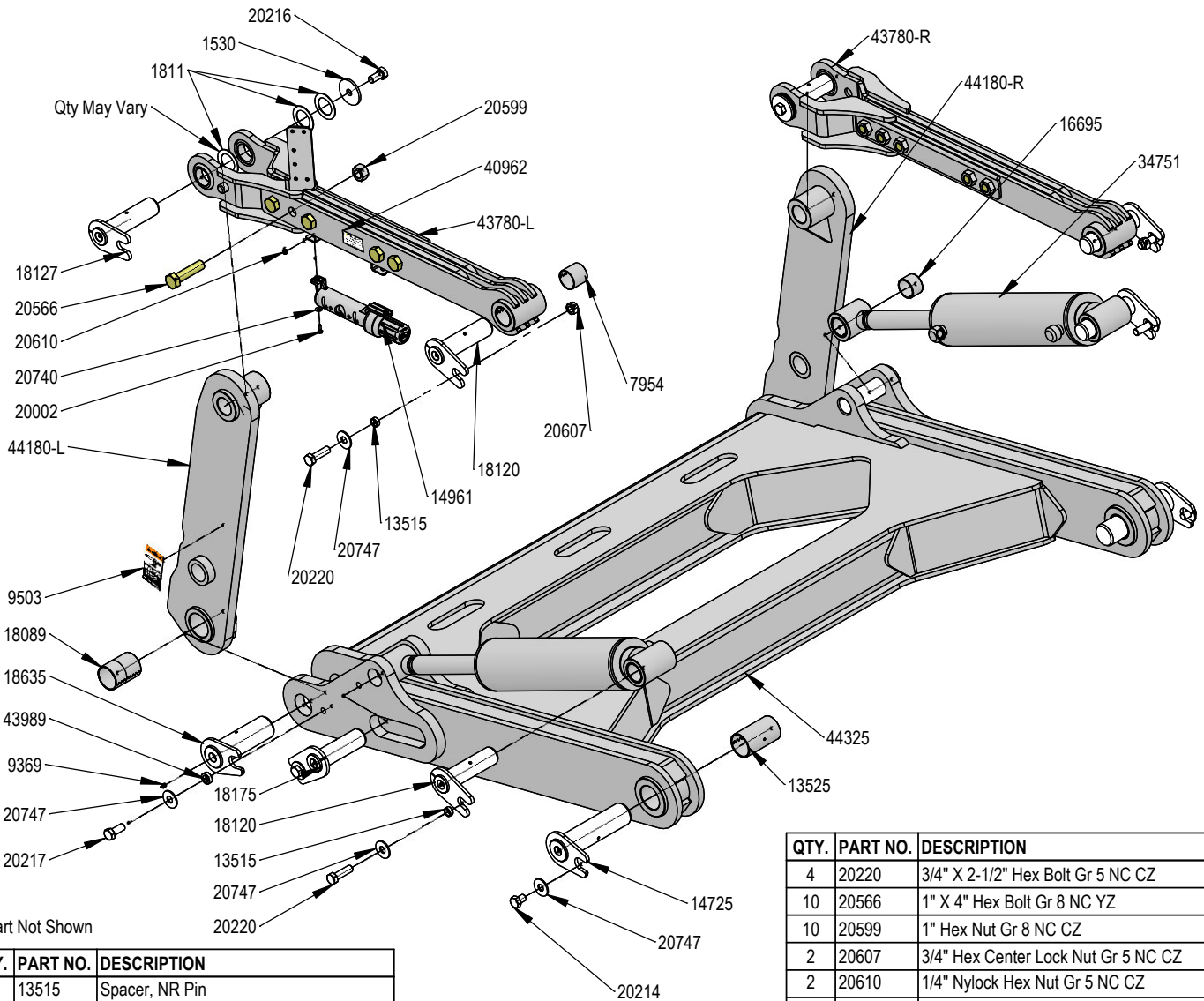

Figure 1



Some assembly of Lift System components is necessary. Follow the steps listed below. See diagram below for the correct hardware and orientation of parts.

1. Remove all pins and fasteners on each side of the undercarriage and set aside for later installation.
2. Position the lift frame between the two plates on both sides of the undercarriage and align to the bottom holes.
3. Insert pins and hardware to attach the lift frame, the base end of the lift cylinders, and the top arms to the undercarriage.
4. Insert pins and hardware to attach the male quick attaches to the lift frame, and to the top arms. Use 2" washers as shims to keep top arm pins tight and in place. Only use as many as needed until pin is tight.
5. Torque all fasteners according to the specifications on Page 3.



* Part Not Shown

QTY.	PART NO.	DESCRIPTION
6	13515	Spacer, NR Pin
2	13525	2.75 x 2.50 x 4.75 Spring Bushing
2	14725	Lift Frame / UC Pin
1	14961	Manual Canister Small
2	1530	3/4" x 3".00 x .25" HD Washer CZ
8	16695	2.25 x 2.00 x 1.50 Spring Bushing
2	18089	2.75 x 2.50 x 3.75 Spring Bushing
6	1811	2" Washer
4	18120	Top Pin Weld
2	18127	Top Arm Pin Weld
2	18175	Lift Cyl Pin Weld
2	18635	Ag Pro Plus QA Pin
2	20002	1/4" X 3/4" Hex Bolt Gr 5 NC CZ
2	20214	3/4" X 1" Hex Bolt Gr 5 NC CZ
2	20216	3/4" X 1-1/2" Hex Bolt Gr 5 NC CZ
4	20217	3/4" X 1 3/4" Hex Bolt Gr 5 NC CZ

Note: The cylinder part number is stamped on the base end of the cylinder opposite of the hydraulic ports.

QTY.	PART NO.	DESCRIPTION
4	20220	3/4" X 2-1/2" Hex Bolt Gr 5 NC CZ
10	20566	1" X 4" Hex Bolt Gr 8 NC YZ
10	20599	1" Hex Nut Gr 8 NC CZ
2	20607	3/4" Hex Center Lock Nut Gr 5 NC CZ
2	20610	1/4" Nylock Hex Nut Gr 5 NC CZ
2	20740	1/4" Flat Washer CZ
10	20747	3/4" Flat Washer CZ
2	34751	5 x 18 Hydraulic Cylinder
2	40962	Warning Prop 65 Decal
1	43780-L	Ag Pro Plus Manual Pitch Top Arm Assy
1	43780-R	Ag Pro Plus Manual Pitch Top Arm Assy
2	43989	.75 x 1.25 NR Pin Bushing
1	44180-L	HD Male SS QA
1	44180-R	HD Male SS QA
1	44325	HD Lift Frame
4	7954	2.25 x 2.00 x 2.00 Spring Bushing
12	9369	Straight 1/8" NPT Grease Zerk
2	9503	Pinch Decal (Foot)

No. On Cylinder	Part No.	Description	DWG. NO.:
26	34751	Seal Kit 5" (658457) Nitrided Rod	44620

Note: Refer to Pages 10-11 for the correct hose lengths and hose location.

Note: All connections are identified by spiral bands. 2 bands are from the base end of a cylinder and 1 band is from the rod end of a cylinder. Orange = Lift and Green = Tilt.

1. Connect the lift hoses to the lift cylinders.
2. Verify that hoses are not twisted and protected from rubbing on any sharp edges. See Pages 10-11 for proper hose routing.
3. Install the straight fittings into the multi-couplers on both top arms.
4. Identify each remaining hose at the front of the undercarriage by the colored bands on the end of the hose and connect the hose to the corresponding straight fitting on the multi-coupler. Refer to Pages 10-11 for proper hose locations.
5. Continue below for initial startup instructions.

Prior to operating the blade system, all air must be purged from the hydraulic system. Follow the steps below for each function on your blade.

Lift Function:

1. With the lift frame down and blocked, loosen the fittings on both ends of the lift cylinders.
2. Actuate the raise function to supply oil to the rod end of the cylinders.
3. When oil starts to flow from the fittings, stop oil flow, and tighten the fitting on the rod end of the lift cylinders.
4. Continue to flow oil until the system is fully raised and then block the lift frame.
5. Actuate the function in the opposite direction to supply oil to the base end of the lift cylinders.
6. When all air is removed from the lift system, stop oil flow and tighten the fittings on the base end of the lift cylinders.
7. Raise lift system and remove blocks. Cycle up and down 5 more times.
8. Check tractor oil level and fill if necessary.
9. Continue with connecting the blade on Page 6.

Tilt Function:

1. Use a lift or jack to tilt the blade system until the left side is fully up, loosen the fittings on the rod and base end of both tilt cylinders.
2. Actuate the tilt function to extend the right tilt cylinder and supply oil to the base end of the right cylinder and to the rod end of the left cylinder.
3. When oil starts to flow from the fittings, stop oil flow, and tighten the fitting on the base end of the right cylinder and rod end of the left cylinder.
4. Remove the lift or jack.
5. Continue to actuate the tilt function until oil flows out of the remaining open ports.
6. Actuate the tilt function in the opposite direction.
7. When all air is removed from the tilt system, stop oil flow, and tighten the remaining fittings on the cylinders.
8. Cycle both cylinders in and out 5 more times.
9. Check tractor oil level and fill if necessary.

Run the blade through all the functions. If any function does not operate correctly, refer to corresponding section above and re-bleed. If problem still persists, call Grouser Products.

QTY.	PART NO.	DESCRIPTION
2	812525	M8-1.25 x 25mm Class 10.9 Hex Bolt CZ
1	19868	Multi-Coupling Plate - 2 Port - Fixed
2	19870	Multi-Coupling Plate - Coupler - Male
1	19871	Multi-Coupling Plate - 2 Port - Cap
4	34342	Tappet Quick Coupler Male - Poppet Style
2	3453	Pioneer Dust Cap Tilt (Green)
2	3457	Pioneer Dust Cap Lift (Orange)
2	43459	Multi-Coupling Plate - Snap Ring
2	11699-10-10	JIC Union
2	15199-8-8	JIC Union Elbow 90°
2	34032	Bulkhead Run Tee JIC
2	34040	Straight JIC x O-Ring
4	34042	Straight JIC x O-Ring
2	34051	Straight Thread Elbow 90° JIC x O-Ring
2	34059	Straight Thread Elbow 90° JIC x O-Ring
2	12932	Cylinder Saddle
2	12933	Hose Clamp (worm drive - 5.0)
9	18888-GR	-12 Green - Spiral Band
15	19494-OR	-16 Orange - Spiral Band
2	12631-0810	81" x 1/2" -8JIC/-8JIC Abrasion Resistant Hose
2	12631-3200	320" (26.7") x 1/2" -8JIC/-8JIC Abrasion Resistant Hose
2	12637-3000	300" (25") x 3/4" -12JIC/-12JIC Abrasion Resistant Hose
2	12641-0535	53.5" x 5/8" -10JIC/-12JIC Abrasion Resistant Hose
2	12641-0670	67" x 5/8" -10JIC/-12JIC Abrasion Resistant Hose
2	18240	Lift Cylinder Steel Line
2	20740	1/4" Flat Washer CZ
2	20809	1-1/16" Hex Jam Nut NF CZ
2	44309-0200	20" x 3/4" -12MJIC/-12JIC Hose

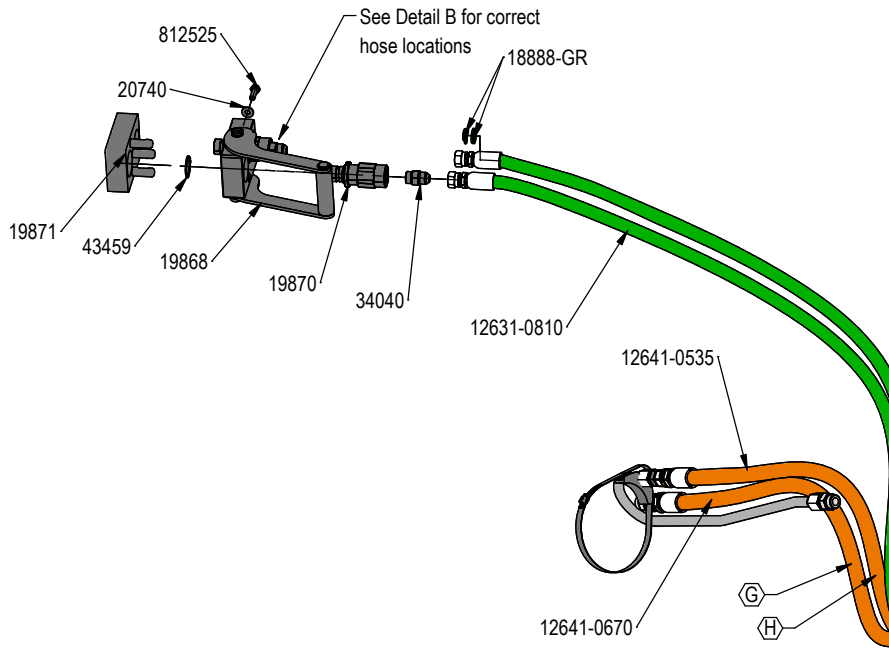

View of Left Side Hoses
From The Front

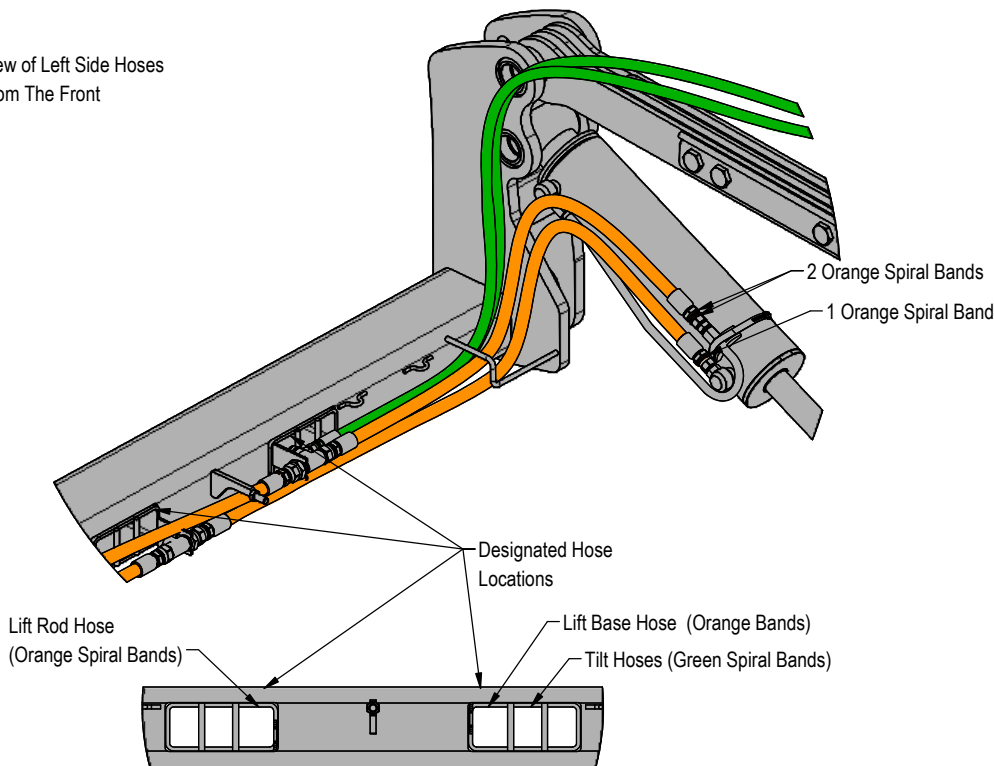

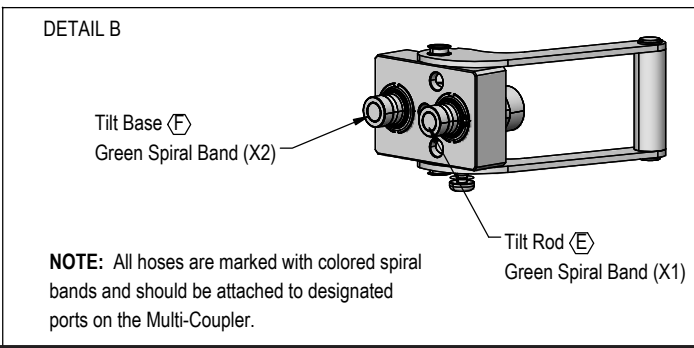
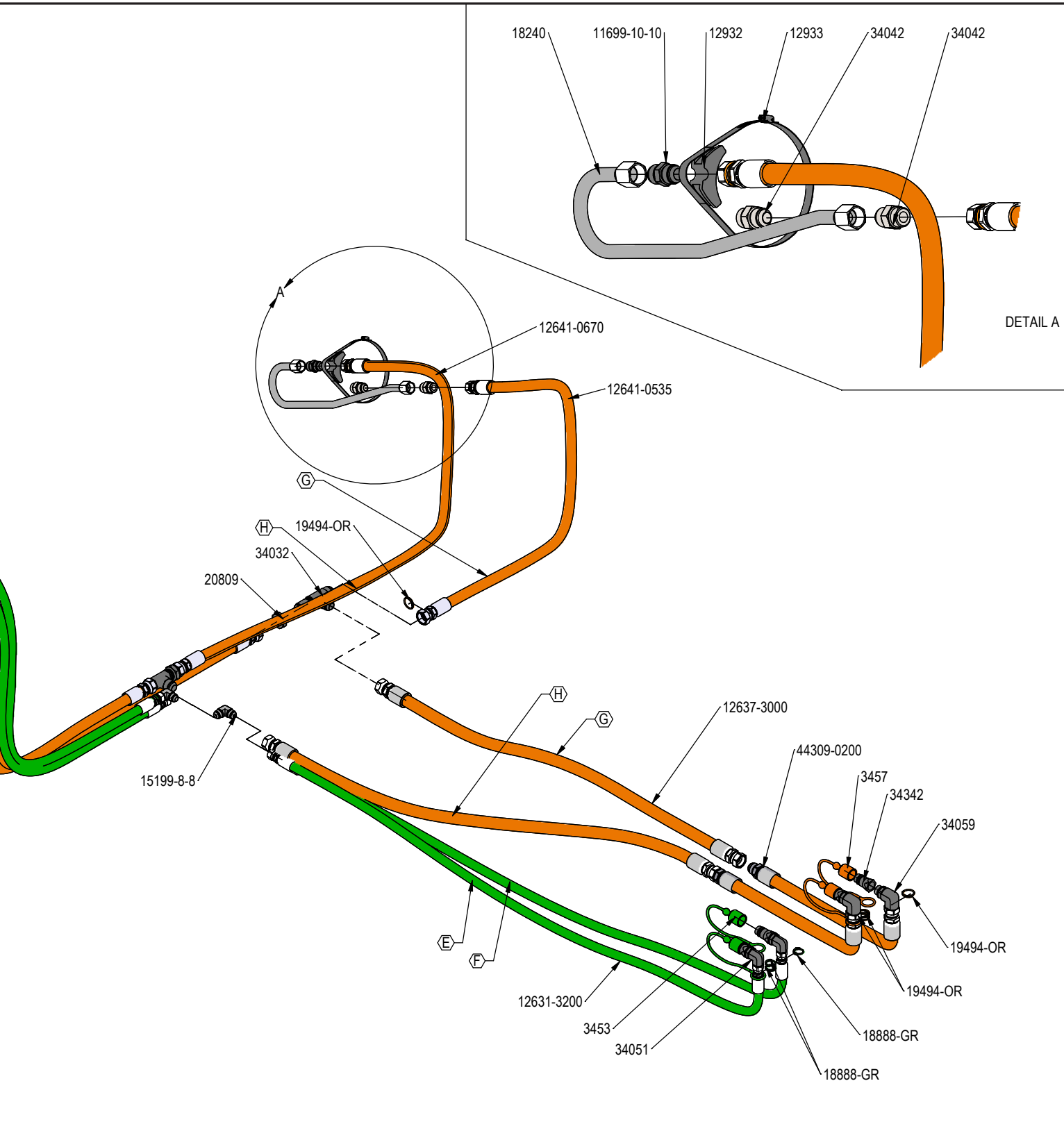

Hoses Not Drawn to Scale
Every hydraulic function from the front to the back of the system is designated by a ○ and a letter and can also be referenced on the Hydraulic Schematics on Page 18.

DWG. NO.: 41148

19' U-Blade

QTY.	PART NO.	DESCRIPTION
1	13471	1" x 10" Cutting Edge - Center
1	13472	End Bit - Right
1	13473	End Bit - Left
2	13475	1" x 10" Cutting Edge - Side
2	13476	1" x 10" Cutting Edge - Center/Sides
2	13485	Blade Stand
1	15150	Ag Pro Dozer Name Plate
2	20124	1/2" X 1" Hex Bolt Gr 5 NC CZ
2	20217	3/4" X 1 3/4" Hex Bolt Gr 5 NC CZ
20	20558	1" X 2" Hex Bolt Gr 8 NC YZ
3	20560	1" X 2-1/2" Hex Bolt Gr 8 NC YZ
2	20562	1" X 3" Hex Bolt Gr 8 NC YZ
16	20564	1" X 3-1/2" Hex Bolt Gr 8 NC YZ
2	20607	3/4" Hex Center Lock Nut Gr 5 NC CZ
8	20622	3/8" Flange Hex Nut Gr 5 NC CZ
24	20646	5/8" Hex Top Lock Nut Gr 5 NC CZ
12	20657	3/4" Hex Top Lock Nut Gr 8 NC CZ
38	20749	1" Flat Washer CZ
2	20794	1/2" Fender Washer (2.00" OD x .500" ID x .125")
24	20816-CZ	5/8" Flat Washer Grade 8 (USS) CZ
35	20999	1" Hex Top Lock Nut Gr 8 NC YZ

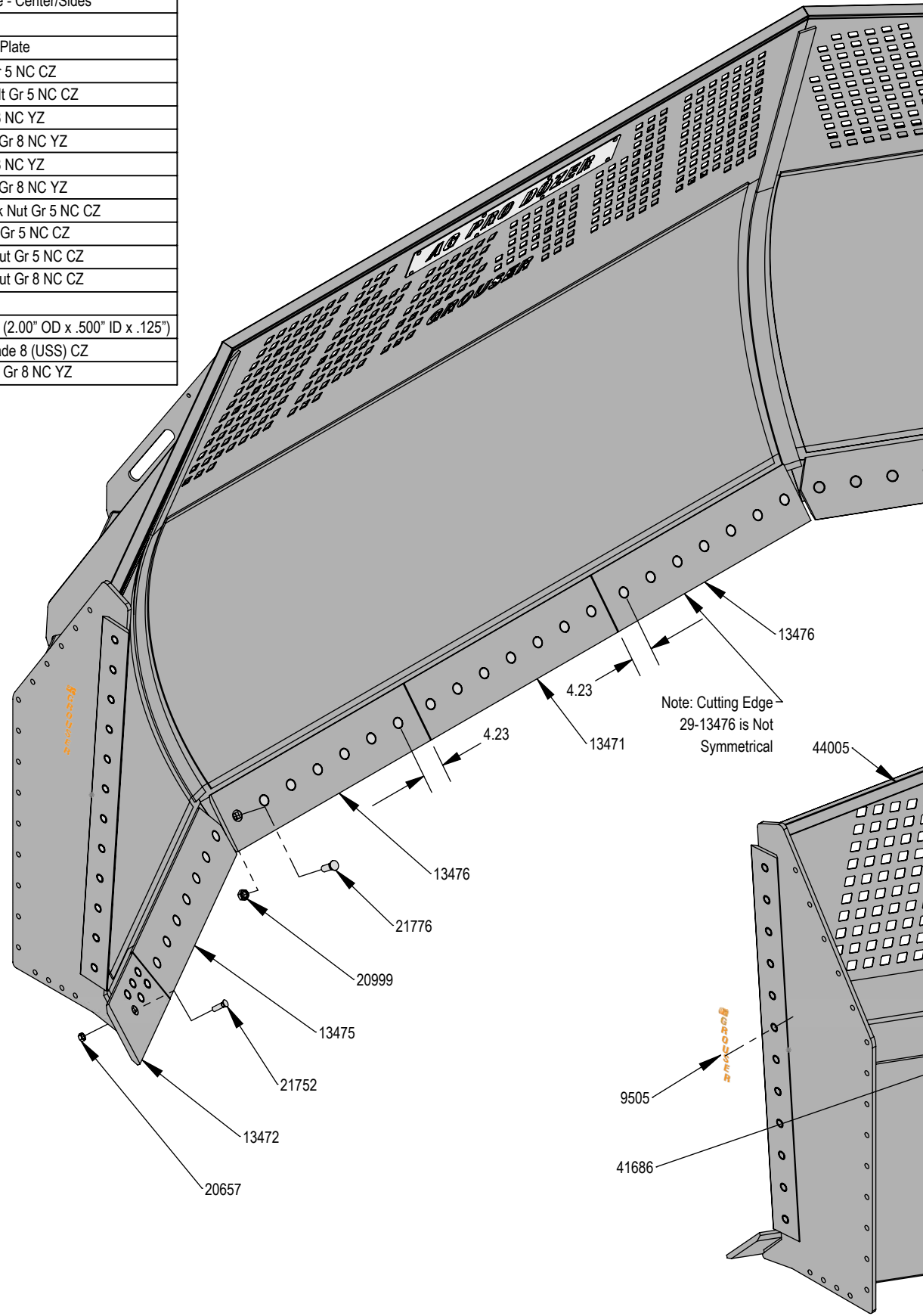

QTY.	PART NO.	DESCRIPTION
8	21064	3/8" x 1" Carriage Bolt Gr 5 NC CZ
24	21672	5/8" X 2-1/2" Plow Bolt Gr 5 NC
12	21752	3/4" X 2-1/2" Plow Bolt Gr 8 NC
35	21776	1" X 3" Plow Bolt Gr 8 NC
1	40962	Warning Prop 65 Decal
2	41686	HD 19'U Decal
36*	43452	1" Washer (.06" thickness)
36*	43453	1" Washer (.036" thickness)
1	43872	Backdrag Brace Plate
1	44005	19' U - Blade Weld
6	44024	Tilt Plate
2	7950-XX	Cutting Edge
2	9505	Grouser Vertical Decal
1	9506	Grouser Dozer Metal Serial Tag

* Quantities May Vary

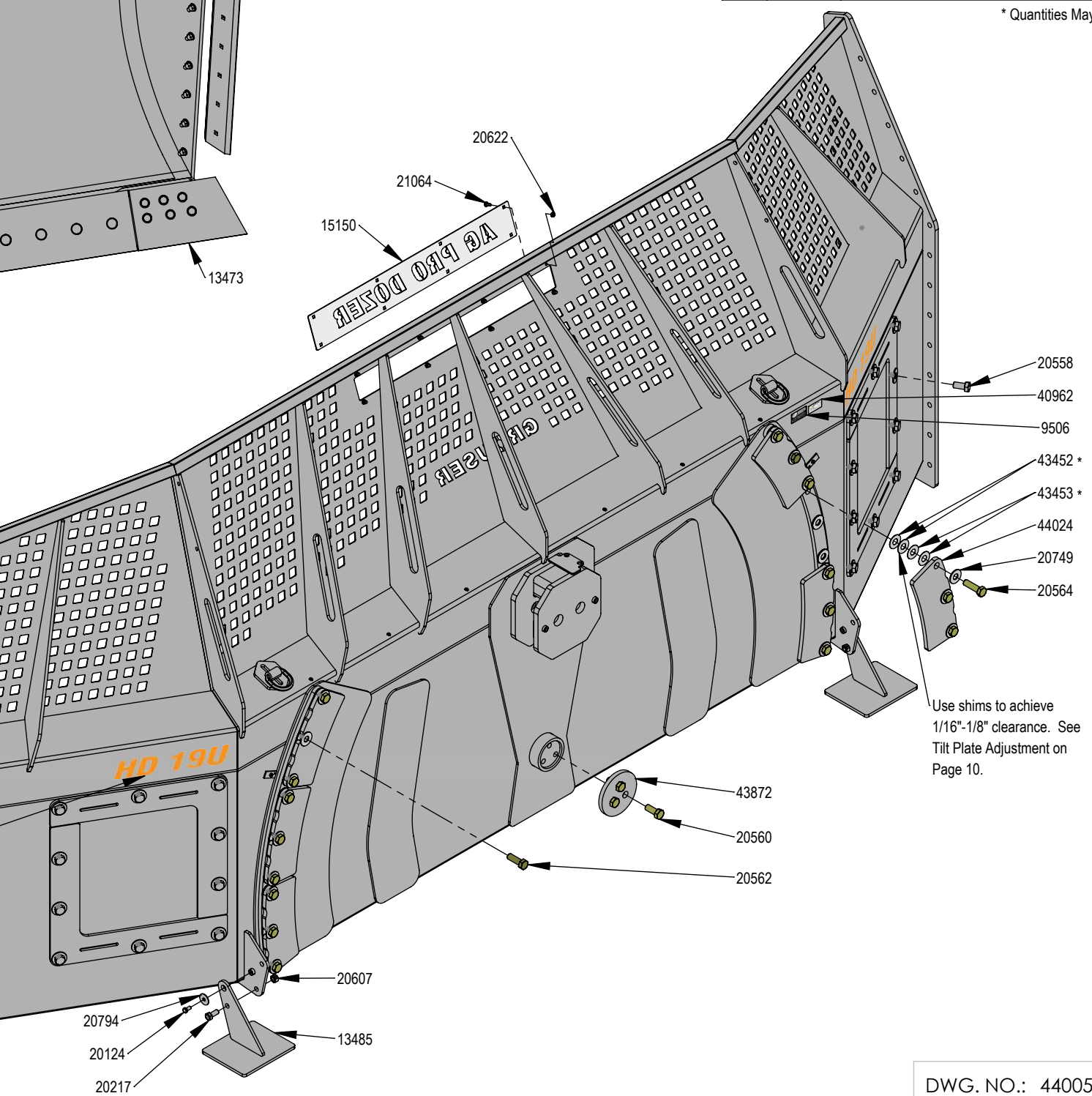
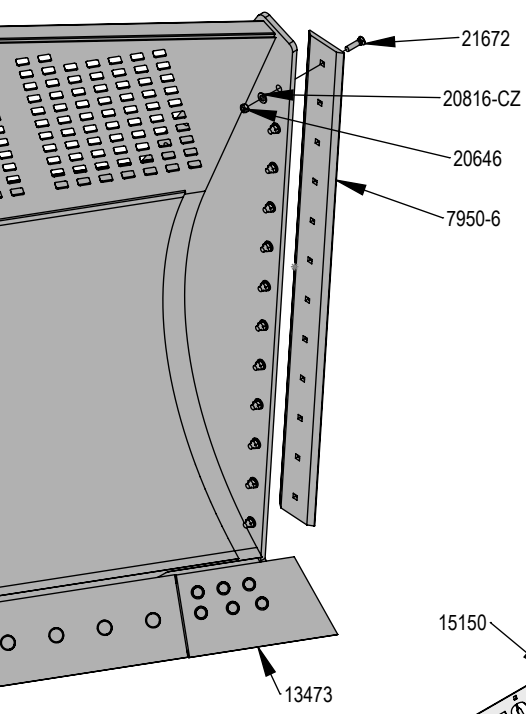

DWG. NO.: 44005-A

No Angle-Hydraulic Tilt System

QTY.	PART NO.	DESCRIPTION
1	20011	1/4" X 2-3/4" Hex Bolt Gr 5 NC CZ
1	20038	5/16" X 2" Hex Bolt Gr 5 NC CZ
4	20125	1/2" X 1-1/4" Hex Bolt Gr 5 NC CZ
4	20126	1/2" X 1-1/2" Hex Bolt Gr 5 NC CZ
1	20128	1/2" X 2" Hex Bolt Gr 5 NC CZ
2	20130	1/2" X 2-1/2" Hex Bolt Gr 5 NC CZ
2	21065	3/8" x 1-1/4" Carriage Bolt Gr 5 NC CZ
2	21126	1/2" x 1-1/2" Carriage Bolt Gr 5 NC CZ
2	812525	M8-1.25 x 25mm Class 10.9 Hex Bolt CZ
1	19311-03-P-087	Hose Clamp
1	19312-03	Twin Cover Plate
1	41984	Bracket, Center
2	40440	.378" ID x .503" OD x .375" Spacer
1	19657	Multi-Coupling Plate - 2 Port Parking Station
1	19869	Multi-Coupling Plate - 2 Port - Mobile
2	19865	Multi-Coupling Plate - Coupler - Female
2	43459	Multi-Coupling Plate - Snap Ring
2	34759	5 x 10 - Cylinder 2" ID Tube Ends
2	2409	Pinch Decal (Hand)
2	9503	Pinch Decal (Foot)
2	34040	Straight JIC x O-Ring
2	34041	Straight JIC x O-Ring
2	34051	Straight Thread Elbow 90° JIC x O-Ring
2	34080	Swivel Nut Branch Tee JIC
1	44020	Tilt Frame Weld
1	17799	Latch Spring

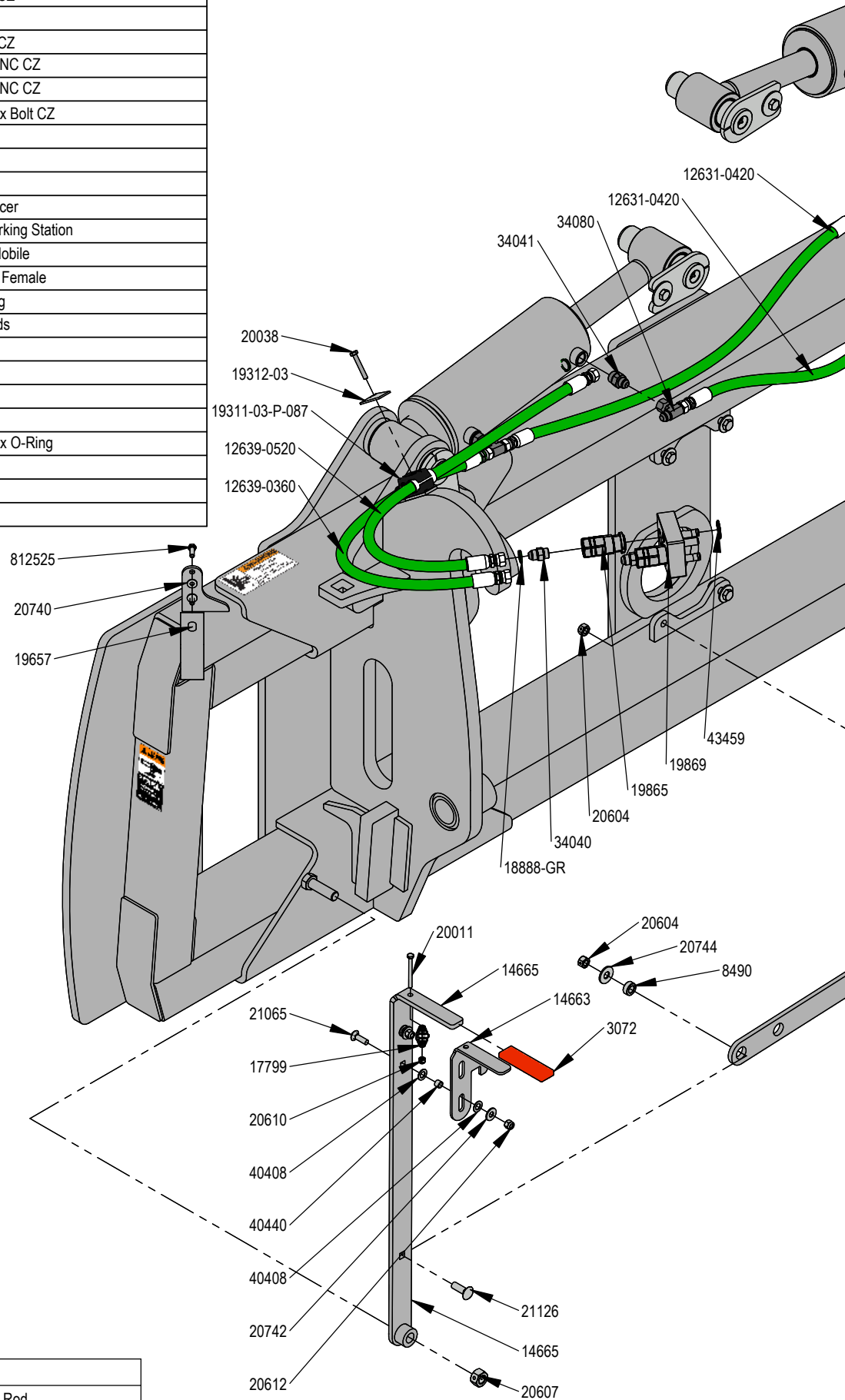

Note: The cylinder part number is stamped on the base end of the cylinder opposite of the hydraulic ports.

No. On Cylinder	Part No.	Description
26-34759	49-12277	Seal Kit 5" Nitrided Rod

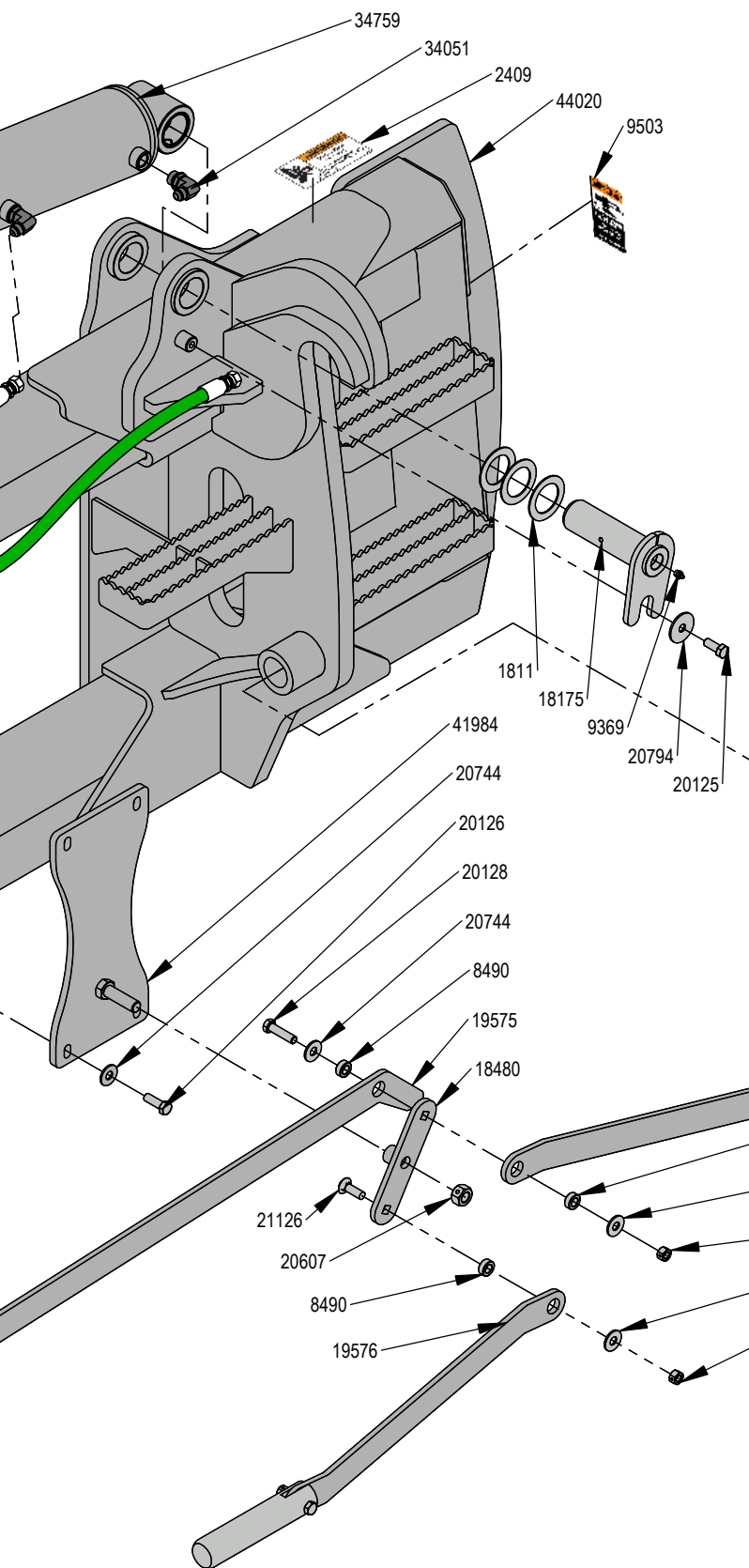

QTY.	PART NO.	DESCRIPTION
6	18888-GR	-12 Green - Spiral Band
2	12631-0420	42" x 1/2" -8JIC/-8JIC Abrasion Resistant Hose
1	12639-0360	36" x 1/2" -8JIC/-8JIC Abrasion Resistant Hose - Collar at 8.5"
1	12639-0520	52" x 1/2" -8JIC/-8JIC Abrasion Resistant Hose - Collar at 19.25"
1	14663	Latch
1	14665	Handle Weld
1	3072	Rubber Handle
4	18175	Lift Cyl Pin Weld
2	18486	Ag Pro SS QA Lock Pin
4	8490	Spacer
6	1811	2" Washer
2	20740	1/4" Flat Washer CZ
2	20742	3/8" Flat Washer CZ
8	20744	1/2" Flat Washer CZ
4	20794	1/2" Fender Washer (2.00" OD x .500" ID x .125")
4	40408	3/8" Flat Nylon Washer
4	9369	Straight 1/8" NPT Grease Zerk
9	20604	1/2" Hex Center Lock Nut Gr 5 NC CZ
2	20607	3/4" Hex Center Lock Nut Gr 5 NC CZ
1	20610	1/4" Nylock Hex Nut Gr 5 NC CZ
2	20612	3/8" Nyloc Hex Nut Gr 5 NC CZ
1	18480	Bell Crank Weld
1	19575	Plate, Link
2	19576	Link, Bell Crank To Pin

DWG. NO.: 44025

Before Each Use:

1. Disconnect the mobile half from the parking station and the cap from the fixed half.
2. Check that there is no contamination (salt, sand, dirt, etc.):
 - A. On the pins.
 - B. Inside the cam.
 - C. In the locking mechanism area.
 - D. On the face of the plates and couplings.
3. In case of contamination, remove it with a cloth and/or compressed air.
4. Check that there is still a lubricant/anti-corrosion (grease or silicone - see Note 1):
 - A. On the pins.
 - B. Inside the cam.
 - C. In the locking mechanism area.
5. Connect the mobile and fixed halves together.

Fixed Half

Mobile Half

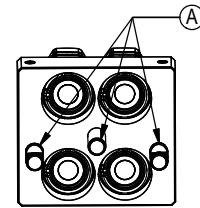
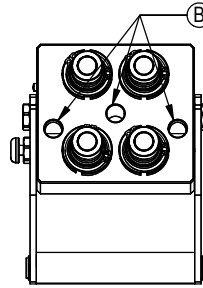
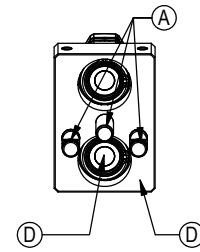
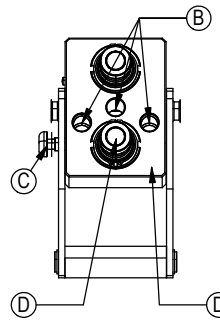

After Each Use:

1. Disconnect the mobile half from the fixed half.
2. Clean all contamination (salt, sand, dirt, etc.) from the following areas:
 - A. On the pins.
 - B. Inside the cam.
 - C. In the locking mechanism area.
 - D. On the face of the plates and couplings.

*Use a cloth or compressed air. It is advised to not use water to clean these surfaces
3. Apply a lubricant/anti-corrosion (grease or silicone - see Note 1):
 - A. On the pins.
 - B. Inside the cam.
 - C. In the locking mechanism area.
4. Connect the cap to the fixed half and the mobile half to the parking station.

Note 1:

When sand and salt are present, or the plates under go a washdown, a heavy duty silicone spray lubricant should be used to replace grease from the factory. The lubricant should help protect from corrosion without collecting dust and contaminants, and will resist washing off when exposed to water.

Recommended Lubricant Brands:

Fluid Film (Aerosol or Non-Aerosol), LPS-2 Heavy Duty Lubricant, or CRC 3-36.

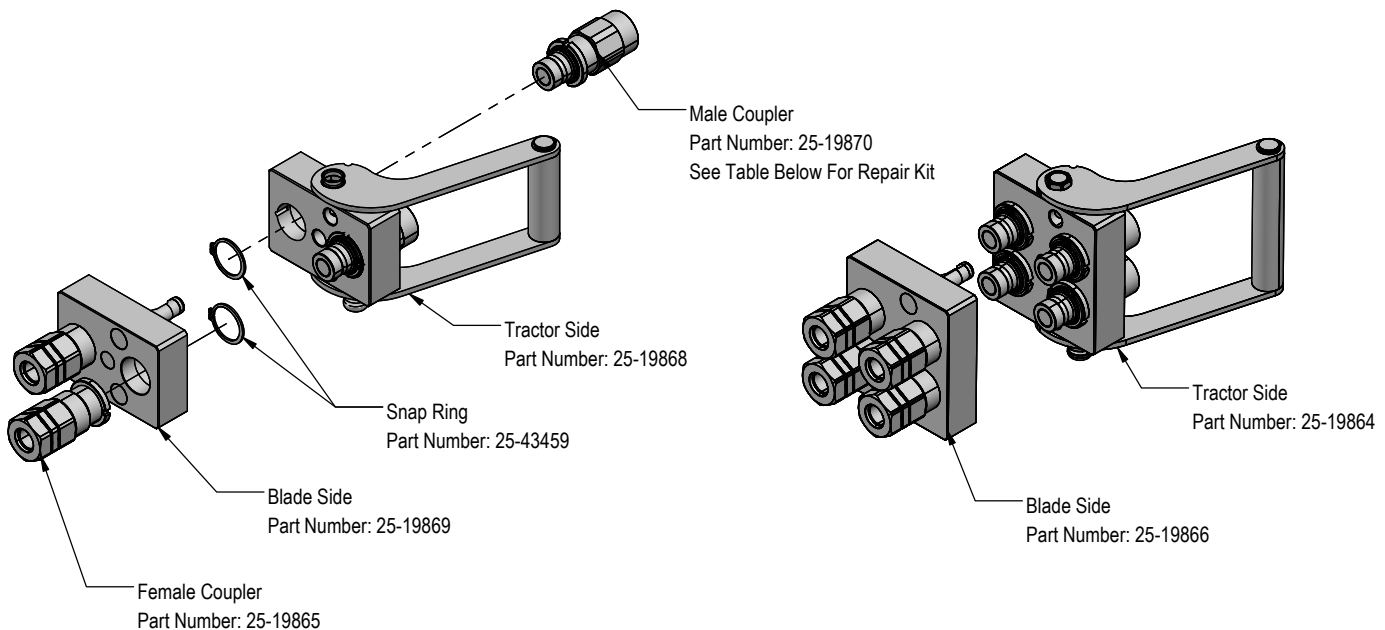

PN	Description
25-43425	Male Coupler O-Ring Repair Kit

Cleaning The Male Interface Seal:



1. Make sure the coupling is securely fastened into the plate or place in a vice.
2. Using a blunt, non-marring tool, depress the valve face until the seal is exposed. Insert a bent metal wire between the valve face and the body of the coupling. Use caution not to damage or scratch the seal when inserting the wire.
3. Inspect the seal and interior surfaces for contamination.
4. In case of contamination, carefully wipe surfaces with a soft cloth, or use compressed air to blow the contamination out. Do Not press hard on the seal as contamination can scratch the seal surface.
5. Using a non-marring tool, depress the valve face and remove the metal wire. Release the valve to the flush position.

Cleaning The Female Bushing:



1. Make sure the coupling is securely fastened into the plate or place in a vice.
2. Using a non-marring tool, depress the outer ring to expose the bushing. There is no need to expose the valve seal, so stop pressing before the valve is opened.
3. Inspect the interior body and bushing surfaces for contamination.
4. In case of contamination, carefully wipe surfaces with a soft cloth, or use compressed air to blow the contamination out.
5. Release the outer ring so that it returns to the flush position.

MALE FAP - REPAIR KIT INSTRUCTIONS

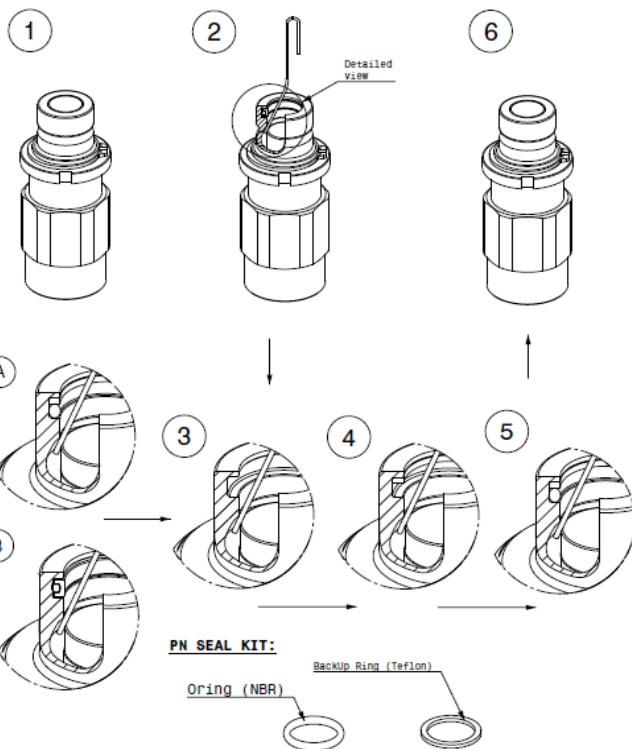

DISASSEMBLING STEPS (see figures)

1. Place the coupling in a vice.
2. Bend positioning clip as shown. Using a blunt, non marring object, depress valve face until seals are exposed. Insert the positioning clip between valve face and body, captivating the valve face.
3. Using an O-ring pick or similar device, remove the seal from retaining groove. Clean properly the retaining groove with a clean cloth.

Note: Some M FAP are originally assembled with different seal technologies (see figures A and B) but both used O-ring and backUp ring as replacement kit.

ASSEMBLING STEPS (see figures)

4. Insert the backup ring (4) in the seat and even with the use of a non sharpen tool. Place the BackUp ring on the superior shoulder of the seat in order to leave space for the O-ring (see figure 4).
5. Lubricate the O-ring with a fluid compatible with the seals compound. **Warning: using non compatible fluid would compromise the efficiency of the coupling.**
6. Push the piston with a blunt, non marring tool and take the metal clip out. Release the piston.

FUNCTIONING CHECK

Assemble the male coupling with the female in order to check the functioning and check for leaks.

BY REPLACING THE SEALS, YOU REMOVE THE WARRANTY AND BECOME RESPONSIBLE FOR THE SAFETY AND THE EFFICIENCY OF THE COUPLING!

Colored Lines = Quantity of Colored Spiral Bands

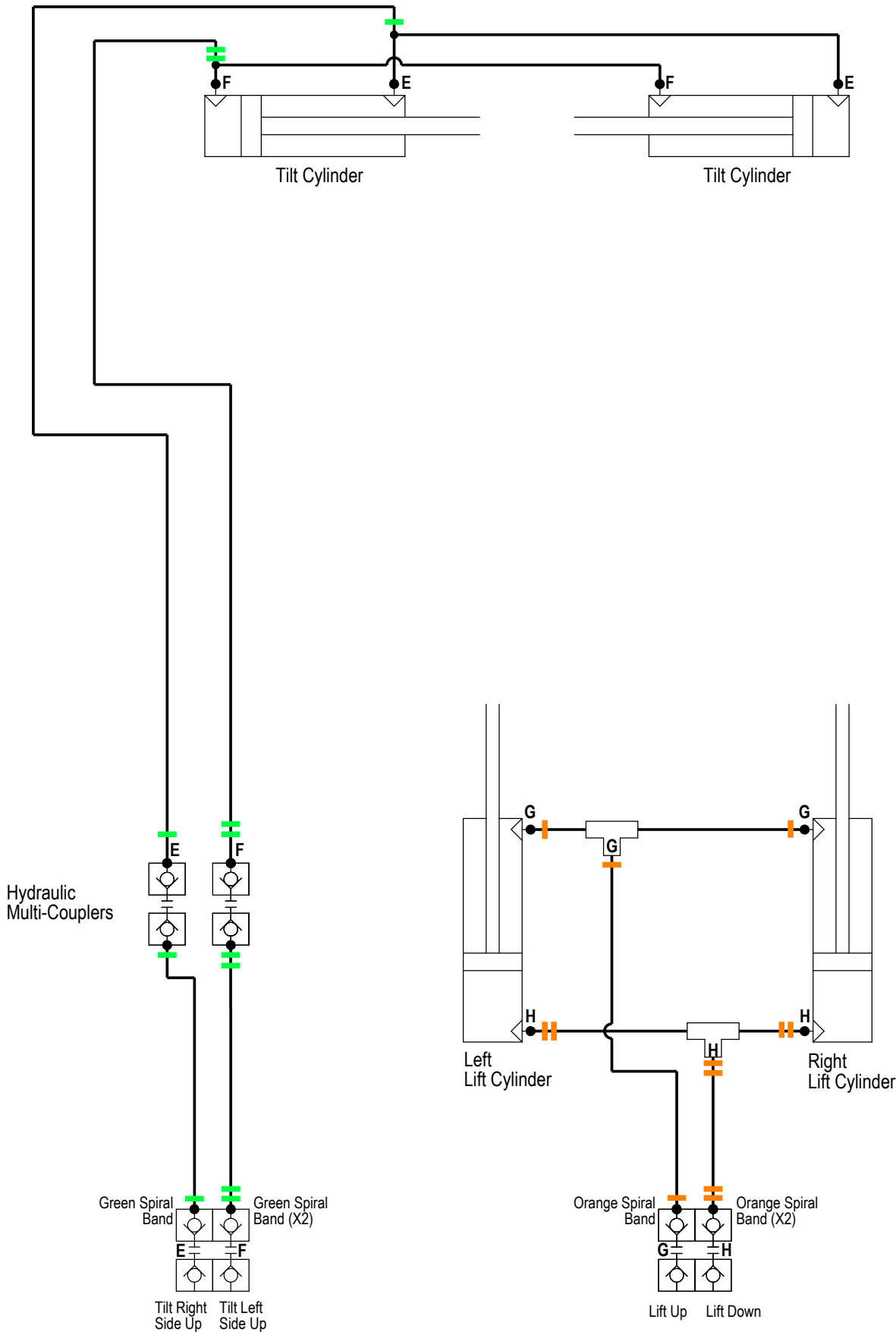

Tractor Service Valve

Improvements

Grouser Products Inc. is continually striving to improve its products. We reserve the right to change prices, specification, or equipment at any time without notice. We also reserve the right to make improvements or changes when it becomes practical and possible to do so without incurring any obligation to make changes or additions to the equipment sold previously.

Warranty

Grouser Products warrants to the original purchaser of each item that the product be free from defects in material and workmanship under normal use and service for a period of **two (2) years for Agriculture Series Blades and one (1) year for Heavy Duty Series from date of original retail delivery.**

The obligation of the consumer under this warranty:

1. To read the operators manual and to operate, lubricate, maintain and store equipment in accordance with the instructions listed in the operators manual.
2. To inspect equipment and if any part needs repair or replacement when continued use would cause damage or wear to other parts or safety.
3. All equipment or parts claimed to be defective in material or workmanship must be made available for inspection at the place of business of a dealer authorized to handle the equipment covered by this warranty, or, upon request by Grouser Products, shipped to the Grouser Products factory in West Fargo, North Dakota.

The obligation of the dealer under this warranty:

1. Complete warranty registration form and submit within 30 days of sale.
2. Contact Grouser Products for authorization prior to performing any warranty repairs or part replacement.
3. Complete warranty request form and submit with photos and supporting documentation.

The obligation of Grouser Products under this warranty:

1. Repair or replace, any equipment or parts, in the judgment of Grouser Products to be defective in material or workmanship.
2. Grouser Products will cover the cost of parts and ground shipping at dealer invoice only.
3. Grouser Products shall have no obligation to bear the cost of labor or transportation in connection with replacement or repair of any such defective parts.

This warranty does not cover:

1. Depreciation or damage caused by normal wear, accident, improper assembly, improper adjustments.
2. Improper maintenance including lack of proper lubrication, or improper use. Including loose bolts, nuts, or fitting due to over tightening or vibration after 20 hours of operation.
3. Repairs or alterations without authorization from a Grouser Products representative.
4. Grouser Products shall have no liability if the equipment has been altered or reworked without the written authorization of Grouser Products.

Grouser Products' parts, which are furnished under this warranty and properly installed, shall be warranted to the same extent as the original parts under this warranty if, and only if, such parts are found to be defective within the original warranty period covering the original equipment.

NO EMPLOYEE OR REPRESENTATIVE OF GROUSER PRODUCTS IS AUTHORIZED TO CHANGE THE WARRANTY IN ANY WAY OR GRANT ANY OTHER WARRANTY.

Contact Us

As always, if you have any questions about your system or other products made by Grouser, feel free to contact us.



755 2nd Ave NW - West Fargo, ND 58078
+1 701-282-7710 | info@grouser.com
www.grouser.com