



770HD NAHT

Owner's Manual

&

Parts Book

For Models:

Case Steiger Quad - 470, 500, 540, 580,
620

Purchase Date
Serial Number
Model Number
Tractor Model
Dealer

Contents

Description	Page
To The Owner & Torque Specifications	2
Maintenance, Safety Precautions	3
Angle / Tilt Function Abbreviation Key & Unpacking Components	3
Undercarriage Installation Instructions	4-5
Assembling Lift Components & Initial System Startup	6
Lift System	7
Hose Routing	8
Page Blank	9
Tractor Side Hydraulic Hose Routing	10-11
NAHT System	12
NAHT Hydraulics	13
Hydraulic Connections	14
Hydraulic Schematic	15
Contact Us, Improvements, & Warranty	16

To The Owner

This manual contains information concerning the operation, adjustment, and maintenance of the 770 blade assembly. You have purchased dependable, long lasting equipment, but only by proper care and operation can you expect to receive the performance and long service built into our products. Please have all operators read this manual carefully and keep the manual available for ready reference. If you have any questions or concerns, contact Grouser Products.

Torque Specifications

All bolts should be tightened to the specifications that are stated. If specifications are not stated, follow torque charts below.

Size	Torque - Dry (ft-lbs)			
	SAE Grade 5		SAE Grade 8	
	UNC	UNF	UNC	UNF
5/16	17	19	24	27
3/8	30	35	45	50
7/16	50	55	70	80
1/2	75	85	110	120
9/16	110	120	150	170
5/8	150	170	210	240
3/4	260	300	380	420
7/8	430	470	600	670
1	640	720	910	1020

Size	Torque - Dry (ft-lbs) Grade 10.9
M18 x 2.50	284
M20 x 2.50	401
M22 x 2.50	547
M24 x 3.00	694

Maintenance

Due to the harsh environment many of our equipment operates in, the following tasks should be performed every 10 hours or less.

- Inspect all equipment before operation for existing or potential damages.
- Lubricate all joints with high quality grease.
- Inspect and tighten all bolts to torque specifications on page 2.
- Check replaceable cutting edge for wear ensuring there is enough material to prevent permanent damage to the blade.
- Make sure all non-rotating pins are secured properly.
- Check hydraulic cylinders and hoses for damage or leaks. For replacement parts, see hydraulic pages for your specific system.
- Check skid shoes for wear and replace if necessary. For adjustment, see page 10.
- Inspect all tilt-ways for aggressive wear. See page 10 for tilt plate adjustment.

Safety Precautions

A careful operator is the best operator. Most accidents can be avoided by observing certain precautions. To help prevent accidents, read and take the following precautions before operating this equipment. In addition to these precautions, please follow all safety and operational instructions of your tractor manufacturer.

The Dozer:

1. The 770 Dozer should be operated only by those who are responsible and instructed to do so.
2. Read the owner's manual carefully before using this equipment. Lack of operating knowledge can lead to accidents.
3. Keep the dozer maintained in reliable and satisfactory condition to ensure your safety.
4. Make sure the area is clear of people before moving any equipment.
5. Do not modify or permit anyone else to modify or alter the equipment and its components without first consulting Grouser Products.

Servicing the Dozer:

1. Read and follow all safety instructions provided by the tractor manufacturer.
2. Always use proper personal safety gear when performing maintenance on equipment.
3. Before servicing, relieve hydraulic pressure, stop engine and fully engage parking brake.
4. Escaping hydraulic fluid under pressure can penetrate skin causing serious injury. If fluid is injected into skin, obtain medical attention immediately.
 - DO NOT use your hand to check for leaks. Use a piece of cardboard or paper to search for leaks.
 - Stop the engine and relieve pressure before connecting or disconnecting lines.
 - Tighten all connections before starting the engine or pressurizing lines.

Storing the Dozer:

1. Thoroughly clean the dozer before storage. Use paint where necessary to prevent rust.
2. Check the dozer for worn or damaged parts. Install new parts as required.
3. Lubricate all pins and joints.

Angle / Tilt Function Abbreviation Key

HAHT	Hydraulic Angle - Hydraulic Tilt	6-Way
HANT	Hydraulic Angle - No Tilt	4-Way
NAHT	No Angle - Hydraulic Tilt	4-Way
NANT	No Angle - No Tilt	2-Way

Unpacking Components

Unstrap and remove the lift frame, hoses, top arms, and any boxes of hardware from the undercarriage. If any components are missing, call Grouser.

Undercarriage Installation Instructions

Caution:

- Always use precaution when working around any equipment.
- Always wear safety glasses.
- Follow tractor manufacturer's safety guidelines when installing this product.

1. Read all instructions prior to installation.
2. Remove existing toolboxes, front weights, and tow cable holder if equipped. Tow cable can be reinstalled later if a bracket is purchased from Grouser Products.
3. If the bulkhead bracket (PN: 18-14370) is not factory installed, attach to the undercarriage with 2 - 1/2" x 1-1/4" bolts (PN: 16-20125) and 1/2" flat washers (PN: 57-20744). See pages 7 and 18-19 for bulkhead fittings, steel lines, and hose locations.
4. If bulkhead covers (PN: 44-14375 & 44-14376) are not factory installed, verify that all hydraulics are installed correctly and then attach the covers to the U/C with 6 - 1/2" x 1-1/4" bolts (PN: 16-20125) and 1/2" flat washers (PN: 57-20744).
NOTE: If rear 1" bolts are installed on the undercarriage, back out so the undercarriage will fit on the rear plate on the tractor frame.
5. Drill out holes in the tractor frame that line up with the front holes on the undercarriage to 1".
6. Position the undercarriage (U/C) under tractor and center on the frame of the tractor.
7. Lift the rear of the U/C up and set the top plates of the U/C on the cross member. Push the U/C back until the vertical push plates are firmly against the cross member. Lift the U/C to within 3/4" of touching the tractor frame.
8. Insert 8 - 1" x 3-1/2" bolts (PN: 16-20564) with a 1" hardened flat washer (PN: 57-20759) on each bolt through the front holes of the tractor frame that line up with the front vertical holes of the U/C.
9. After all bolts are through the tractor frame and U/C, attach with a 1" heavy washer (PN: 57-3682) and a 1" nut (PN: 70-20599). Verify that the rear of the U/C is firmly against the cross member.
10. At the rear of the undercarriage and pivot area of the tractor, hook the rear hose routing bracket to the tractor frame and bolt to the rear of the undercarriage with 1" x 3" bolts (PN: 16-20562), 1" hardened flat washers (PN: 57-20759) and 1" nuts (PN: 70-20599). The nut will fit between the plates on the brackets. See attached diagram for clarification.
11. Center the bracket on the undercarriage and tractor as close as you can. Torque the 1" bolts to 600 ft-lbs. There can be a gap between the bracket and the undercarriage.
12. Tighten the rear vertical bolts up tight against the bottom of the tractor frame. Torque the rear vertical 1" bolts to 500-600 ft-lbs.
13. Torque front 1" vertical bolts to 903 ft-lbs..
14. Attach the upper support arms (PN: 11-17740-R,L) to the U/C with 2 - 1" x 3-1/2" bolts (PN: 16-20564), 4 - 1" heavy duty flat washer (PN: 57-20819), and 2 - 1" nuts (PN: 70-20599) on each side of the U/C.
15. Attach the upper support arms to the tractor with a 1-1/4" x 3-1/2" bolt (PN: 16-20896) and a 1-1/4" flat washer (PN: 57-11671) on each side.
16. Remove the 2 - 24mm bolts and spacers from front axle on the left and right side of the tractor. Discard the spacers.
17. Attach the quad yoke brackets (PN: 18-14550-R,L) to each side of the U/C with 6 - 1" x 2" bolts (PN: 16-20558) and a 1" x .375" thick washer (PN: 57-3682) on each bolt.
18. Dip the previously removed 24mm bolts in W30 oil and install the yoke brackets with the 24mm bolt and a heavy flat washer (PN: 57-20819) on each bolt.
19. Once all bolts have been installed, torque the 1-1/4" bolts to 1,105 ft-lbs., the 1" bolts to 903 ft-lbs, and the 24mm bolts to 555 ft-lbs.
20. Bolt the side bolt cover (PN: 44-15575) to both sides of the undercarriage with 1/2" x 1-1/4" bolts (PN: 16-20125) and a 1/2" flat washer (PN: 57-20744) on each bolt.
21. Attach the bottom covers (PN: 44-14382-R,L) to the undercarriage with 1/2" x 1-1/4" bolts (PN: 16-20125) and 1/2" flat washers (PN: 57-20744).
22. After first 8 hours of use, re-torque all bolts. Check all fasteners regularly to ensure proper operation of equipment.

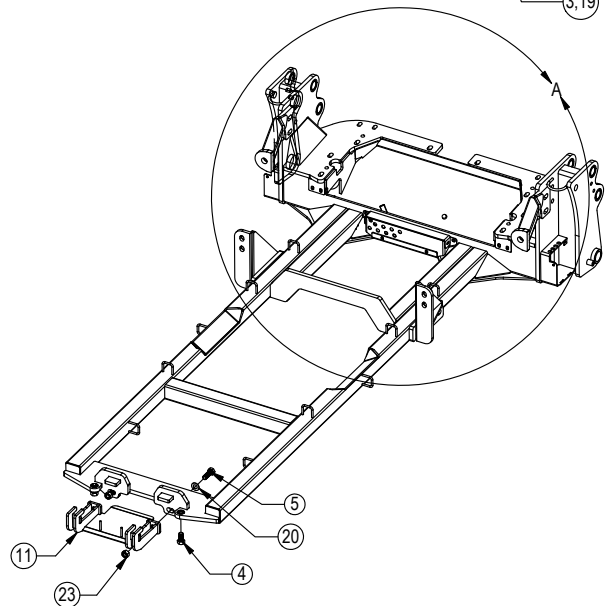
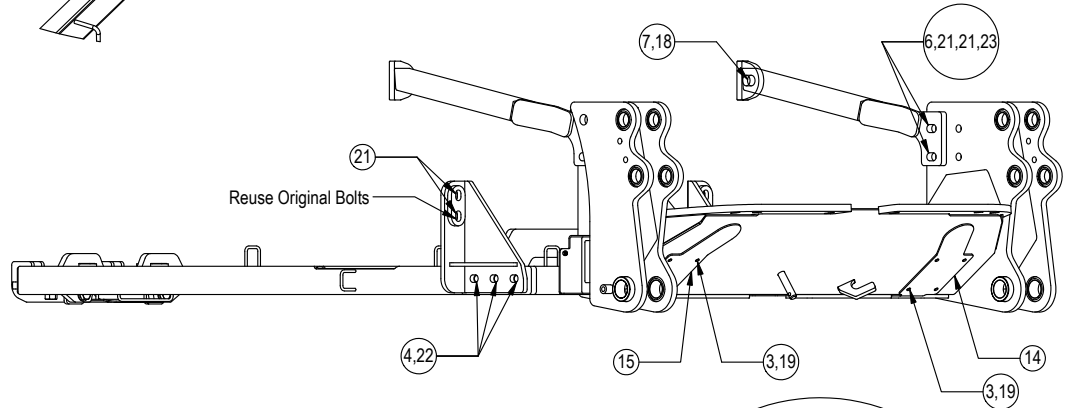
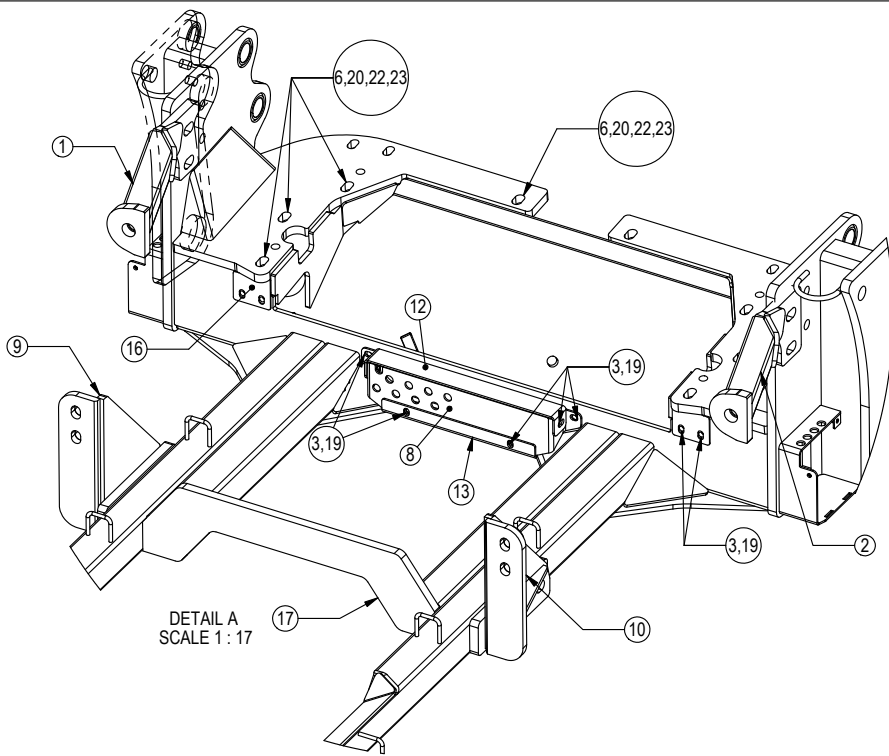

* Parts Not Shown

Item No.	Qty.	Part No.	Description
1	1	11-17740-L	Upper Undercarriage Support Arm Left - Quad Tier 4B
2	1	11-17740-R	Upper Undercarriage Support Arm Right - Quad Tier 4B
3	20	16-20125	1/2" x 1-1/4" Hex Bolt Gr 5 NC
4	8	16-20558	1" x 2" Hex Bolt Gr 8 NC
5	2	16-20562	1" x 3" Hex Bolt Gr 8 NC
6	12	16-20564	1" x 3-1/2" Hex Bolt Gr 8 NC
7	2	16-20896	1-1/4" x 3-1/2" Hex Bolt Gr 5 NC Zinc
8	1	18-14370	Bracket, Bulkhead - AG Wide Frame
9	1	18-14550-L	Steiger Quad Yoke Bracket - Left
10	1	18-14550-R	Steiger Quad Yoke Bracket - Right
11	1	18-17280	Hose Routing Bracket
12	1	44-14375	Plate, Top Bulkhead Cover - AG Wide Frame
13	1	44-14376	Plate, Bottom Bulkhead Cover - AG Wide Frame
14	1	44-14382-L	Plate, Bottom Cover Left - AG Wide Frame
15	1	44-14382-R	Plate, Bottom Cover Right - AG Wide Frame
16	2	44-15575	Plate, 770 Undercarriage Side Bolt Cover
17	1	54-19297	770HD Steiger / T9 Large Frame Quad and Wheeled UC
18	2	57-11671	1-1/4" Flat Washer
19	20	57-20744	1/2" Flat Washer
20	10	57-20759	1" SAE Hardened Flat Washer - 2" OD
21	12	57-20819	1" Flat Washer Heavy Duty Gr 8 (USS)
22	14	57-3682	2.50 OD X 1.00" ID x .375" Washer CZ Plated
23	14	70-20599	1" Hex Nut Gr 8 NC

TITLE:
770 Steiger Quad UC Assy.

Assembling Lift Components

Now that the undercarriage is installed, some assembly of components is necessary. Follow the steps listed below. Refer to Page 7 for the correct hardware and orientation of parts.

1. Remove all pins on each side of the undercarriage.
2. Position the lift frame between the two plates on both sides of the undercarriage.
3. Align the lift frame to the bottom holes of the undercarriage and attach with the proper pins and hardware.
4. Attach the cylinders and top arms to the undercarriage with the proper pins and hardware.
5. Remove the male quick attaches that are in the female quicks on the blade, angle frame, or tilt frame.
6. Attach the male quick attaches to the lift frame and top arms with the proper pins and hardware.
7. If the quick couplers and coupler mount are not already attached to the left top arm, attach the coupler mount to the left top arm with 4 - 3/8" flange nuts. See Page #18 for proper orientation.
8. Take the lift hoses that are already attached to the furthest forward fittings on the left and right side of the undercarriage and attach them to the lift cylinders.
Note: For Step #9-15, refer to Page #18-20 for further information on hose routing and hose positions. The amount and location of the female couplers is determined by functions the blade is set up for.
9. Run the remaining hoses thru the hose loop on the top arm and attach a 90° fitting to all the hoses.
10. Install a female quick coupler onto each 90° fitting from the previous step.
11. Install each coupler into the designated hole on the coupler mount and hold them in place with the coupler retainer plate, 3/8" x 3/4" bolts and 3/8" flange nuts.
12. Take the long hoses and attach each one to their designated fitting at the center of the undercarriage.
13. Mark each hose clearly so that once the hoses are routed to the back of the tractor, it's easy to determine what cylinder base or rod end they are connected to.
14. Route the hoses thru the hose loops on the undercarriage.
15. Continue to route the hoses thru the tractor. Keep away from all moving parts. Refer to Page 8 for hose routing.
16. If applicable, attach the wire harness to the coupler mount on the top arm with 1/4" bolts and 1/4" nuts. Run the other end of the wire harness up into the cab of the tractor.
17. Locate the keyed power source. Connect the red wire to positive and the black to ground. If you have the electric angle system, install provided switch (PN: 69-14679) into an open switch hole in the right overhead console or another convenient place in the tractor. Connect the wire harness to the switch. If you have the 2 lever angle system, attach the 2-lever plug (PN: 69-14683) to the wire harness.
18. Get the blade ready to hook up by removing the 3/4" pin (#19 on Page 11) so that the skid shoes can move freely. The blade will lean back further for easier connection onto the male quick attaches. Store the pin in the empty hole right behind the hole you just took the pin out of.
19. Pull the pin puller handle on the left side of the quick attach system towards the outside of the blade to open the quick attach system. Refer to Page #12-13 for further clarification on the quick attach system.
20. Drive the tractor forward slowly until the top edge of the male quick attach is under the top lip of the female quick attach already on the blade assembly.
21. Lift the male quick attaches up till the blade is off the ground and the female quick attaches are against the front of the male quick attaches.
22. Shut off machine and set the parking brake.
23. Move the pin puller handle on the left side of the blade assembly towards the center of the blade to lock the blade in place and use the latch to lock the handle in place. If applicable, turn up the blade stands on the blade.
24. Plug the male couplers into the female couplers on the top arm. Refer to Page #20 for proper coupler locations for all functions. If applicable, plug the male blade break away end of the wire harness into the female blade break away end of the wire harness on the top arm.
25. Lock the Mushroom Skid Shoe Link back in place with the 3/4" pin you moved in Step #18 above.
26. To disconnect the blade, see Page 10.
27. Refer to Page 21 for clarification on the wire harness ends.

Initial System Startup

Start the tractor and run the blade thru all the functions. If any function does not work properly, bleeding of the system may be required. If problem still persists, call Grouser Products.

Hoses Not Drawn To Scale

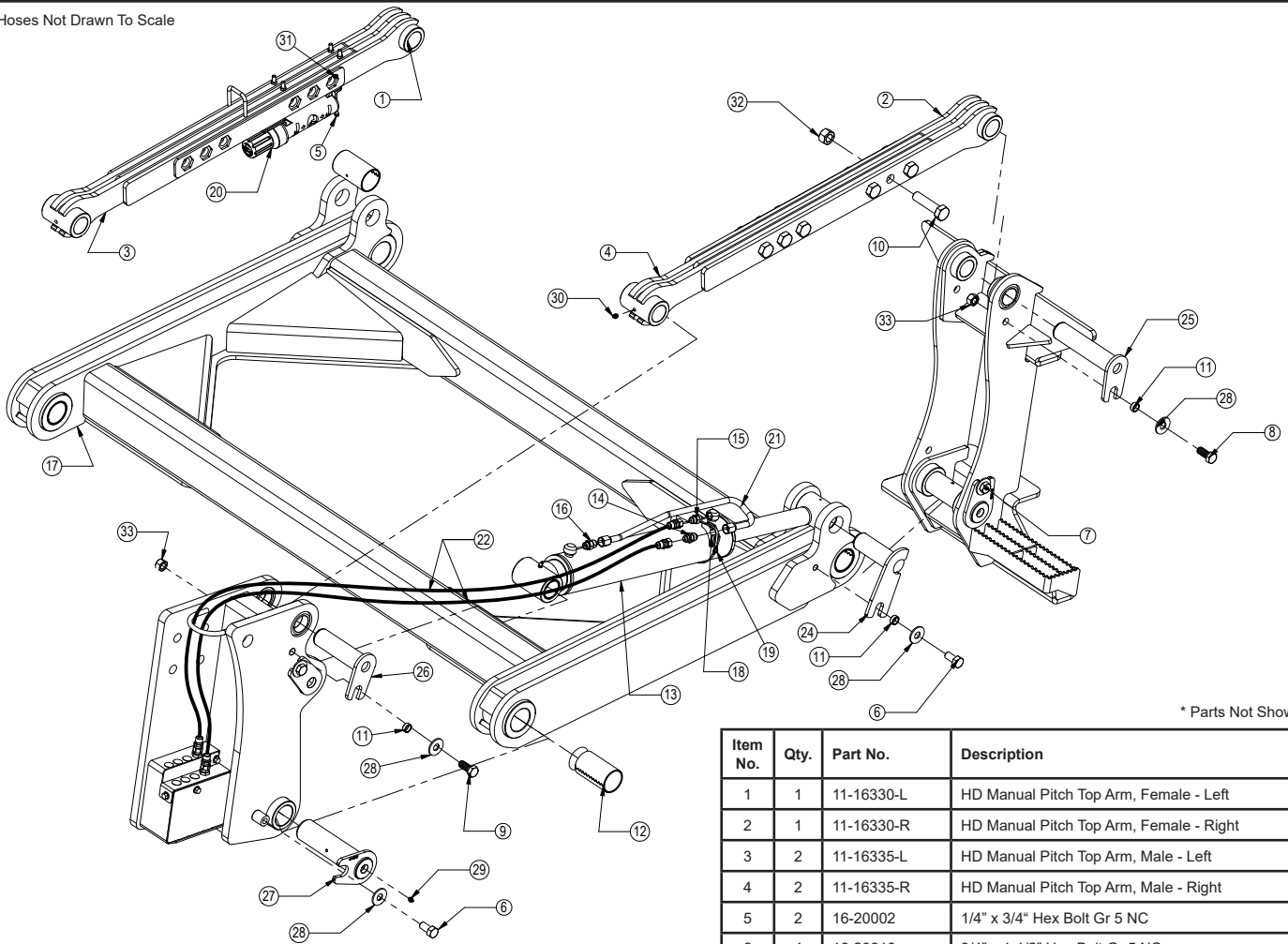

* Parts Not Shown

Item No.	Qty.	Part No.	Description
1	1	11-16330-L	HD Manual Pitch Top Arm, Female - Left
2	1	11-16330-R	HD Manual Pitch Top Arm, Female - Right
3	2	11-16335-L	HD Manual Pitch Top Arm, Male - Left
4	2	11-16335-R	HD Manual Pitch Top Arm, Male - Right
5	2	16-20002	1/4" x 3/4" Hex Bolt Gr 5 NC
6	4	16-20216	3/4" x 1-1/2" Hex Bolt Gr 5 NC
7	2	16-20217	3/4" x 1-3/4" Hex Bolt Gr 5 NC
8	2	16-20219	3/4" x 2-1/4" Hex Bolt Gr 5 NC
9	4	16-20220	3/4" x 2-1/2" Hex Bolt Gr 5 NC
10	12	16-20566	1" x 4" Hex Bolt Gr 8 NC
11	10	19-13515	3/4" ID - Non Rotating Pin Spacer Bushing
12	4	19-13525	2.75 x 2.50 x 4.75 Spring Bushing
13	2	26-5200	5x20 Cylinder - Tube Ends (C50-115A)
14	2	31-11699-10-10	JIC Union (2403-10-10)
15	2	31-34042	Straight JIC x O-Ring (6400-10-10)
16	2	31-34203	Straight Long JIC x O-Ring (6400L-10-10)
17	1	32-17000	770HD Lift Frame
18	2	34-12932	Cylinder Saddle (ZR518)
19	2	34-12933	Hose Clamp
20	1	34-14961	Manual Canister
21	2	35-12931	Formed Steel Line (Lift Cylinder)
22	4	35-12632-0630	63" x 5/8" -10JIC/-10JIC Abrasion Resistant Hose
23*	1	43-12929-L	Pin Weld - Long Ear (Lift Cyl. / Lift Frame) - Left
24	1	43-12929-R	Pin Weld - Long Ear (Lift Cyl. / Lift Frame) - Right
25	2	43-13478	Pin Weld (Top Arm / QA)
26	4	43-13482	Pin Weld (Top Arm / UC & Lift Cyl. / UC)
27	4	43-14725	Pin Weld (Lift Frame / UC)
28	12	57-20747	3/4" Flat Washer
29	4	58-9369	Grease Zerk 1/8" NPT Straight
30	4	58-9372	Grease Zerk 1/8" NPT 90°
31	2	70-20610	1/4" Nyloc Hex Nut Gr 5 NC
32	12	70-20599	1" Hex Nut Gr 8 NC
33	8	70-20607	3/4" Hex Center Lock Nut Gr 2 NC

NOTE: When ordering cylinder seal kits, the part number on the cylinder is needed. The number is stamped on the base end of the cylinder opposite of the hydraulic ports.

No. On Cylinder	Part No.	Description
26-5200	49-11640	Seal Kit 5 x 20 (SKC50-115A) Nitrided Rod

Item No.	Qty.	Part No.	Description
1	4	16-20139	1/2" x 5-1/2" Hex Bolt Gr 5 NC
2	1	44-17208	770 CNH Rear UC Hose Routing Plate
3	4	44-17245	770 CNH Hose Holding Plate
4	4	53-15528	Round Tube, Hose Routing Spacer - 3/4"
5	4	54-20744	1/2" Flat Washer
6	4	70-20604	1/2" Hex Center Lock Nut Gr 2 NC
7	2	70-20872-10	20mm Hex Nut 2.5 Pitch Class 10 Zinc

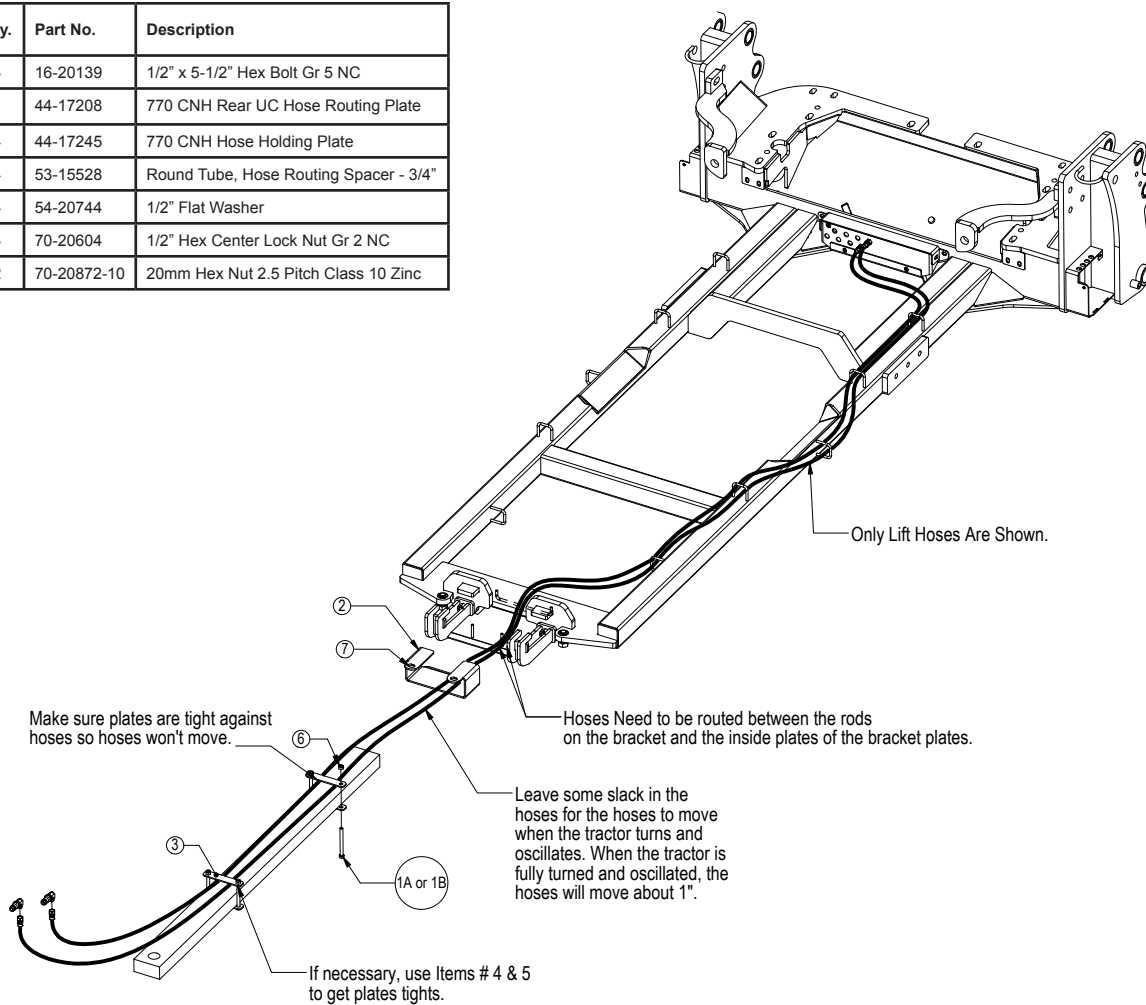

1. Attach the rear hose routing plate (PN: 44-17208) to the tractor frame behind the pivot point and before the drawbar. There will be 2 bolts sticking down. Attach with a 20mm nut (PN: 70-20872-10) on each side. Make sure the lip of the plate is facing towards the front of the tractor. See picture below for clarification.
 2. Check all fasteners regularly to ensure proper operation of equipment.
- For the following steps, refer to the hose routing diagram for further clarification.**
3. Attach the 293" hoses to the front of the undercarriage where all the steel lines come to the center of the undercarriage.
 4. Route all the hoses from the front of the undercarriage, thru the hose loops on the undercarriage and thru the large loop at the rear of the undercarriage. Send hoses thru the bracket at the pivot point but stay on the outside of the rods that are by the center large nut on the tractor. The hoses should be between the rods on the bracket and the inside plates of the bracket.
 5. Route the hoses thru the hose routing plate that was installed in Step #1.
 6. Use Zip Ties to group some hoses on the left and right side of the hose routing plate. Strap the zip Ties over the top part of the routing plate that is bolted to the tractor frame to keep the hoses towards the outside of each side of the routing plate.
 7. Continue to route the hoses down the top of the drawbar to the back of the tractor where you can plug them into the tractor SCV Ports.
 8. Strap the hoses to the drawbar with a set of hose holding plates (PN: 44-17245) in 2 locations. Place 1 set as close to the front of drawbar as possible and the other behind the axle before the hoses would be routed upwards to be plugged in.
 9. Make sure to keep some slack in the hose between the pivot point of the tractor and the first set of hose holding plates. The hoses will move when the tractor moves and oscillates.
 10. For each set of plates, use 2 - 1/2" x 5-1/2" bolts (PN: 16-20139) and 2 - 1/2" nuts (PN: 70-20604). Put the bolts in from the bottom with the nuts on the top.
 11. Tighten the 1/2" nuts so the hoses are tight and don't move. If you have the nuts as far as they go and you can't get the plates tight against the hoses, use the provided 3/4" spacers (PN:34-15528) and a 1/2" washer (PN: 57-20744) between the plates and the nuts to get everything tight against the top of the drawbar.
 12. Make sure you still have some slack in the hoses by the pivot area so the hoses don't get pulled too tight when the tractor moves but don't make them too loose that they will get caught on any debris. Turn the tractor and oscillate the tractor to verify there is enough slack.
 13. After first 8 hours of use, re-torque all bolts.
 14. Check all fasteners regularly to ensure proper operation of equipment.

PAGE LEFT BLANK INTENTIONALLY

Hoses Not Drawn To Scale

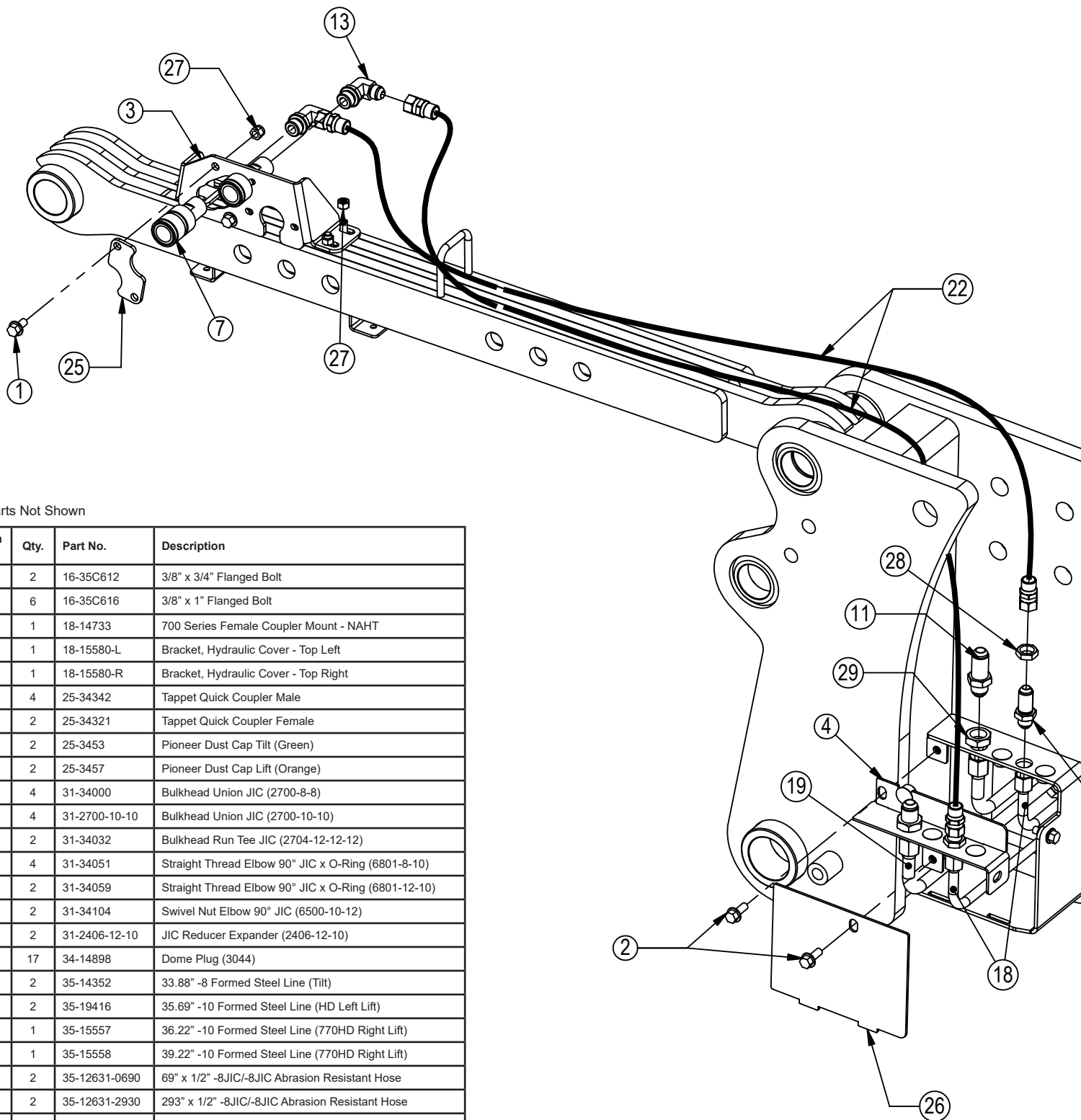

* Parts Not Shown

Item No.	Qty.	Part No.	Description
1	2	16-35C612	3/8" x 3/4" Flanged Bolt
2	6	16-35C616	3/8" x 1" Flanged Bolt
3	1	18-14733	700 Series Female Coupler Mount - NAHT
4	1	18-15580-L	Bracket, Hydraulic Cover - Top Left
5	1	18-15580-R	Bracket, Hydraulic Cover - Top Right
6	4	25-34342	Tappet Quick Coupler Male
7	2	25-34321	Tappet Quick Coupler Female
8*	2	25-3453	Pioneer Dust Cap Tilt (Green)
9*	2	25-3457	Pioneer Dust Cap Lift (Orange)
10	4	31-34000	Bulkhead Union JIC (2700-8-8)
11	4	31-2700-10-10	Bulkhead Union JIC (2700-10-10)
12	2	31-34032	Bulkhead Run Tee JIC (2704-12-12-12)
13	4	31-34051	Straight Thread Elbow 90° JIC x O-Ring (6801-8-10)
14	2	31-34059	Straight Thread Elbow 90° JIC x O-Ring (6801-12-10)
15	2	31-34104	Swivel Nut Elbow 90° JIC (6500-10-12)
16	2	31-2406-12-10	JIC Reducer Expander (2406-12-10)
17	17	34-14898	Dome Plug (3044)
18	2	35-14352	33.88" -8 Formed Steel Line (Tilt)
19	2	35-19416	35.69" -10 Formed Steel Line (HD Left Lift)
20	1	35-15557	36.22" -10 Formed Steel Line (770HD Right Lift)
21	1	35-15558	39.22" -10 Formed Steel Line (770HD Right Lift)
22	2	35-12631-0690	69" x 1/2" -8JIC/-8JIC Abrasion Resistant Hose
23	2	35-12631-2930	293" x 1/2" -8JIC/-8JIC Abrasion Resistant Hose
24	2	35-12637-2930	293" x 3/4" -12JIC/-12JIC Abrasion Resistant Hose
25	1	44-14734	700 Series Female Coupler Retainer - NAHT
26	2	44-15120	700 Series Side Cover Plate - Left
27	6	70-20622	3/8" Flange Hex Nut NC
28	4	70-20807	3/4" Hex Jam Nut
29	4	70-20808	7/8" Hex Jam Nut
30	2	70-20809	1-1/16" Hex Jam Nut

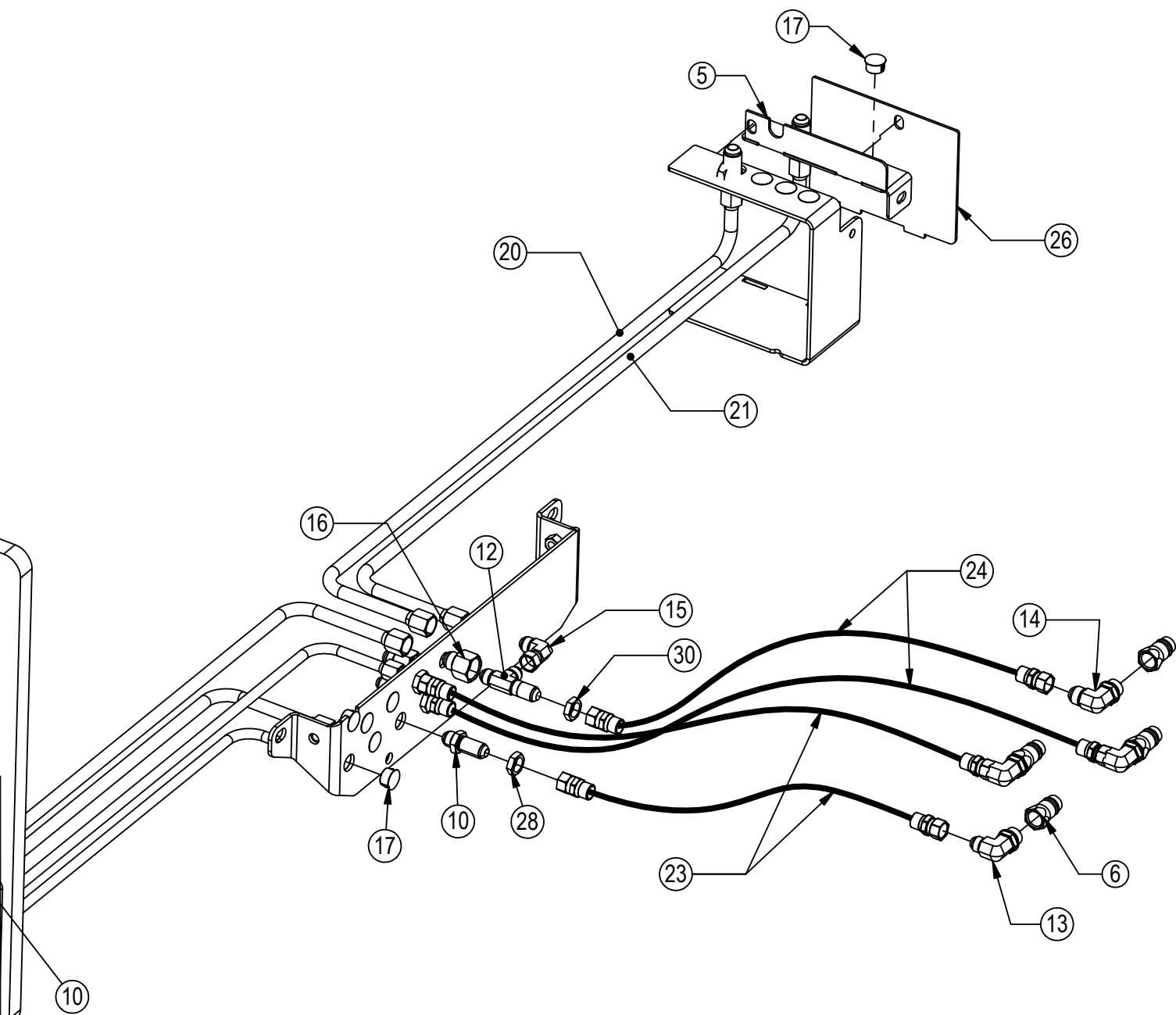

ITEM NO.	PART NO.	QTY.	DESCRIPTION
1	32-19515	1	Tilt Frame Weld
2	43-13620	2	Pin, QA Locking
3	27-2409	1	Pinch Area, Hand
4	27-9503	1	Pinch Point, Foot
5	19-7774	2	1" x 1" Spring Bushing

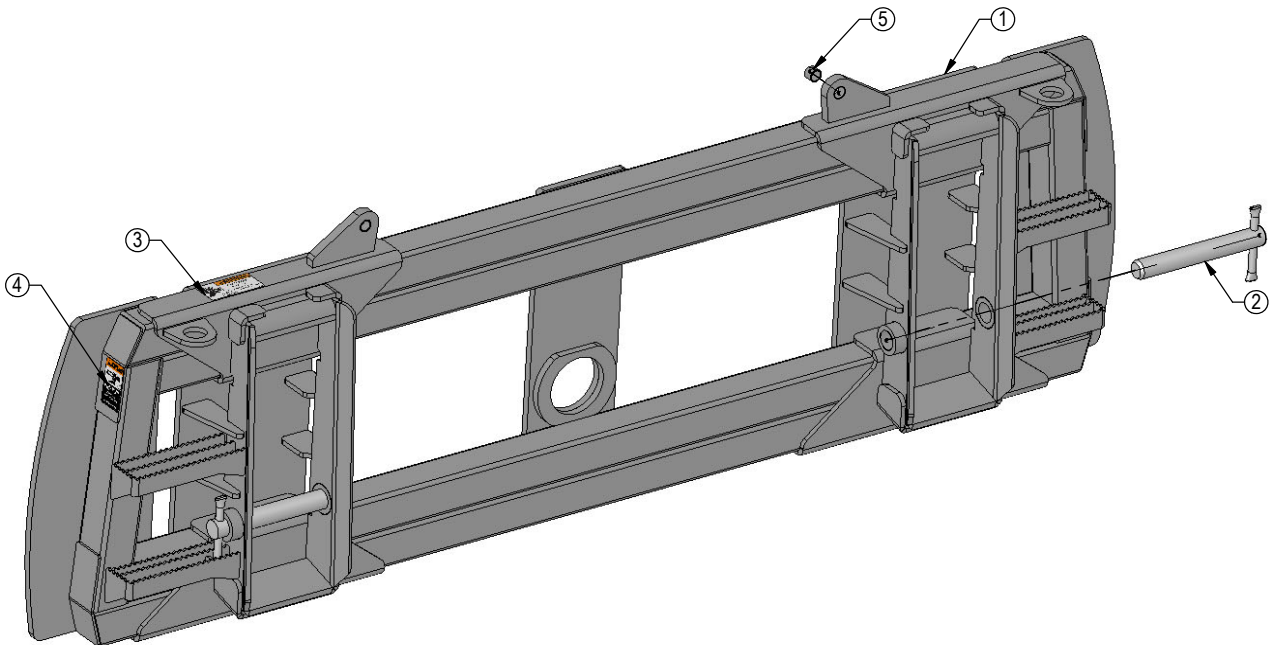

ITEM NO.	PART NO.	QTY.	DESCRIPTION
1	16-35C612	2	3/8" x 3/4" Flange Bolt
2	18-14733R1	1	Mount, Coupler
3	25-34332	4	Tappet Quick Coupler Male
4	26-34810	2	5x8 Cylinder w/ Clevis Ends
5	31-34040	2	Straight JIC x O-Ring
6	31-34050	1	Straight Thread Elbow 90° JIC x O-Ring
7	31-34051	2	Straight Thread Elbow 90° JIC x O-Ring
8	31-34060	1	Branch Tee JIC x O-Ring
9	31-34080	1	Swivel Nut Branch Tee JIC
10	31-34100	1	Swivel Nut Elbow 90° JIC
11	35-12631-0370	1	37" x 1/2" -8JIC/-8JIC Abrasion Resistant Hose
12	35-12631-0390	2	39" x 1/2" -8JIC/-8JIC Abrasion Resistant Hose
13	35-12631-0470	1	47" x 1/2" -8JIC/-8JIC Abrasion Resistant Hose
14	43-7767	4	Cylinder Pin Clip
15	43-7994R3	2	Pin
16	43-7995R4	2	Pin
17	44-14734	1	Plate, Retainer
18	70-20582	6	3/8" Hex Nut Gr 5 NC CZ

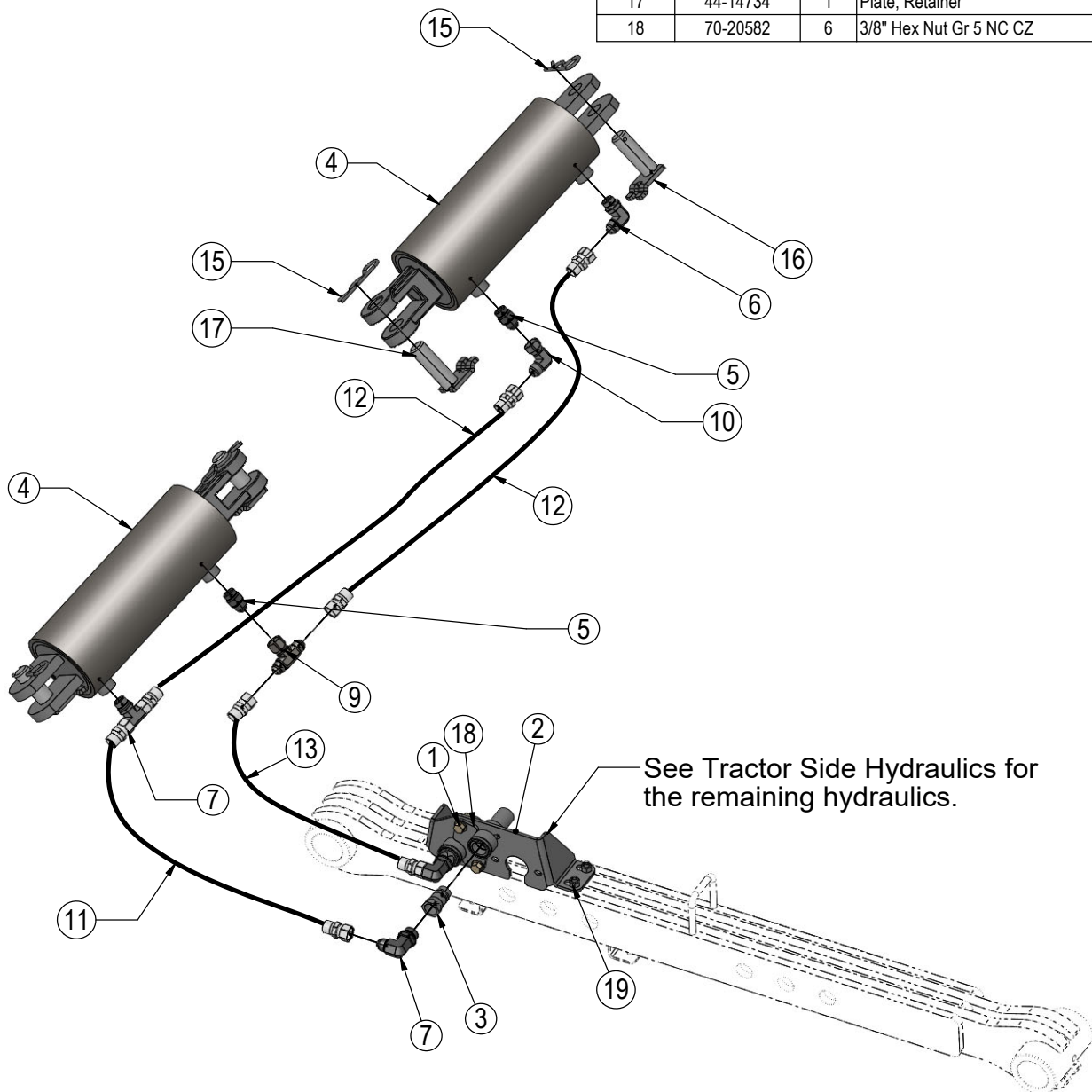

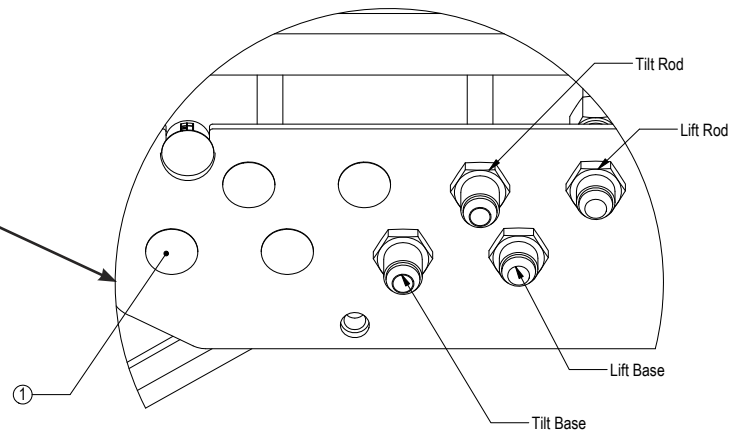
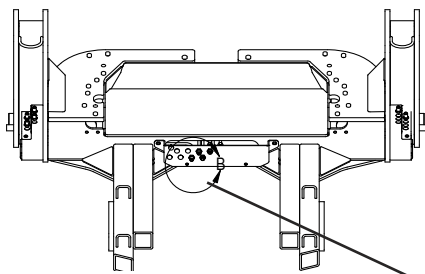
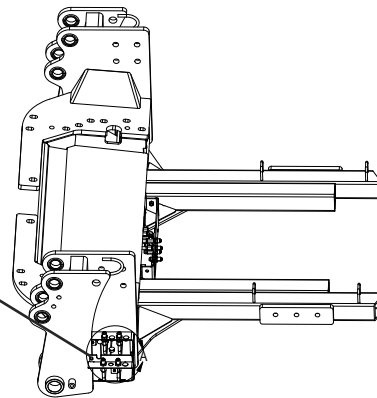
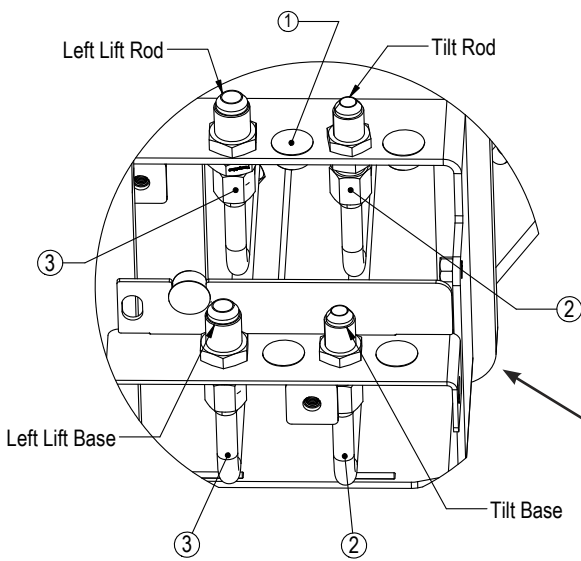
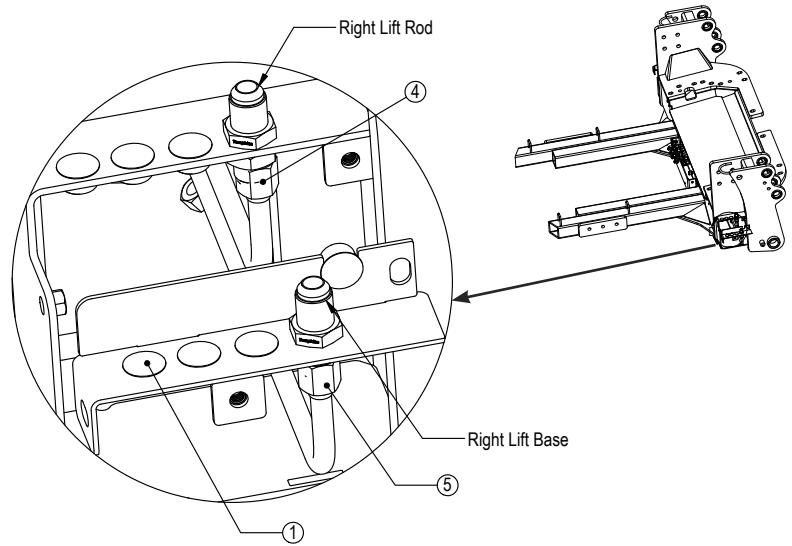
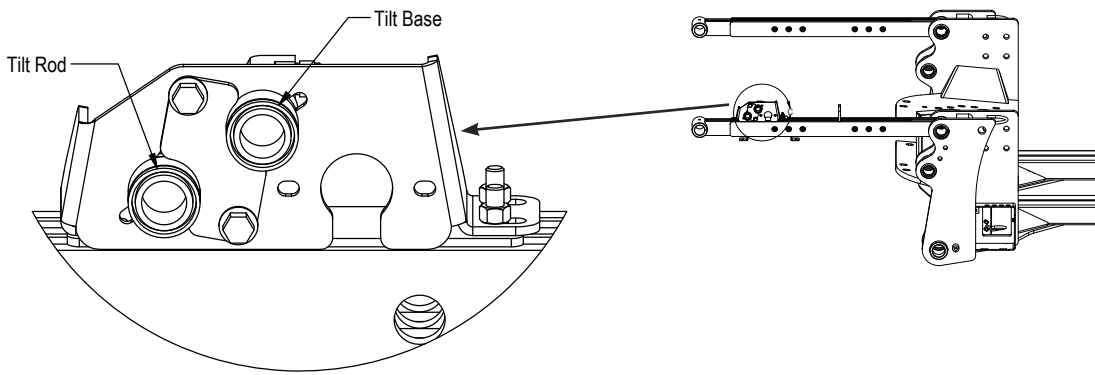

Item	Qty.	Part No.	Description
1	17	34-14898	Dome Plug (3044)
2	2	35-14352	33.88" -8 Formed Steel Line (Tilt)
3	2	35-19416	35.69" -10 Formed Steel Line (HD Left Lift)
4	1	35-15557	36.22" -10 Formed Steel Line (770HD Right Lift)
5	1	35-15558	39.22" -10 Formed Steel Line (770HD Right Lift)

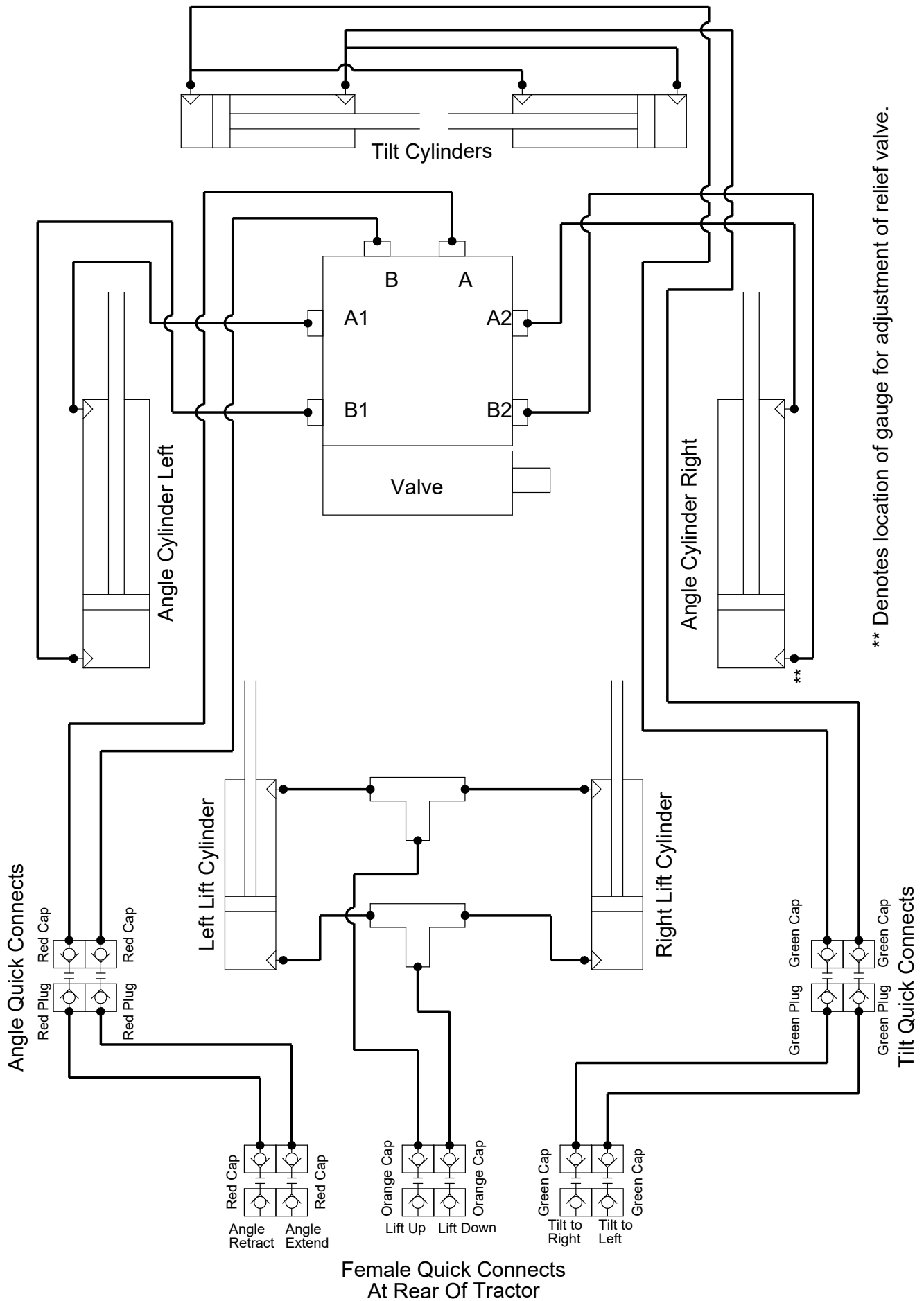

** Denotes location of gauge for adjustment of relief valve.

Improvements

Grouser Products Inc. is continually striving to improve its products. We reserve the right to change prices, specification, or equipment at any time without notice. We also reserve the right to make improvements or changes when it becomes practical and possible to do so without incurring any obligation to make changes or additions to the equipment sold previously.

Warranty

Grouser Products warrants to the original purchaser of each item that the product be free from defects in material and workmanship under normal use and service for a period of **two (2) years for Agriculture Series Blades and one (1) year for Heavy Duty Series from date of original retail delivery.**

The obligation of the consumer under this warranty:

1. To read the operators manual and to operate, lubricate, maintain and store equipment in accordance with the instructions listed in the operators manual.
2. To inspect equipment and if any part needs repair or replacement when continued use would cause damage or wear to other parts or safety.
3. All equipment or parts claimed to be defective in material or workmanship must be made available for inspection at the place of business of a dealer authorized to handle the equipment covered by this warranty, or, upon request by Grouser Products, shipped to the Grouser Products factory in West Fargo, North Dakota.

The obligation of the dealer under this warranty:

1. Complete warranty registration form and submit within 30 days of sale.
2. Contact Grouser Products for authorization prior to performing any warranty repairs or part replacement.
3. Complete warranty request form and submit with photos and supporting documentation.

The obligation of Grouser Products under this warranty:

1. Repair or replace, any equipment or parts, in the judgment of Grouser Products to be defective in material or workmanship.
2. Grouser Products will cover the cost of parts and ground shipping at dealer invoice only.
3. Grouser Products shall have no obligation to bear the cost of labor or transportation in connection with replacement or repair of any such defective parts.

This warranty does not cover:

1. Depreciation or damage caused by normal wear, accident, improper assembly, improper adjustments.
2. Improper maintenance including lack of proper lubrication, or improper use. Including loose bolts, nuts, or fitting due to over tightening or vibration after 20 hours of operation.
3. Repairs or alterations without authorization from a Grouser Products representative.
4. Grouser Products shall have no liability if the equipment has been altered or reworked without the written authorization of Grouser Products.

Grouser Products' parts, which are furnished under this warranty and properly installed, shall be warranted to the same extent as the original parts under this warranty if, and only if, such parts are found to be defective within the original warranty period covering the original equipment.

NO EMPLOYEE OR REPRESENTATIVE OF GROUSER PRODUCTS IS AUTHORIZED TO CHANGE THE WARRANTY IN ANY WAY OR GRANT ANY OTHER WARRANTY.

Contact Us

As always, if you have any questions about your system or other products made by Grouser, feel free to contact us.



755 2nd Ave NW - West Fargo, ND 58078
+1 701-282-7710 | info@grouser.com
www.grouser.com