

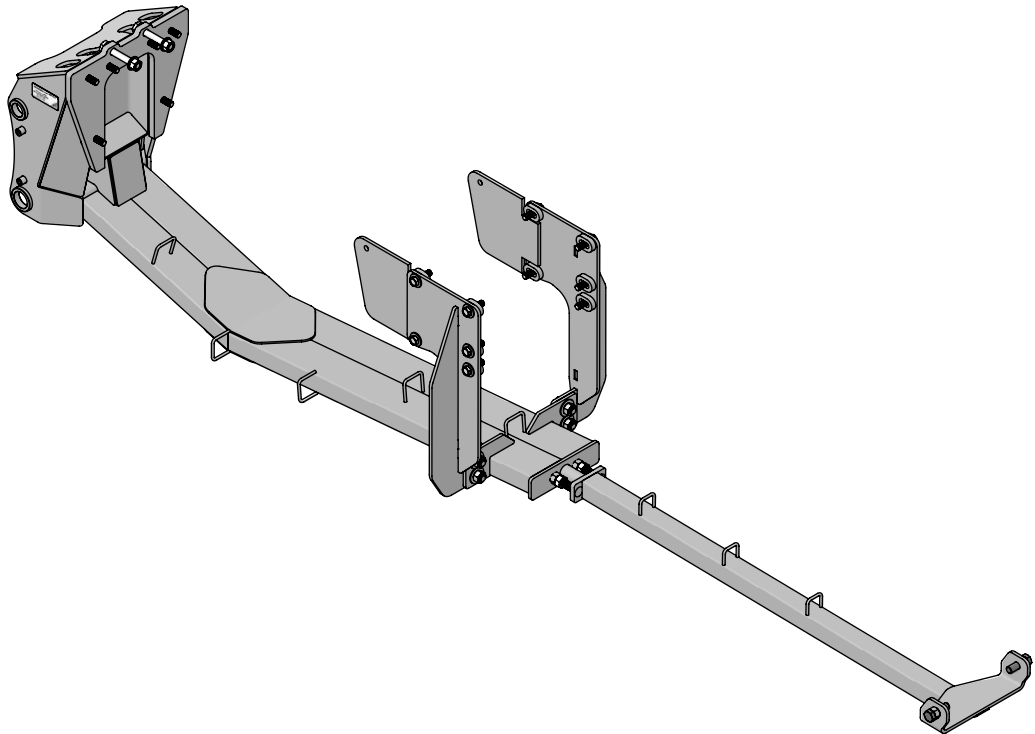

New Holland T8 - Tier 4A & 4B Undercarriage Installation Instructions



For Models:

New Holland TerraGlide Front Axle (HD PST & CVT):

(T4A) T8.420

(T4B) - T8.435

Model Year 2013-Current

Purchase Date
Serial Number
Model Number
Tractor Model
Dealer

To The Owner

This manual contains information concerning the installation of the undercarriage. You have purchased dependable, long lasting equipment, but only by proper care and operation can you expect to receive the performance and long service built into our products. Please have all operators read this manual carefully and keep the manual available for ready reference. If you have any questions or concerns, contact Grouser Products.

Caution:

- Always use caution when working around any equipment.
- Always wear safety glasses.
- Follow tractor manufacturer's safety guidelines when installing this product.
- Use paint where necessary to prevent rust.
- Do not modify or permit anyone else to modify or alter the equipment and its components without first consulting Grouser Products.

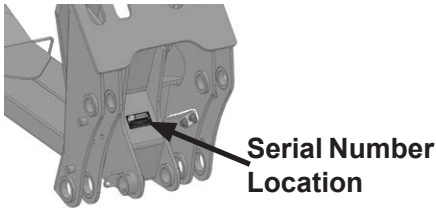

Note:

- When installing hardware, only finger tighten until all hardware is in place.
- A full diagram of the assembly with the full list of parts is on pages 4-5.
- Unstrap and remove any components that are attached for shipping.
- Read all instructions prior to performing installation.



To ensure the safety of those working under and around the machine, apply parking brake, remove key from ignition, and block tires before working on the machine.

Installation

1. Remove front 3-point or weights and weight bracket from front of tractor if necessary.

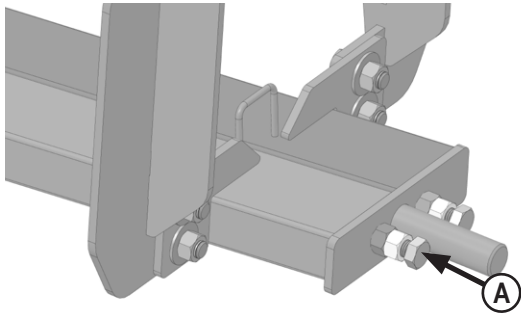

2. Install 2 - 1" x 6" bolts and 2 - 1" nuts at rear of undercarriage (A). Turn 1" bolts in for installation. The bolts will be adjusted after push pole is installed in a later step.

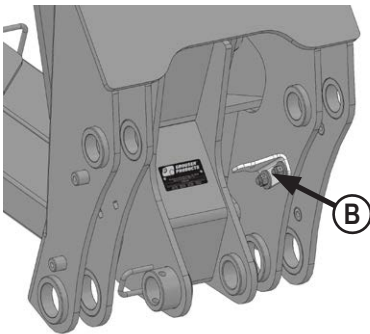

3. Remove hose clamp bracket (B) from front of undercarriage mount to gain access to front bolts if necessary.
4. Position the undercarriage under tractor and center on the frame of the tractor.

NOTE: When lifting the undercarriage, watch for any potential pinching of hoses or any other components to prevent damage.

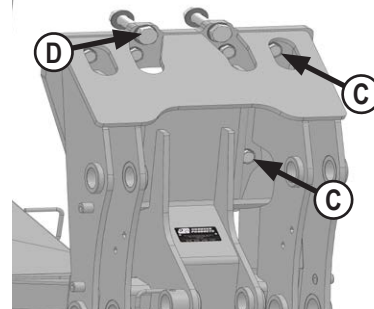

5. Lift undercarriage and attach front of undercarriage to tractor with 6 - 20mm x 70mm bolts and 6 - 3/4" hardened washers in bottom holes (C).
6. For top 2 holes, use 2 - 24mm x 150mm bolts, and 4 - 1" hardened washers, and 2 - 24mm nuts (D).

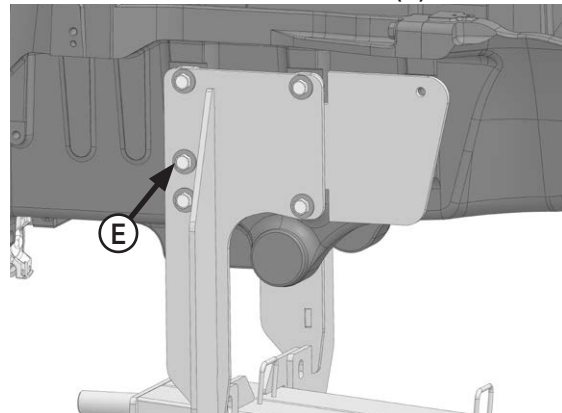

NOTE: See diagram on page 4-5 for information on how to modify side pads.

7. Attach side brackets to tractor with 10 - 20mm x 70 mm bolts and 10 - 3/4" flat washers (E).
8. If a ground boss is on tractor frame, reattach along with side bracket and use a 20mm x 120mm bolt and 3/4" washer.

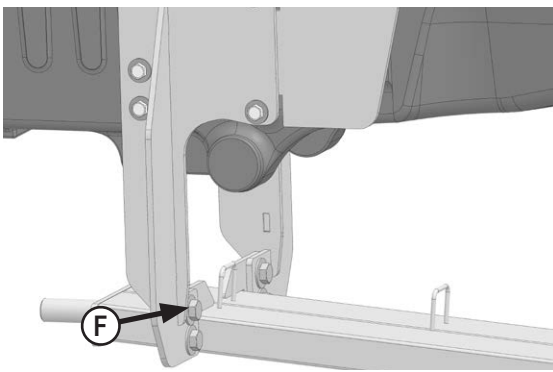

9. Attach side brackets to undercarriage with 4 - 1" x 2-1/2" bolts, 8 - 1" flat washers and 4 - 1" nuts (F).
10. Torque front 20mm bolts (C) to 432 ft-lbs.
11. Torque front 24mm bolts (D) to 909 ft-lbs.
12. Torque side rail 20mm bolts (E) to 432 ft-lbs.
13. Torque side rail 1" nuts (F) to 909 ft-lbs.
14. Position push pole under tractor.

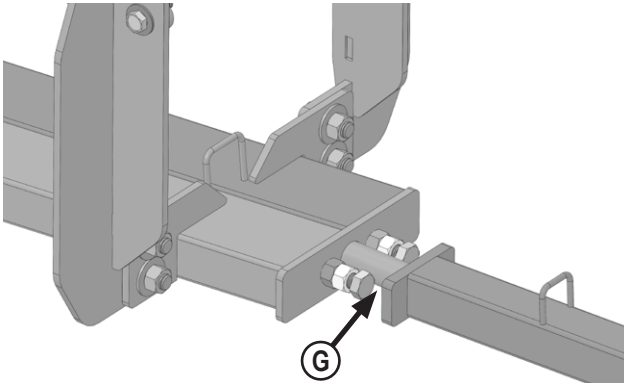

15. Slide front of push pole onto rod at rear of undercarriage (G).

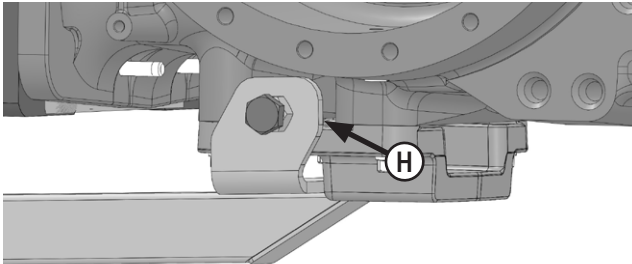

16. Raise rear of push pole up to drawbar bracket. Screw in 2 - 1" x 3" bolts fully into nuts at rear of push pole until tight and are resting on top of draw bar bracket (H).

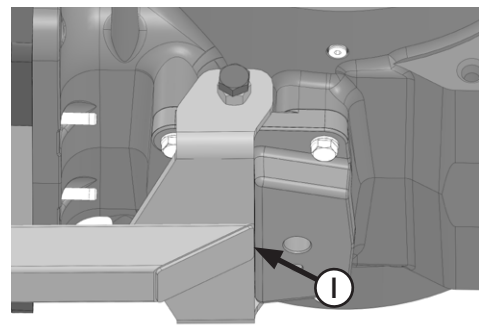

17. Push drawbar back tight against drawbar bracket (I).

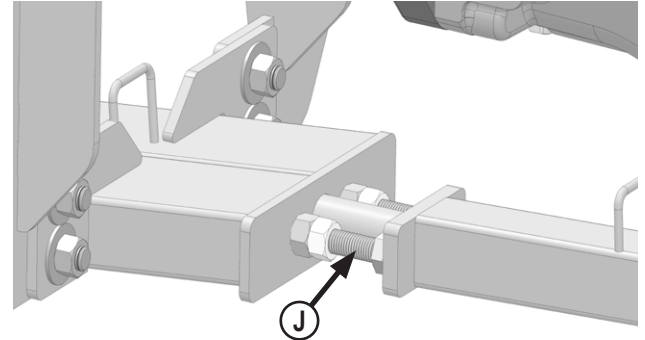

18. Evenly unscrew 1" x 6" bolts at front of push pole until tight against push pole. Torque 1" bolts to 90-95 ft-lbs (J).
19. Tighten 1" nuts up tight against undercarriage. Use nuts to lock the 1" bolts in place.

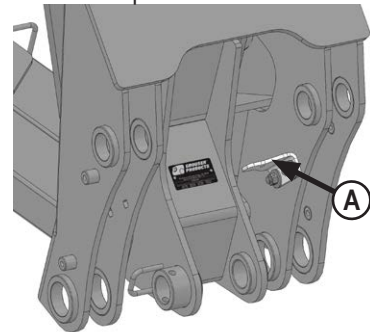

20. Reattach the hose clamp bracket (K) that was removed in Step #3.
21. Torque 1/2" nuts (K) to 75 ft-lbs.
22. Route hoses through hose loops on undercarriage and push pole to back of tractor.
23. Protect hoses around sharp corners and moving objects. Use zip ties to secure hoses in place.
24. Plug the hoses into open SCV's at rear of tractor.

Assembling Lift Components

1. Refer to the Blade Owner's Manual & Parts Book for instructions on how to assemble the lift components.

Maintenance

1. After first 8 hours of use, re-torque all bolts.
2. Check all fasteners regularly to ensure proper operation of equipment.
3. Inspect all equipment for existing or potential damages every 10 hours or less.

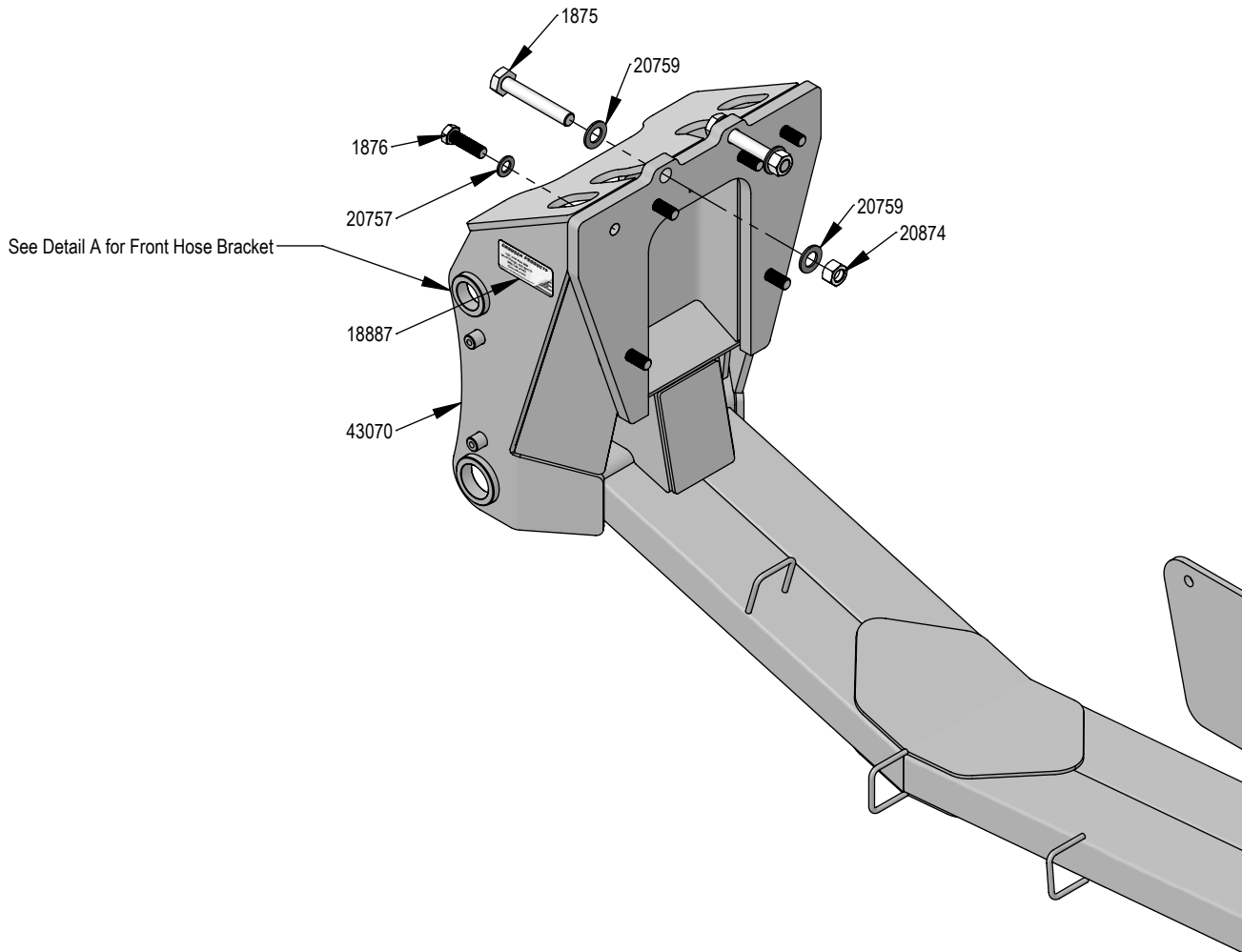

DETAIL A

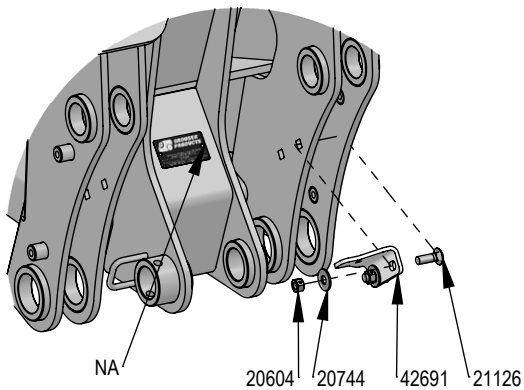

DETAIL B

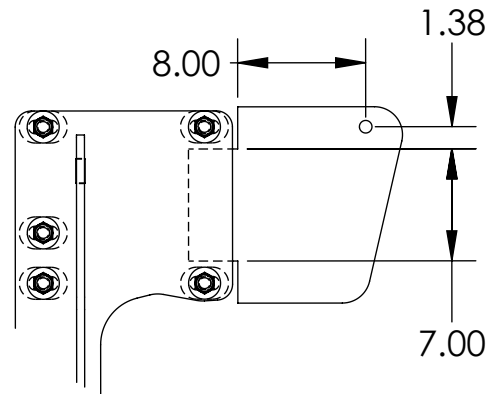

Modifications are needed for pad bolted to side of tractor frame. The rear holes on the pad need to be cut as shown above. Measurements are supplied as guidelines. Adjustments may be needed. Keep some material to fit between the spacers behind the supplied side brackets. The pad is still held on by one of the original bolts.

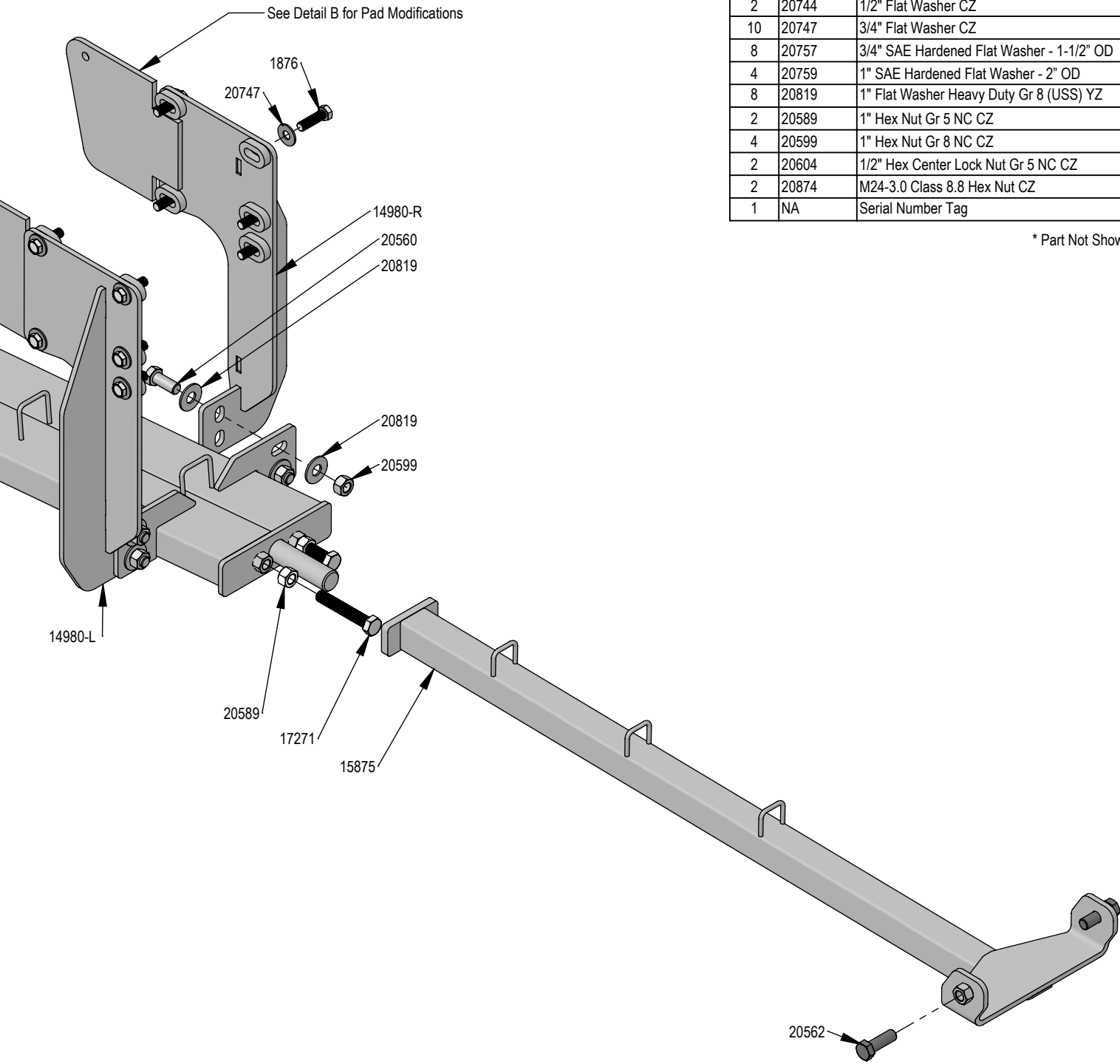

QTY.	PART NO.	DESCRIPTION
1	14980-L	Side Rail
1	14980-R	Side Rail
1	15875	Magnum T4 CVT Push Pole
2	17271	1" X 6" Hex Bolt Gr 8 NC (Full Thread)
2	1875	24mm x 3.00mm x 150mm Hex Bolt
16	1876	20mm x 2.5mm x 70mm Hex Bolt Gr 10.9
1	2489*	20mm x 2.5mm x 120mm Hex Bolt Gr 10.9
4	20560	1" X 2-1/2" Hex Bolt Gr 8 NC YZ
2	20562	1" X 3" Hex Bolt Gr 8 NC YZ
2	21126	1/2" x 1-1/2" Carriage Bolt Gr 5 NC CZ
1	18887	Made in America
1	42691	Hose Bracket
1	43070	FH-440 XR NH T8 Undercarriage - Susp. Axle
2	20744	1/2" Flat Washer CZ
10	20747	3/4" Flat Washer CZ
8	20757	3/4" SAE Hardened Flat Washer - 1-1/2" OD
4	20759	1" SAE Hardened Flat Washer - 2" OD
8	20819	1" Flat Washer Heavy Duty Gr 8 (USS) YZ
2	20589	1" Hex Nut Gr 5 NC CZ
4	20599	1" Hex Nut Gr 8 NC CZ
2	20604	1/2" Hex Center Lock Nut Gr 5 NC CZ
2	20874	M24-3.0 Class 8.8 Hex Nut CZ
1	NA	Serial Number Tag

* Part Not Shown

DWG. NO.: 43080-A

Notes

Notes

Improvements

Grouser Products Inc. is continually striving to improve its products. We reserve the right to change prices, specification, or equipment at any time without notice. We also reserve the right to make improvements or changes when it becomes practical and possible to do so without incurring any obligation to make changes or additions to the equipment sold previously.

Warranty

Grouser Products warrants to the original purchaser of each item that the product be free from defects in material and workmanship under normal use and service for a period of **two (2) years for Agriculture Series Blades and one (1) year for Heavy Duty Series from date of original retail delivery.**

The obligation of the consumer under this warranty:

1. To read the operators manual and to operate, lubricate, maintain and store equipment in accordance with the instructions listed in the operators manual.
2. To inspect equipment and if any part needs repair or replacement when continued use would cause damage or wear to other parts or safety.
3. All equipment or parts claimed to be defective in material or workmanship must be made available for inspection at the place of business of a dealer authorized to handle the equipment covered by this warranty, or, upon request by Grouser Products, shipped to the Grouser Products factory in West Fargo, North Dakota.

The obligation of the dealer under this warranty:

1. Complete warranty registration form and submit within 30 days of sale.
2. Contact Grouser Products for authorization prior to performing any warranty repairs or part replacement.
3. Complete warranty request form and submit with photos and supporting documentation.

The obligation of Grouser Products under this warranty:

1. Repair or replace, any equipment or parts, in the judgment of Grouser Products to be defective in material or workmanship.
2. Grouser Products will cover the cost of parts and ground shipping at dealer invoice only.
3. Grouser Products shall have no obligation to bear the cost of labor or transportation in connection with replacement or repair of any such defective parts.

This warranty does not cover:

1. Depreciation or damage caused by normal wear, accident, improper assembly, improper adjustments.
2. Improper maintenance including lack of proper lubrication, or improper use. Including loose bolts, nuts, or fitting due to over tightening or vibration after 20 hours of operation.
3. Repairs or alterations without authorization from a Grouser Products representative.
4. Grouser Products shall have no liability if the equipment has been altered or reworked without the written authorization of Grouser Products.

Grouser Products' parts, which are furnished under this warranty and properly installed, shall be warranted to the same extent as the original parts under this warranty if, and only if, such parts are found to be defective within the original warranty period covering the original equipment.

NO EMPLOYEE OR REPRESENTATIVE OF GROUSER PRODUCTS IS AUTHORIZED TO CHANGE THE WARRANTY IN ANY WAY OR GRANT ANY OTHER WARRANTY.

Contact Us

As always, if you have any questions about your system or other products made by Grouser, feel free to contact us.



755 2nd Ave NW - West Fargo, ND 58078
+1 701-282-7710 | info@grouser.com
www.grouser.com