



Case Steiger

Ag Pro Undercarriage

Installation Instructions

For Models:

Case Steiger Quad Tier 4A: 450, 500, 550, 600

Purchase Date
Serial Number
Model Number
Tractor Model
Dealer

To The Owner

This manual contains information concerning the installation of the undercarriage. You have purchased dependable, long lasting equipment, but only by proper care and operation can you expect to receive the performance and long service built into our products. Please have all operators read this manual carefully and keep the manual available for ready reference. If you have any questions or concerns, contact Grouser Products.

Caution:

- Always use caution when working around any equipment.
- Always wear safety glasses.
- Follow tractor manufacturer's safety guidelines when installing this product.
- Use paint where necessary to prevent rust.
- Do not modify or permit anyone else to modify or alter the equipment and its components without first consulting Grouser Products.
- Operate within your own capabilities. Recommended operating speed is 3-5 MPH (5-8 km/h).



Serial Number Location

Note:

- Read all instructions prior to performing installation.
- When installing hardware, only finger tighten until all hardware is in place.
- A full diagram of the assembly with the full list of parts is on pages 6-7.
- Tractor frame not shown in some diagrams for clarity.
- Unstrap and remove any components that are attached for shipping.



To ensure the safety of those working under and around the machine, apply parking brake, and remove key from ignition before working on the machine.

Installation

1. If applicable, remove bumper, front weights, weight bracket, toolboxes and tow cable holder. If tow cable kit was purchased from Grouser, the tow cable will be reinstalled in a later step.
2. Remove upper support arms and side plates from undercarriage to make room for installing undercarriage on the tractor and unscrew vertical 1" bolts at rear of undercarriage.

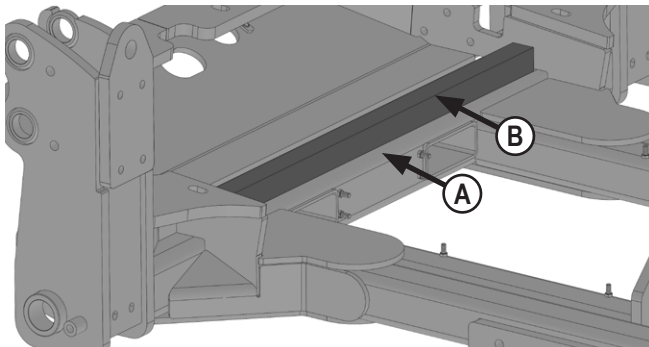

3. Clean top of undercarriage tube (A). Cut foam (B) to 45".
4. Peel off transfer tape from side of foam. Center foam (B) from side to side and 1" forward on top of tube on undercarriage (A).
5. Press down firmly on foam to securely adhere foam to undercarriage.

6. Position undercarriage under tractor and center on tractor frame.

NOTE: When lifting undercarriage, watch for potential pinching of hoses or any other components to prevent damage.

NOTE: When lifting undercarriage, watch foam location to prevent damage to foam.

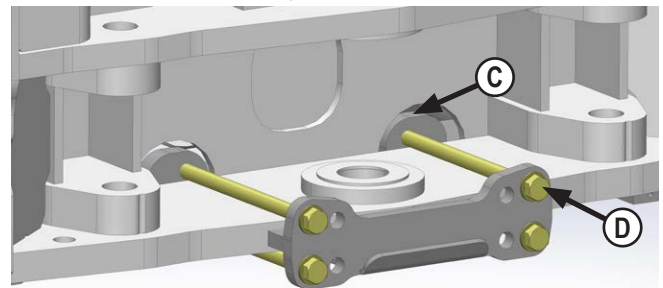

7. Lift undercarriage and push undercarriage back until vertical push plates (C) are firmly against cross member and all 4 holes are exposed.
8. At rear of undercarriage and pivot area of tractor, attach rear clamp bracket to undercarriage with 4 - 3/4" x 13" bolts and 4 - 3/4" hardened washers (D). **Use outer 4 holes on bracket.** Center bracket and tighten bolts until snug.

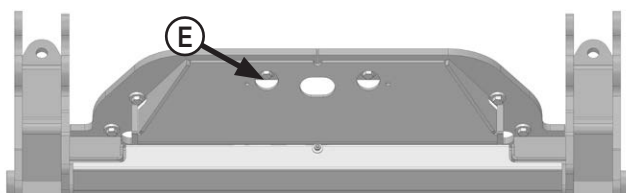

- At front of undercarriage, install 8 - 20mm x 90mm bolts, 6 - 3/4" ID x .375" thick washers, 8 - 3/4" flat washers and 8 - 20mm nuts in front vertical slots (E). Use a 7/8" clipped washer on the rear bolt on each side.

NOTE: See Page 6-7 for proper orientation of hardware.

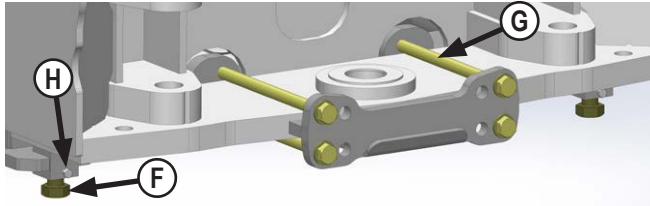

- Tighten rear vertical bolts evenly (F) to pull rear of undercarriage down until 3/4" x 13" bolts are resting on top of tractor cross member (G).
- Torque 3/4" bolts on the rear bracket to 380 ft-lbs (D).
- Torque rear vertical 1" bolts to 100 ft-lbs (F).
- Install 2 - 5/16" x 3/4" bolts into blocks at rear of undercarriage to lock each 1" bolt in place (H). Torque 5/16" bolts to 19 ft-lbs.

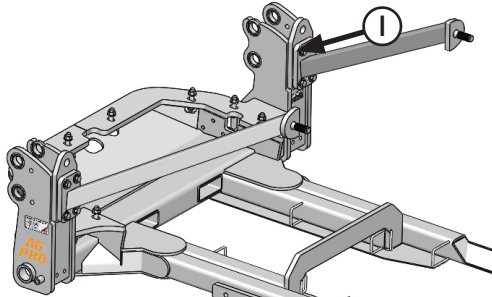

- Attach front upper support arms to undercarriage with 8 - 3/4" x 2-1/2" bolts and 8 - 3/4" hardened flat washers (I).

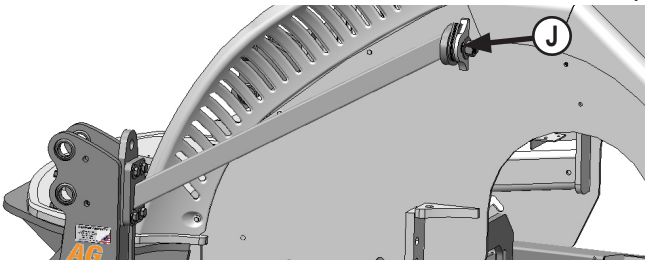

- Attach front upper support arms to tractor with 2 - 1-1/4" flat washers and 2 - 1-1/4" nuts (J).

NOTE: Add shims between support arm and tractor frame to reduce any gap if necessary. Use shims until there is a gap less than 1/16".

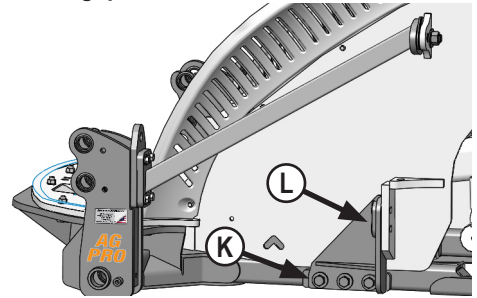

- Remove 24mm bolts and spacers from front axle on both sides of tractor. Discard spacers.
- Attach yoke brackets to undercarriage with 6 - 1" x 2-1/2" bolts and 6 - 1" ID x .375" thick washers (K).
- Dip previously removed 24mm bolts in W30 oil and attach yoke brackets to tractor frame with 4 - 24mm bolts and 4 - 1" flat heavy washers (L).
- Torque front vertical 20mm bolts to 432 ft-lbs (E).

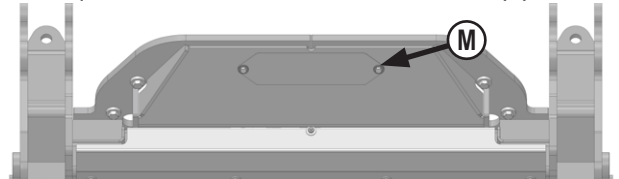

- Attach front cover plate to undercarriage with 2 - 1-1/2" x 1-1/4" bolts and 2 - 1/2" washers (M).
- Torque upper support arm 3/4" bolts to 380 ft-lbs (I).
- Torque upper support arm 1-1/4" nuts to 1,105 ft-lbs (J).
- Torque original 24mm bolts to 555 ft-lbs (L).
- Torque yoke bracket 1" bolts to 903 ft-lbs (K).

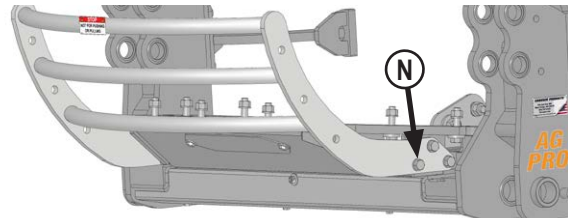

- Install grill guard to front of undercarriage with 6 - 3/4" x 1-3/4" bolts and 6 - 3/4" flat washers (N).
- Torque 3/4" bolts to 257 ft-lbs (N).

NOTE: If applicable, refer to Page 5 to attach front of tow cable.

Hose Routing

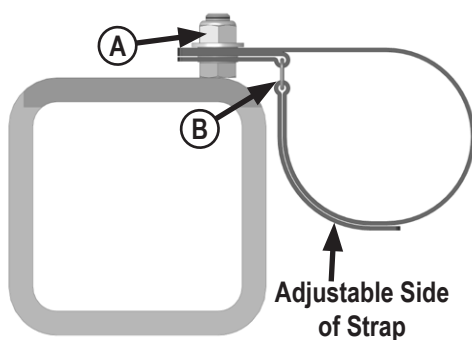

- Attach a velcro hose strap on every bolt along undercarriage with a 3/8" flange nyloc nut (A). Assemble strap with the metal loop on bottom side as shown (B). Keep straps open.

NOTE: Orientation of velcro strap is important and is shown in photo.

NOTE: Quantity of hoses is dependent on which blade system is being used.

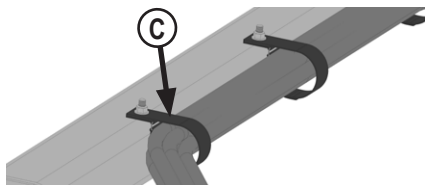

2. Route hoses along undercarriage tubes and secure with velcro straps (C).

NOTE: While grouping hoses together, do not cross hoses over each.

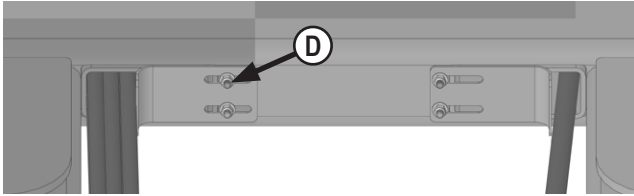

3. Attach hose cover plates to undercarriage with 4 - 3/8" flange nyloc nuts (D). Slide plates until snug against hoses and tighten nuts.

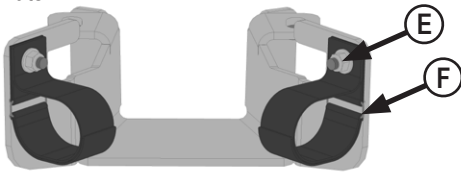

4. Secure hose straps to bottom cover plate with 3/8" x 1" carriage bolts and 3/8" flange nyloc nuts (E). Attach strap with metal loop on bottom side of strap (F). Keep straps open until securing hoses.

NOTE: While grouping hoses together, do not cross hoses over each.

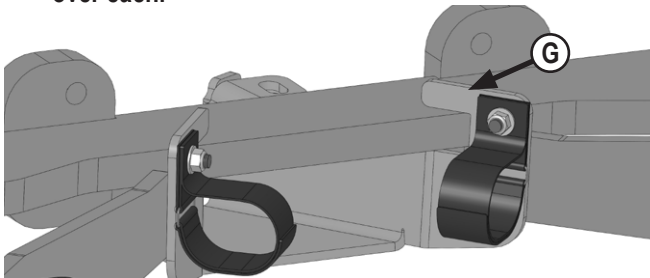

5. Lift bottom cover plate into place with hoses between cover plate and bottom of undercarriage. Set cover plate on rear cross member of undercarriage (G).

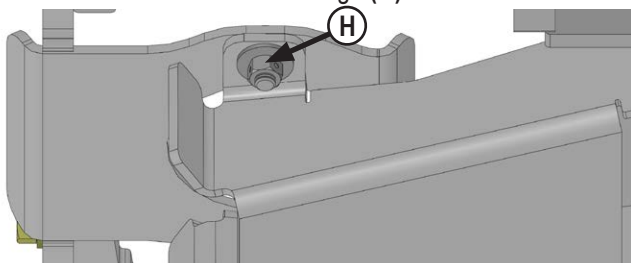

6. Attach bottom cover plate to rear clamp bracket with 2 - 1/2" flat washers, and 2 - 1/2" lock nuts (H).

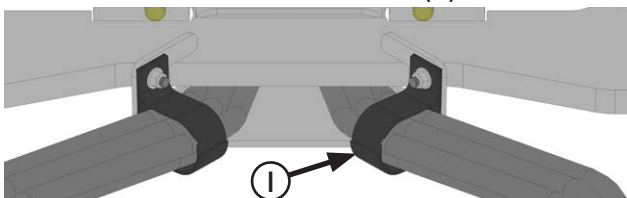

7. Continue routing hoses through cover plate. Secure hoses with velcro straps (I).

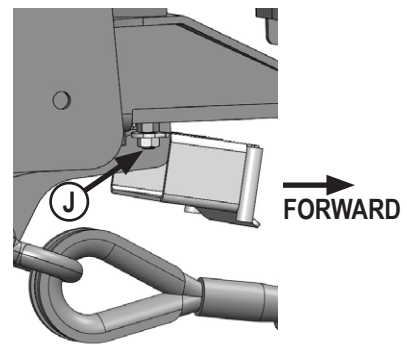

8. Gather and position hoses inside hose routing bracket. Raise rear hose routing bracket with hoses and attach to 20mm bolts located at front of rear tractor frame behind pivot area. Attach with 2 - 20mm nuts (J). Ensure lip of bracket is facing towards front of tractor.

9. Torque the 20mm nuts to 432 ft-lbs (J).

NOTE: Refer to diagram at top of Page 5 if clarification is needed for Step #10-15.

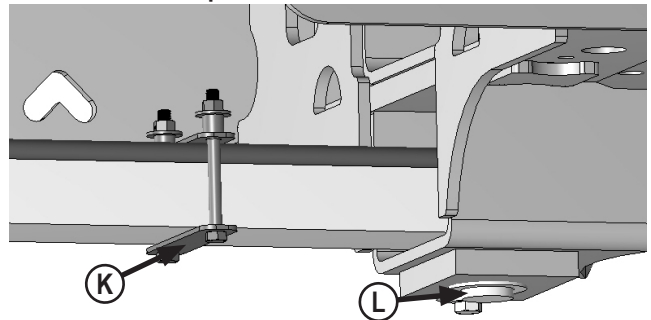

10. Position hoses on top of drawbar and secure with 4- hose holding plates, 4 - 1/2" x 5-1/2" or 6" bolts, and 4 - 1/2" nuts.

11. Place front holding plates (K) 12" from center of drawbar pin at front of drawbar (L).

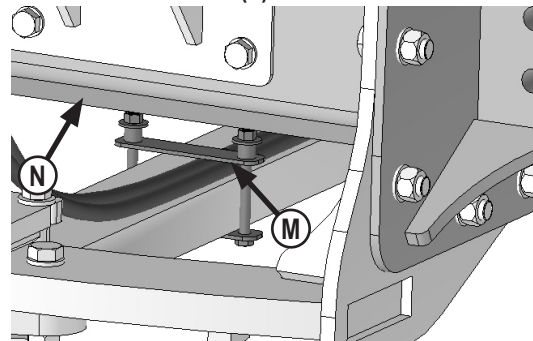

12. Place rear holding plates (M) half-way between rear axle and rear tractor frame (N).

NOTE: Before tightening any bolts, turn and articulate tractor to provide slack in hoses at pivot point.

NOTE: When tightening the 1/2" nuts, do not crush the hoses.

13. Tighten hardware on drawbar hose holding plates until plates are firmly against hoses without deforming hoses. Use 3/4" spacers and 1/2" washers on top plate if needed to provide enough thread to tighten.

14. Insert couplers in open SCV's at back of tractor.

15. Perform an articulation check to make sure hoses do not get pulled when fully articulated. Make adjustments and allow adequate slack if necessary.

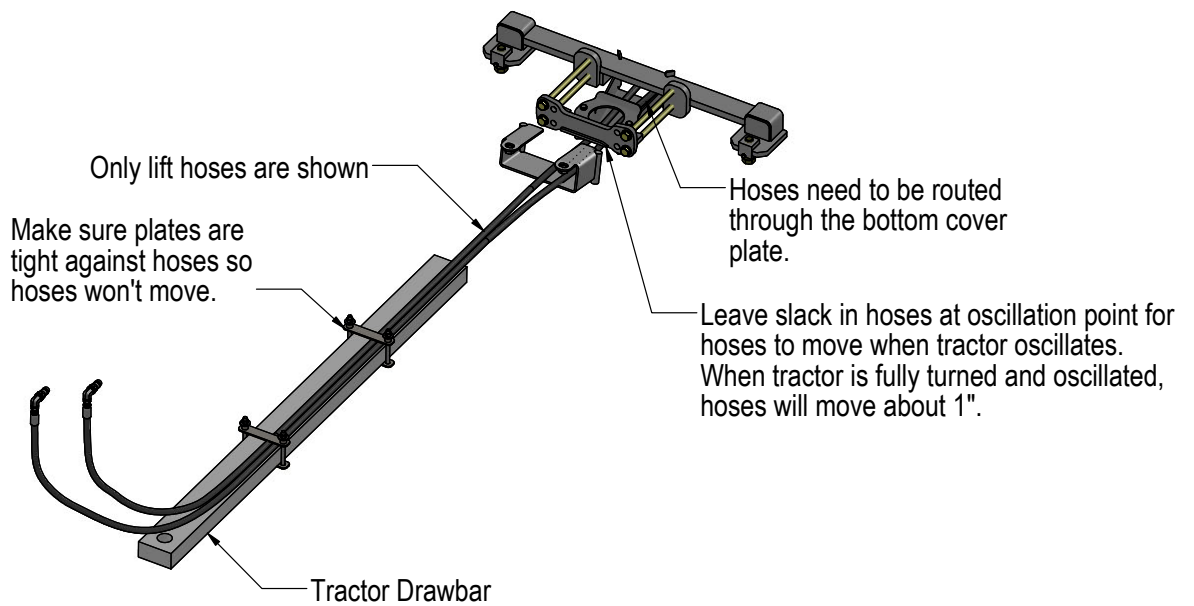

Assembling Lift Components



1. Refer to the Blade Owner's Manual & Parts Book for instructions on how to assemble the lift components.
2. When installing hydraulics on top arms, group hoses together with velcro strap. Attach velcro strap to multi-coupler bracket with a 3/8" x 1" carriage bolt and a 3/8" flange nyloc nut (A).

Maintenance

1. After first 8 hours of use, re-torque all bolts.
2. Check all fasteners regularly to ensure proper operation of equipment.
3. Inspect all equipment for existing or potential damages every 10 hours or less.
4. Inspect hoses at articulation point and around lift system. Check for any abrasion or damage to hoses.

Tow Cable Support Bracket Assembly

NOTE: Kit is required if tractor has a tow cable.

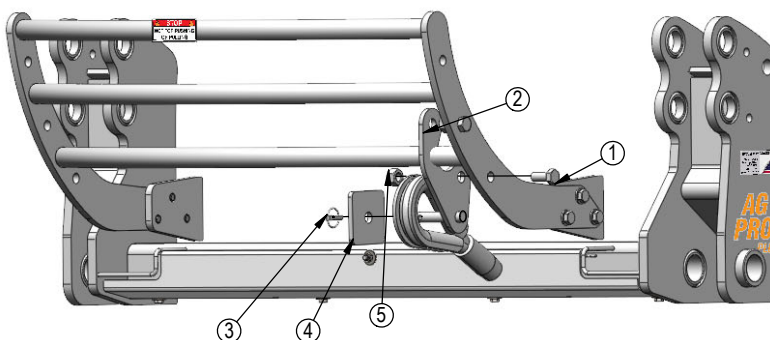

Tow Cable Support Bracket Assy - 18-41788-A			
ITEM NO.	QTY.	PART NO.	DESCRIPTION
1	2	16-20538	7/8" x 2" Hex Bolt Gr 8 NC
2	1	18-41788	Tow Cable Bracket
3	1	43-16764	7/16" x 1-3/4" Lynch Pin
4	1	44-15585	Plate
5	2	70-20598	7/8" Hex Nut Gr 8 NC

See Detail A

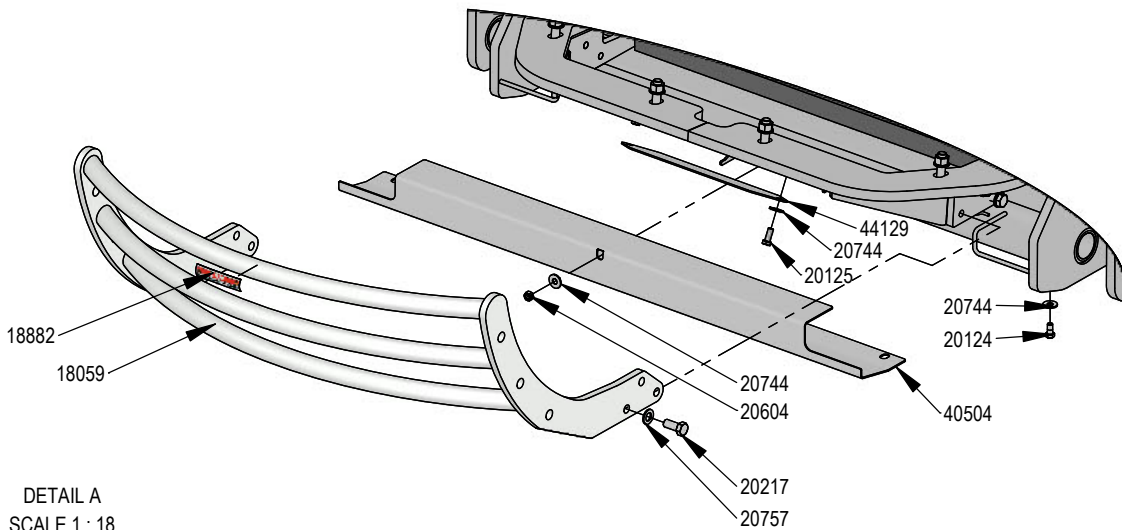
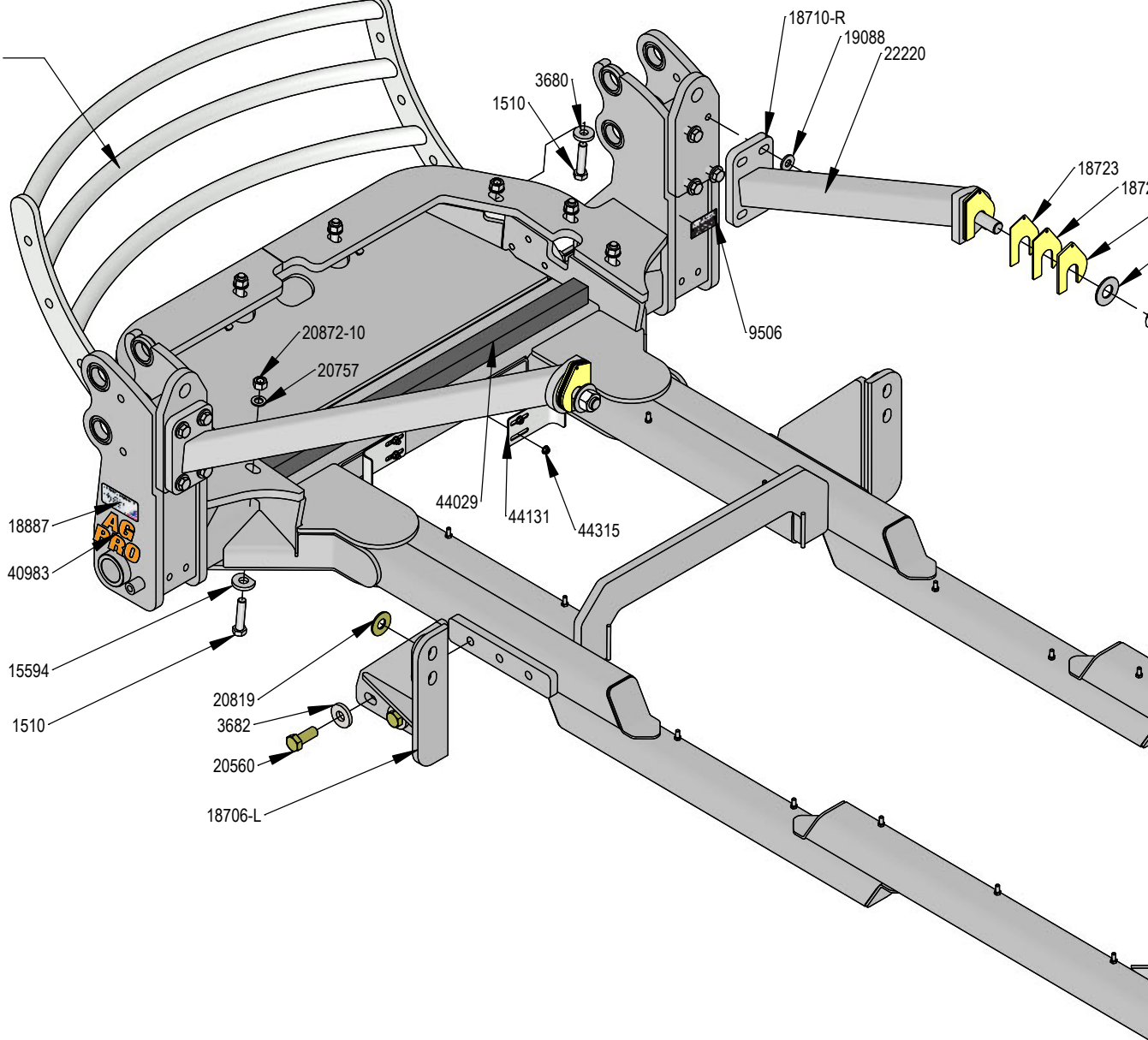

DETAIL A
SCALE 1 : 18

Note: Some parts not shown for clarity

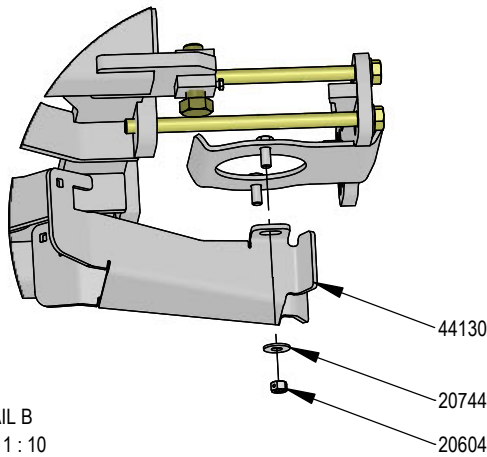

QTY.	PART NO.	DESCRIPTION
2	11671	1-1/4" Flat Washer CZ
8	1510	20mm x 2.5mm x 90mm Hex Bolt Gr 10.9
4	15528	Round Tube
2	15594	7/8" ID x 2-1/4" OD x .375" Heavy Washer CZ Plated
4	17245	Plate
1	18059	Grill Guard Weld
1	18706-L	Bracket, Yoke
1	18706-R	Bracket, Yoke
1	18710-L	Support Arm, Quad (T4A)
1	18710-R	Support Arm, Quad (T4A)
4	18721	Support Arm Shim, .25"
4	18722	Support Arm Shim, .125"
4	18723	Support Arm Shim, .063"
1	18882	Not For Pushing or Pulling Decal
1	18887	Made in 'Merica
8	19088	3/4" x 1.68" x .18" HD Washer YZ
2	20032	5/16" X 3/4" Hex Bolt Gr 5 NC CZ
4	20124	1/2" X 1" Hex Bolt Gr 5 NC CZ
2	20125	1/2" X 1-1/4" Hex Bolt Gr 5 NC CZ
4	20139	1/2" X 5-1/2" Hex Bolt Gr 5 NC CZ
4	20140*	1/2" x 6" Hex Bolt Gr 5 NC CZ
6	20217	3/4" X 1 3/4" Hex Bolt Gr 5 NC CZ
6	20560	1" X 2-1/2" Hex Bolt Gr 8 NC YZ
2	20562	1" X 3" Hex Bolt Gr 8 NC YZ
7	20604	1/2" Hex Center Lock Nut Gr 5 NC CZ
13	20744	1/2" Flat Washer CZ
18	20757	3/4" SAE Hardened Flat Washer - 1-1/2" OD
4	20819	1" Flat Washer Heavy Duty Gr 8 (USS) YZ
10	20872-10	M20-2.5 Class 10.9 Hex Nut CZ
2	20981	1-1/4" Hex Nut Gr 5 NC CZ
8	22220	3/4" X 2-1/2" Hex Bolt Gr 8 NC YZ
6	3680	0.75" ID x 2.00" OD x .375" Heavy Washer
6	3682	1.00" ID x 2.50" OD x .375" Heavy Washer
1	40504	Plate, Cover
1	40518	Hose Routing Bracket
2	40983	Ag Pro
1	44029	Foam Seal
1	44120	CNH Wide Frame Undercarriage Weld
1	44125	CNH Rear Clamp
1	44129	Plate, Front Cover
1	44130	CNH Bottom Hose Bracket
2	44131	Plate, Hose Cover
4	44132	3/4" X 13" Hex Bolt Gr 8 NC YZ
4	44315	3/8" Nyloc Flange Nut Gr N5 NC
1	9506	

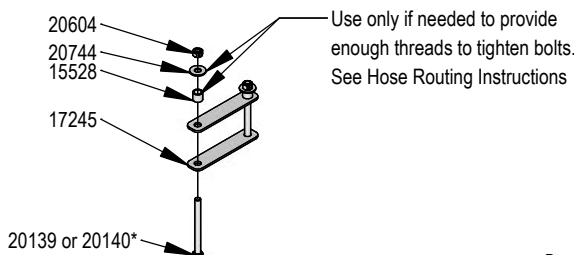
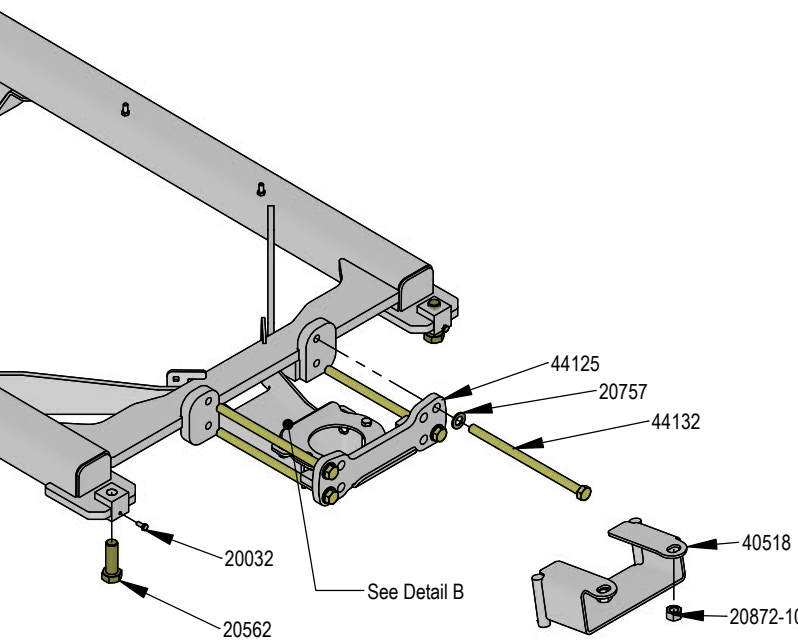

* Only Used with Sliding Blade System

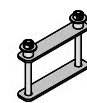

DWG. NO.: 44135-A

Improvements

Grouser Products Inc. is continually striving to improve its products. We reserve the right to change prices, specification, or equipment at any time without notice. We also reserve the right to make improvements or changes when it becomes practical and possible to do so without incurring any obligation to make changes or additions to the equipment sold previously.

Warranty

Grouser Products warrants to the original purchaser of each item that the product be free from defects in material and workmanship under normal use and service for a period of **two (2) years for Agriculture Series Blades and one (1) year for Heavy Duty Series from date of original retail delivery.**

The obligation of the consumer under this warranty:

1. To read the operators manual and to operate, lubricate, maintain and store equipment in accordance with the instructions listed in the operators manual.
2. To inspect equipment and if any part needs repair or replacement when continued use would cause damage or wear to other parts or safety.
3. All equipment or parts claimed to be defective in material or workmanship must be made available for inspection at the place of business of a dealer authorized to handle the equipment covered by this warranty, or, upon request by Grouser Products, shipped to the Grouser Products factory in West Fargo, North Dakota.

The obligation of the dealer under this warranty:

1. Complete warranty registration form and submit within 30 days of sale.
2. Contact Grouser Products for authorization prior to performing any warranty repairs or part replacement.
3. Complete warranty request form and submit with photos and supporting documentation.

The obligation of Grouser Products under this warranty:

1. Repair or replace, any equipment or parts, in the judgment of Grouser Products to be defective in material or workmanship.
2. Grouser Products will cover the cost of parts and ground shipping at dealer invoice only.
3. Grouser Products shall have no obligation to bear the cost of labor or transportation in connection with replacement or repair of any such defective parts.

This warranty does not cover:

1. Depreciation or damage caused by normal wear, accident, improper assembly, improper adjustments.
2. Improper maintenance including lack of proper lubrication, or improper use. Including loose bolts, nuts, or fitting due to over tightening or vibration after 20 hours of operation.
3. Repairs or alterations without authorization from a Grouser Products representative.
4. Grouser Products shall have no liability if the equipment has been altered or reworked without the written authorization of Grouser Products.

Grouser Products' parts, which are furnished under this warranty and properly installed, shall be warranted to the same extent as the original parts under this warranty if, and only if, such parts are found to be defective within the original warranty period covering the original equipment.

NO EMPLOYEE OR REPRESENTATIVE OF GROUSER PRODUCTS IS AUTHORIZED TO CHANGE THE WARRANTY IN ANY WAY OR GRANT ANY OTHER WARRANTY.

Contact Us

As always, if you have any questions about your system or other products made by Grouser, feel free to contact us.



755 2nd Ave NW - West Fargo, ND 58078
+1 701-282-7710 | info@grouser.com
www.grouser.com