



JOHN DEERE 9000, 9020

Ag Pro Undercarriage

Installation Instructions

For Models:

JD 9000, 9020: 9100, 9200, 9300, 9400, 9120, 9220, 9320, 9420, 9520, 9620

Purchase Date
Serial Number
Model Number
Tractor Model
Dealer

To The Owner

This manual contains information concerning the installation of the undercarriage. You have purchased dependable, long lasting equipment, but only by proper care and operation can you expect to receive the performance and long service built into our products. Please have all operators read this manual carefully and keep the manual available for ready reference. If you have any questions or concerns, contact Grouser Products.

Caution:

- Always use caution when working around any equipment.
- Always wear safety glasses.
- Follow tractor manufacturer's safety guidelines when installing this product.
- Use paint where necessary to prevent rust.
- Do not modify or permit anyone else to modify or alter the equipment and its components without first consulting Grouser Products.

Note:

- When installing hardware, only finger tighten until all hardware is in place.
- A full diagram of the assembly with the full list of parts is on pages 4-5.
- Unstrap and remove any components that are attached for shipping.
- Read all instructions prior to performing installation.
- Tractor frame not shown in some diagrams for clarity.

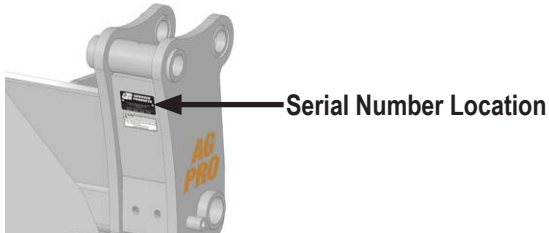

Serial Number Location

Installation

1. If applicable, remove front weights, weight bracket, toolbox and front axle brace from front of tractor.
2. If necessary, drill out front holes on each side frame rail on the tractor for 7/8" bolts. Refer to picture below for clarification of which holes will be used.
3. Position undercarriage under tractor and center on the frame of the tractor. Lift undercarriage until holes of undercarriage line up with holes in the side of the tractor frame.

NOTE: When lifting the undercarriage, watch for any potential pinching of hoses or any other components to prevent any damage.

NOTE: Add shims between the undercarriage and the tractor frame to reduce any gap if necessary. Use shims until there is a gap of 1/16" or less on the front. See attached diagram for the proper location and orientation of each shim. Do Not put all of the shims on one side of the undercarriage. For the first holes on each side, use a 78" flat washer as a shim, if necessary.

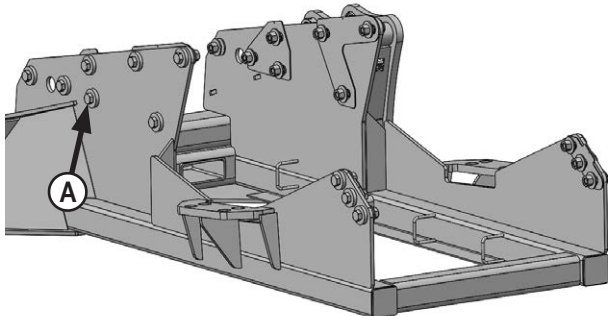

4. Install 20 - 7/8" x 3" bolts, 20 - 7/8" ID thick washers, shims if necessary, 20 - 7/8" flat washers and 20 - 7/8" nuts through the side holes on the undercarriage and tractor frame (A).

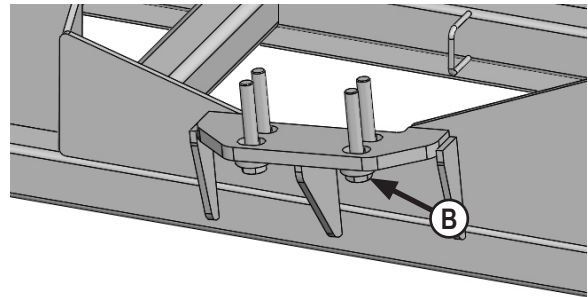

5. Install 8 - 24mm x 150mm bolts and 8 - 1" ID washers into vertical holes on axle. Flat sides of washers should meet for proper clearance (B).
6. Torque the 7/8" bolts (A) to 600 ft-lbs.
7. Torque the 24mm axle bolts (B) to 909 ft-lbs.

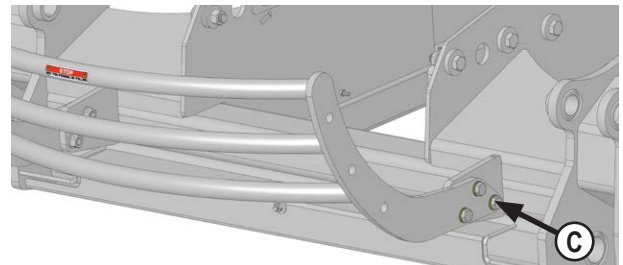

8. Install the grill guard to the front of the undercarriage with 6 - 3/4" x 2-1/2" bolts, 12 - 3/4" flat washers and 6 - 3/4" nuts (C).
9. Torque the 3/4" bolts (C) to 257 ft-lbs.

Hose Routing

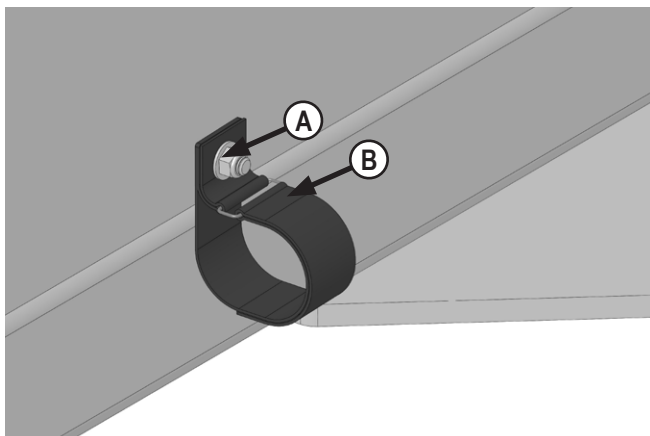

1. Attach a velcro strap on front bolt with a 3/8" flange nyloc nut (A). Assemble strap with the metal loop on top side as shown (B). Keep straps open.

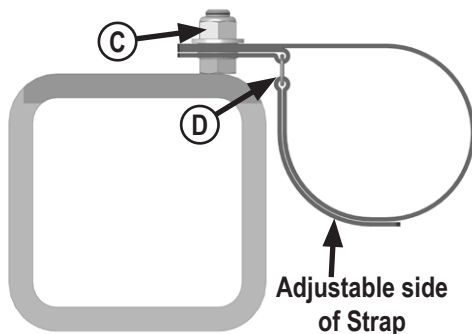

2. Attach a velcro hose strap on every bolt along tubes on undercarriage with a 3/8" flange nyloc nut (C). Assemble strap with the metal loop on bottom side as shown (D). Keep straps open.

NOTE: Orientation of velcro strap is important and is shown in above photos.

NOTE: Quantity of hoses is dependent on which blade system is being used.

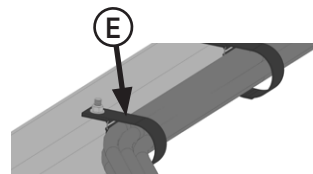

3. Route hoses along undercarriage tubes and secure with velcro straps (E).

NOTE: While grouping hoses together, do not cross hoses over each.

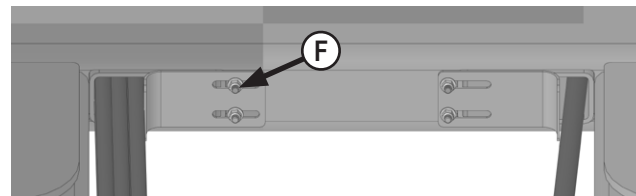

4. Attach hose cover plates to undercarriage with 4 - 3/8" flange nyloc nuts (F). Slide plates until snug against hoses and tighten nuts.

NOTE: Some parts on undercarriage are not shown for clarity.

Assembling Lift Components

1. Refer to the Blade Owner's Manual & Parts Book for instructions on how to assemble the lift components.

Maintenance

1. After first 8 hours of use, re-torque all bolts.
2. Check all fasteners regularly to ensure proper operation of equipment.
3. Inspect all equipment for existing or potential damages every 10 hours or less.

PART NO.	QTY.	DESCRIPTION
11849	2	Plate, Rear
17748	2	Plate, Front
17749	2	Plate, Middle
18059	1	Grill Guard Weld
1875	8	24mm x 3.00mm x 150mm Hex Bolt
18882	1	Not For Pushing or Pulling Decal
18887	1	Made in 'Merica
20124	4	1/2" X 1" Hex Bolt Gr 5 NC CZ
20220	6	3/4" X 2-1/2" Hex Bolt Gr 5 NC CZ
20542	20	7/8" X 3" Hex Bolt Gr 8 NC YZ
20598	20	7/8" Hex Nut Gr 8 NC CZ
20604	1	1/2" Hex Center Lock Nut Gr 5 NC CZ
20607	6	3/4" Hex Center Lock Nut Gr 5 NC CZ
20744	5	1/2" Flat Washer CZ
20757	12	3/4" SAE Hardened Flat Washer - 1-1/2" OD
20818	22	7/8" Flat Washer Heavy Duty Gr 8 (USS) YZ
3098	8	1.05" ID x 2.50" OD - JD Axle Mount Washer
40504	1	Plate, Cover
40962	1	Warning Prop 65 Decal
40983	2	Ag Pro
44131	2	Plate, Hose Cover
44315	4	3/8" Nyloc Flange Nut Gr N5 NC
44575	1	Undercarriage Weld
8836	20	7/8" x 2-1/2" x 1/2" Flat Washer
NA	1	Serial Number Tag

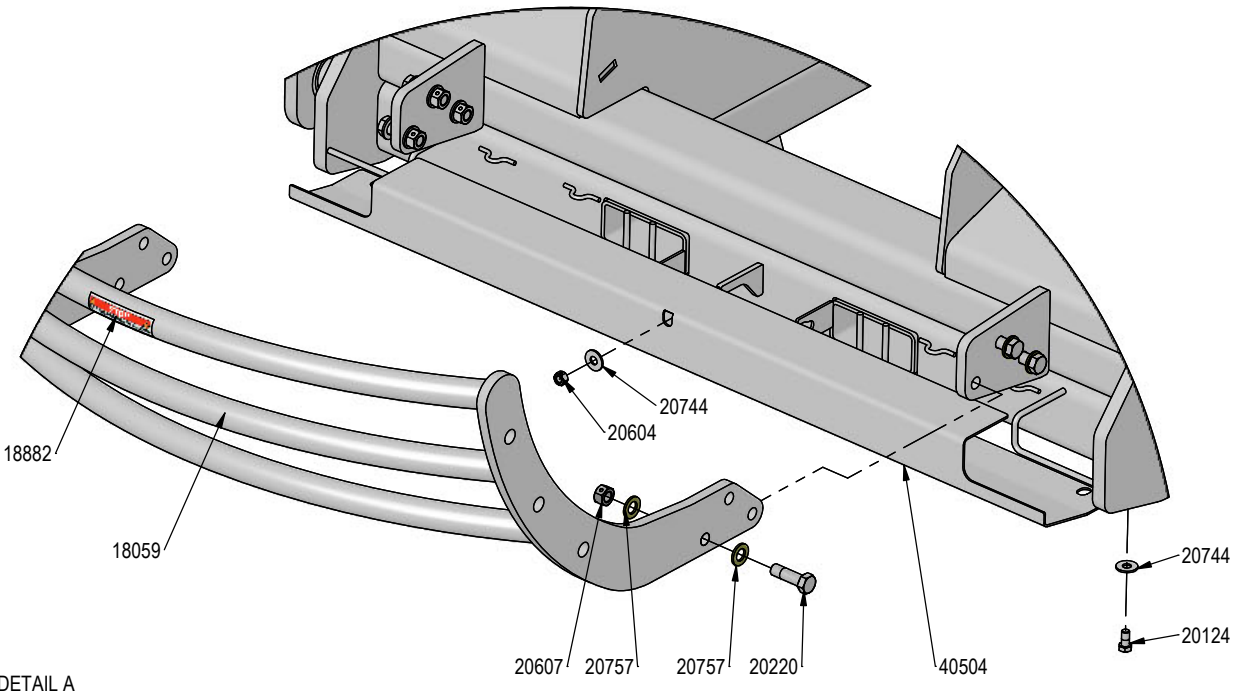
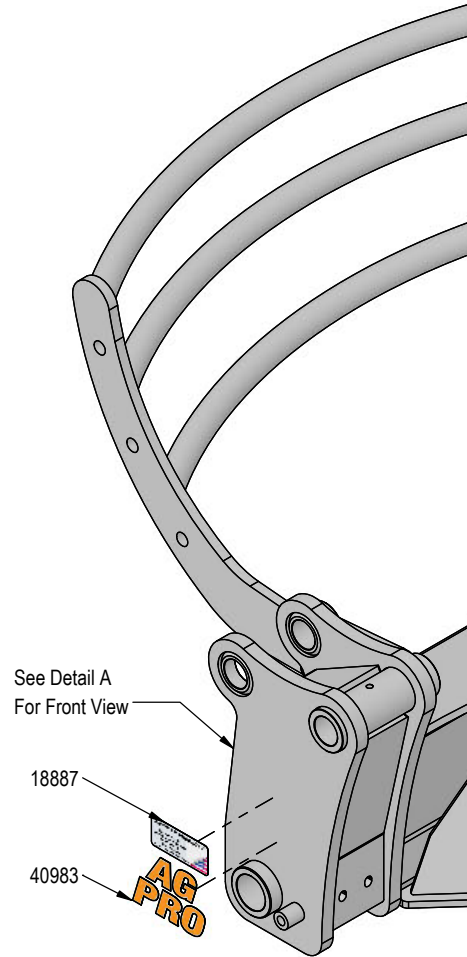

DETAIL A

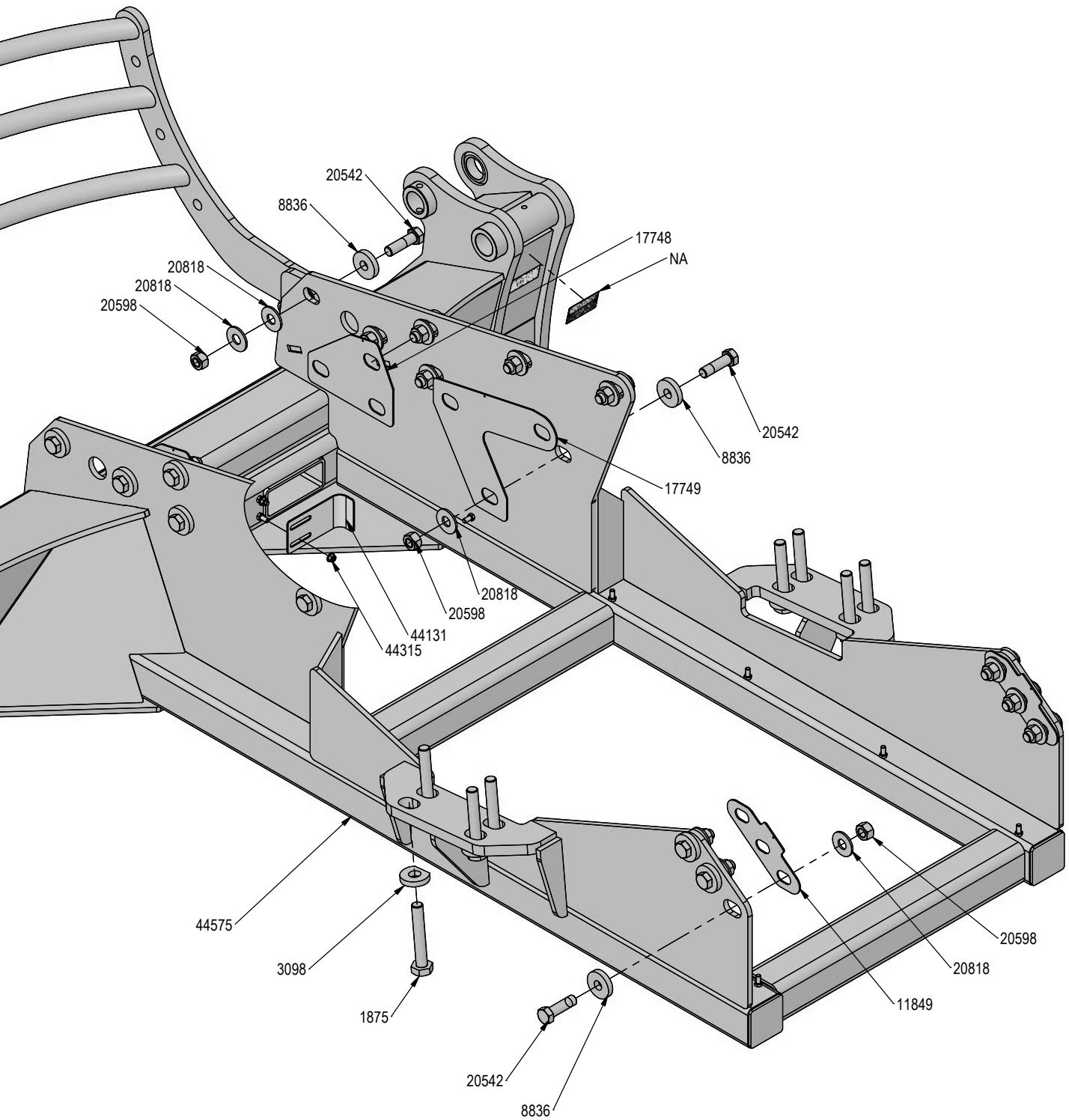

DWG. NO.: 44575-A

Improvements

Grouser Products Inc. is continually striving to improve its products. We reserve the right to change prices, specification, or equipment at any time without notice. We also reserve the right to make improvements or changes when it becomes practical and possible to do so without incurring any obligation to make changes or additions to the equipment sold previously.

Warranty

Grouser Products warrants to the original purchaser of each item that the product be free from defects in material and workmanship under normal use and service for a period of **two (2) years for Agriculture Series Blades and one (1) year for Heavy Duty Series from date of original retail delivery.**

The obligation of the consumer under this warranty:

1. To read the operators manual and to operate, lubricate, maintain and store equipment in accordance with the instructions listed in the operators manual.
2. To inspect equipment and if any part needs repair or replacement when continued use would cause damage or wear to other parts or safety.
3. All equipment or parts claimed to be defective in material or workmanship must be made available for inspection at the place of business of a dealer authorized to handle the equipment covered by this warranty, or, upon request by Grouser Products, shipped to the Grouser Products factory in West Fargo, North Dakota.

The obligation of the dealer under this warranty:

1. Complete warranty registration form and submit within 30 days of sale.
2. Contact Grouser Products for authorization prior to performing any warranty repairs or part replacement.
3. Complete warranty request form and submit with photos and supporting documentation.

The obligation of Grouser Products under this warranty:

1. Repair or replace, any equipment or parts, in the judgment of Grouser Products to be defective in material or workmanship.
2. Grouser Products will cover the cost of parts and ground shipping at dealer invoice only.
3. Grouser Products shall have no obligation to bear the cost of labor or transportation in connection with replacement or repair of any such defective parts.

This warranty does not cover:

1. Depreciation or damage caused by normal wear, accident, improper assembly, improper adjustments.
2. Improper maintenance including lack of proper lubrication, or improper use. Including loose bolts, nuts, or fitting due to over tightening or vibration after 20 hours of operation.
3. Repairs or alterations without authorization from a Grouser Products representative.
4. Grouser Products shall have no liability if the equipment has been altered or reworked without the written authorization of Grouser Products.

Grouser Products' parts, which are furnished under this warranty and properly installed, shall be warranted to the same extent as the original parts under this warranty if, and only if, such parts are found to be defective within the original warranty period covering the original equipment.

NO EMPLOYEE OR REPRESENTATIVE OF GROUSER PRODUCTS IS AUTHORIZED TO CHANGE THE WARRANTY IN ANY WAY OR GRANT ANY OTHER WARRANTY.

Contact Us

As always, if you have any questions about your system or other products made by Grouser, feel free to contact us.



755 2nd Ave NW - West Fargo, ND 58078
+1 701-282-7710 | info@grouser.com
www.grouser.com