

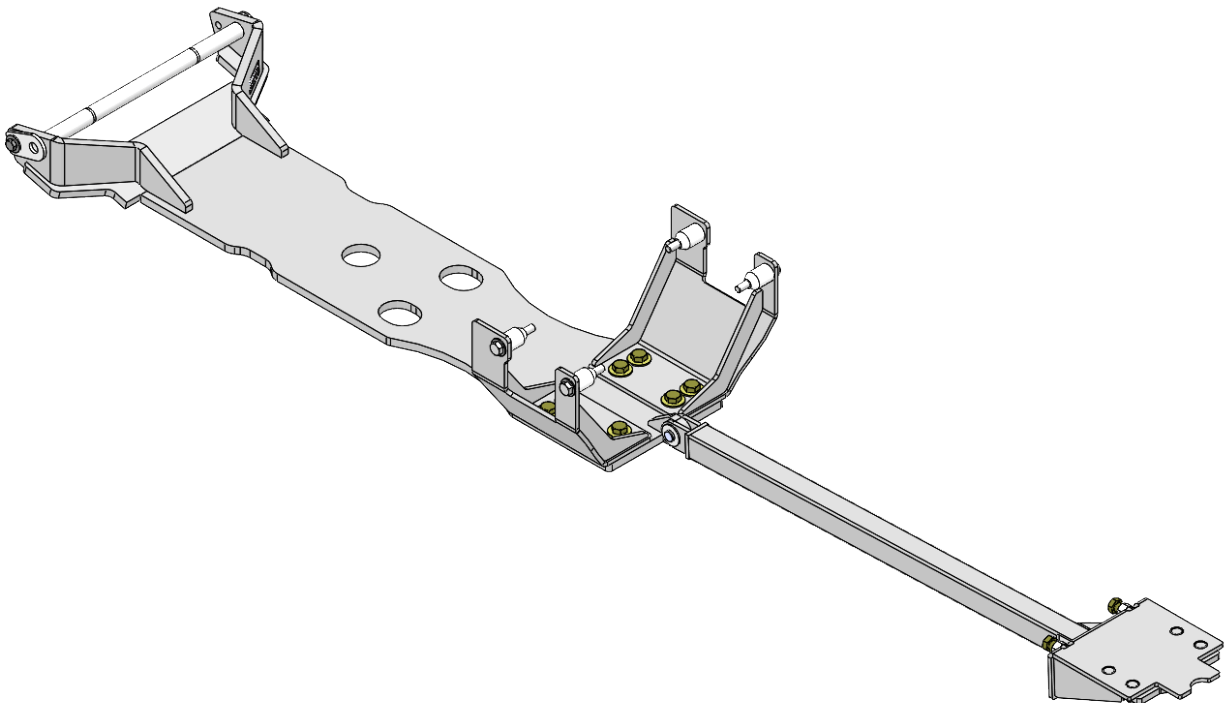

Agco DTb, Challenger & Massey 8600, 8700 & 8700S OEM Front 3-Point Hitch Support Installation Instructions



For Models:

Agco DT: DT205B, DT225B, DT250B, DT275B

Challenger: MT645C, MT655C, MT665C, MT675C, MT645D, MT655D, MT665D, MT675D

Massey: 8650, 8660, 8670, 8680, 8690, 8727, 8730, 8732, 8735, 8737, 8727S, 8730S, 8732S, 8735S, 8737S, 8740S, MT645C

Purchase Date
Serial Number
Model Number
Tractor Model
Dealer

To The Owner

This manual contains information concerning the installation of the front support. You have purchased dependable, long lasting equipment, but only by proper care and operation can you expect to receive the performance and long service built into our products. Please have all operators read this manual carefully and keep the manual available for ready reference. If you have any questions or concerns, contact Grouser Products.

Caution:

- Always use caution when working around any equipment.
- Always wear safety glasses.
- Follow tractor manufacturer's safety guidelines when installing this product.
- Use paint where necessary to prevent rust.
- Do not modify or permit anyone else to modify or alter the equipment and its components without first consulting Grouser Products.

Note:

- When installing hardware, only finger tighten until all hardware is in place.
- A full diagram of the assembly with the full list of parts is on pages 4-5.
- Unstrap and remove any components that are attached for shipping.
- Read all instructions prior to performing installation.

 To ensure the safety of those working under and around the machine, apply parking brake, remove key from ignition, and block tires before working on the machine.



Pre-Installation

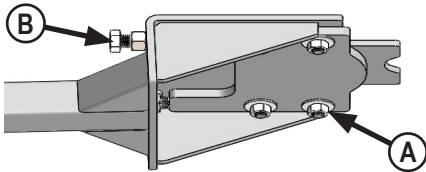

1. Attach push plate to rear of push pole with 4 - 3/4" flat washers and 4 - 3/4" nuts (A). The round edge of push plate towards open end of push pole.
2. Install 2 - 1" x 3" bolts and 2 - 1" nuts at rear of push pole (B). Screw bolts in a few turns. Bolts will be adjusted in a later step.
3. At rear of tractor, pull drawbar out to allow room to install front support.

Installation

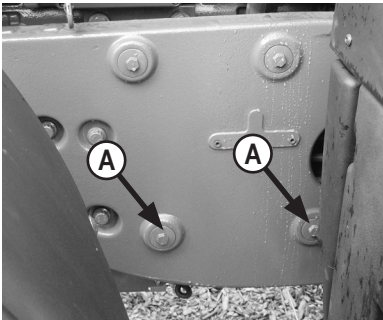

1. **Without** loader brackets, remove bottom 2 plugs from holes on each side of tractor behind front axle (A). Proceed with Step #4.
2. **With** loader brackets, remove bottom 2 bolts from each side of tractor behind front axle (A). Proceed with Step #4.

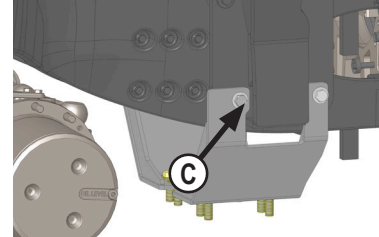

4. Attach side rails to tractor with 4 - 20mm x 130mm bolts and 4 - 3/4" flat washers (C) where plugs or bolts were removed from tractor. **Without** loader brackets, use supplied spacers between side rails and tractor frame.
5. **For 8700 S tractors** - on left side, use a shorter spacer on rear bolt where fuel tank bracket is located.

NOTE: Loosen fuel tank if more room is needed to install rear left bolt.

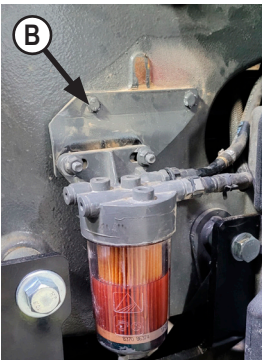

3. **For 8700 S tractors** - Remove fuel filter on left side and flip bracket upside down (B). Reinstall fuel filter.

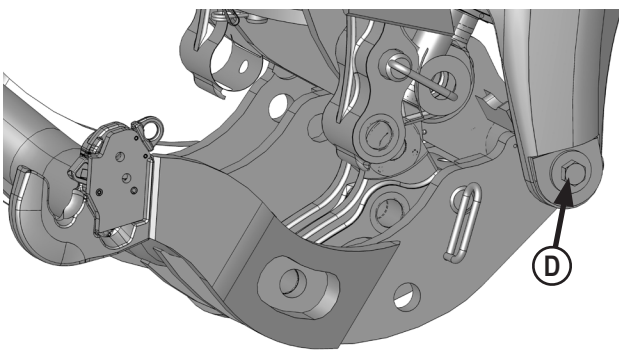

- Support front lifting arms and remove retaining hardware and pins attaching front lifting arms to tractor (D).



Caution: When lifting front and rear support, watch for potential pinching of hoses or other components to prevent any damage.

- Center front support under tractor.

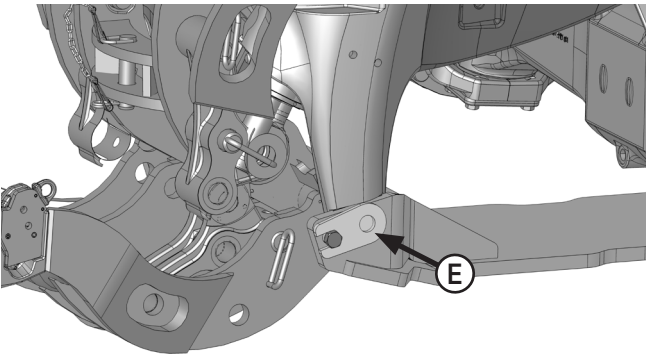

- Raise front support until support ears line up with tractor frame ears and front lifting arms.
- Install new pins and secure pin with spacer, washer and 3/4" x 2-1/2" bolt and 3/4" nut (E).
- Install a 3/4" x 1-1/2" bolt with a 3/4" heavy duty washer at end of pin on right side.

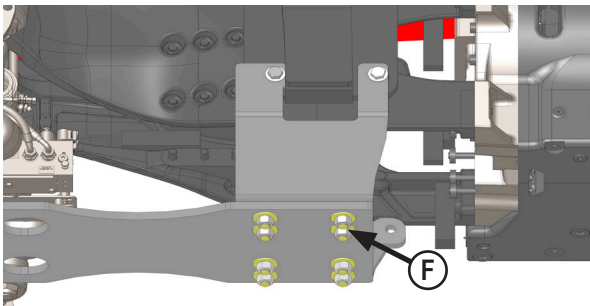

- Attach rear of undercarriage to side rails with 8 - 1" x 3" bolts, 16 - 1" flat washers and 8 - 1" nuts (F).

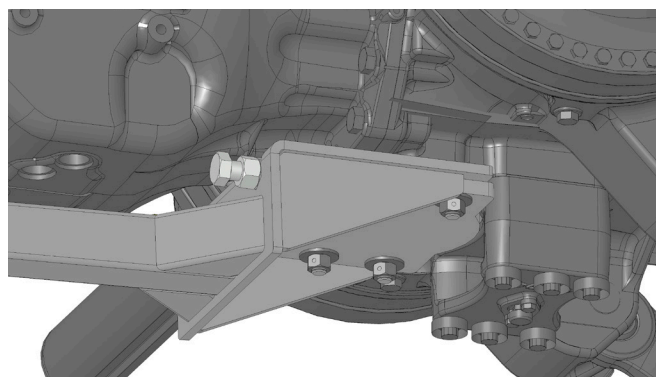

- Raise rear of push pole and rest top plate on top of drawbar bracket.

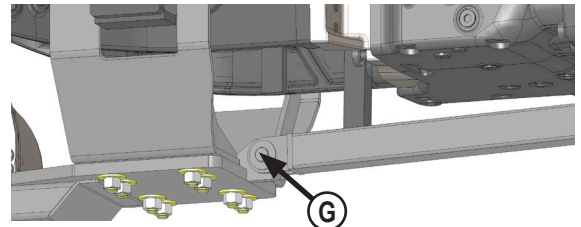

- Attach front of push pole to rear of undercarriage with 1" pin, 2 - 1" washers and a cotter pin (G).
- Torque side rail 20mm bolts (C) to 432 ft-lbs.
- Torque 1" nuts attaching side rails to undercarriage (F) to 909 ft-lbs.

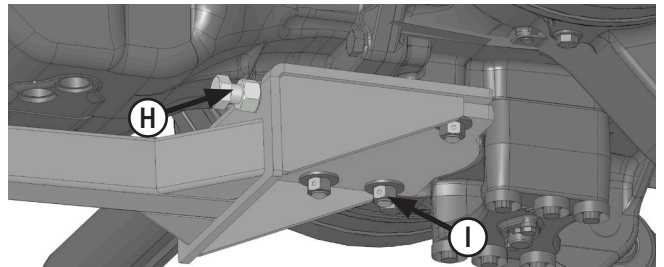

- Evenly unscrew 1" bolts at rear of push pole to push rear plate tight against tractor casting. Torque 1" bolts to 90-95 ft lbs (H).
- Tighten 1" nuts against push pole. The nuts lock bolts in place.
- Torque bottom 3/4" nuts (I) to 257 ft-lbs.
- Reinstall drawbar.
- Check the steering clearance at front support ears.** The minimum clearance between front support pin and tire should be about 1". If necessary, purchase steering stops from your local dealership.

Maintenance

- After first 8 hours of use, re-torque all bolts.
- Check all fasteners regularly to ensure proper operation of equipment.
- Inspect all equipment for existing or potential damages every 10 hours or less.

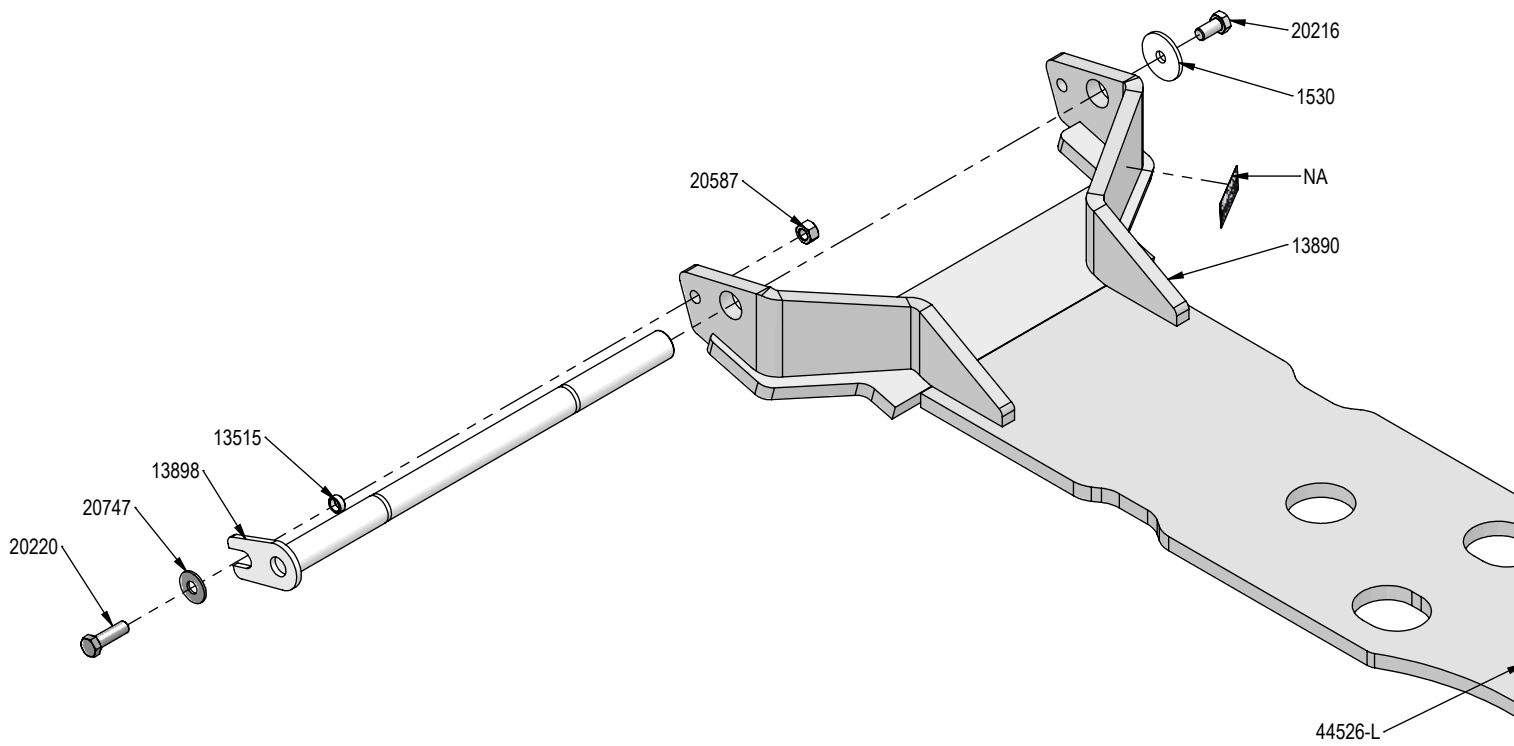

PART NO.	Qty.	DESCRIPTION
1530	1	3/4" x 3".00 x .25" HD Washer CZ
2490	4	20mm x 2.5mm x 130mm Metric Hex Bolt Gr 10.9
13515	1	Spacer, NR Pin
13890	1	Undercarriage Weld
13895	1	Push Pole Weld
13898	1	Pin
13899	4	Spacer
18463	1	1" x 2.75" Pin
18943	1	3/16" x 1-1/2" Cotter Pin
20216	1	3/4" X 1-1/2" Hex Bolt Gr 5 NC CZ
20220	1	3/4" X 2-1/2" Hex Bolt Gr 5 NC CZ
20562	10	1" X 3" Hex Bolt Gr 8 NC YZ
20587	5	3/4" Hex Nut Gr 5 NC CZ
20589	10	1" Hex Nut Gr 5 NC CZ
20747	9	3/4" Flat Washer CZ
20749	2	1" Flat Washer CZ
20819	16	1" Flat Washer Heavy Duty Gr 8 (USS) YZ
44526-L	1	Side Plate Weld
44526-R	1	Side Plate Weld
44529	1	Spacer
NA	1	Serial Number Tag

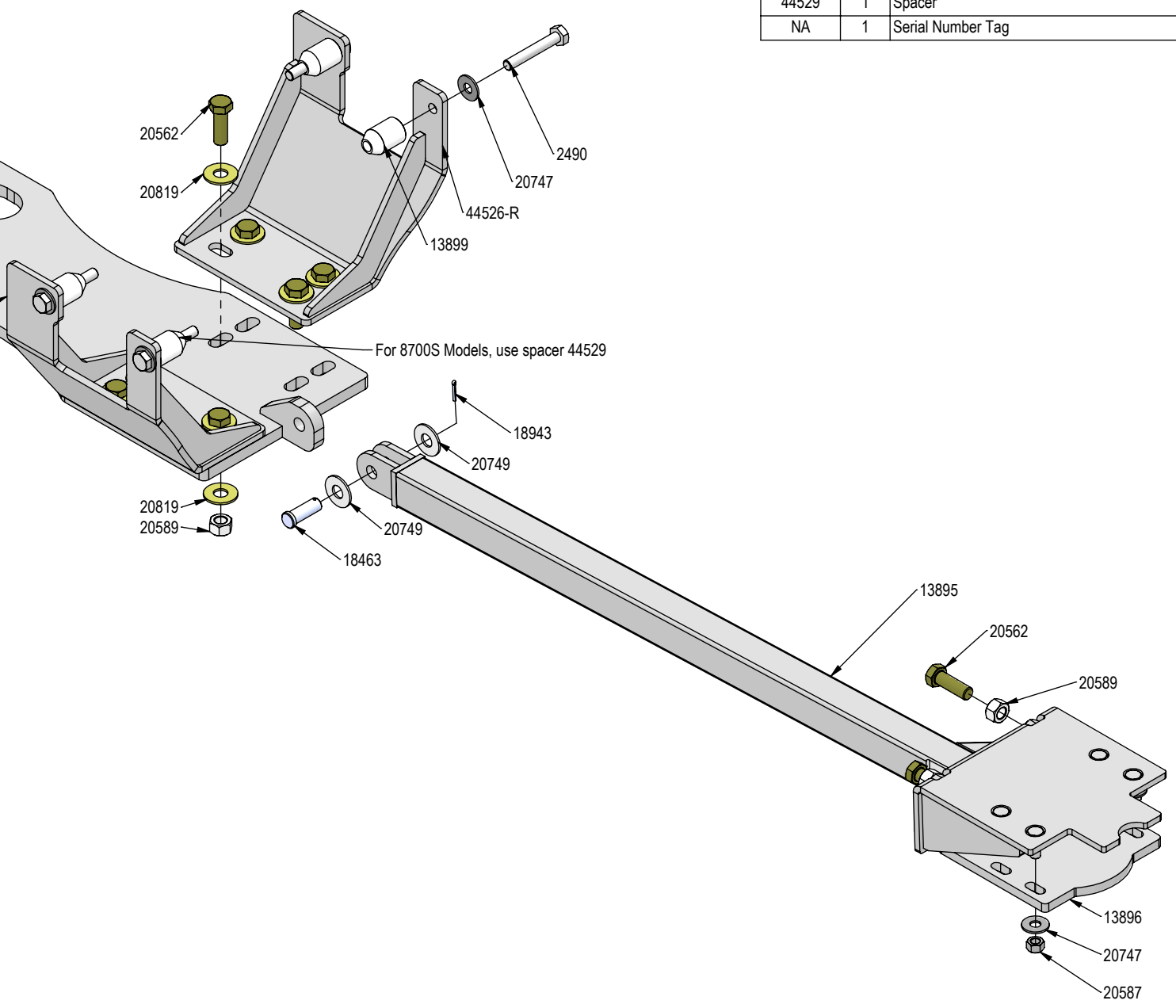

DWG. NO.: 44215-A

PAGE LEFT BLANK INTENTIONALLY

PAGE LEFT BLANK INTENTIONALLY

Improvements

Grouser Products Inc. is continually striving to improve its products. We reserve the right to change prices, specification, or equipment at any time without notice. We also reserve the right to make improvements or changes when it becomes practical and possible to do so without incurring any obligation to make changes or additions to the equipment sold previously.

Warranty

Grouser Products warrants to the original purchaser of each item that the product be free from defects in material and workmanship under normal use and service for a period of **two (2) years for Agriculture Series Blades and one (1) year for Heavy Duty Series from date of original retail delivery.**

The obligation of the consumer under this warranty:

1. To read the operators manual and to operate, lubricate, maintain and store equipment in accordance with the instructions listed in the operators manual.
2. To inspect equipment and if any part needs repair or replacement when continued use would cause damage or wear to other parts or safety.
3. All equipment or parts claimed to be defective in material or workmanship must be made available for inspection at the place of business of a dealer authorized to handle the equipment covered by this warranty, or, upon request by Grouser Products, shipped to the Grouser Products factory in West Fargo, North Dakota.

The obligation of the dealer under this warranty:

1. Complete warranty registration form and submit within 30 days of sale.
2. Contact Grouser Products for authorization prior to performing any warranty repairs or part replacement.
3. Complete warranty request form and submit with photos and supporting documentation.

The obligation of Grouser Products under this warranty:

1. Repair or replace, any equipment or parts, in the judgment of Grouser Products to be defective in material or workmanship.
2. Grouser Products will cover the cost of parts and ground shipping at dealer invoice only.
3. Grouser Products shall have no obligation to bear the cost of labor or transportation in connection with replacement or repair of any such defective parts.

This warranty does not cover:

1. Depreciation or damage caused by normal wear, accident, improper assembly, improper adjustments.
2. Improper maintenance including lack of proper lubrication, or improper use. Including loose bolts, nuts, or fitting due to over tightening or vibration after 20 hours of operation.
3. Repairs or alterations without authorization from a Grouser Products representative.
4. Grouser Products shall have no liability if the equipment has been altered or reworked without the written authorization of Grouser Products.

Grouser Products' parts, which are furnished under this warranty and properly installed, shall be warranted to the same extent as the original parts under this warranty if, and only if, such parts are found to be defective within the original warranty period covering the original equipment.

NO EMPLOYEE OR REPRESENTATIVE OF GROUSER PRODUCTS IS AUTHORIZED TO CHANGE THE WARRANTY IN ANY WAY OR GRANT ANY OTHER WARRANTY.

Contact Us

As always, if you have any questions about your system or other products made by Grouser, feel free to contact us.



755 2nd Ave NW - West Fargo, ND 58078
+1 701-282-7710 | info@grouser.com
www.grouser.com