



Versatile 350-620

Ag Pro Undercarriage

Installation Instructions

For Models:

Versatile: 350, 375, 380, 400, 405, 430, 450, 460, 500, 520, 530, 550, 570, 575, 580, 610, 620

Model Year 2012-Current

Purchase Date
Serial Number
Model Number
Tractor Model
Dealer

To The Owner

This manual contains information concerning the installation of the undercarriage. You have purchased dependable, long lasting equipment, but only by proper care and operation can you expect to receive the performance and long service built into our products. Please have all operators read this manual carefully and keep the manual available for ready reference. If you have any questions or concerns, contact Grouser Products.

Caution:

- Always use caution when working around any equipment.
- Always wear safety glasses.
- Follow tractor manufacturer's safety guidelines when installing this product.
- Use paint where necessary to prevent rust.
- Do not modify or permit anyone else to modify or alter the equipment and its components without first consulting Grouser Products.
- Operate within your own capabilities. Recommended operating speed is 3-5 MPH (5-8 km/h).

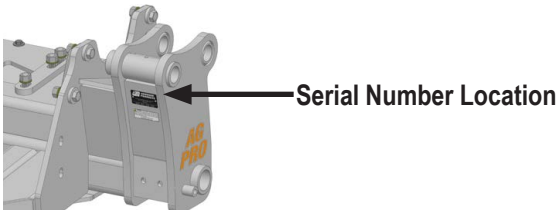

Note:

- Read all instructions prior to performing installation.
- When installing hardware, only finger tighten until all hardware is in place.
- A full diagram of the assembly with the full list of parts is on pages 6-7.
- Tractor frame not shown in some diagrams for clarity.
- Unstrap and remove any components that are attached for shipping.

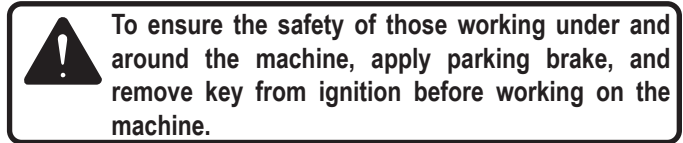

Installation

1. Remove existing toolboxes, front weights, and tow cable holder if equipped. Tow cable holder can be reinstalled later with undercarriage.
2. Remove front cover on undercarriage if necessary.
3. For tractor models 450 and 500-620, continue with Step #5.
4. For tractor models 350-430 and 460, continue with Step #7.

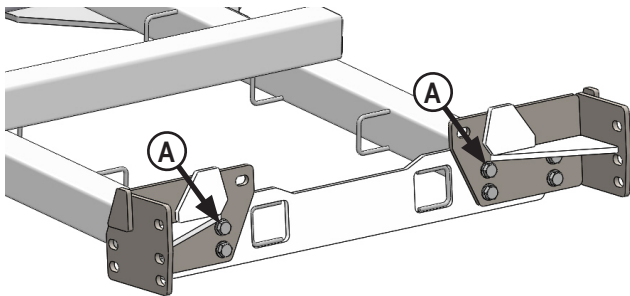

5. Attach rear brackets to rear of undercarriage with 8 - 3/4" x 2" bolts, 16 - 3/4" washers, and 8 - 3/4" nuts (A).

NOTE: The left bracket (long plate against undercarriage) attaches on left side of undercarriage and right bracket on right side.

6. Continue with Step #8.

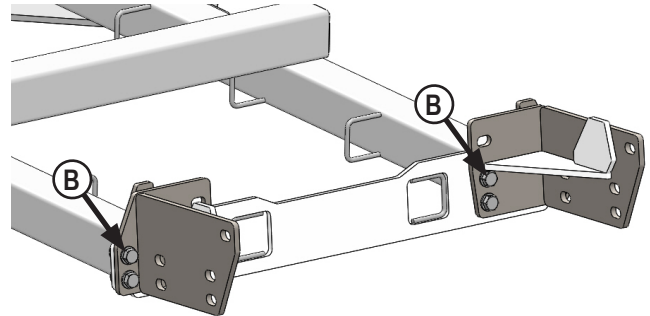

7. Attach rear brackets to rear of undercarriage with 8 - 3/4" x 2" bolts, 16 - 3/4" washers, and 8 - 3/4" nuts (B).

NOTE: The right bracket (short plate against undercarriage) attaches on left side of undercarriage and left bracket on right side.

8. Position undercarriage under tractor and center on tractor frame.

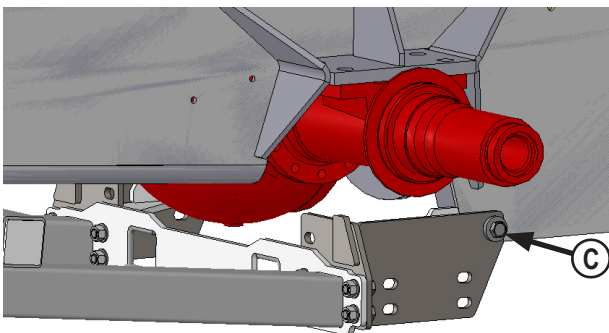

NOTE: When lifting undercarriage, watch for any potential pinching of hoses or any other components to prevent any damage.

- Raise rear of undercarriage and attach rear brackets to frame of tractor behind front axle with 2 - 20mm x 70mm bolts, 4 - 3/4" ID thick washers and 2 - 20mm nuts (C).

NOTE: The above photo shows the brackets installed on a narrow frame but the installation is the same for the wide frame.

- Raise front of undercarriage until holes line up with holes on tractor.

NOTE: Add shims between undercarriage and tractor frame to reduce any gap if necessary. Use shims until there is a gap of 1/16" or less on front. See attached diagram for proper location and orientation of each shim. Do Not put all shims on one side of undercarriage.

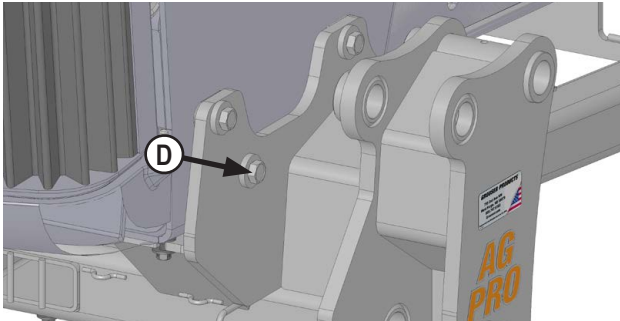

- Install 8 - 20mm x 70mm bolts, 8 - 3/4" ID thick washers, 8 - 3/4" washers and 8 - 20mm nuts into side holes of undercarriage, shims if necessary, and tractor frame (D).

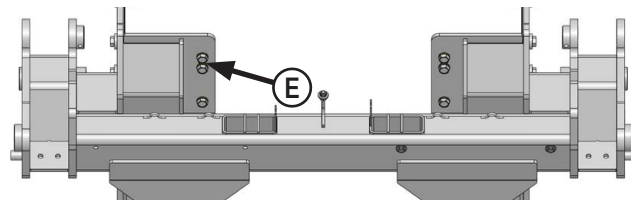

NOTE: If tow cable bracket was equipped, reinstall bracket when installing front 6 vertical bolts. See Page 5 for more hardware and installation information.

- At front of undercarriage, install 6 - 20mm x 70mm bolts, 12 - 3/4" washers and 6 - 20mm nuts into front vertical holes of undercarriage and tractor frame (E). The bolt has to be inserted from bottom.
- Push undercarriage back until rear brackets are pushing against tractor frame.
- Torque rear 20mm bolts to 432 ft-lbs (C).
- Torque 3/4" bolts to 257 ft-lbs (A&B).
- Torque front 20mm bolts to 432 ft-lbs (E).
- Torque side 20mm bolts to 432 ft-lbs (D).
- If the front cover was removed, reattach with the original hardware.

NOTE: Installer is responsible to route hoses in a practical manner. The hoses need to be routed away from sharp and moving objects and need to be secure. Install all hoses when assembling the lift system in the Owner's Manual and Parts Book. Refer to Page 4 for some hose routing pictures.

Assembling Lift Components

- Refer to the Blade Owner's Manual & Parts Book for instructions on how to assemble the lift components.

Hose Routing

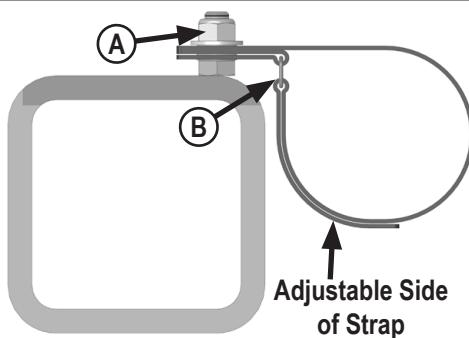

- Attach a velcro hose strap on every bolt along undercarriage with a 3/8" flange nyloc nut (A). Assemble strap with the metal loop on bottom side as shown (B). Keep straps open.

NOTE: Orientation of velcro strap is important and is shown in photo.

NOTE: Quantity of hoses is dependent on which blade system is being used.

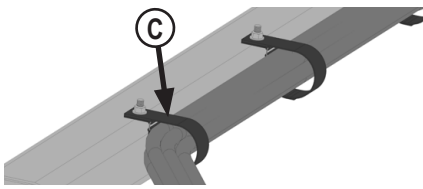

- Route hoses along undercarriage tubes and secure with velcro straps (C).

NOTE: While grouping hoses together, do not cross hoses over each.

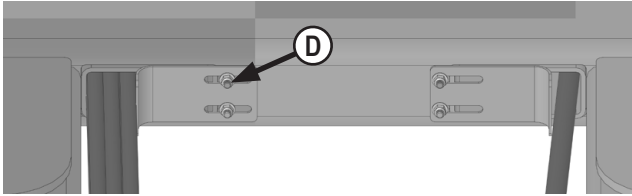

- Attach hose cover plates to undercarriage with 4 - 3/8" flange nyloc nuts (D). Slide plates until snug against hoses and tighten nuts.

NOTE: While grouping hoses together, do not cross hoses over each.



- After routing the hoses through the undercarriage, route in the same location as the tractor's hoses (E). Replace zip ties if you run the hoses in the tractor's original hose cordura.

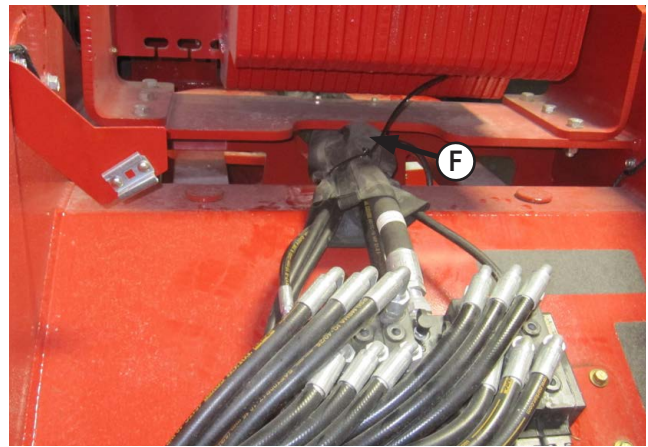

- Exit the rear frame at the center of the frame as shown in the picture (F).
- Use zip ties to attach hoses, where necessary, to avoid rubbing and pinch areas.

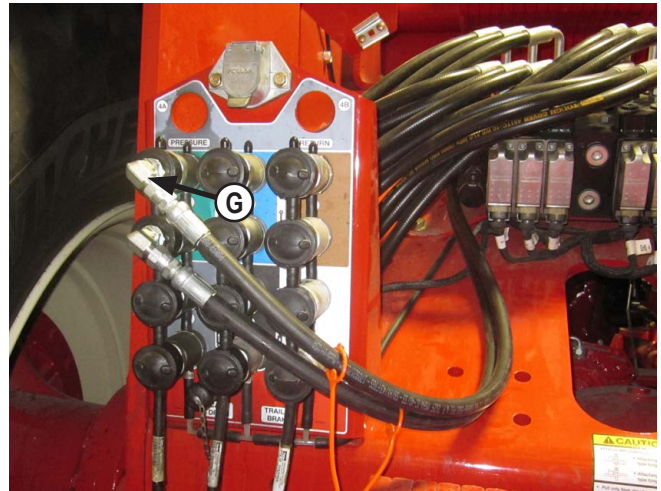

- After installing the male couplers, plug each set into a set of rear SCV's (G).
- Perform an articulation check to make sure hoses do not get pulled when fully articulated. Make adjustments and allow adequate slack if necessary.

Maintenance

- After first 8 hours of use, re-torque all bolts.
- Check all fasteners regularly to ensure proper operation of equipment.
- Inspect all equipment for existing or potential damages every 10 hours or less.
- Inspect hoses at articulation point and around lift system. Check for any abrasion or damage to hoses.

Tow Cable Installations

NOTE: Your undercarriage may vary slightly from one shown in pictures below, but same installation procedure will be compatible.

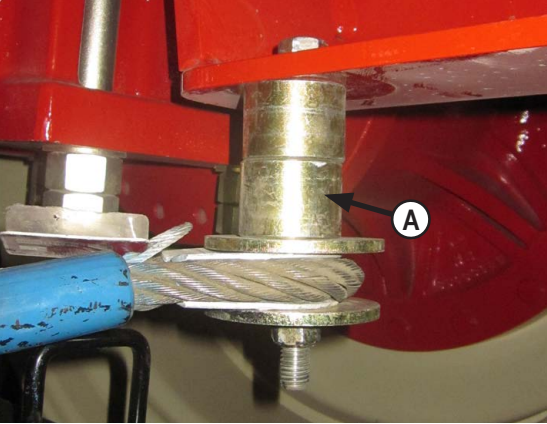

1. Add 2 spacers in between cable holder and tractor frame by front tires. Use a 5/8" x 6" bolt (PN: 16-20200), 2 - 5/8" washers (PN: 57-20746) and a 5/8" top lock nut (PN: 70-20646) on each side (A).

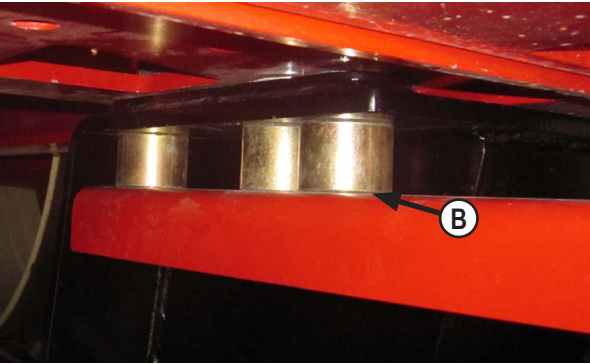

2. Install front cable support bracket at front of undercarriage. Install with 3 spacers on each side in between undercarriage and bracket. Use 3 - 20mm x 120mm (PN: 16-2489) to install bracket and undercarriage. Use same washers and nuts that were used in mounting instructions on Page 3 (B).

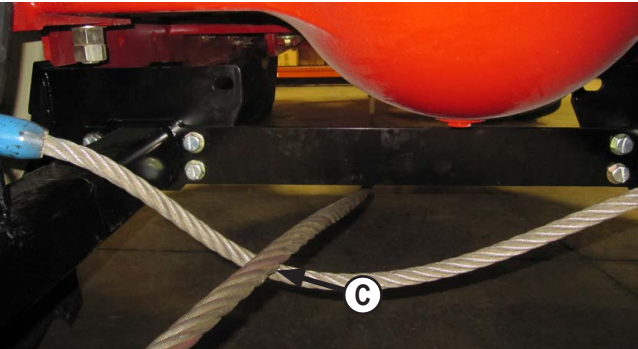

3. Route cable underneath undercarriage, then over cable support and under undercarriage on right side (C).



4. Install original bracket to side of undercarriage with 2 - 3/4" x 2" bolts (PN: 16-20218) and 2 - 3/4" nuts (PN: 70-20607) (D). Cable clamp is installed in Step #6.



5. Finish routing cable under the lift frame and up over the cable bracket. Attach to bracket with original hardware (E).
6. Pull cable so there is some slack at front under lift frame as shown in the picture above. Then put a cable clamp by side bracket as shown in picture from Step #4 to keep the cable in place.

Note: Narrow frame uses the left rear bracket on the right side of the undercarriage and the right bracket on the left side of the undercarriage as shown in the diagram below.

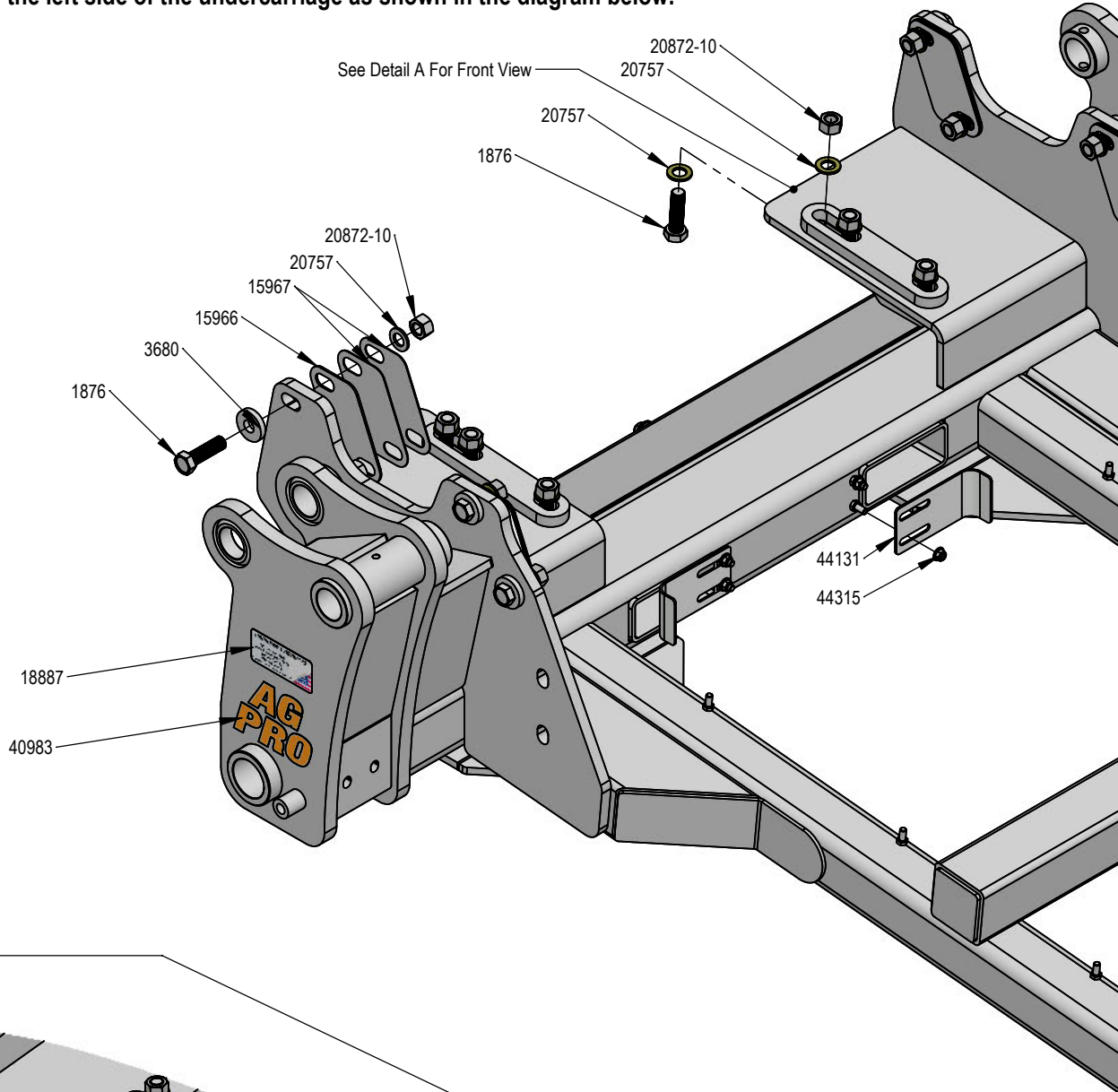

DETAIL A

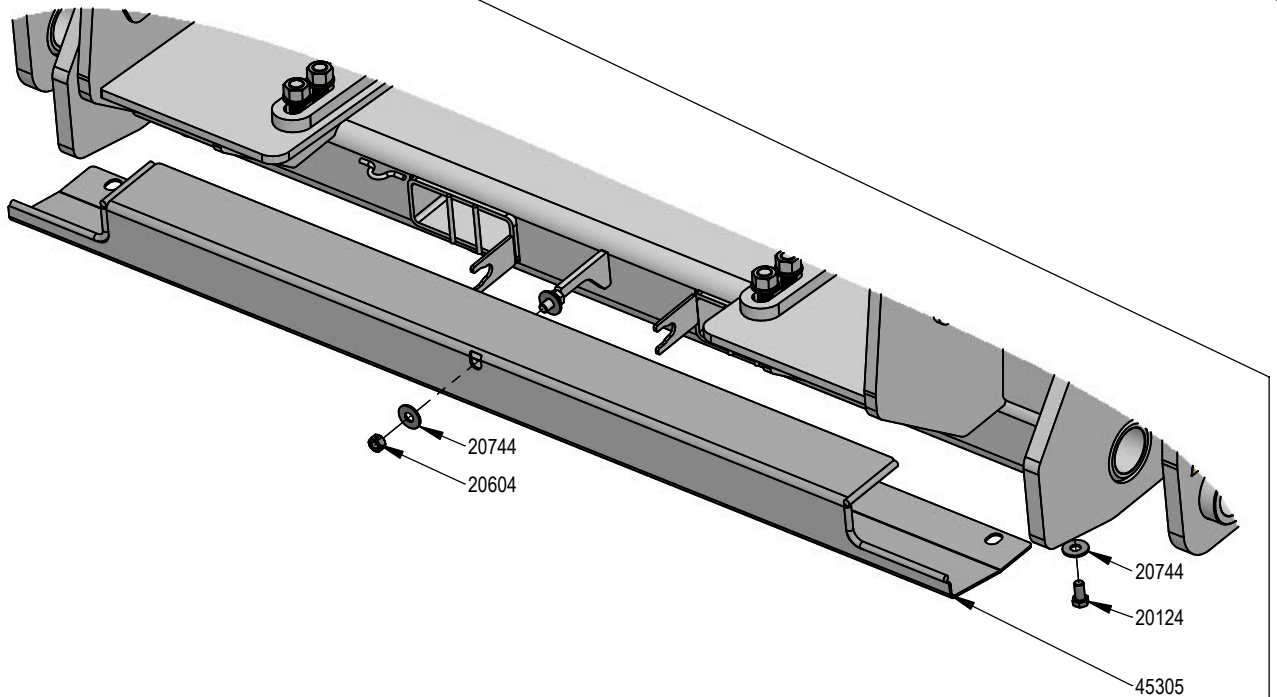

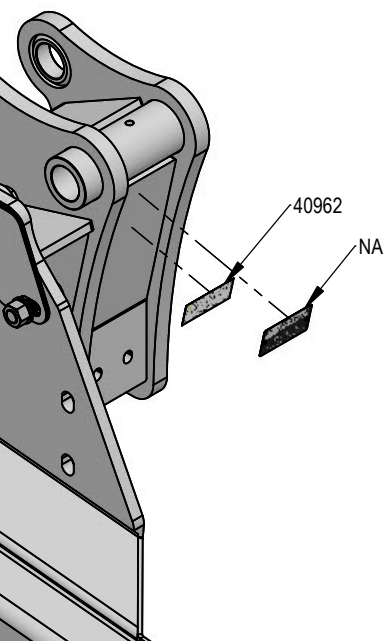

Qty.	PART NO.	DESCRIPTION
16	1876	20mm x 2.5mm x 70mm Hex Bolt Gr 10.9
4	20124	1/2" X 1" Hex Bolt Gr 5 NC CZ
8	20218	3/4" X 2" Hex Bolt Gr 5 NC CZ
12	3680	0.75" ID x 2.00" OD x .375" Heavy Washer
5	20744	1/2" Flat Washer CZ
36	20757	3/4" SAE Hardened Flat Washer - 1-1/2" OD
1	20604	1/2" Hex Center Lock Nut Gr 5 NC CZ
8	20607	3/4" Hex Center Lock Nut Gr 5 NC CZ
16	20872-10	M20-2.5 Class 10.9 Hex Nut CZ
1	15945-L	Adapter Bracket
1	15945-R	Adapter Bracket
4	15966	Versatile T4 Shim Plate (.125")
8	15967	Versatile T4 Shim Plate (.06")
1	18887	Grouser Name Plate Decal - Made in USA
1	40962	Warning Prop 65 Decal
2	40983	Ag Pro
2	44131	Plate, Hose Cover
1	44220	Undercarriage Weld, Ag Pro Plus
4	44315	3/8" Nyloc Flange Nut Gr N5 NC
1	45305	Front Hose Cover
1	NA	Serial Number Tag

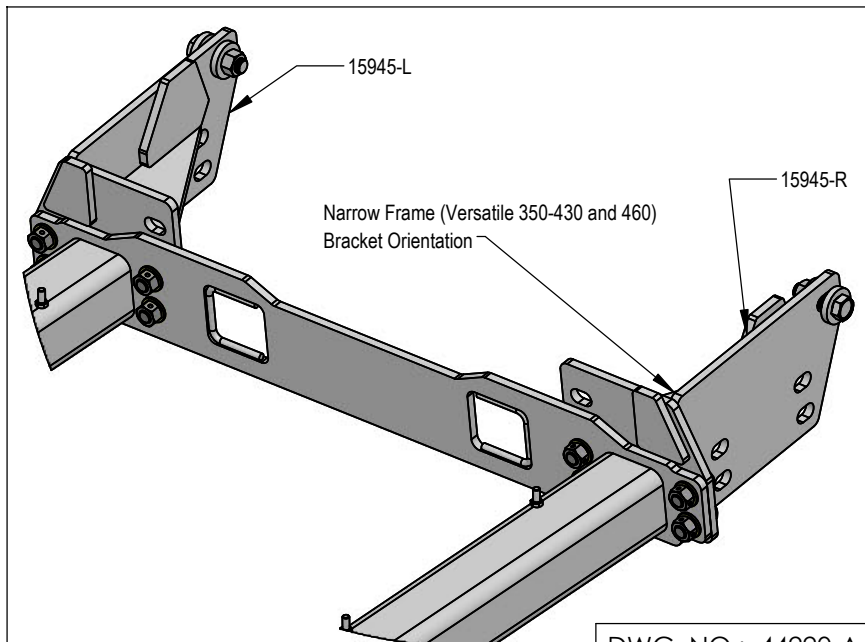
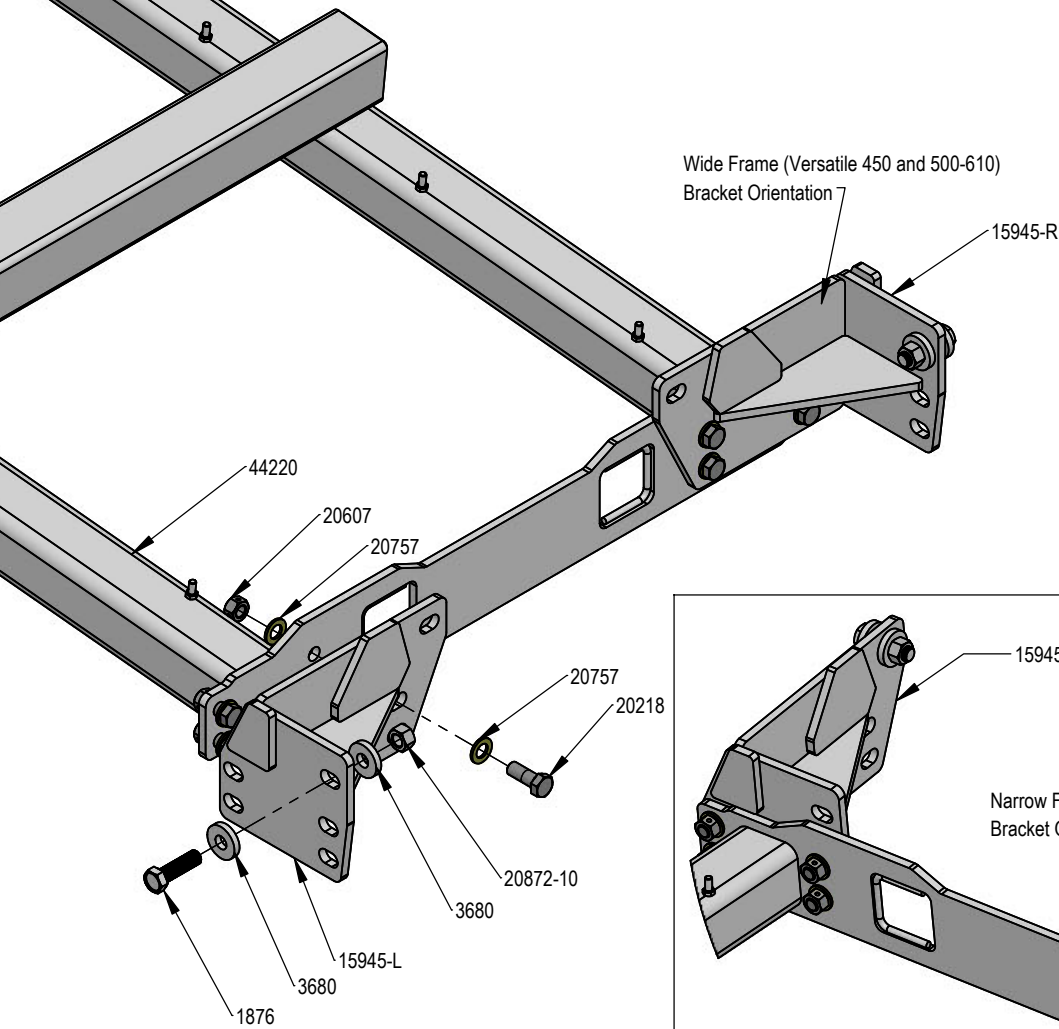

DWG. NO.: 44220-A

Improvements

Grouser Products Inc. is continually striving to improve its products. We reserve the right to change prices, specification, or equipment at any time without notice. We also reserve the right to make improvements or changes when it becomes practical and possible to do so without incurring any obligation to make changes or additions to the equipment sold previously.

Warranty

Grouser Products warrants to the original purchaser of each item that the product be free from defects in material and workmanship under normal use and service for a period of **two (2) years for Agriculture Series Blades and one (1) year for Heavy Duty Series from date of original retail delivery.**

The obligation of the consumer under this warranty:

1. To read the operators manual and to operate, lubricate, maintain and store equipment in accordance with the instructions listed in the operators manual.
2. To inspect equipment and if any part needs repair or replacement when continued use would cause damage or wear to other parts or safety.
3. All equipment or parts claimed to be defective in material or workmanship must be made available for inspection at the place of business of a dealer authorized to handle the equipment covered by this warranty, or, upon request by Grouser Products, shipped to the Grouser Products factory in West Fargo, North Dakota.

The obligation of the dealer under this warranty:

1. Complete warranty registration form and submit within 30 days of sale.
2. Contact Grouser Products for authorization prior to performing any warranty repairs or part replacement.
3. Complete warranty request form and submit with photos and supporting documentation.

The obligation of Grouser Products under this warranty:

1. Repair or replace, any equipment or parts, in the judgment of Grouser Products to be defective in material or workmanship.
2. Grouser Products will cover the cost of parts and ground shipping at dealer invoice only.
3. Grouser Products shall have no obligation to bear the cost of labor or transportation in connection with replacement or repair of any such defective parts.

This warranty does not cover:

1. Depreciation or damage caused by normal wear, accident, improper assembly, improper adjustments.
2. Improper maintenance including lack of proper lubrication, or improper use. Including loose bolts, nuts, or fitting due to over tightening or vibration after 20 hours of operation.
3. Repairs or alterations without authorization from a Grouser Products representative.
4. Grouser Products shall have no liability if the equipment has been altered or reworked without the written authorization of Grouser Products.

Grouser Products' parts, which are furnished under this warranty and properly installed, shall be warranted to the same extent as the original parts under this warranty if, and only if, such parts are found to be defective within the original warranty period covering the original equipment.

NO EMPLOYEE OR REPRESENTATIVE OF GROUSER PRODUCTS IS AUTHORIZED TO CHANGE THE WARRANTY IN ANY WAY OR GRANT ANY OTHER WARRANTY.

Contact Us

As always, if you have any questions about your system or other products made by Grouser, feel free to contact us.



755 2nd Ave NW - West Fargo, ND 58078
+1 701-282-7710 | info@grouser.com
www.grouser.com